

# Bobbie VII Operation Instructions

## Frame Number and Engine Number

Please record the motorcycle numbers as indicated below and store the spare key in a safe place. Only the existing key can be used for creating a duplicate key. In case both keys are lost, it is needed to replace the whole set of locksets.

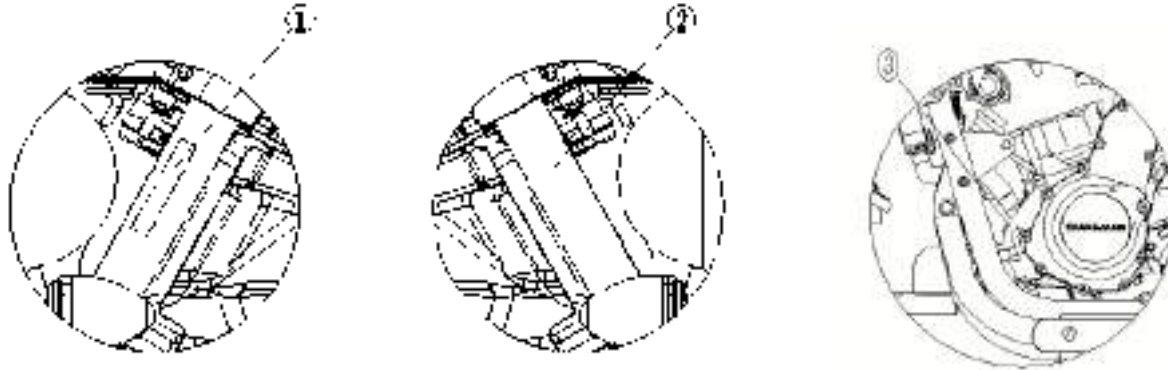

- ① Vehicle nameplate: \_\_\_\_\_
- ② Frame No.: \_\_\_\_\_
- ③ Engine No.: \_\_\_\_\_

## Parameters

### Performance

Item	Parameter	Item	Parameter
Maximum power (kW)/corresponding rotation speed (r/min)	55/8500	Maximum torque (N·m)/corresponding rotation speed (r/min)	68/6500

### Size

Item	Parameter	Item	Parameter
Length (mm)× Width (mm)× Height (mm)	2247×927×1126	Wheelbase (mm)	1520
Seat height (mm)	780	Ground clearance (mm)	130
Complete vehicle curb weight (KG)	210		

### Engine

Item	Parameter	Item	Parameter
Type	Double-cylinder, four-stroke, water-cooling,	Displacement (mL)	693

	paralleling upright		
Cylinder diameter (mm) × stroke (mm)	83×64	Compression ratio	11.6 : 1
Starting system	Electrical starting	Ignition order	From left to right, 1-2
Fuel mixing system	Electronic fuel injection system	Ignition system	Electronically-controlled inductance discharge ignition
Ignition advance Angle (before top dead center compression position)	10BTDC@1450r/min	Electron ignition advance angle	33BTDC@6000r/min
Sparking plug	CR8EI	Lubrication system	Pressure splash lubrication (semi-dry oil sump)
Oil type	ELF Company 10W-40/SJ Level JASO MA2 certified oil	Oil volume (L)	2.6
Coolant volume (mL)	900		

### Transmission

Item	Parameter	Item	Parameter
------	-----------	------	-----------

Gearshift method	Sixth gear international standard gear		Clutch type	Wet multi-pad, manual clutch
Driving system	Chain drive		Primary reduction ratio	2.095
Gear ratio of first gear	2.353		Gear ratio of second gear	1.714
Gear ratio of third gear	1.333		Gear ratio of fourth gear	1.111
Gear ratio of fifth gear	0.966		Gear ratio of sixth gear	0.852

### Chassis

Item	Parameter		Item	Parameter
Top rake (°)	29		Tire/rim specifications (front)	120/80-17/17×2.75
Tire/rim specifications (rear)	150/80-16/16×3.5			

### Fuel tank volume:

Item	Parameter		Item	Parameter
Main fuel tank (L)	15			

## Electrical installation

Item	Parameter	Item	Parameter
Battery	12V11.2Ah	Light type	LED
Nominal power of headlamp (W)	35		

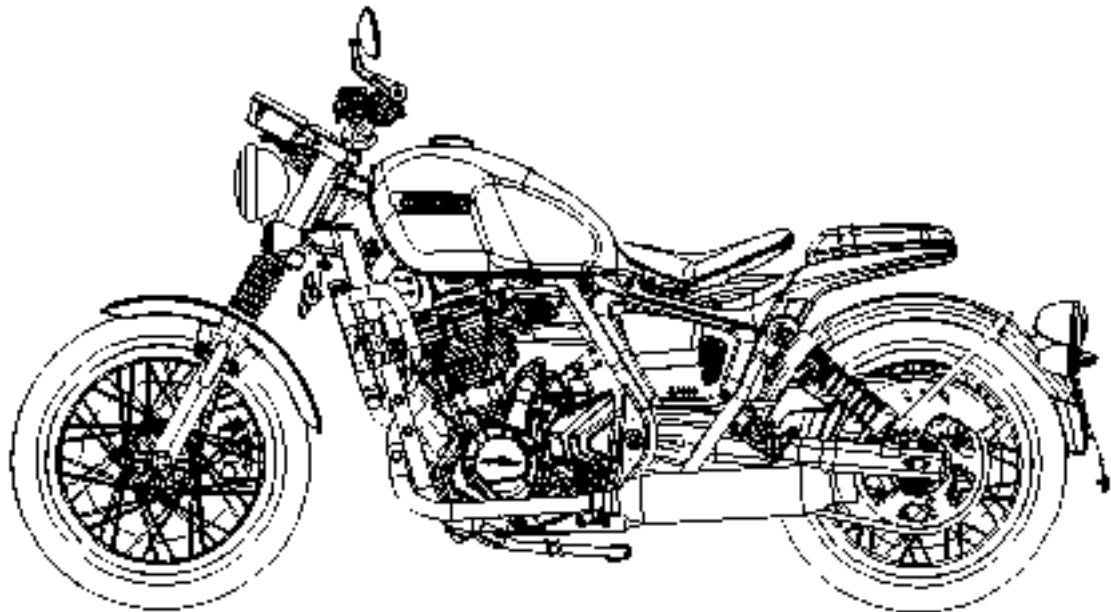

## Instrument combination:

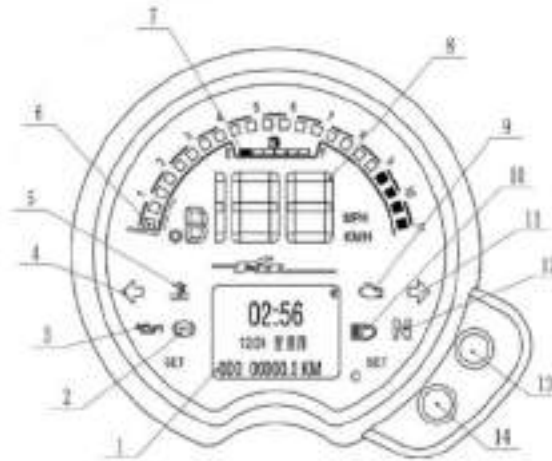

1. Total mileage/subtotal mileage
2. ABS alarm lamp
3. Oil alarm lamp
4. Left turn indicator lamp
5. Water temperature alarm lamp
6. Engine tachometer
7. Fuel display
8. Speed display
9. Fault indicator lamp
10. High beam indicator lamp
11. Right turn indicator lamp
12. Neutral lamp
13. Key S1
14. Key S2

### **Total mileage/subtotal mileage 1**

It is needed to short press S2 to perform the switching of the total mileage and subtotal mileage.

### **ABS alarm lamp 2**

In case of a fault of the ABS system, the ABS alarm lamp will lighten.

In case the ABS alarm lamp lightens, please contact your dealer for inspection and maintenance.

### **Oil alarm indicator lamp 3**

When the key switch is turned on but the engine is not started, the oil alarm lamp always lightens. After the engine is started, the oil alarm lamp should go out. In case the alarm lamp lights, it indicates that the oil quantity is lower than the requirements and it is necessary to add oil promptly.

### **Left turn indicator lamp 4**

When the left turn switch “” on the left handlebar switch is pressed, the left turn indicator lamp will lighten. When the left turn switch is pressed again, the indicator lamp will go out.

### **Water temperature warning lamp 5**

When the water temperature of the engine exceeds 110°, the water temperature alarm lamp will lighten.

### **Engine tachometer 6**

The engine tachometer shows the current engine rotation speed (r/min). There is a “red area” on the right side of the tachometer. The pointer of the tachometer in the red area indicates that the engine rotation speed is beyond our recommended engine rotation speed and is also out of its optimum operating range.



When the ignition switch is turned to “” position, the tachometer pointer and LCD of the instrument will conduct a self-test promptly. In case the tachometer pointer is provided with an incorrect indication or the LCD of the instrument indicating the occurrence of the fault, please contact your dealer for inspection and maintenance.

### **Fuel indication 7**

Display the fuel volume in the fuel tank. When the full display of 5 grids of fuel volume indicates that the fuel tank is full. When there is only one grid left and the oil level starts to flash, it indicates that the fuel tank is insufficient (less than 3L). It is necessary to add fuel promptly. When the fuel symbol “”, E and F are not displayed, it indicates that the plug of the oil level sensor is not plugged in or damaged.

When the “” symbol flashes, it is needed to add fuel promptly. Otherwise, the fuel pump will be damaged.

### **Speed display 8**

Display the current driving speed. When the driving speed shows  $\geq$  “109”, it means that your current speed has exceeded the designed maximum speed of the vehicle and it is needed to reduce the speed promptly.

### **Fault indicator lamp 9**

When the ignition switch is turned to the “” position, the fault lamp always lightens when the engine is not started. It will go out after the engine is started. This is a normal phenomenon and no maintenance is required. In other cases, the fault lamp lightens, which indicates that there is a fault in the vehicle circuit.

When “” lightens abnormally, please contact your dealer for inspection and maintenance

## High beam indicator lamp 10

When the right handlebar switch is turned to the “” position and the dimmer switch is turned to the “” position, the high beam indicator lamp will lighten.

## Right turn indicator lamp 11

When the right turn switch “” on the right handlebar switch is pressed, the right turn indicator lamp will lighten. When the right turn switch is pressed again, the indicator lamp will go out.

## Neutral indicator lamp 12

When the engine is in neutral, the neutral indicator lamp will lighten.

## Key S1

1. It is needed to short press S1 in the normal interface to perform the switching of the metric system and British system.
2. In case of pressing S1 for over 3 seconds in the normal interface, the subtotal mileage will be reset.
3. Press S1 to turn on the ignition key (power on) and enter the password input interface. Then, release S1 and short press S1 for the corresponding digit changes from 0 to 9. Later, long press S1 for more than 3 seconds to move to the next digit while the next digit flashes. After inputting the password, press S1 for more than 3 seconds to enter the parameter setting interface. Adjust the corresponding parameters in the same way. After the parameters are adjusted, it is needed to long press S1 for more than 3 seconds to enter the normal interface of the instrument. The parameter is adjusted successfully at this time.

## Key S2

1. It is needed to short press S2 in the normal interface to perform the switching of the subtotal / total mileage.

Turn off the main power
Turn on the main power
Lock the direction

## Description of interconnect mode between meter and mobile phone

Mobile phone interconnect mode, can achieve car search, mobile phone on-screen navigation, listening to music and call tips and other functions. Here' s how to connect your phone:

- 1、 Download the “Motofun” APP from the mobile APP market, Click on all the options, install it and get into the APP to work;
- 2、 Once in the APP, Click the Bluetooth connection shown in figure 2;
- 3、 When the Bluetooth is not open, you will be prompted to ask the Bluetooth to open. Choose “Allow” to open the Bluetooth;
- 4、 As the phone approaches the meter, click on “FSC-BT966C-LE” in the Bluetooth signal to connect, as shown in figure 3 and figure 4;



Figure 2



Figure 3



Figure 4

- 5、Click on the Bluetooth Connection icon to enter the Bluetooth settings screen, as shown in figure 5, Select “FSC-BT966C” audio Bluetooth connection, after connecting as shown in figure 6 click settings;
- 6、Open all settings in the settings screen as shown in the following figure;
- 7、Go back to the MOTOFUN APP’ s main screen, Click find the car, enter your phone number and Verification Code in the subsequent login screen, Click login and a map containing the location of the car will pop up, click navigation, music, etc. , the instrument then enters the corresponding interface, at this time if there is a phone call in the instrument will show below the calling number。



Figure 5



Figure 6







Figure 7

## key set

It is important to use the key to turn on the ignition switch / directional lock and fuel tank cover. So, you must keep the key well and store the spare key in a safe place so that the key can be duplicated in case of loss. Otherwise, you can only replace the whole set of locksets.

### Ignition switch / directional lock

The ignition switch is equipped with “”, “”, “” and other positions.

-  : The engine can operate and all circuits of the vehicle are connected.
-  : The engine cannot operate and all circuits of the vehicle are disconnected.
-  : The direction handle is locked and all circuits of the vehicle are disconnected to prevent vehicle theft.

## Right handlebar switch



1 Starting button 2 Lighting switch 3 Right turn switch

## Starting button 1

When the key is in the “” position and the gear is in the neutral gear, it is feasible to directly press the starting button to start the engine. When the gear is in other gears, it is needed to hold the clutch switch and press this button at the same time to start the engine.

## Lighting switch 2

Lighting switch includes “”, “” and other positions.

 : When it is set in this position, the headlamp, position lamp, license plate lamp and instrument backlight can be lightened.

 : When it is set in this position, the headlamp, position lamp, license plate lamp and instrument lamp are turned off.



## Right turn lamp switch 3



In case of pressing “”, the right turn lamp and the right turn indicator lamp on the instrument flash and lighten. In case of pressing it again, the above lamps go out.

## Left handlebar switch

### Dimmer switch 1

The dimmer switch includes “” “” and other positions.

 : When it is set in this position and the lighting switch is set to “” position, the high beam lamp of the headlamp and the high beam indicator lamp on the instrument lighten.

: When it is set in this position and the lighting switch is set to the “” position, the low beam lamp of the headlamp lightens.

### **Left turn lamp switch 2**



In case of pressing “”, the left turn lamp and the left turn indicator lamp on the instrument flash and lighten.

1 Dimmer switch
2. Left turn lamp switch
3. Horn button

### **Horn button 3**

In case of pressing the ‘’ button and the horn will make a sound.

### **Warning function**

In the event of an accident or other emergency, it is needed to press the left handlebar “” and the right handlebar “” switch at the same time and all steering lamps will flash, which plays the roles of prompting, warning and caution. It is important to press the left and right turn switches at the same time to turn off the turn lamp.

Left heating handlebar sleeve
Heating indicator lamp
Heating control switch

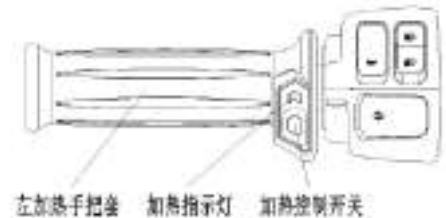



## **Heating handle sleeve**

The heating handle sleeve can only be turned on after the engine is started. When the power is on, the indicator lamp on the left heating handle sleeve will turn green and flash three times, indicating that the function is normal. In case the color is blue, it indicates that the protection function does not operate, but it can perform the normal heating. At this time, it is needed to implement the maintenance and replacement promptly. In standby status, in terms of pressing the button on the handle sleeve, in case the power supply voltage is lower than 12.9V, the red indicator lamp will flash several times to enter the standby status. In case the power supply voltage is higher than 12.9V at this time, the system will enter into rapid heating. Each time the button is pressed, the electric heating power will increase by 20%. There are 5 gears in total and the colors of the indicator lamp are blue- cyan-green-purple-red.

In the operation status, the power supply voltage is lower than the electric heating starting voltage and the corresponding gear indicator lamp flashes. At this time, in case the voltage is lower than this voltage for 7 seconds, the controller will cut off the electric heating output and enter the standby status. In case the normal voltage is restored within 7 seconds, the indicator lamp will always lighten and enter into normal operation.

## Parking brake handle



When the handle is in position 1, the vehicle is in non-parking brake status.

When the handle is in position 2, the vehicle is in the parking brake status.

## ECU (electronic control unit) 1

**ECU:** It is the abbreviation of the electronic control unit. It is actually an integrated circuit board. The manufacturer has set a reasonable control program and data for ECU. The fuel injection of the injector and the ignition of the high-pressure coil are both controlled by detecting the signals from all sensors so that the engine can obtain the best fuel injection volume, injection time and ignition time under various operating conditions. Later, the requirements of output torque, low fuel consumption and emission warranty can be met. Meanwhile, ECU also has the function of system fault diagnosis. In case of a fault in a link or an incredible signal value, ECU will set fault information record in RAM fault memory promptly. The fault information record is stored in the form of fault code and displayed in the order of fault occurrence. The fault can be divided into “current fault” and “historical fault”.

During maintenance, the fault components can be quickly found through the diagnostic instrument and fault indicator lamp, which improves maintenance efficiency and quality.

### **Diagnostic interface 2**

Pull out the plastic cover of the diagnosis interface and connect the interface of the diagnostic instrument and diagnosis interface.

Judge the cause of the fault in accordance with the fault code of the diagnostic instrument (See the comparison table of fault code of the electronic fuel injection system for details) and implement the maintenance.

### **Fuse box 4**

In case the fuse is blown, it is needed to check whether there is a fault in the electrical system and replace it with a new fuse with the same ampere after repairing the fault. It is forbidden to connect the corresponding wire directly over the fuse. Similarly, it is forbidden to use other wires to replace the corresponding fuse.

### **Fuel tank**

When the fuel tank is filled with fuel, the fuel level shall not exceed the bottom surface of the fuel cup at the fuel filler

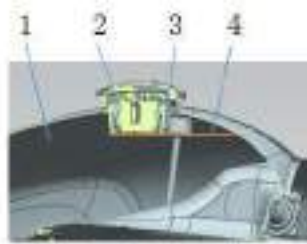

1. 油箱 2. 油箱盖 3. 加油口  
4. 最高燃油水平

1. Fuel tank
2. Fuel tank cover
3. Fuel filler
4. Maximum fuel level

## Adjustment of rearview mirror

It is needed to loosen the hexagon bolt in the inner hole of the end face of the direction handle and rotate the rearview mirror to adjust the viewing angle. After adjustment, it is important to tighten the hexagon bolt. The adjustment methods of left and right rearview mirrors are the same.

## Side stand

The flameout switch is installed on the side stand. When the side stand supports the car body, it is forbidden to start the engine in gear.

## Running-in

The running-in period of the vehicle is the first time to drive 1500km. Regular maintenance shall be implemented according to the provisions of the running-in period. During the running-in period, the following provisions must be followed:

- The recommended maximum engine rotation speeds during the running-in period are as follows:

Total vehicle mileage	Maximum engine rotation speed
0km~800km	4000r/min
0km-800km	
800km~1500km	6000r/min
800km-1500km	



- It is forbidden to press the starting button while driving and operate the engine at high speed promptly at the beginning of starting. Even after the engine is heated, it should run at idle speed for 2-3 minutes to let the lubricating oil enter all lubricating components of the engine.
- When in neutral gear, it is forbidden to let the engine operate with a too high rotation speed.

## How to drive the vehicle

### Start the engine

- Retract the side stand.
- Turn the key to the “” position.
- Make sure the gear is in neutral.

## Caution

The vehicle is equipped with a side-tipping sensor. When the vehicle falls during driving, the engine will stop automatically and the fault indicator lamp will flash. After the motorcycle is restored to the normal position, it is needed to turn the key from “” to “” again to start the engine.

### **Get ready to drive**

- Hold the clutch handle tightly.
- Switch to first gear. Open the accelerator slightly and release the clutch handle slowly.
- When the clutch is fully engaged, it is feasible to step on the gas a little more.
- Please make sure that there is enough fuel to keep the engine operating.

### **Braking**

- Release the accelerator completely and release the clutch to slow down the vehicle.
- Switch to first gear.
- When parking, please ensure that the front and rear brakes are used at the same time. If necessary, the downshift or the complete releasing of the clutch shall be performed to keep the engine from flameout.

- Emergency braking, negligent deceleration and excessive braking force can cause sideslip (sliding)
- Brake lightly when turning and slow down before turning.

### **Turn off the engine**

- Release the accelerator completely
- Switch to neutral gear.
- Turn the key to the “” position.
- Drop the side bracket stand.
- Lock the direction lock.

### **Parking**

- Switch to neutral gear and turn off the power key.
- Use the side stand to park the vehicle on the level ground.
- In case the vehicle is parked in the maintenance room or other buildings, it is needed to make sure that the ventilation is good and there is no flame or spark in the building. These include maintenance operating lamps.
- Lock the direction lock to prevent theft.

### **Daily safety inspection**

It is needed to check the following matters before driving every day to form this habit to ensure the safety and reliability of your vehicle. In case of finding any abnormalities, please read the adjustment chapters or contact your dealer for repair.

Fuel: It should be added properly without leakage.

Engine oil: the oil level should be in the middle of the upper and lower scale lines of the oil observation window.

Tire: tire pressure (cold state)

Front wheel	Load: 243kg	Air pressure: 225kPa
Rear wheel	Load: 243kg	Air pressure: 225kPa

Drive chain: tightness level: 10mm-20mm. It is needed to add lubricating oil when it is dry.

Nuts, bolts, fasteners: Check the torques and tightness levels of control parts, suspension parts, shafts and all control parts.

Control: The action should be flexible and smooth, but the locking parts should not be loose. It cannot be entangled by the control cable.

Braking: In case the brake friction plate is worn, the minimum effective thickness should be greater than 1mm. The brake fluid cannot be leaked.

Accelerator: clearance: 2mm-3mm.

Clutch; clutch handle clearance: 2mm-3mm. The operation of the clutch handle should be flexible.

Coolant: The coolant cannot be leaked and the coolant should be kept between 1 / 3 and 1 / 2 volume.

Electrical installation: All lamps (headlamp, tail lamp/brake lamp, turn lamp, warning/signal indicator lamp) and horn shall be able to operate normally.

It is important to read all warning contents on the vehicle.



## **Special cautions on high speed driving**

**Braking:** Braking is very important when driving at high speed. The braking force should not be too large. It is needed to check and make a proper adjustment to ensure proper braking performance.

**Control:** The looseness of controls may cause the vehicle to lose control. The inspection items should be performed, such as the direction handle should be flexible but not waggle randomly.

**Tire:** When driving at high speed, the key to safe driving is that the tire should be firm and in good condition. It is needed to check the air pressure comprehensively for guaranteeing the stable rotation.

**Fuel:** It is important to ensure sufficient fuel and smooth fuel supply when driving at high speed.

**Engine oil:** To avoid the fault of the engine and the out of control of the vehicle, it is needed to make sure that the oil level is between the upper and lower scale lines of the oil observation window and even as far as possible in the middle.

**Coolant:** To avoid engine overheating, it is needed to check that the coolant level is between 1/3 and 1/2 volume.

**Electrical installation:** It is needed to ensure that all headlamps, tail lamps/brake lights, turn lamps, horns, etc. operate normally.

**Fasteners:** It is needed to ensure all nuts and bolts are tight and all safety-related components are in good condition.

## **Maintenance and adjustment**

### **Regular maintenance chart**

- It must be maintained by professional personnel designated by the Dealer.

\*: The maintenance interval period is determined by the number of total mileage.

#: It is needed to shorten the maintenance period when driving in bad conditions (such as dust, humidity, mud, high-speed driving or frequent starting/flameout, etc.).

1. Regular inspection (engine-related terms)

Matter (engine)	Period Whichever comes first Every other	*The total mileage shows the number km x 1000						
		1	6	12	18	24	30	36
Air filter element - cleaning				●		●		●
Air valve clearance - inspection	42000km							
Accelerator system (clearance, flexible return) - inspection	1 year	●		●		●		●
Idle speed - inspection		●		●		●		●

Fuel leakage (fuel pipeline) - inspection	1 year	●		●		●		●
Fuel pipe damage - inspection	1 year	●		●		●		●
Fuel pipe installation - inspection	1 year	●		●		●		●
Throttle valve body - cleaning			●	●	●	●	●	●
Coolant level - inspection	1 year	●		●		●		●
Coolant leakage -	1 year	●		●		●		●

inspection								
Radiator, water pipe damage - inspection	1 year	●		●		●		●
Air intake system damage - inspection				●		●		●

## 2. Regular inspection (chassis-related terms)

Period Matter (chassis)	Whichever comes first Every other	*The total mileage shows the number km x 1000						
		1	6	12	18	24	30	36
Clutch and drive chain								
Clutch control (clearance,		●		●		●		●

engagement, disengagement)  - inspection								
Drive chain lubrication - inspection #	600km							
Drive chain tightness - inspection #	1000km							
The wearing of drive chain - inspection #				●		●		●
The wearing of the protective card of drive chain - inspection				●		●		●
Rim and tire								
Tire air	1 year							

pressure - inspection		●		●		●		●
Rim / tire damage - inspection				●		●		●
The wearing and the abnormal wearing of tire surface - inspection				●		●		●
Rim bearing damage - inspection	1 year			●		●		●
Pedal - lubrication		●		●		●		●
Chain wheel seat bearing - inspection				●		●		●

Period Matter (chassis)	Whichever comes first Every other	*The total mileage shows the number km x 1000						
		1	6	12	18	24	30	36
<b>Braking system</b>								
Braking fluid leakage - inspection	1 year	●	●	●	●	●	●	●
Braking fluid pipeline damage - inspection	1 year	●	●	●	●	●	●	●
The wearing of			●	●	●	●	●	●



braking plate - inspection #								
Braking fluid pipeline installation - inspection	1 year	●	●	●	●	●	●	●
Braking fluid level - inspection	6 months	●	●	●	●	●	●	●
Braking control (braking force, clearance, flexible action) - inspection	1 year	●	●	●	●	●	●	●

Braking lamp switch operation - inspection		●	●	●	●	●	●	●
<b>Suspension</b>								
Front fork/rear shock absorber (smooth cushioning) - inspection				●		●		●
Front fork/rear shock absorber oil leakage - inspection	1 year			●		●		●

Period Matter (chassis)	Whichever comes first Every other	*The total mileage shows the number km x 1000						
		1	6	12	18	24	30	36
<b>Operating system</b>								
Steering clearance - inspection	1 year	●		●		●		●
Steering bearing - lubrication	2 year			●		●		●
<b>Electric system</b>								
Lighting and switch operation -	1 year			●		●		●

inspection								
Headlamp optical shaft - inspection	1 year			●		●		●
Engine flameout switch operation - inspection	1 year			●		●		●
Alarm system - inspection	1 year			●		●		●
<b>Chassis</b>								
chassis components - lubrication	1 year			●		●		●
Bolt, nut torque -	1 year	●		●		●		●

inspection								
Fuel evaporation system - inspection			●					

### 3、定期更换

#### 3. Regular replacement

Period Replacement matter	Whichever comes first Every other	*The total mileage shows the number km x 1000				
		1	12	24	36	48
Air filter element #	2 years					
Engine oil #	Half a year	Every other 3000km (500km for the first time)				
Oil filter	Half a year	Every other 6000km				
Fuel pipe	4 years					●

Coolant	2 years				●	
Radiator, water pipe	2 years				●	
Braking fluid pipeline	4 years					●
Braking fluid (front/rear)	2 years			●		●
Rubber seal of the main pump	4 years					●
Sparking plug			●	●	●	●
Buffer block of chain wheel seat			●	●	●	●

## **Engine oil**

To guarantee the normal operation of the engine, transmission mechanism and clutch and other moving parts, it is necessary to ensure that the oil level in the engine is between the upper and lower scale lines of the oil observation window. Besides, it is needed to perform the inspection and replacement according to the regular maintenance chart. In the process of lubrication for a long time, it will not only produce dirt and metal impurities but also consume itself.

### **Level inspection of oil volume**

- After the oil is changed, it is needed to start the engine and operate at idle speed for a few minutes to fill the oil filter with oil. Later, it is time to turn off the engine and wait a few minutes until the oil deposits.
- In case the vehicle is just in use, it is necessary to wait a few minutes to drain the engine oil.
- It is needed to check the engine oil level through the oil observation window. In case of parking the vehicle on the level ground, the oil level must be between the upper and lower scale lines of the oil observation window.
- In case the oil level is too high, it is needed to drain the excess oil.
- In case the oil level is too low, it is needed to add the same type of oil to the middle of the upper and lower scale lines of the oil observation window.

### **Change engine oil and oil filter**

- Park the car on the level ground.
- Operate the engine first and then stop the engine when it is hot.
- Place the oil pan in the oil draining position.
- Remove the oil draining bolt.

- Drain the oil thoroughly.
- Remove the oil filter and replace it with a new one.
- Apply a thin oil film on the sealing ring and tighten it according to the specified torque.
- Install the oil draining bolt with a new washer.
- Use the high-quality oil listed below and add it to the middle of the upper and lower scale lines of the oil observation window.
- Start the engine.
- Check the oil volume level and oil leakage.

### **Torque tightening**

Oil draining bolt: 30N·m Oil filter: 17.2N·m

### **Recommended oil:**

Type: SJ level JASO MA2 certified oil Viscosity: ELF Company 10W-40.

Oil volume of engine:

When the oil filter is not changed: 2.0L

When the oil filter is changed: 2.2L

When the engine oil is completely drained: 2.6L is required to use APISH level oil and above. The first choice is JASO MA2 certified oil and the second is JASO Ma certified oil.

Although 10W-40 is one of the recommended oils to meet most ambient temperature conditions by us. It is needed to change the viscosity of the oil when the ambient temperature condition changes in your driving area. Please make a choice according to the table below.



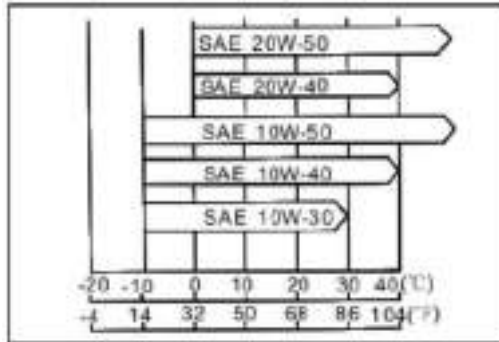

## Cooling system

### Radiator and cooling fan

It is important to check whether the radiating fin is deformed or blocked by sediment and clean the radiator with tap water.

### Radiator pipeline

Before daily driving, it is important to check whether the radiator pipeline is leaked, cracked, aged and rusted and whether the joint is leaked or loose, etc. Besides, it is needed to regularly perform the inspection according to the maintenance chart.

### Coolant

The coolant absorbs the heat from the engine and is discharged into the atmosphere through the radiator. In case the coolant level is too low, the engine will overheat and can seriously damage the engine. It is significant to check the coolant level before daily driving and check it regularly according to the maintenance chart. In case the coolant level is too low, the coolant should be added according to the maintenance chart.

### **Level inspection of coolant**

- Keep the longitudinal plane of the car body perpendicular to the horizontal ground.
- Check whether the coolant level is between 1/3 and 1/2 volume
- In case the coolant is less than 1/3, the coolant should be added to 1/2 volume.

### **Add coolant**

- Open the auxiliary water tank cover and add coolant to 1/2 volume.
- Close the auxiliary water tank cover.

## **Accelerator control system**

It is needed to check the clearance of the accelerator and handle according to the regular maintenance chart and adjust it if necessary.

### **Accelerator handlebar**

The accelerator handlebar controls the throttle valve body. In case the clearance between the accelerator and handlebar is too large, the accelerator action will be inharmonious, which indicates that the accelerator wire cable is too long. This will cause the slow response of the accelerator, especially when the engine is at low speed. When the handlebar is turned to the maximum, the throttle is not fully opened. In case the clearance between the accelerator and

handlebar is too small, the control of the accelerator wire cable will too tight and the idle speed will too high or unstable.

### Inspection

- Check the clearance between the accelerator and handlebar.

The accelerator handlebar should rotate flexibly.

- In case the clearance between the accelerator and handlebar is not proper, it is needed to make an adjustment.

Accelerator handlebar
The clearance between the accelerator and handlebar
The clearance between the accelerator and handlebar: 2mm-3mm

### Adjustment

Locking nut
Adjusting nut

- Loosen the locking nut of the fuel door cable on the right handlebar switch and turn the adjusting nut of the fuel door cable to make the clearance between the accelerator and handlebar suitable.

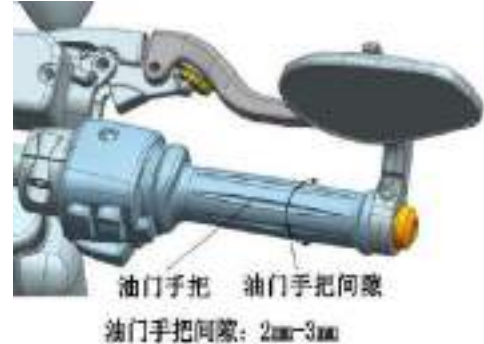

- Adjust the clearance of the return fuel door cable until the accelerator handlebar is fully returned to the proper position.
- The locking nut should be tightened.
- Loosen the locking nut of the fuel return door and turn the adjusting nut of the fuel return door until the accelerator handlebar is at 2mm-3mm.
- The locking nut should be tightened.

## Clutch

In the process of long-term use, the friction plate of the clutch will be worn and the clutch cable will be extended. Therefore, the operation performance of the clutch must be checked before daily driving in accordance with the regular maintenance chart.

- Check the operation performance of the clutch handle. The cable should operate flexibly.  
In case the clutch operates abnormally, please contact your dealer for inspection.
- Check the clearance of the clutch and handle.

Clearance: 2mm-3mm. In case the clearance is not correct, it is needed to adjust the clearance of the clutch and handle.

### Adjustment

- Loosen the locking nut and turn the adjusting nut to make the clearance of the clutch and handle suitable.

Adjusting nut



Locking nut
Clutch handle
Clearance

- In case the handle end of the clutch cable is adjusted to the limit position and cannot meet the requirements of the handle clearance, it is needed to adjust the adjusting nut between the cable and the engine end.

## Drive chain

It is needed to check the tightness level and lubrication of the drive chain before daily driving. Besides, the safety matters specified in regular maintenance provisions should be followed to prevent excessive wearing of the drive chain. In case the drive chain is excessively worn or improperly adjusted, the chain will be too loose or tight. Consequently, the chain will be fallen off or the resistance is produced.



Locking nut of chain
Adjusting nut of chain
Rear axle shaft nut

### Chain tightness inspection

- Support the vehicle with a stand.

- Rotate the rear wheel to check whether the chain is too tight and press the middle of the chain to measure the distance between upward and downward tightness.
  - In case the chain is too loose or too tight, it is needed to adjust it to the standard value.
- Standard value: 10mm-20mm

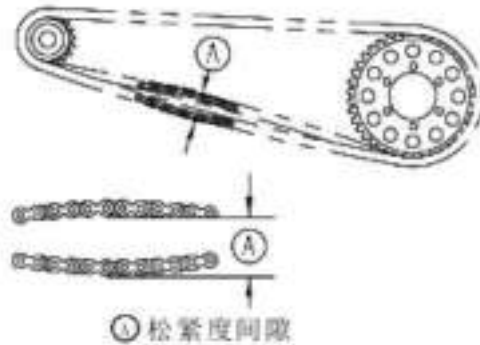

Tightness clearance

### Adjustment

- Insert lifting pin into the inner hole at both ends of the rear axle shaft.
- Support the vehicle with the frame.
- Loosen the locking nut of the chain adjuster.

- Loosen the locking nut of the rear axle shaft.
- In case the chain is too loose, it is needed to turn the left and right adjusting nuts clockwise and the left and right adjustment levels should be equal.
- In case the chain is too tight, it is needed to turn the left and right adjusting nuts anticlockwise and the left and right adjustment levels should be equal.
- Turn the adjusting nut until the chain tightness is adjusted properly.
- Ensure that the displacement of the rear axle shaft on the rear fork is consistent.
- Lock the locking nuts of left and right chain adjusters.
- Lock the rear axle shaft nuts according to the specified torque.
- The torque of rear axle shaft nut: 120N·m

## Braking

### Braking oil cup

It is needed to check the horizontal fluid level in the front and rear braking oil cups according to the regular maintenance chart and replace it with new braking fluid. When the braking fluid is contaminated or seeped into the water, it must be replaced with a new one.

### Braking fluid requirements

Use only the DOT4 braking fluid type indicated on the oil cup.

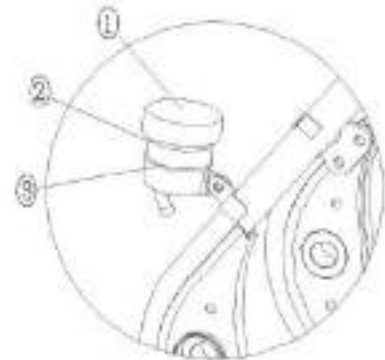

## Level inspection of braking fluid

It is needed to check whether the water levels of braking fluid in the front and rear braking oil cups are between the upper and lower scale lines.

Front braking oil cup cap
Front braking oil cup
Oil window

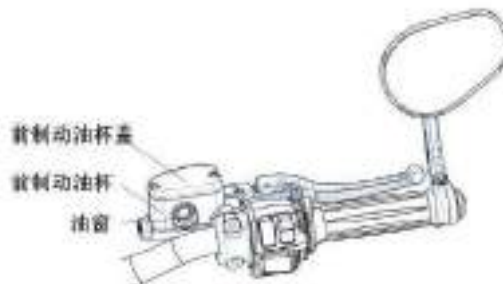

- In case the water level of the braking fluid is lower than the lower scale line, it is needed to check the braking fluid pipeline for leakage and add braking fluid to the upper scale line of the oil cup. The upper scale line of the front braking oil cup is on the inside, which can be seen only when the oil cup cover is opened.

① Rear braking oil cup ② upper scale line ③ lower scale line

## Check the shock absorber

- Compress the seat cushion several times to check whether it operates smoothly.
- Observe the shock absorber for leakage.



- In case of any problems with the shock absorber, it is needed to contact your dealer.

## Preload load adjustment of rear shock absorber spring 旋转调整

Pre-load rotation adjustment



Rotation adjustment

## Tire

### Load and tire air pressure

Improper tire air pressure or the air pressure exceeding the tire load limit may affect the control and vehicle performance and cause loss of control.

- Remove the air valve cover.
- Use a barometer to measure tire air pressure regularly.
- Make sure the air valve cover is installed tightly.

### Tire air pressure (cold state)

Front wheel	225Kpa
Rear wheel	225Kpa

# Battery

## Battery maintenance

The user must ensure that the battery is fully charged. Otherwise, the battery will be damaged. In case you drive your vehicle rarely, you must use a voltmeter to check the battery voltage every week. In case the battery voltage is lower than 12.8V, the battery must be charged with a charger (Please contact your dealer for inspection). In case you do not use the vehicle for more than two weeks, you must use a charger to charge the battery. It is forbidden to use the automatic quick charger to charge the battery. Otherwise, it may cause battery overload and damage the battery.

## Battery charging

- Remove the battery from the vehicle.
- Connect the charger lead and make sure that the charging current is 1/10A of the volume of the battery. For example, in case of charging the battery with a volume of 20Ah, the charging current should be 2A.
- In case you put the battery back in the vehicle, it is needed to make sure the battery is fully charged.

## Battery removing

- Remove the side cover on the right side of the main seat first.
- Pull down the rubber band of the battery box to release the fixing ring from the hook on the battery box.
- Remove the positive and negative cables from the battery and take out the battery.
- Clean the wiring terminal of the battery with carbonated water and water and clean the wiring terminals of the positive and negative cables.

## Battery installation

- Put the battery in the battery box.
- Connect the positive pole of the battery and then connect the negative pole of the battery.
- After the positive and negative poles are connected, the wiring terminals and terminals shall be coated with conductive grease to prevent corrosion.
- Cover the positive and negative pole sleeves.
- Reinstall the removed parts.



## Common faults and causes of motorcycle

Condition	Component position	Fault cause	Disposal method
Unable to start	Fuel system	There is no fuel in the tank	Add fuel
		The oil pump is blocked or damaged. The fuel quality is poor	Clean or replace
	Ignition system	Fault of sparking plug: too many deposited carbon and long service time	Check or replace
		Fault of sparking plug cap: poor contact or burning	Check or replace
		Ignition coil fault: poor contact or burning	Check or replace
		ECU fault: poor contact or burning	Check or replace
		Coil fault triggering: poor contact or burning	Check or replace
		Stator fault: poor contact or burning	Check or replace
		Faults of all connecting wires: poor contact	Check or adjust
			Check or replace

Unable to start			Check or replace
			Check or replace
			Check or replace
Insufficient power	Air valve piston	Excessive carbon deposited in intake, exhaust valve and piston: poor fuel quality and poor oil quality	Repair or replace
	Clutch	Clutch slipping: poor oil quality, long service time and overload	Adjust or replace
	Cylinder body and piston ring	Wearing of cylinder body and piston ring: poor oil quality and long service time	Replace oil
	Brake	In complete brake separation: too tight brake	Adjust
	Big chain	Too tight drive chain: improper adjustment	Adjust
	Engine	Engine overheating: over-rich mixture or over-thin mixture, the poor quality of oil and fuel, obstructions, etc.	Adjust or replace
	Sparking plug	Improper sparking plug clearance. The normal value: 0.8-0.9 mm	Adjust or replace
	Air intake pipe	Air leakage of air intake pipe: too long service time	Adjust or replace
	Air cylinder head	Air cylinder head or air valve is leaked	Check or replace
Electric system	The fault occurs in the electric system	Check or repair	

	Air filter	The air filter is blocked	Clean or adjust
The headlamp and tail lamp do not lighten	Cable	The poor contact occurs in the circuit	Adjust
	Left and right switches	The poor contact occurs in the switch or the switch is damaged	Adjust or replace
	Headlamp	Inspection of bulb and lamp seat	Adjust or replace
	Voltage regulator	Inspection of voltage regulator; poor contact or burning	Check or replace
	Magneto	Inspection of magneto coil; poor contact or burning	Check or replace
The horn does not sound	Battery	There is no sufficient electric quantity in the battery	Charge or replace
	Left switch	Inspection of the horn button	Adjust or replace
	Cable	The poor contact occurs in the circuit	Adjust or repair
	Horn	The horn is damaged	Adjust or replace

The items listed above are the common faults of the motorcycle. In case your motorcycle breaks down (especially in the electronic fuel injection system, fuel evaporation system and alarm system), please contact the “Dealer” promptly for timely inspection and repair.

Users should remember the following contents: It is forbidden to deal with motorcycle’s faults by themselves. Otherwise, it is easy to cause safety hazards or accidents. In case the users handle the motorcycle’s faults by themselves, the users shall be responsible for the safety accidents.