



January 1980

MC 250 Typ 346
MC 400 Typ 347
MC 440 Typ 348

Technical data, owners manual, spare parts catalogue

MAICO-Fahrzeugfabrik GmbH 7403 Ammerbuch 2

Made in West Germany

Telefon (0 70 73) 824/825 Telex 7262746

IMPORTANT INFORMATION - SAFETY NOTICE

Maico is not responsible for personal injury or damage to the components of the machine. Maico is not responsible for any damage resulting from using methods or tools or performing work other than that recommended and/or authorized by Maico U. S. A.

This motocross machine is especially constructed for competition and off-road use only. This machine is sold as is with original equipment. This machine does not conform to Federal Safety Standards and operation on public streets, roads or highway is illegal.

Maico reserves the right to make changes at anytime without notice and without incurring any obligation whatsoever.

No part of this publication may be reproduced or copied without written permission from Maico U. S. A.

WARRANTY INFORMATION

Maico motorcycles are sold on an "As Is" basis and therefore there are no warranties expressed or implied. The Purchaser of this motorcycle, which is intended for competition purposes, is responsible for all cost of service and/or repair.

Maico U. S. A
 Maico Fahrzeugfabrik GMBH



Contents

- 1. Preface
- 11. Technical Data
- 111. Service Instructions
 - 1.1 Service instructions before the test run.
 - 1.2. Service instructions after one hour run.
 - 1.3. Torque specifications
 - 2.0 Motoplat - pointless ignition
 - 3.0 Carburetor
 - 4.0 Air filter
 - 5.0 Clutch - primary chain - transmission
 - 6.0 Telescopic fork - steering
 - 7.0 Rear suspension - Shock absorber - Swing arm bearings
 - 8.0 Wheels
 - 9.0 Chain
 - 10.0 Brakes
 - 11.0 Cables
 - 12.0 Fuel lines
 - 13.0 Lubrication
 - 14.0 Cylinder - piston
 - 15.0 Crankshaft - connecting rod
 - 16.0 Explosion chart engine
 - 16.1 Parts description of the engine
 - 17.0 Explosion chart chassis (I,II)
 - 17.1 Parts description chassis
 - 18.0 Explosion chart carburetor
 - 18.1 Parts description carburetor
 - 19.0 Measurements of motorcycle



1. Preface:

This short instruction manual conveys the most important information for proper maintenance and use of following MX models: MAICO MC 250, 400, 440. These models are especially constructed for competition and off-road use. The MAICO motorcycles feature high performance engines, specially tuned chassis, and are light weight. The chassis of this series has been newly designed. The suspension with extremely long wheel travel has been tuned for use in competition.

The sturdy light weight 5/speed engine was improved as far as endurance and shifting is concerned.

The above mentioned motorcycles can only maintain their performance if they receive regular and correct service.

This instruction manual, combined with basic mechanical knowledge will assure trouble-free operation.



11. Technical Data:

Model Row	MC 250 Type 346	MC 400 Type 347	MC 440 Type 348
Engine Type	250 ccm Type 346	400 ccm Type 347	440 ccm Type 348
Main Measurements of Motorcycle:			
Max. Length:	2150 mm		
Max. Width:	850 mm		
Max. Height:	1290 mm		
Wheel Base:	1446 - 1482 mm		
Seat Height:	960 mm		
Ground Clearance:	360 mm		
Dry Weight:	99 kg (218 lbs)	101kg (223 lbs)	102kg (225 lbs)
Motor:			
Type	Air cooled, single cylinder, two stroke. loop scavenging, piston port, engine.		
Bore & Stroke:	67 x 70 mm	77 x 83 mm	82 x 83 mm
Displacement:	247 ccm	386 ccm	438 ccm
Compression Ratio:	12 : 1	12 : 1	12 : 1
Horse Power (DIN):	40 hp - 28 kw (40PS) @ 8000 rpm	47 hp - 31.5 kw (47PS) @ 7000 rpm	50 hp - 34.5 kw (50PS) @ 7200 rpm
Max. Torque:	36.3 Torque (3.7 mkp) @ 6800 rpm	49.1 Torque (5 mkp) @ 6200 rpm	51 Torque (5.2 mkp) @ 6000 rpm

Typenreihe:	MC 250 Typ 346	MC 400 Typ 347	MC 440 Typ 348
Vergaser:	Bing Typ V 54	Bing Typ V 54	Bing Typ V 54
Durchlaßquerschnitt:	Ø 40 mm	Ø 40 mm	Ø 40 mm
Gasschieber:	1204	1201	1201
(Kennzahl)	ohne Luftschieber		
Hauptdüse:	195 - 205	185 - 195	185 - 195
Nadeldüse:	276 - 2	278 - 2	278 - 2
Leerlaufdüse:	50 - 60	45	45
Nadelposition:	je nach Bedarf		
Leerlauf Luftschraube:	1 Umdrehung - oder nach Bedarf		
Kraftstoff:	Super Kraftstoff mit Öl vorgemischt		
Mischverhältnis:	20 : 1 mit gewöhnlichem Zweitaktoel 40 : 1 bei Verwendung hochwertiger Mischöle, z.B. Castrol Super TT		
	100 : 1 mit MAICO MC - GP - 100 Mischöel		
Zündung:	Motoplat kontaktlose Zündanlage		
Vorzündung:	1,6 ± 0,1 v. OT	2,1 ± 0,1 v. OT	2,1 ± 0,1 v. OT
Zündkerze:	Champion N 2 oder N 2 G (Wärmewert 280-310)		
Kupplung:	Öelbadkupplung mit 6 sinterbelegten Außenlamellen und 6 Innenlamellen aus Federstahl		
Primärtrieb:	Durch Kette Renold 3/8" x 7/32" 52 Glieder endlos Duplex		Triplex
Primärübersetzung:	41/18 = 2,28	39/21 = 1,86	39/21 = 1,86
Sekundärübersetzung:	56/14 = 4,0 Antriebsritzel auch mit Z = 12 bzw. Z = 14 erhältlich zur individuellen Abstimmung	56/13 = 4,30	56/13 = 4,30
Getriebe:	Klauengeschaltetes 5-Gang-Getriebe mit Haupt- und Vorgelegewelle		

Gear Lube: 600 cm³ - Engine oil SAE 20W - 50W.

The other oils with different viscosity are not recommended.
Shifting: With 3 shifting forks, shifting plate operates through shifting cam with engaged hooked ratchet; Left foot operated.

Transmission Ratio MC:

Symbol and Type:

Symbol and Type:	MT 1	RT	RT
1st Gear	2.25 (20.53)	2.71 (21.70)	2.71 (20.15)
2nd Gear	1.80 (16.43)	1.97 (15.81)	1.97 (14.68)
3rd Gear	1.44 (13.13)	1.50 (12.03)	1.50 (11.17)
4th Gear	1.20 (10.97)	1.20 (9.63)	1.20 (8.95)
5th Gear	1.00 (9.11)	1.00 (8.00)	1.00 (7.43)

() - Overall ratios with i sec = 56/14

Drive chain

5/8" x 1/4"	5/8" x 1/4"	5/8" x 1/4"
108 links with lock	108 links with lock	108 links with lock
with master link	with master link	with master link

Tank: Centrifugal molding plastic tank.
Unbreakable competition approved with 9.5 (2.5 USgal.)
Liter capacity.

Petcock: Three way petcock with larger outlet filter by a screen filter.

Air Filter: Large volume, foam filter, oiled with SAE 10. Inside the air box.

Exhaust system: Built in muffler - meets FIM - AMA rules
For moto-cross 90-92 dBA
Mufflers are rebuildable with packing: (Fiberglass or steelwool)

Color: Frame, Fenders, Tank, Number Plates are red.

Model Plate: Stamped on the steering head

Chassis No: Stamped on the steering head



111

Service Instructions

1.1 Preparation before the race.

- Transmission - check the oil level.
- Check the clutch lever play.
- Check the spark plug for tightness.
- Check the carburetor clamps and the rubber sleeve clamps. Do not over tighten the carburetor rubber manifold. It could cause the rubber to crack.
- Check the throttle cable play. Check the throttle slide for free and complete closing.
- Check the kill button for proper function.
- Check the air filter to see if its oiled - never run the engine when the air filter is dry.
- Check the chain tension and adjust if necessary. When lifting the chain up, chain should touch the upper chain guide bush. Chain slack should be 5 - 7 cm
- Check the decompressor lever for proper play.
- Check all the nuts and bolts for tightness.
- Check the oil drain plug and detent plug for tightness.
- Check the air pressure on the front forks and tires.
- Check the spokes for tightness.
- Check the brakes for function and check the play.

1.2 Service after the 1st test run (e 1 hour)

- Retighten the cylinder head, cylinder base. (see torque specifications)
- Check the engine mounting bolts for tightness.
- Check the magneto nut for tightness and check the timing.
- Check the oil level.
- Tighten the rear axle nut, front axle and swing arm axle nut.
- Check all the bolts and nuts for tightness.
- Check the front and rear spokes for tightness.
- Check the chain for proper play and lube the chain.
- Check the steering head plug, tighten if necessary.
- Drain the fork oil and clean the fork and change the fork oil (see fork information).
- Check the air filter. Clean and oil it.

10

1.3 Torque Specifications	Fastener Dimension	Metric Std.		American English Std.	
1. Crankshaft nut	M 25 X 1,5	196,2 Nm	(20 kpm)	144,6	Ft.1b
2. Clutch nut (on mainshaft)	M 12 X 1,5	68,7 Nm	(7 kpm)	50,6	Ft.1b
3. * Magnet rotor nut	M 12 X 1	68,7 Nm	(7 kpm)	50,6	Ft.1b
4. Cylinder head studs	M 10	24,5 Nm	(2,5 kpm)	18,0	Ft.1b
5. Cylinder head nuts	M 8	24,5 Nm	(2,5 kpm)	18,0	Ft.1b
6. Cylinder base studs	M 8	19,6 Nm	(2 kpm)	14,5	Ft.1b
7. Cylinder base nut	M 8	19,6-24,5 Nm	(2-2,5 kpm)	14,5-18	Ft.1b
8. Shifting mechanism detent bolts and cam guide bolts	M 14 X 1,5	24,5-29,4 Nm	(2,5-3,0 kpm)	18-21,7	Ft.1b
9. Crankcase cover screws (not applied on the right hand crankcase cover)	M 6	8,8 Nm	(0,9 kpm)	6,5	Ft.1b
10. Armature plate screws	M 5	4,9 Nm	(0,5 kpm)	3,6	Ft.1b
11. Engine mounting bolt	M 8	24,5 Nm	(2,5 kpm)	18	Ft.1b
12. Engine yoke	M 8	24,5 Nm	(2,5 kpm)	18	Ft.1b
13. Front axle	M 14 X 1,5	39,2 Nm	(4,0 kpm)	29	Ft.1b
14. Swing arm nut	M 14 X 1,5	63,8 Nm	(6,5 kpm)	47	Ft.1b
15. Rear axle nut	M 16 X 1,5	73,6 Nm	(7,5 kpm)	54,2	Ft.1b
16. Dampening rod bolts	M 8	19,6 Nm	(2,0 kpm)	14,5	Ft.1b
17. Steering head nuts	M 27 X 1	play free			
18. Pinch bolts for the fork tubes	M 10	39,2-44,1 Nm	(4,0-4,5 kpm)	29-32,5	Ft.1b
19. Front axle pinch bolts	M 6	8,8 Nm	(0,9 kpm)	7,5	Ft.1b
20. Front brake backing plate stop arm bolt	M 8	19,6 Nm	(2,0 kpm)	14,5	Ft.1b
21. Rear brake backing plate stop arm bolt	M 8	19,6-24,5 Nm	(2-2,5 kpm)	14,5-18	Ft.1b
22. Rear brake backing plate stop arm bolt	M 10	39,2 Nm	(4,0 kpm)	29	Ft.1b
24. * Left hand threaded					

2.0 Ignition

Check the timing after 5 races. (for timing information see the Technical data).

CAUTION

Ignition coil must always be grounded to the frame, solid mounting, without silent block or ground wires. Never kick or turn engine with disconnected spark plug cap. Spark plug must always be grounded. (Ignition will be destroyed if electrical is incomplete). Never pull spark plug cap when engine runs. When ignition is defective always exchange both stator and rotor together - otherwise, timing marks will not match. Connectors should be covered with the special grease to protect from connection.

The proper timing set is set by a dial indicator. The dial indicator is either screwed into the vertical spark plug hole or mounted to one of the cylinder head studs with a special fastening plate, if the head is removed. The crankshaft is rotated approximately 45° counter clockwise. Turning the magneto counter clockwise to the specified timing measurement (see specifications) in this position, the mark on the stator place should match the mark on the magneto rotor. (see the picture).

In order to retard the timing, turn the stator in the clockwise direction: to advance the timing turn the stator plate counter clockwise. After tightening the screws check the timing again. Timing marks also can be checked by the timing light pistol.

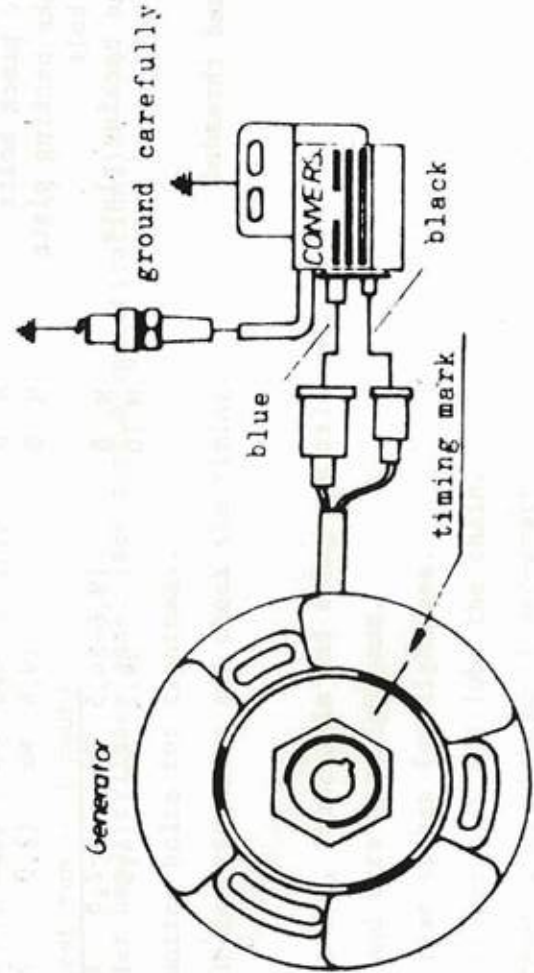

3.0 Carburetor and Jetting System:

The best performance and engine output depends on fine adjustment of the carburetor for various working conditions, such as altitude and temperature. Improper adjustment of the carburetor causes the engine to perform below its actual output.

Carburetor Functions Under Following Systems

Pilot (idle) jet - functions up to 25% throttle slide opening, air regulating screw (small screw) regulates fine adjustment of idle mixture.

Needle jet - functions from 15% to about 80% of throttle slide opening. Fine adjustment is carried out by altering the needle position.

Main jet - functions from 50% to 100% of throttle slide opening.

Adjustment of the Carburetor

All the adjustments should be made only on a warmed up engine. Always change one component only, then test ride again.

The basic carburetor jet is valued for 1200 feet above sea level and temperature between 18°C - 25°C (64°F - 77°F) with recommended oil mixture.

Pilot System:

- Functions when throttle slide is closed. The throttle slide stop screw (idling screw) adjusts idling rpm-approximately 1000 rpm. Clean idling is regulated with air regulating screw (small screw). Turning the screw further in gives a richer idling mixture: turning the screw further out gives a leaner idling mixture. When bike is in motion with throttle slide closed and engine idles too fast (lean mixture), use the next larger pilot jet.

Midrange:

- Functions with throttle slide partially open. Adjustments are made with needle jet and needle position. Adjustment is influenced by pilot system for bottom end, and by the main jet for top end.

If mixture is too rich during acceleration, the needle should be lowered. When engine pings (metallic knocking) during acceleration, the needle should be raised. If lowering or raising of needle is not sufficient, install smaller or larger needle jet.

Midrange During Acceleration:

- Functions from idling to throttle wide open. During acceleration, engine output should increase steadily. If power comes on unevenly, or all of a sudden at high rpm, or engine smokes, pilot system or needle jet system is too rich. When engine pings during acceleration, the needle should be raised. If raising of needle is not sufficient, use larger needle jet.

Top End:

- Throttle slide wide open. When engine pings in wide open position (spark plug white), use larger main jet. Installation of larger main jet requires also larger needle jet, so that fuel flow is not restricted by needle jet. If engine runs to rich (spark plug dark), use smaller main jet.

IMPORTANT:

In order to prevent engine seizures, always start with larger jets first, then try next smaller size.

At temperatures below 10°C (50°F) or low altitudes (0 - 300 feet above sea level), use one or two sizes larger main jet. At high temperatures or high altitudes, use smaller main jets.

An irregularly running engine will cause the piston and cylinder to over heat. This condition is suspected of having an adverse effect causing seizure and severe damage to the engine, so it is necessary to check the deck height of the cylinder to prevent abnormal combustion, preignition and knocking noise of the engine.

5.0 Clutch - Primary Chain - Transmission:

Check clutch for functioning. If necessary, replace fatigued clutch springs or clutch plates.

The clutch handlebar lever is adjusted so that there is 2-3mm play in it. The primary chain is checked for excess stretch (Double sag) 25mm.

The magnet of the oil drain plug should be checked frequently for excessive metal chips. If so, find defect and replace necessary parts.

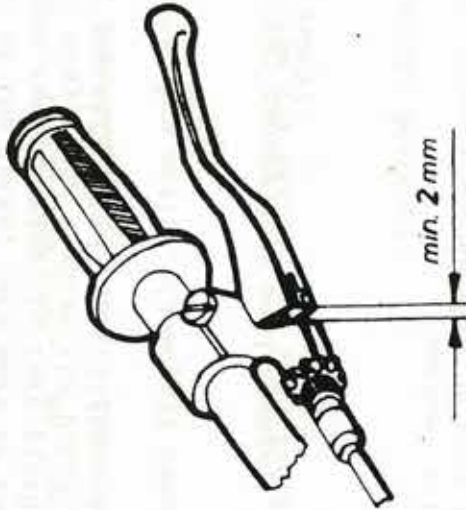

Clutch lever adjustment

Change the oil every 3 races.

CAUTION:

Do not use hammer on clutch lock washer tool to secure the clutch washer on this new engine. Bend the lock washer carefully with tool by applying 2 way puller. In order to avoid damage of the clutch bearing holding plate, never hit the clutch bearing.

6.0 Telescopic Fork Steering:

Fork tubes are made of $\varnothing 42$ mm fork sliders with 2 seals and removable guide bush. Fork travel 310mm, progressively operating dampening unit with linear wound springs. Linear wound spring is assisted by compressed air (1 atu - 14 psi) change the oil after every 5 races.

The oil capacity of 570 ccm per leg. HL 25 or ATF oil. (SAE 10) LT 100.

Proper oil level should be measured 16 cm from the upper edge of the fork tube. Measurement should be made without spring. Fork should be compressed fully.

Oil capacity and air pressure can be varied depending on body weight and track conditions.
(+ 20cc oil volume; \pm 0.2 atu 2.8 psi air pressure)

Less oil	Softer fork.	Less air pressure	Softer fork.
More oil	Harder fork.	More air pressure	Harder fork.

The forks should be maintained carefully. Both fork tubes should be taken out of the triple clamps. The play of the steering head bearings should be checked and adjusted. The individual fork tubes and damper tubes are checked for bend. The chrome surface of the fork tubes are visually checked for scars and scratches. The fork seals should be replaced if there is any breakage. During reassembly of the forks, care must be taken that there is no pressure on the fork tubes or sliders after retightening the fork pinch bolts and the front axle. First adjust steering head bearing play, then tighten the pinch bolts of upper triple clamp. Make sure there is no tension on fork sliders. First tighten axle then tighten pinch nuts on fork sliders.

CAUTION:

Do not apply high pressure air on the forks: causes fork seal damage. Check for air leak on the valve (tighten or replace if necessary).

7.0 Rear Suspension - Shock absorbers - Swing arm Bearings:

The rear suspension is effected by a long swing arm supported by wide frame mounts on gas shocks. The needle bearings of the swing arm should be greased or oiled now and then. A properly functioning rear suspension gives maximum performance of the motorcycle in difficult terrain. Check for equal dampening on both shocks. Then check shock mounts - and replace if necessary. Light yellow, later blue damper rods indicate overstress of shocks.

8.0 The wheels must be centered exactly. All spokes must be free of damage and tightened equally. The wheel bearings are checked for play and sealing. The brake shoes and brake drum are clean with a steel brush or emery cloth.

9.0 Chain:

To insure long chain life, only quality chains are recommended - 5/8" x 1/4" with 108 links with master link. Clean chain frequently. Wash chain with solvent and boil in MoS2 grease.

Chain slack is 5 - 7 cm .Chain should not be too tight when fully bottomed up.

Check wear of guide rail on the chain guide and rollers and replace if necessary.

10.0 Check the brake shoes frequently, clean and adjust.

11.0 Cables:

Cables should be lubricated and checked for wear and bends. Inject thin oil. Replace if necessary.

12.0 Fuel lines:

Check fuel lines for leakage.

Petcock:

The petcock is provided with a screen filter. This filter should be cleaned frequently.

NOTE: Use only petcock with large outlet to avoid engine seizures!

13.0 Lubrication:

Transmission oil change:

- a) Warm up engine, remove oil drain plug SW17 (Picture No 17) on the left hand crankcase cover - bottom
- b) Tighten oil drain plug with sealing ring, remove oil filling plug SW 19 (Picture No 19), from left hand crankcase cover.
- c) Remove oil level screw (Picture No 21) from left hand crankcase cover below the MAICO letters.

Fill recommended oil (see technical data) until visible at oil level hole. Tighten oil filling plug and oil level screw with sealing ring.

Oil Change Front Fork:

- a) Remove oil drain screw SW 13 from lower fork slider.
- b) Retighten oil drain screw with sealing ring, loosen upper pinch bolts, then remove breather cap from top of fork tube.
- c) Fill specified volume. See technical data. Retighten cap.
- d) Follow procedure on both fork legs. Check fork for proper function.

.0 Cylinder - Piston:

The cylinder is light alloy with shrunken cast iron cylinder sleeve. The cylinder base gasket is *0.5mm thick. (Abill - gasket). The cylinder head gasket is 0.6mm co -sheet metal. The Maico piston is made with a special forged piston and coated by a high volume of silicone mixture. This piston is provided with only one L ring. The piston oversizes varied from 0.15mm part.

Measurement Chart Cylinder - Piston

	250	400	440
Piston	0.05 - 0.06mm	0.06 - 0.08mm	0.08 - 0.09mm
Std.	Piston ø 66.95mm	Piston ø 76.95mm	Piston ø 81.95mm
1st Over	Piston ø 67.10mm	Piston ø 77.10mm	Piston ø 82.10mm

The largest oversizes are following piston diameters:

ø 68mm, ø 78mm, ø 83mm

*Base gaskets also available in 0.3mm, 0.7mm thickness for variable deck height. Deck height is measured from the cylinder sleeve head gasket surface to the top edge of the piston ring. (0.4mm to 0.65mm).

Cylinder Reboring:

Cylinders should be rebored if excess piston play, oval (maximum tolerance 0.03mm), seizure marks or damage on working surface is indicated after boring, deburr the edges of the ports.

15.0 Crankshaft - Connecting rod:

The crankshaft halves are forged and received heat treatment after machining. The right half of the crankshaft (magnet side) has a conical profile, the left half (primary crive side) has a splined shaft profile.

The connecting rod is forged and has tempered needle bearing seating.

The allowed radial play tolerance are for

- Big end Bearing 0.03mm - 0.04mm
 - Piston pin bearing 0.002mm - 0.004mm
- Play should be checked before inserting the crankshaft.

It is recommended to only use original Maico spare parts, since this bearing is specially made for Maico engines.

Check crankshaft as shown in sketch.

Maximum connecting rod play A : 3mm

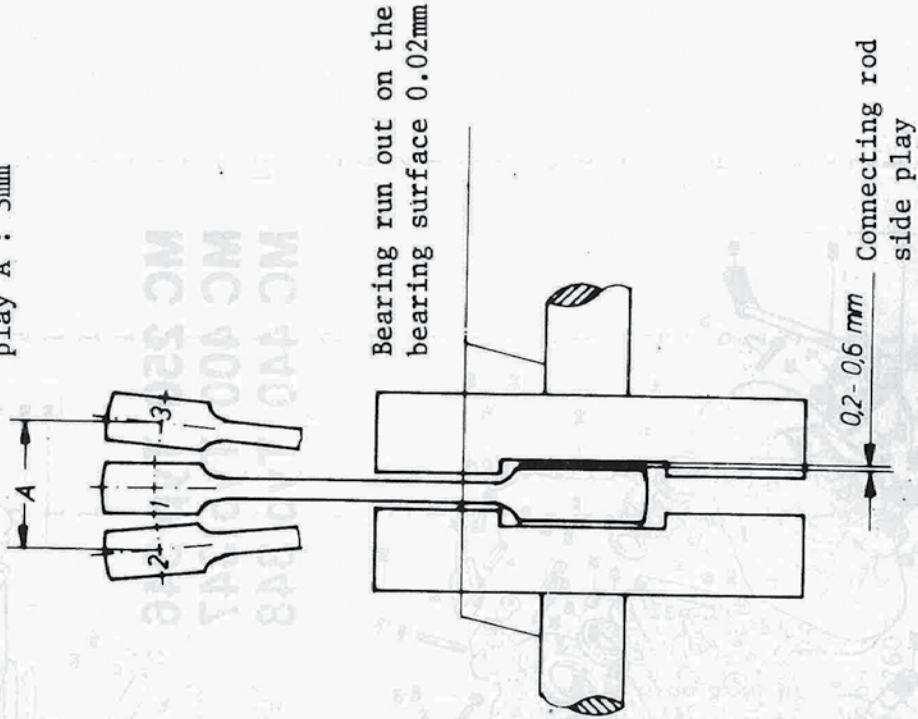

MAICO
Fahzeugfabrik GmbH 74003 Ammerbuch 2
Telefon 07143 8244233, Telex 7383146

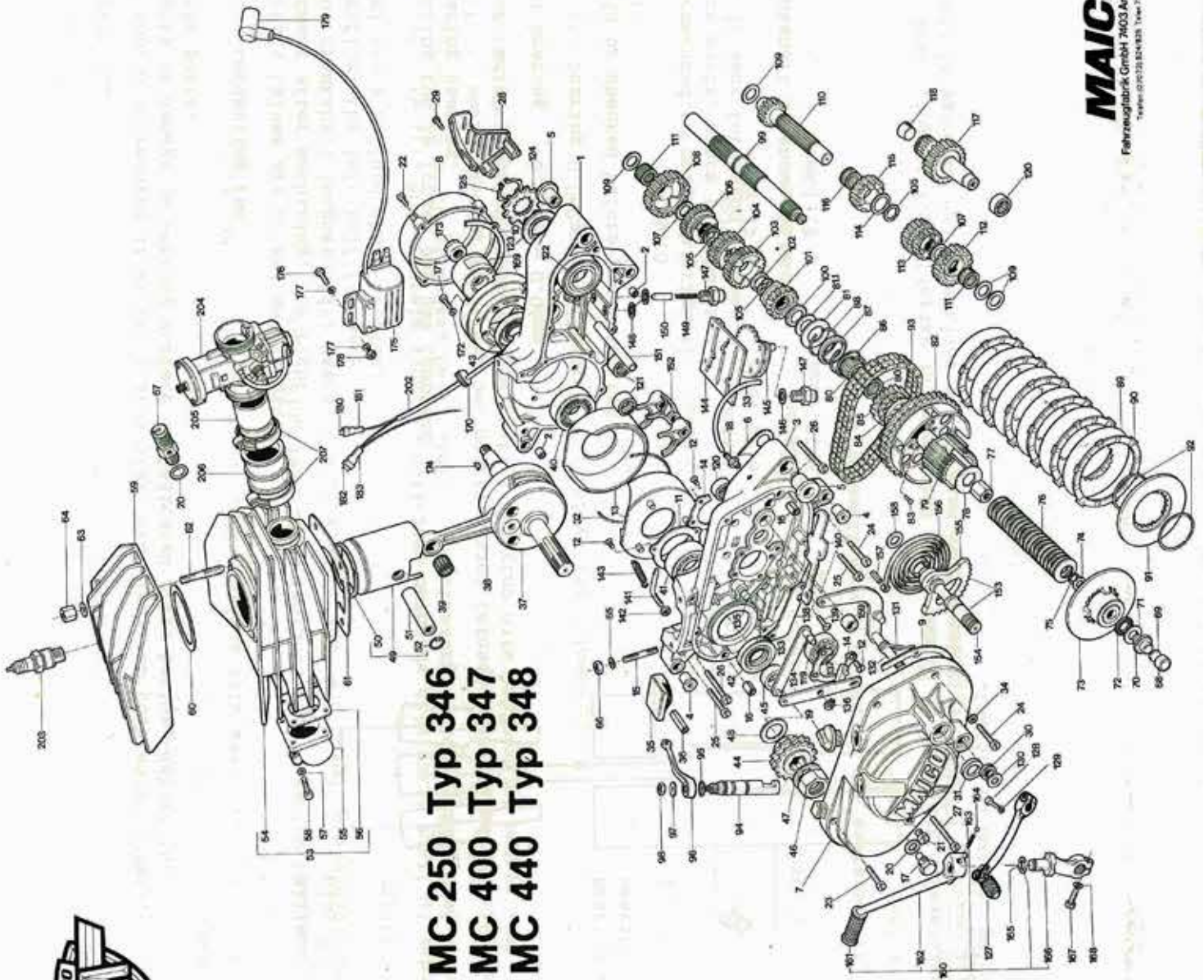

MC 250 Typ 346
MC 400 Typ 347
MC 440 Typ 348



16.1 Parts Description on the Engine

Picture No.	Part No.	Description	MC 250	MC 400	MC 440
			346	347	348
1	1998	Crankcase right hand	1	1	-
2	1982	Crankcase right hand	-	8	1
3	1997	Internal ring	2	2	2
4	1996	Crankcase left hand	1	1	-
5	1979	Crankcase left hand	-	1	1
6	1995	Engine mounting bushes	6	6	6
7	1994	Spacer bush for swing arm	2	2	2
8	1993	Crankcase gasket	1	1	1
9	2140	Crankcase cover	1	1	1
10	1991	Ignition cover	1	1	1
11	1990	Crankcase cover gasket left hand	1	1	1
12	1989	Crankcase cover gasket right hand	1	1	1
13	1988	Main bearing cover plate	1	1	1
14	1795	Counter sunk screw M5 x 8 DIN 965	11	11	11
15	1987	Crankshaft housing	2	2	2
16	1986	MS bearing cover plate	2	2	2
17	1787	Stud screw M8 x 28 DIN 940	4	4	4
18	1831	Tension pin 8 x 10 DIN 7346	2	2	2
19	400	Oil drain plug	1	1	1
20	1985	Breather	1	1	1
21	1984	Oil filling plug	1	1	1
22	410	Spacer ring	2	2	2
23	1526	Cylinder head screw M8 x 10 DIN 84	1	1	1
24	1536	Cylinder head screw M6 x 25 DIN 84	4	4	4
25	1550	Cylinder head screw M6 x 30 DIN 84	3	3	3
26	1538	Cylinder head screw M6 x 35 DIN 84	5	5	5
27	1539	Cylinder head screw M6 x 40 DIN 84	6	6	6
28	1541	Cylinder head screw M6 x 50 DIN 84	2	2	2
29	1542	Cylinder head screw M6 x 55 DIN 84	2	2	2
30	1983	Counter sprocket cover	1	1	1
31	1533	Cylinder head screw M6 x 18 DIN 84	3	3	3
32	1865	Sealing ring AS 12 x 22 x 7 DIN 3760	1	1	1
33	1866	Sealing ring A 18 x 28 x 7	1	1	1
34	1313	String rubber	1	1	1
35	263	Breather tube	5	5	5
36	407	Flat washer A6 x 10 DIN 7603	2	2	2
	2133	Sliding piece	1	1	1
	1835	Tension pin 8 x 36 DIN 1481	1	1	1

Picture No.	Part No.	Description	MC 250 346	MC 400 347	MC 440 348
37	3225	Crankshaft Cpl	1	-	-
	3258	Crankshaft Cpl.	-	1	1
	4131	Crankshaft part-exchange	1	-	-
	4132	Crankshaft part-exchange	-	1	1
38	4163	Connecting rod cpl	1	-	-
	4162	Connecting rod cpl	-	1	1
39	424	Needle bearing red 0-2	1	-	-
		Needle bearing blue 2-4	-	1	1
		Needle bearing white 4-6	-	-	-
40	426	Roller bearing NU 305 C3 DIN 5412	1	-	-
41	693	Ball bearing 3305 C3 DIN 628	1	-	-
42	547	Sealing ring	1	-	-
43	3469	Sealing ring	1	-	-
44	3220	Duplex - Sprocket	1	-	-
	714	Triples sprocket	-	1	1
45	713	Spacer	-	1	1
46	3240	Guide nut on crankshaft	1	-	-
47	3254	Securing plate	1	-	-
48	862	Washer 0.2 thick	1	-	-
	3111	Washer 0.3 thick	When needed	-	-
49	522	Piston std. 66.95	1	-	-
	2059	Piston 1st oversize 67.10	1	-	-
	2060	Piston 2nd oversize 67.25	1	-	-
	2061	Piston 3rd oversize 67.40	1	-	-
	532	Piston std 76.93	-	1	-
	2069	Piston 1st oversize 77.08	-	1	-
	2070	Piston 2nd oversize 77.23	-	1	-
	2071	Piston 3rd oversize 77.38	-	1	-
	2072	Piston 4th oversize 77.53	-	1	-
	2110	Piston std 81.92	-	-	1
	2112	Piston 1st oversize 82.07	-	-	1
	2114	Piston 2nd oversize 82.22	-	-	1
	2116	Piston 3rd oversize 82.37	-	-	1
	2118	Piston 4th oversize 82.52	-	-	1
50	523	Piston ring LD std 67.00	1	-	-
	2064	Piston ring 1st oversize 67.15	1	-	-
	2065	Piston ring 2nd oversize 67.30	1	-	-
	2066	Piston ring 3rd oversize 67.45	1	-	-
	534	Piston ring LD std 77.00	-	1	-

Picture No.	Part No.	Description	MC 250 346	MC 400 347	MC 440 348
	2076	Piston ring 1st oversize 77.15	-	1	-
	2077	Piston ring 2nd oversize 77.30	-	1	-
	2078	Piston ring 3rd oversize 77.45	-	1	-
	2079	Piston ring 4th oversize 77.60	-	1	-
	2111	Piston ring LD std 82.00	-	-	1
	2113	Piston ring 1st oversize 82.15	-	-	1
	2115	Piston ring 2nd oversize 82.30	-	-	1
	2117	Piston ring 3rd oversize 82.45	-	-	1
	2119	Piston ring 4th oversize 82.60	-	-	1
51	535	Piston pin	1	-	-
	537	Piston pin	-	1	1
52	536	Circlip	2	2	2
53	5710	Radial cylinder cpl MC	1	-	-
	5711	Radial cylinder cpl MC	-	1	-
	5713	Radial cylinder cpl MC	-	-	1
	4135	Cylinder part exchange	1	-	-
	4136	Cylinder part exchange	-	1	-
	4137	Cylinder part exchange	-	-	1
54	5038	Cylinder liner	1	-	-
	2159	Cylinder liner	-	1	-
	2163	Cylinder liner	-	-	1
55	5708	Exhaust flange MC	1	1	1
56	298	Gasket for exhaust flange	1	1	1
57	1704	Spring ring B6 DIN 127	4	4	4
58	1635	Socket screw M6 x 25 DIN 912	4	4	4
59	2156	Cylinder head, Radial	1	-	-
	6584	Cylinder head, Radial	-	1	-
	6625	Cylinder head, Radial	-	-	1
60	65	Cylinder head gasket	1	-	-
	720	Cylinder head gasket	-	1	-
	2582	Cylinder head gasket	-	-	1
61	3004	Cylinder head gasket	-	-	1
	721	Cylinder base gasket 0.3 thick	1	1	1
	2237	Cylinder base gasket 0.5 thick	-	-	1
	2967	Cylinder base gasket 0.7 thick	-	-	1
62	2967	Cylinder head stud	5	-	-
	2968	Cylinder head stud	-	5	5
63	1734	Washer B8.4 DIN 125	5	5	5
64	78	Hexagon nut	5	5	5
65	1714	Spring washer B8 DIN 137	4	4	4
66	1670	Hexagon nut M8 DIN 934	4	4	4

Picture No.	Part No.	Description	MC 250 346	MC 400 347	MC 450 348
67	517	Decompressions valve cpl	-	1	1
68	2251	Push pin cap	1	1	1
69	2252	Spacer 1.5 thick	1	1	1
	2253	Spacer 2.0 thick	1	1	1
	2254	Spacer 2.4 thick	1	1	1
	2255	Spacer 2.8 thick	1	1	1
	2256	Spacer 3.2 thick	1	1	1
	2257	Spacer 1.75 thick	1	1	1
70	2889	Push pin	1	1	1
71	1096	Bearing plate	1	1	1
72	1084	Needle cage	1	1	1
73	2886	Guide for clutch disc	1	1	1
74	2890	Washer 10.1 x 18.2 x 0.6	1	1	1
75	1842	Securing ring	1	1	1
76	449	Cup spring	20	20	20
77	448	Guide nut	1	1	1
78	447	Lock plate for guide nut	1	1	1
79	2580	Clutch body	1	1	1
80	736	Needle cage	2	2	2
81	444	Thrust washer	1	1	1
81.1	1884	Spacer washer 17 x 25 x 0.2	When needed		
	3432	Spacer washer 17 x 25 x 0.3	When needed		
82	5590	Clutch housing with kickstarter ratchet wheel	1	1	1
	5594	Clutch housing with kickstarter ratchet wheel	-	1	1
83	1906	Oval head rivet	8	8	8
84	729	Kickstarter ratchet wheel	1	1	1
85	730	Kickstarter pinion	1	1	1
86	731	Ratchet spring	1	1	1
87	732	Spring cup	1	1	1
88	733	Spring ring	1	1	1
89	3390	Inner disc	6	6	6
90	3396	Clutch disc	6	6	6
91	3391	Terminal disc	1	1	1
92	461	Circlip	2	2	2
93	2899	Duplex chain	1	1	1
	2947	Triplex chain	-	1	1
94	462	Clutch spindle	1	1	1
95	464	Sealing ring for clutch spindle	1	1	1
96	2898	Clutch lever	1	1	1

Picture No.	Part No.	Description	MC 250	MC 400	MC 440
97	1732	Washer b6.4 DIN 125	1	1	1
98	1690	Hexagon nut NM6 DIN 980	1	1	1
99	2025	Main shaft	1	1	1
100	2043	M.S shim	1	1	1
101	3441	1st Gear pinion on mainshaft 19 teeth	1	-	-
102	3449	1st Gear pinion on mainshaft 17 teeth	-	1	1
103	3706	Spacer ring	1	1	1
104	3435	4th Gear pinion on mainshaft 26 teeth	1	1	1
105	3434	3rd Gear pinion on mainshaft 24 teeth	1	-	-
106	3967	3rd Gear pinion on mainshaft 23 teeth	-	1	1
107	492	Retainer ring	3	3	3
108	3440	2nd Gear pinion on mainshaft 21 teeth	1	-	-
109	3448	2nd Gear pinion on mainshaft 20 teeth	-	1	1
110	3723	Shim for 1st gear	2	2	2
111	2039	5th. Gear pinion on mainshaft 28 teeth	1	1	1
112	3893	Spacer washer	5	5	5
113	5597	Layshaft (MT 1)	1	1	1
114	913	Needle cage K16 x 21 x 10	2	2	2
115	3438	1st Gear pinion on layshaft 26 teeth	1	-	-
116	3446	1st Gear pinion on layshaft 28 teeth	-	1	1
117	3442	Twin block pinion on layshaft 19/21 teeth	1	1	1
118	3456	Shim for 2nd gear	1	1	1
119	3439	2nd Gear pinion on layshaft 23 teeth	1	-	-
120	3447	2nd Gear pinion on layshaft 24 teeth	-	1	1
121	3757	Needle cage K20 x 24 x 12	1	1	1
122	2037	Drive shaft 28 teeth	1	1	1
123	2038	Plug	1	1	1
124	339	Ball bearing 6303 C3 DIN 625	1	1	1
125	513	Needle bearing HK 1612	2	2	2
	514	Needle bearing BK 1616	2	2	2
	375	Ball bearing 6206 2RS C3 DIN 625	1	1	1
	2044	Spacer ring	1	1	1
	3465	Sprocket 13 teeth	1	1	1
	3720	Sprocket 14 teeth	1	1	1
	1848	Lock ring 29 x 1.5 DIN 471	-	-	-

Picture No.	Part No.	Description	MC 250	MC 400	MC 440
127	6585	Gear change lever	346	347	348
128	1570	Hexagon screw M6 x 25 DIN 933	1	1	1
129	1726	Spring washer A 6,4 DIN 6798	1	1	1
130	2324	Washer 12.1 x 26.2 x 1	1	1	1
131	573	Return spring	1	1	1
132	6586	Gear change crank	1	1	1
133	2336	Pullrod	1	1	1
134	2374	Pullrod pivot arm	1	1	1
135	1903	Pivot pin A8 x 20 DIN 1469	1	1	1
136	1836	Securing ring 8 x 0.8 DIN 471	1	1	1
137	2376	Hooked ratchet sliding arm	1	1	1
138	2375	Guide plate	1	1	1
139	1795	Countersunk screw 5 x 8 DIN 965	2	2	2
140	3326	Hooked ratchet "T"	1	1	1
141	2388	Hook	1	1	1
142	1667	Hexagon nut M6 DIN 934	1	1	1
143	576	Tension spring for hooked ratchet	1	1	1
144	3406	Shifting plate cpl	1	1	1
145	3402	Shifting segment	1	1	1
146	2397	Shim 10.6 x 18.2 x 1	1	1	1
147	2393	Guide screw	2	2	2
148	410	Sealing ring Al4 x 18	2	2	2
149	2395	Tension spring	1	1	1
150	2396	Paul pin	1	1	1
151	2399	Gear selection fork spindle	1	1	1
152	3414	Gear selection fork	3	3	3
153	2566	Kickstarter spindle cpl	1	1	1
154	2559	Kickstarter spindle	1	1	1
155	761	Kickstarter quadrant	1	1	1
156	666	Return spring	1	1	1
157	1828	Tension bush 5 x 26 DIN 1481	1	1	1
158	1753	Shim 12.2 x 30.2 x 0.5	1	1	1
159	3353	Internal ring	1	1	1
160	5035	Kickstarter lever cpl	1	1	1
161	656	Rubber pad	1	1	1
162	5033	Kickstarter lever	1	1	1
163	3867	Compressions spring for kickstarter	1	1	1
164	1874	Ball Ø 7	1	1	1
165	1840	Lock washer RS	1	1	1

Picture No.	Part No.	Description	MC 250 346	MC 400 347	MC 440 348
166	5034	Kickstarter joint	1	1	1
167	1570	Hexagon screw M6 x 25 DIN 933	1	1	1
168	1704	Spring ring B6	1	1	1
169	3598	Motoplatt ignition cpl	1	1	1
170	3530	Rubber sleeve	1	1	1
171	1630	Socket srew M5 x 16 DIN 912	3	3	3
172	1731	Shim B5.3 DIN 125	3	3	3
173	1123	Nut for generator	1	1	1
174	1881	Woodruff key 3 x 3.7 DIN 6888	1	1	1
175	3600	Ignition coil motoplatt	1	1	1
176	1567	Hexagon srew M6 x 16 DIN 933	2	2	2
177	1732	Shim B6.4 DIN 125	4	4	4
178	1690	Hexagon nut NM6 DIN 980	2	2	2
179	3610	Cable plug	1	1	1
180	3576	Connector 6.3 - 1 DIN 46247	1	1	1
181	3596	Connector housing 6.3	1	1	1
182	3595	Connector 9.5 - 6 DIN 46247	1	1	1
183	3597	Connector housing 9.5	1	1	1
202	2607	Wirehousing B \emptyset 3 x 0.4 DIN 40621	x	x	x
203	603	Spark plug Champion N2	1	1	1
204	6349	Carburetor cpl. Bing V54/40/103	1	1	1
-	6355	Carburetor cpl. Bing 54/40/101/II	-	-	-
205	6357	Connecting flange	1	1	1
206	3143	Carburetor manifold	1	1	1
207	683	Clamp	2	2	2
-	2948	Small gasket set consist of 6,9,10,60,61	1	-	-

Picture No.	Part No.	Description	MC 250 346	MC 400 347	MC 450 348
-	2949	Small gasket set consists of 6, 9, 10, 60, 61	-	1	-
-	2950	Small gasket set consists of 6, 9, 10, 60, 61	-	-	1
-	2958	Large gasket set consists of 6, 9, 10, 20, 30, 31, 34, 42, 43, 56, 60, 61, 95, 148	1	-	-
-	2959	Large gasket set consists of 6, 9, 10, 20, 30, 31, 34, 43, 43, 56, 60, 61, 95, 148	1	1	1
-	2960	Large gasket set consists of 6, 9, 10, 20, 30, 31, 34, 42, 43, 56, 60, 61, 95, 148	-	-	1
-	3602	Sealing paste for ignition	1	1	1
-	2948	Small gasket set consist of 6, 9, 10, 60, 61	-	-	-

X= meters



Fahrzeugfabrik GmbH.
7403 Ammerbuch 2 Pfäffingen
Tel.: 07 12 02 / 824 oder 825
Telex: 0729 746

Printed in West-Germany

I

17.0 Explosion chart chassis (I,II)

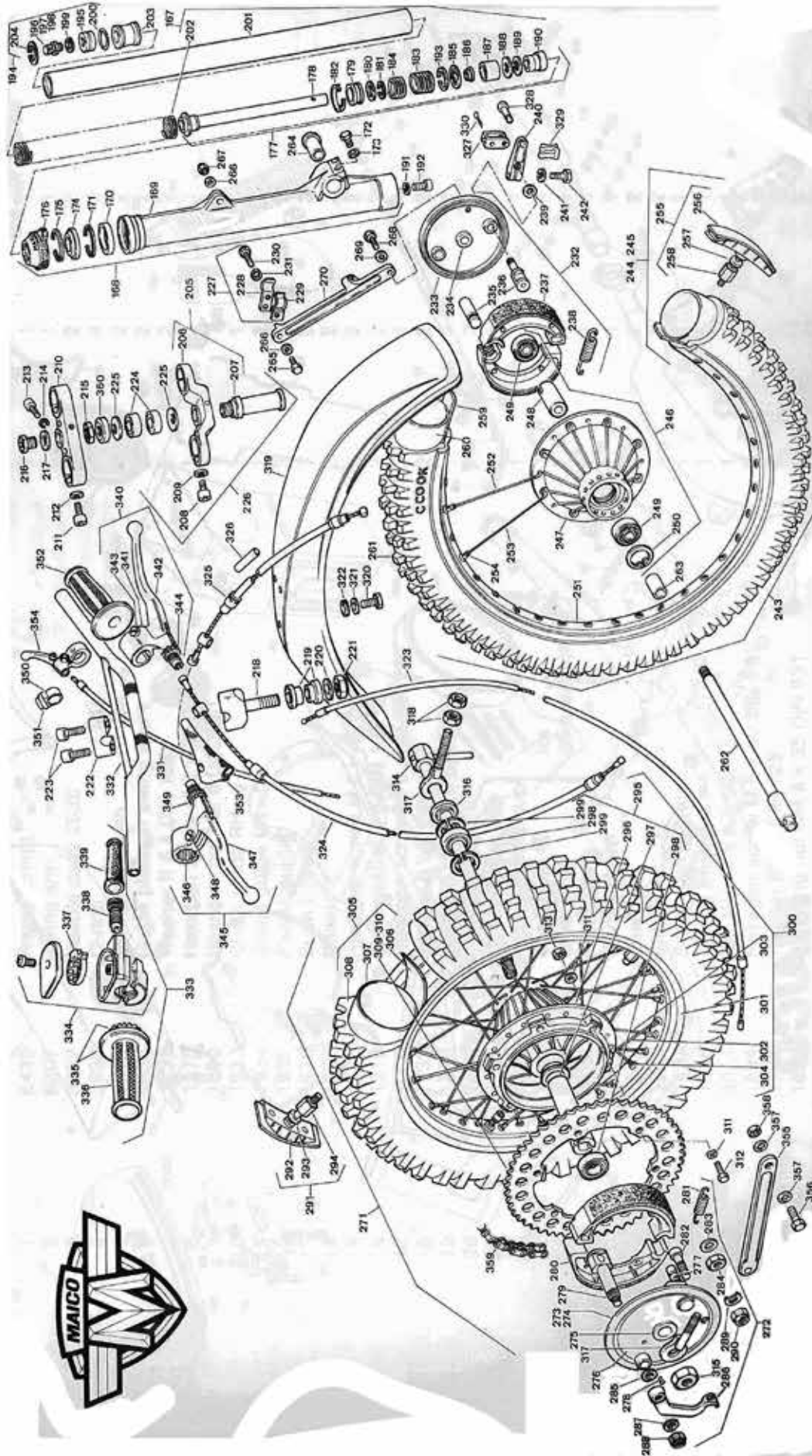

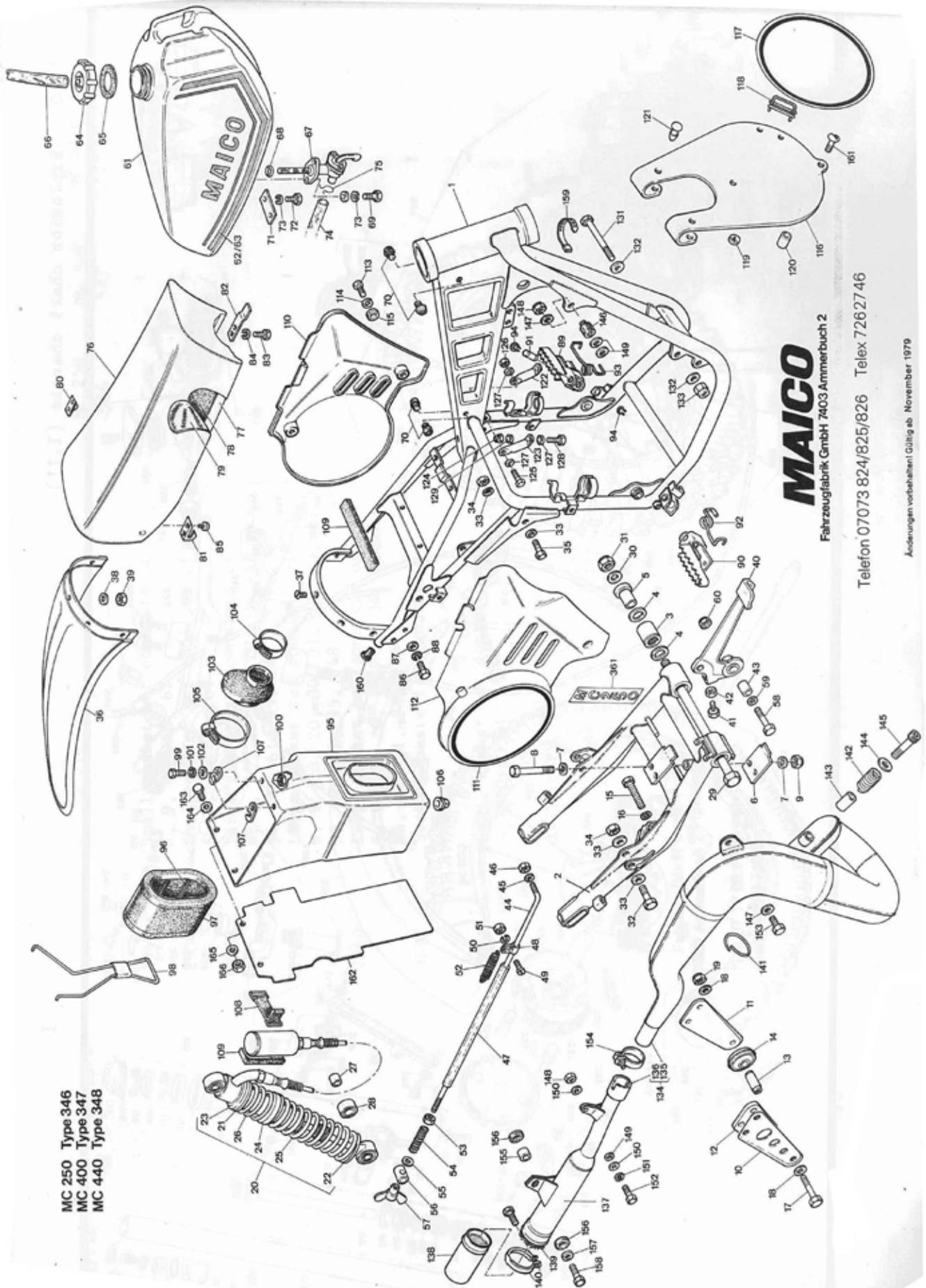

MAICO

Fahrzeugfabrik GmbH 7403 Ammerbuch 2

Telefon 07073 824/825/826 Telex 7262746

Änderungen vorbehalten! Gültig ab November 1979

MC 250 Type 346
 MC 400 Type 347
 MC 440 Type 348

II

17.1 Parts description chassis

Picture No.	Part No.	Description	MC 250 346	MC 400 347	MC 440 348
1	6430	Frame compl.	1	1	1
2	6207	Swing arm	1	1	1
3	3932	Needle cage 2030	2	2	2
4	1930	O-ring	4	4	4
5	1931	Swing arm bush	2	2	2
6	1932	Guide plate on swing arm	2	2	2
7	1732	Washer B 6,4 DIN 125	2	2	2
8	1575	Hexagon screw M 6 x 60 DIN 931	1	1	1
9	1690	Hexagon nut NM 6 DIN 980	1	1	1
10	1933	Chain guide RH	1	1	1
11	1934	Chain guide LH	1	1	1
12	1935	Plastic guide	2	2	2
13	1936	Bush f. roller	3	3	3
14	1937	Roller	2	2	2
15	1580	Hexagon screw M 6 x 45 DIN 933	2	2	2
16	1510	Lock washer B 6 DIN 128	2	2	2
17	1500	Hexagon screw M 6 x 40 DIN 931	1	1	1
18	1732	Washer B 6,4 DIN 125	2	2	2
19	1690	Hexagon nut NM 6 DIN 980	1	1	1
20	6486	Damper compl.	2	2	2
21	1942	Upper spring cup	1	1	1
22	6487	Bottom spring cup	1	1	1
23	1944	Circlip SW 40	1	1	1
24	1945	Guide ring	1	1	1
25	6488	Spring long	1	1	1
26	6491	Spring short	1	1	1
27	1948	Bush	1	1	1
28	1940	Silentbloc	2	2	2
29	3937	Swing arm spindle	1	1	1
30	1718	Spring washer B 14 DIN 137	1	1	1
31	5011	Nut NM 14 x 1,5 DIN 980	1	1	1
32	1594	Hexagon screw M 8 x 40 DIN 931	2	2	2
33	1734	Washer B 8,4 DIN 125	8	8	8
34	1692	Securing nut NM 8 x 35 DIN 931	4	4	4
35	1593	Hexagon screw M 8 x 35 DIN 931	2	2	2
36	6496	Rear fender	1	1	1
37	1791	Countersunk screw M 5 x 12	5	5	5
38	1741	Washer B 5,3 DIN 9021	5	5	5
39	1689	Hexagon nut NM 5 DIN 980	5	5	5
40	6502	Brake lever	1	1	1

for 1 damper unit

Picture No.	Part No.	Description	Quantity Typ		
			MC 250 346	MC 400 347	MC 440 348
41	1570	Hexagon screw M 6 x 25 DIN 933	1	1	1
42	1667	Hexagon nut M 6 DIN 934	1	1	1
43	6505	Bushing f. brake lever	1	1	1
44	1977	Rear brake rod	1	1	1
45	1732	Washer B 6,4 DIN 125	1	1	1
46	1690	Hexagon nut M 6 DIN 980	1	1	1
47	406	Hose	x	x	x
48	237	Clamp	1	1	1
49	1527	Cyl. head screw M 4 x 10 DIN 84	1	1	1
50	1702	Spring ring B 4 DIN 127	1	1	1
51	1665	Hexagon nut M 4 DIN 934	1	1	1
52	236	Extension spring	1	1	1
53	1667	Hexagon nut M 6 DIN 934	1	1	1
54	242	Compression spring	1	1	1
55	1732	Washer B 6,4 DIN 125	1	1	1
56	244	Nipple holder	1	1	1
57	243	Wing nut	1	1	1
58	1597	Hexagon nut M 8 x 55 DIN 931	1	1	1
59	1743	Washer B 8,4 DIN 125	1	1	1
60	1692	Securing nut	1	1	1
61	6507	Tank with decal	1	1	1
62	6512	Tank decal left	1	1	1
63	6513	Tank decal right	1	1	1
64	6515	Gas Tap compl.	1	1	1
65	6516	Sealing ring	1	1	1
66	6517	Vent hose	1	1	1
67	6509	Pet cock	1	1	1
68	6510	O-ring	1	1	1
69	1525	Hexagon screw M 6 x 14 DIN 933	2	2	2
70	3528	Rubber stop	4	4	4
71	6511	Holding plate f. tank	1	1	1
72	1525	Hexagon screw M 6 x 14 DIN 933	2	2	2
73	1510	Lock washer	4	4	4
74	406	Gas hose	1	1	1
75	2832	Hose clip	2	2	2
76	6525	Seat compl.	1	1	1
77	5193	Seat base	1	1	1
78	6526	Seat foam	1	1	1
79	6527	Seat cover	1	1	1
80	6521	Seat mountg. hook left	1	1	1

Picture No.	Part No.	Description	Quantity Typ		
			MC 250 346	MC 400 347	MC 440 348
81	6522	Seat mountg. hook right	1	1	1
82	286	Clamp holder f. seat	1	1	1
83	1567	Hexagon screw M 6 x 16 DIN 933	2	2	2
84	1704	Spring washer B 6 DIN 127	2	2	2
85	6524	Countersunk metal screw	4	4	4
86	1587	Hexagon screw M 8 x 16 DIN 933	2	2	2
87	1759	Washer B 8,4 DIN 9021	2	2	2
88	1511	Spring washer	2	2	2
89	6533	Foot peg left compl.	1	1	1
90	6535	Foot peg right compl.	1	1	1
91	6536	Foot peg axle	2	2	2
92	6537	Foot peg spring right	1	1	1
93	6538	Foot peg spring left	1	1	1
94	6539	Circlip 10 x 1 DIN 471	4	4	4
95	6546	Air box	1	1	1
96	6544	Air filter cage	1	1	1
97	6545	Air filter foam	1	1	1
98	6540	Holding wire	1	1	1
99	1567	Hexagon screw M 6 x 16 DIN 933	5	5	5
100	1690	Hexagon nut NM 6 DIN 980	5	5	5
101	1732	Washer B 6,4 DIN 125	5	5	5
102	1750	Washer B 6,4 DIN 9021	5	5	5
103	6551	Intake Manifold	1	1	1
104	683	Clamp Ø 40-60	1	1	1
105	348	Clamp Ø 78	1	1	1
106	6552	Plug f. air box	1	1	1
107	6553	Hook	2	2	2
108	6489	Rubber band	2	2	2
109	5204	Sealing rubber	x	x	x
110	6561	Side panel left	1	1	1
111	4153	Green no plate decal	2	2	2
	4152	yellow no plate decal	-	-	-
112	6563	Side panel right	1	1	1
113	5050	Screw M 6 x 16 DIN 7985	4	4	4
114	1750	Washer B 6,4 DIN 9021	4	4	4
115	2708	Rubber washer	4	4	4
116	6555	Front no panel	1	1	1
117	6252	No. plate decal green front	1	1	1
	6261	No. plate decal yellow front	-	-	-
118	6247	Cable guide compl.	1	1	1

Picture No.	Part No.	Description	Quantity Typ		
			MC 250 346	MC 400 347	MC 440 348
119	6265	Spring nut	2	2	2
120	3094	Sliding roller	2	2	2
121	6267	Clip	2	2	2
122	6557	Cyl. head stay left	1	-	-
-	6597	Cyl. head stay left	1	1	1
123	6558	Cyl. head stay right	1	-	-
-	6598	Cyl. head stay right	1	1	1
124	78	Hexagon nut M 8 long	2	2	2
125	1591	Hexagon nut M 8 x 25 DIN 933	1	1	1
126	1692	Securing nut NM 8 DIN 980	1	1	1
127	1734	Washer B 8,4 DIN 125	6	6	6
128	1592	Hexagon screw M 8 x 30 DIN 933	2	2	2
129	1511	Spring ring B 8 DIN 128	2	2	2
130	6254	set motormount bolts consisting of Pos. 131, 132, 133	1	1	1
131	1610	Hexagon screw M 8 x 120 DIN 931	2	2	2
132	1734	Washer B 8,4 DIN 125	4	4	4
133	1700	Nut M 8 DIN 980	2	2	2
134	6594	Exhaust pipe cpl.	1	-	-
-	6618	Exhaust pipe cpl.	1	1	1
135	6574	Expansion chamber	1	-	-
-	6609	Expansion chamber	1	1	1
136	6559	Silencer cpl.	1	-	-
-	6616	Silencer cpl.	1	1	1
137	6583	Silencer housing	1	-	-
-	6615	Silencer housing	1	1	1
138	6410	Silencer end piece cpl.	1	-	-
139	6420	Exhaust packing	1	1	1
140	6421	Clamp for silencer	1	1	1
141	896	Asbestos cord	X	X	X
142	6275	Spring for exhaust	1	1	1
143	6276	Sleeve for exhaust spring	1	1	1
144	1750	Washer 6,4 DIN 9021	1	1	1
145	1523	Cyl. head screw M 6 x 70 DIN 912	1	1	1
146	1166	Silent bloc f. exhaust	1	1	1
147	1732	Washer B 6,4 DIN 125	2	2	2
148	1690	Nut M 6 DIN 980	2	2	2
149	5430	Asbestos washer	4	4	4
150	1750	Washer 6,4 DIN 9021	2	2	2
151	1510	Spring ring B 6 DIN 128	1	1	1

Picture No.	Part No.	Description	Quantity Typ			
			MC 250 346	MC 400 347	MC 440 348	
152	1525	Hexagon screw M 6 x 14 DIN 933	1	1	1	
153	1567	Hexagon screw M 6 x 16 DIN 933	1	1	1	
154	5429	Clamp	1	1	1	
155	5453	Bush f. exhaust mount	1	1	1	
156	5345	Rubber washer	2	2	2	
157	1759	Washer 8,4 DIN 9021	1	1	1	
158	1591	Hexagon screw M 8 x 25 DIN 933	1	1	1	
159	325	Rubber cable clip	8	8	8	
160	6565	Rubber plug	2	2	2	
161	6253	Plastic screw	2	2	2	
162	6564	Splash guard	1	1	1	
163	1567	Hexagon screw M 6 x 16 DIN 933	2	2	2	
164	1750	Washer 6,4 DIN 9021	2	2	2	
165	1732	Washer B 6,4 DIN 125	2	2	2	
166	1690	Nut NM DIN 980	2	2	2	
167	6465	Fork leg cpl.	2	2	2	
168	6438	Fork slider cpl.	2	2	2	
169	6435	Fork slider	2	2	2	
170	6436	Guide bush	2	2	2	
171	6437	Circlip SB 46	2	2	2	
172	1571	Hexagon nut M 6 x 30 DIN 931	4	4	4	
173	1510	Spring ring B 6 DIN 128	4	4	4	
174	6439	Seal	2	2	2	
175	6440	Circlip SB 55 x 1,5	2	2	2	
176	6441	Wiper	2	2	2	
177	6451	Damper cpl.	2	2	2	
178	6442	Damper tube	2	2	2	
179	6447	Damper piston	2	2	2	
180	6448	Washer 23,9 x 28,2 x 0,9	2	2	2	
181	6449	Retaining ring SW 24	2	2	2	
182	6450	Piston ring	2	2	2	
183	6452	Stop spring soft	2	2	2	
184	6460	Stop spring hard	2	2	2	
185	6453	Valve seat	2	2	2	
186	6454	Valve	2	2	2	
187	6455	Damper insert	2	2	2	
188	6456	Washer 29,9 x 36,7 x 0,2	2	2	2	
189	6457	Securing ring 37 x 1,5 DIN 472	2	2	2	
190	6458	Bush f. damper	2	2	2	
191	6459	Seal A 10 x 15 DIN 7603	2	2	2	

Picture No.	Part No.	Description	Quantity Typ	
			MC 250 346	MC 400 347
192	1655	Socket screw M 10 x 25 DIN 6912	2	2
193	6461	Circlip SB 37	2	2
194	6462	Fork cap cpl.	2	2
195	6463	Fork cap	2	2
196	2184	Valve cpl.	2	2
197	2186	Valve insert	2	2
198	2187	Valve cap	2	2
199	277	Seal A 8 x 11,5 DIN 7603	2	2
200	6464	O-ring 29,74 x 3,53	2	2
201	6466	Fork tube	2	2
202	6467	Fork spring	2	2
203	6468	Spacer tube	2	2
204	6457	Circlip 37 x 1,5 DIN 472	2	2
205	6469	Lower cross head cpl.	1	1
206	6470	Lower cross head	1	1
207	6471	Steering tube	1	1
208	3270	Socket screw M 10 x 40 DIN 6912	2	2
209	1512	Spring ring	2	2
210	6473	Upper cross head	1	1
211	3270	Socket screw M 10 x 40 DIN 6912	2	2
212	1512	Spring ring B 10 DIN 128	2	2
213	1648	Socket screw M 8 x 40 DIN 912	1	1
214	1511	Spring ring B 8 DIN 128	1	1
215	6474	Steering head nut	1	1
216	6475	Screw plug	1	1
217	6476	Washer B 23 DIN 125	1	1
218	6477	Handle bar clamp low cpl.	2	2
219	15	Rubber buffer	4	4
220	1735	Washer B 10,5 DIN 125	2	2
221	1693	Nut M 10 DIN 980	2	2
222	6478	Handle bar clamp upper	2	2
223	1628	Socket screw M 8 x 25 DIN 6912	4	4
224	3297	Tapered Roller bearing	2	2
225	3296	Nilos-Ring	2	2
226	6472	Fork cpl.	1	1
227	6257	Cable holder cpl.	1	1
228	6258	Cable clamp	1	1
229	6255	Cable clamp	1	1
230	1565	Hexagon screw M 6 x 12 DIN 933	1	1
231	1510	Spring ring B 6 DIN 128	1	1

Picture No.	Part No.	Description	Quantity Typ		
			MC 250 346	MC 400 347	MC 440 348
232	6144	Front brake plate cpl.	1	1	1
233	2236	Front brake plate w. bush	1	1	1
234	2238	Bushing	1	1	1
235	2418	Pivot bolt	1	1	1
236	2419	Brake toggle	1	1	1
237	1322	Brake shoe	2	2	2
238	6148	Spring for brake shoe	2	2	2
239	187	Rubber washer	1	1	1
240	6145	Brake arm front	1	1	1
241	1510	Spring washer B 6 DIN 128	1	1	1
242	1570	Hexagon screw M 6 x 25 DIN 933	1	1	1
243	6146	Front wheel cpl.	1	1	1
244	2240	Front wheel w. tire	1	1	1
245	2235	Front wheel	1	1	1
246	2234	Front hub cpl.	1	1	1
247	2233	Front hub	1	1	1
248	2428	Spacer tube	1	1	1
249	2427	Ball bearing 6202	2	2	2
250	1853	Lock ring 35 x 1,5 DIN 472	1	1	1
251	3497	Akront rim	1	1	1
252	2432	Front spoke right	18	18	18
253	2433	Front spoke left	18	18	18
254	2242	Nipple	36	36	36
255	168	Tire holder front	1	1	1
256	2568	Tire holder plate cpl.	1	1	1
257	1734	Washer B 8,4 DIN 125	1	1	1
258	289	Nut for tire holder	1	1	1
259	2001	Tire flap 21"	1	1	1
260	2002	Tube 3.00-21"	1	1	1
261	2003	Tire 3.00-21"	1	1	1
262	2247	Front axle cpl.	1	1	1
263	2250	Spacer bush	1	1	1
264	2430	Threaded bush	1	1	1
265	1594	Hexagon screw M 8 x 40 DIN 931	1	1	1
266	1734	Washer B 8,4 DIN 125	2	2	2
267	1692	Nut NM 8 DIN 980	1	1	1
268	1589	Hexagon screw M 8 x 20 DIN 933	1	1	1
269	1714	Spring washer M 8 x 20 DIN 933	1	1	1
270	6147	Brake stay	1	1	1
271	6290	Rear wheel cpl.	1	1	1

Picture No.	Part No.	Description	Quantity Typ		
			MC 250 346	MC 400 347	MC 440 348
272	3186	Brake plate cpl.	1	1	1
273	3045	Brake plate w. pressed parts	1	1	1
274	3187	Brake plate only	1	1	1
275	183	Spacer bush	2	2	2
276	3188	Cover plate	1	1	1
277	3189	Pivot bolt	1	1	1
278	1901	Oval head nail 3 x 8 DIN 1476	1	1	1
279	151	Brake toggle cpl.	1	1	1
280	188	Brake shoe	2	2	2
281	1323	Tension spring	2	2	2
282	3270	Socket screw M 10 x 40 DIN 6912	1	1	1
283	1715	Spring washer B 10 DIN 137	1	1	1
284	1674	Nut M 10 DIN 934	1	1	1
285	187	Rubber washer	1	1	1
286	3190	Rear brake lever	1	1	1
287	1734	Washer B 8,4 DIN 125	1	1	1
288	1692	Securing nut NM 8 DIN 980	1	1	1
289	1735	Washer B 10,5 DIN 125	1	1	1
290	1693	Hexagon nut NM 10 DIN 980	1	1	1
291	2434	Tire holder rear compl.	1	1	1
292	2567	Tire holder plate	1	1	1
293	1734	Washer B 8,4 DIN 125	1	1	1
294	289	Nut for Tire holder	1	1	1
295	3875	Rear hub compl.	1	1	1
296	3868	Rear hub	1	1	1
297	3872	Spacer tube compl.	1	1	1
298	205	Ball bearing 6303 2 RS C 3	2	2	2
299	1852	Spring ring 47 x 1,75	2	2	2
300	3876	Rear wheel	1	1	1
301	2405	Rim	1	1	1
302	2406	Spoke rear, right	18	18	18
303	2407	Spoke rear, left	18	18	18
304	2408	Nipple	36	36	36
305	3343	Rear wheel + 56 T + tire	1	1	1
306	2005	Rim strap 18"	1	1	1
307	2015	Tube 4,50 x 18	1	1	1
308	2008	Tire 4,50 x 18	1	1	1
309	3227	Sprocket 56 T	1	1	1
310	2200	Sprocket 54 T	1	1	1
311	1713	Spring washer B 7 DIN 137	16	16	16

Picture No.	Part No.	Description	Quantity Typ			
			MC 250 346	MC 400 347	MC 440 348	
312	3280	Hexagon screw M 7 x 40 DIN 933	6	6	6	
313	1691	Hexagon nut NM 7 DIN 980	6	6	6	
314	3277	Rear axle cpl.	1	1	1	
315	1709	Hexagon nut NM 16 x 1,5 DIN 980	1	1	1	
316	3880	Spacer ring	1	1	1	
317	6287	Chain adjuster	2	2	2	
318	1670	Nut M 8 DIN 934	4	4	4	
319	6493	Front fender	1	1	1	
320	1569	Hexagon screw M 6 x 20 DIN 933	4	4	4	
321	1750	Washer 6,4 DIN 9021	4	4	4	
322	2708	Rubber washer	4	4	4	
323	2456	Throttle cable	1	1	1	
324	6150	Clutch cable	1	1	1	
325	6530	Brake cable	1	1	1	
326	2275	Hose B 8 x 0,7 DIN 40 621	X	X	X	
327	6151	Cable holder	1	1	1	
328	6152	Bolt	1	1	1	
329	6153	Clip for bolt	1	1	1	
330	1857	Split pin 3,2 x 25 DIN 94	1	1	1	
331	315	Decompressor cable	-	1	1	
332	6498	Handle bar, low	1	1	1	
333	6280	Throttle grip cpl.	1	1	1	
334	6283	Throttle housing cpl.	1	1	1	
335	6282	Tube with grip	1	1	1	
336	2148	Rubber grip	1	1	1	
337	6284	Cam	1	1	1	
338	2211	Adjusting screw	1	1	1	
339	2212	Rubber cap	1	1	1	
340	2215	Hand clutch lever cpl.	1	1	1	
341	2213	Hinge for clutch lever	1	1	1	
342	2216	Clutch lever blade	1	1	1	
343	133	Lever screw	1	1	1	
344	212	Adj. nut	1	1	1	
345	2218	Hand brake lever cpl.	1	1	1	
346	2217	Hinge for brake lever	1	1	1	
347	2219	hand brake lever	1	1	1	
348	133	Lever screw w. nut	1	1	1	
349	212	Adj. nut	1	1	1	
350	2220	Kill button	1	1	1	
351	2221	Rubber cap	1	1	1	

Picture No.	Part No.	Description	MC 250 346	Quantity	MC 400 347	MC 440 348
352	2512	Rubber grip	1	1	1	1
353	3166	Lever cover	2	2	2	2
354	148	Lever f. decompressor cpl.	-	1	1	1
355	1978	Rear brake plate	1	1	1	1
356	1591	Hexagon screw M 8 x 25 DIN 933	1	1	1	1
357	1734	Washer B 8,4 DIN 125	2	2	2	2
358	1692	Nut NM 8 DIN 980	1	1	1	1
359	2281	Chain	1	1	1	1
360	6480	Cover tray	1	1	1	1
361	6532	Sticker MC 250	1	-	-	-
-	6601	Sticker MC 400	-	1	-	-
-	6623	Sticker MC 440	-	-	1	1

18.0 Explosion chart carburetor

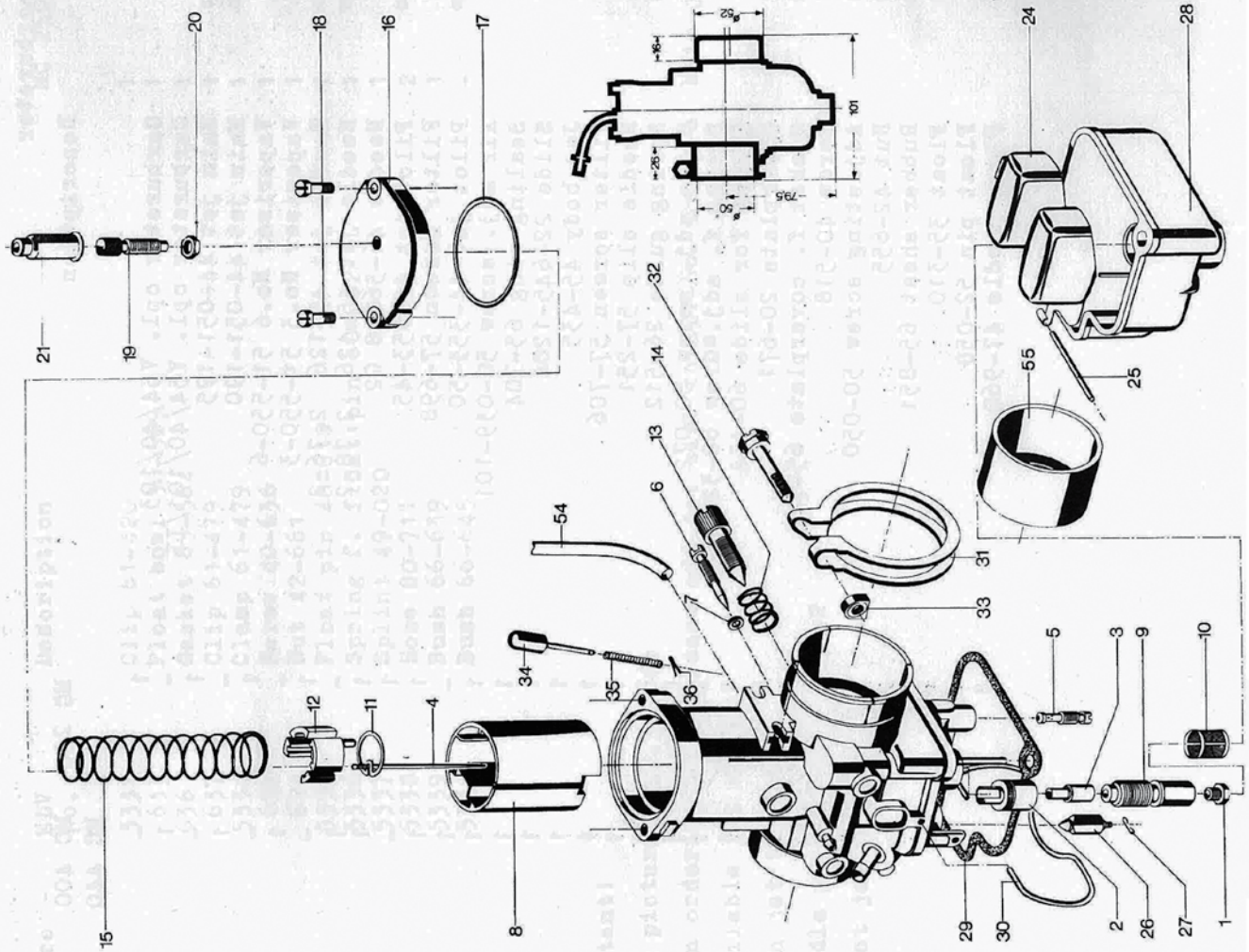

18.1 Spare parts carburetor

Picture No.	EDV No.	Description	MC 250	MC 400	MC 440
-	2512	Rubber grip	1	1	1
-	3166	Lever cover	-	-	-
-	148	Carburetor cpl. V54/40/103	1	1	1
-	1878	Carburetor cpl. V54/40/101/II	1	1	1
1	624*	Main jet 44-051-195	1	1	1
-	624*	Main jet 44-051-190	1	1	1
2	2891	Vaporizer No.6 51-550-6	1	1	1
-	3178	Vaporizer No.3 51-550-3	1	1	1
-	5302*	Needle jet 45-126 2,76-2	1	1	1
3	5302*	Needle jet 45-126 2,78-2	1	1	1
-	6351	Needle 46-360-8 G2	1	1	1
4	626*	Pilot jet 44-353-45	1	1	1
5	5343	Filter screen 57-698	1	1	1
-	626*	Pilot jet 44-353-50	1	1	1
-	5325	Air adj. screw 50-039-101	1	1	1
6	5326	Sealing ring 65-704	1	1	1
7	5327	Slide 22-645-1204	1	1	1
8	5328	Jet body 45-435	1	1	1
9	5329	Filter screen 57-706	1	1	1
10	643	Needle clip 57-251	1	1	1
11	5330	Spring guide 26-512	1	1	1
12	631	Slide adj. screw 50-072	1	1	1
13	632	Spring f. adj. screw 60-322	1	1	1
14	5331	Spring for slide 60-434	1	1	1
15	5332	Coverplate 20-671	1	1	1
16	650	Gasket f. coverplate 65-745	1	1	1
17	647	Screw 40-518	1	2	1
18	648	Adjusting screw 50-050	1	1	1
19	649	Nut 42-655	1	1	1
20	651	Rubber sheat 65-851	1	1	1
21	638	Float 35-310	1	1	1
24	640	Float pin 52-058	1	1	1
25	5333	Float needle 47-968	1	1	1
26			1	1	1

Picture No.	EDV No.	Description	MC 250	MC 400	MC 440
27	3331	Clip 61-420	1	1	1
28	633	Float bowl 30-569	1	1	1
29	636	Gasket 65-584	1	1	1
30	637	Clip 61-479	1	1	1
31	5334	Clamp 61-479	1	1	1
32	620	Screw 40-636	1	1	1
33	621	Nut 42-661	1	1	1
34	5335	Float pin 48-830	1	1	1
35	5336	Spring f. float pin 60-062	1	1	1
36	5337	Splint 49-020	1	1	1
54	5338	Hose 80-711	2	2	2
55	5339	Bush 66-639	1	1	1
-	5342	Bush 66-645	-	-	1

Important!

* See picture No.1,3 and5

When ordering jets, please add jet size to EDV-No. Example: Main jet 624-190.

Available jet sizes:

Main jet 180-205

Needle jet 274-2 - 282-2

Pilot jet 30-82

19.0 Measurements of motorcycle

MC 250 MC 400 MC 440
 Typ 346 Typ 347 Typ 348
 Hauptabmessungen

