

PARTS LIST



“DELUXE MODEL” AND SIDECARS



Excelsior Motor Mfg. and Supply Co.
3701 Cortland Street
CHICAGO ILLINOIS

NOTICE

Several pieces of equipment for the Henderson, such as the magneto, generator, battery, etc., are made by manufacturers other than ourselves. The manufacturers of these parts are anxious that all users shall obtain satisfactory service and will welcome a chance to help you in case you should experience any trouble with their products. Some of these pieces of equipment require complicated and highly specialized manufacturing process, so that service can best be given by the manufacturers themselves. For service, repairs, adjustments, parts or information pertaining to any of these pieces of equipment, please communicate direct with the manufacturers whose names are given below:

MAGNETO	SIMMS MAGNETO CO., East Orange, N. J.
GENERATOR	SPLITDORF ELECTRICAL CO., 392 High St., Newark, N. J.
BATTERY	WICO ELECTRIC CO., Springfield, Mass.
CARBURETOR	ZENITH-DETROIT CORPORATION, Foot of Hart Ave., Detroit, Mich
HORN	REMY ELECTRICAL DIVISION, General Motors Co., Klaxon Branch, Newark, N. J.
HEADLAMP	C. M. HALL LAMP CO., Kenosha, Wis.
AMMETER	WESTON ELECTRICAL INSTRUMENT CO., Waverly Park, Newark, N. J.
TAIL LAMP	CORCORAN-VICTOR CO., Cincinnati, Ohio

EXPLANATORY

FRAME

When ordering a frame, be sure to state whether the new low frame or the old high frame is required. The gasoline tank and other parts of the new low frame model WILL NOT FIT the old high frame model.

REAR MUD GUARDS, GASO- LINE TANKS BATTERYBOXES REAR STANDS CHAIN GUARDS

All of these parts of the new low frame model will not fit the old high frame model. Therefore, when ordering any of these parts you can prevent mistakes by stating whether they are wanted for the new low frame or old high frame models.

HIGH LIFT CAMSHAFT

To install the new high lift camshaft in the old models it is necessary to make some alterations to the crankcase as shown on Service Bulletin No. 7. Also, the new style tappets and guides must be used, or the old ones must be altered in accordance with the Service Bulletin.

NEW GEAR SHIFTER LEVER AND SHIFTER SHAFT

In the latest gear shifting mechanism, the shifter lever slides on a stationary shaft and is held in the different shift positions by means of a new spring and ball lock. All adjustments are made from the outside of the transmission case. To install these new shifter parts some crankcase alterations are necessary which are shown on Service Bulletin No. 8.

BAFFLE PLATES

The latest baffle plates which baffle the cylinder openings as well as the tappets, are shown on Service Bulletin No. 2 which gives instructions for installation in old models.

CLUTCH RELEASE SHAFT

The clutch release shaft has been strengthened by increasing the diameter from 9/16" to 19/32". To install the latest shaft it will be necessary to drill or ream the clutch release fork to take the new 19/32" shaft and to enlarge the hole in the crankcase for the end of the shaft accordingly.

ENGINE SPROCKETS

The new Hendersons are equipped with engine sprockets having a single keyway for a special No. 9 Woodruff key. Sprockets for the old models had four keyways for No. 6 keys. When ordering engine sprockets or spline shafts be sure to specify whether they are wanted with ONE or FOUR keyways.

TIMKEN HUBS

Many of the parts for front and rear Timken hubs are interchangeable, as you will notice from the parts list. Timken bearings can be installed in old model ball bearing rear hubs by means of our Timken Conversion Set, in which a pair of special adapter cups are used in the ends of the old hub replacing the old ball cups. For the front, it is necessary to build up a new wheel using one of the new Henderson Timken Hubs. **BE SURE TO PLACE FRONT WHEEL IN THE FRAME WITH THE ADJUSTING CONE ON THE LEFT SIDE. THIS ADJUSTING CONE HAS A RIGHT HAND THREAD AND WHEN PLACED ON THE LEFT SIDE OF THE FORK IF IT SHOULD EVER WORK LOOSE, REVOLUTION OF THE WHEEL WILL NOT TIGHTEN UP AND PINCH THE BEARINGS.**

VALVOLINE OIL

A great proportion of the motor troubles are caused by inferior oil. We have been using and recommending Valvoline Oil for several years. We know that riders and dealers who use Valvoline Oil will have an absolute minimum amount of motor trouble. For your own protection insist upon Valvoline Oil which can be purchased from the Valvoline Oil Co., 89 Broadway, New York City, or 105 North Clinton St., Chicago, or from any of their branches.

UNLESS YOU HAVE AN AC- COUNT WITH US

Unless you have been buying parts from us and have an established account, enclose money order or stamps to cover parts and transportation. We cannot open small accounts with individuals, so cash with your order is necessary. Unless you do send a remittance with your order, shipment will be delayed.

ALL PRICES ARE SUBJECT TO CHANGE WITHOUT NOTICE

HENDERSON
"DE LUXE MODEL"
AND SIDECARS
PARTS LIST



Excelsior Motor Mfg. & Supply Co.

3701 Cortland Street

CHICAGO

: : :

ILLINOIS

Henderson "DeLuxe Model" Parts List

Superseding All Previous Lists

073042

To prevent mistakes and to avoid delay in parts shipments always specify the number of your motor and the model of your machine. Also give the photo number and parts number as well as the names of the parts as listed in this catalog. This will enable our Parts Department to fill your orders accurately and promptly.

Remember, if you do not tell us just what you require and give us the parts numbers we have no way of knowing what you need.

Orders for parts except from our regular dealers must always be accompanied by money orders or stamps for full payment. We cannot open accounts for small amounts with individual owners so cash with order is necessary. Be sure to include money for transportation charges on the parts you are ordering.

If you desire to write about some other matter when ordering parts, fill out your parts order on a separate sheet from the letter. In other words, do not order parts on the same sheet of paper on which you are writing your letter. This will enable us to give better attention to the parts order and to your letter. Be sure to put your name, address and full shipping instructions on all orders.

Remember that by making your orders clear and easy to understand you will enable us to take care of your requirements quickly and correctly. If we do not understand what you want, we may ship you the wrong parts or we may have to hold up your order and write to you for further information. For instance, if you wanted to order an oil filler extension, this should be specified: **One No. 62 - K1116 Oil Filler Extension for 1923 Henderson Motor, No. 9573.**

A telegraphic code consisting of five letters words is given for economizing when ordering parts by wire. When telegraphing rush orders, be extremely careful to use the correct code words for the parts desired. Thus, to order an oil filler extension for a Henderson DeLuxe model, simply wire us "**One WODDA**" which is the code word for this part.

When returning parts to us for repairs or replacement a letter should be sent to us at the same time giving full information and detailed instructions as to what is desired. Be sure that the parts are plainly tagged with your name and address and that transportation charges are prepaid.

When ordering parts place yourselves in our position for the moment. Read over your order and consider whether or not you would understand just what was wanted if you were filling orders in our Parts Department.

Prices are subject to change without notice.

EXCELSIOR MOTOR MFG. & SUPPLY CO.

3701 Cortland St.

Chicago, Illinois

HENDERSON "DELUXE MODEL"

MOTOR PARTS—(Plates I-II)

Photo No.	Code	Parts No.	NAME	Price
	WOBUM	K-1000	Crank Case, Upper Half Only	\$65.00
	WOBUP	K-1100	Crank Case, Lower Half Only	26.00
1	WOBUS	K-195	Four Ring Alloy Piston, Complete	6.25
	WOCAL	K-1910	Four Ring Alloy Piston, Only, Standard	5.25
	WOCAL	K-1910-A	Four Ring Alloy Piston, Only, .010" Oversize	5.25
	WOCAN	K-1910-B	Four Ring Alloy Piston, Only, .020" Oversize	5.25
2	WOCAR	K-1950	Piston Wrist Pin, Standard	.45
	WOCAT	K-1950-A	Piston Wrist Pin, .005" Oversize	.45
	WOCAY	K-1950-B	Piston Wrist Pin, .010" Oversize	.45
3	WOCAX	K-1912	Piston Ring for Four Ring Piston, Standard, Left-hand Cut	.25
4	WOCBA	K-1912	Piston Ring for Four Ring Piston, Standard, Right-hand Cut	.25
	WOCBI	K-1912-A	Piston Ring for Four Ring Piston, Standard, .020" Oversize	.25
	WOCBY	K-191	Cast Iron Piston, Complete with Rings	1.00
	WOCBA	K-1900	Cast Iron Piston, Only	2.00
	WOCBI	K-1906	Cast Iron Piston Rings, Standard	.25
	WOCDE	K-1905	Cast Iron Piston, Only, .020" Oversize	2.10
	WOCDO	K-1908	Cast Iron Piston Ring, .020" Oversize	.25
	WOCED	K-195	Alloy Piston, Two Rings, Complete with Rings	6.25
	WOCED	K-1910	Alloy Piston, Only (Two Ring Type)	5.75
	WOCED	K-1914	Alloy Piston, Only (Two Ring Type) .010" Oversize	5.75
	WOCED	K-1915	Alloy Piston, Only (Two Ring Type) .020" Oversize	5.75
	WOCEL	K-1912	1/4" Piston Rings for Same, Standard	.25
	WOCEM	K-1912-A	1/4" Piston Rings for Same, .020" Oversize	.25
5	WOCFP	K-1927	Connecting Rod Only (includes Cap No. 12)	2.25
6	WOCBX	K-1957	Wrist Pin Screw Locking Plate	.03
7	WOCB2	K-1955	Wrist Pin Lock Screw	.12
8	WOCPI	K-1933	Connecting Rod Bolt	.15
9	WOCFY	K-1930	Connecting Rod Shim	.07
10	WOCDA	K-1928	Connecting Rod, Upper Bearing, Large	.95
11	WOCDI	K-1929	Connecting Rod, Lower Bearing, Small	.95
12	WOCHE		Connecting Rod Bearing Cap (not sold without rod)	
13	WOCHE	K-1934	Connecting Rod Bolt Nut, 5/16x24	.05
14	WOCHE	XK-2607	Cotter Pin	.01
15	WOCIB	K-1305	Crankshaft Gear, Two Keyways, Straight Cut Teeth	.75
	WOCIK	K-1306	Crankshaft Gear, Two Keyways, Spiral Cut Teeth	.75
16	WOCIC	K-1307	Special Offset Key	.07
17	WOCIE	K-1300	Crankshaft	25.00
18	WOCIG	K-1301	Crankshaft Oil Reducing Plug	.05
19	WOCIH	K-1018	Crankshaft Front Bearing, Lower Half	1.00
20	WOCIL	K-1017	Crankshaft Front Bearing, Upper Half	1.00
21	WOCIO	K-1020	Crankshaft Center Bearing, Lower Half	1.35
22	WOCIP	K-1019	Crankshaft Center Bearing, Upper Half	1.35
23	WOCIS	K-1022	Crankshaft Rear Bearing, Lower Half	1.35
24	WOCIV	K-1021	Crankshaft Rear Bearing, Upper Half	1.35
25	WOCKE	K-1023	Clutch Bearing, Upper Half	1.15
26	WOCKO	K-1024	Clutch Bearing, Lower Half	1.15
27	WOCKD	K-1028	Crankshaft Front and Clutch Bearing Shim	.10
28	WOCKL	K-1013	Crank Case Front Bearing Cap for Crank Shaft	.75
29	WOCKY	K-1037	Bearing Cap Plate, Front	.05
30	WOCME	K-1036	Crank Case Main Bearing Stud, 3/4"x2 19/32"	.10
31	WOCMO	304-W	Crank Case Main Bearing Stud, Lockwasher, 3/8"	.01
32	WOCNA	208-N	Crank Case Main Bearing Stud Nut, 3/8"x24	.05
33	WOCNT	K-1029	Crankshaft Center Bearing Shim	.12
34	WOCNY	K-1014	Crank Case Center Bearing Cap for Crank Shaft	.86
35	WOCOB	K-1037	Bearing Cap Plate Center	.05
36	WOCOC	K-1034	Crankshaft Rear Bearing Shim	.10
37	WOCOF	K-1013 1/2	Crank Case Rear Bearing Cap for Crank Shaft	1.00
38	WOCOG	K-1037	Bearing Cap Plate, Rear	.05
39	WOCOL	K-1028	Clutch Bearing Shim	.08
40	WOCOM	K-1016	Crank Case Clutch Bearing Cap	.80
41	WOCOP	K-1038	Bearing Cap Plate, Clutch	.05
42	WOCPE	K-1101	Oil Sump Cover	.40
43	WOCPO	K-1102	Oil Sump Cover Gasket	.20
44	WOCRU	XK-1512	Oil Sump Cover Screw, 10x24x3/8" (16 required)	.02
45	WOCSE	KD-1863	Bolt Holding Crank Case to Frame, Rear Right	.25
46	WOCSS	KD-1864	Bolt Holding Crank Case to Frame, Rear Left	.25
47	WOCSS	KD-1862	Bolt Holding Crank Case to Frame, Front	.25
48	WOCSS	KD-1862	Bolt Holding Crank Case to Frame, Front	.25
49	WODAF	KD-1865	Washer for Bolt, Rear Left	.10
50	WODAG	K-1008	Nut for Motor Bolt	.08
51	WODAL	302-W	Baffle Plate Screw Lock Washer	.01
52	WODAM	KD-1063	Baffle Plate Screw No. 10 24x1 1/2 (Five Used), Short	.05

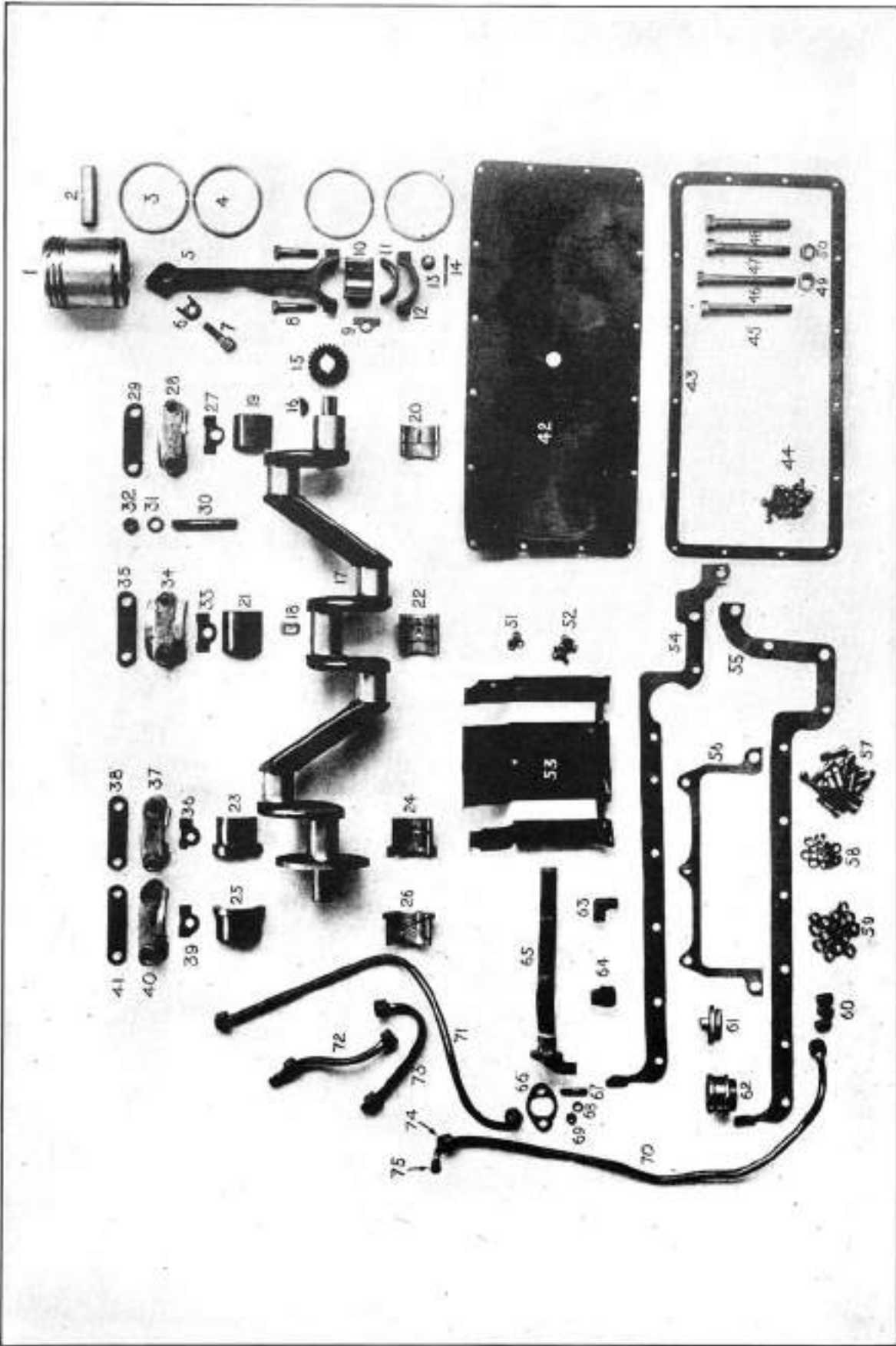

I—MOTOR PARTS

MOTOR PARTS—(Plates I-II)

Photo No.	Code	Parts No.	NAME	Price
53	WODAS	KD-1060	Baffle Plates (Two Used).....	\$.35
54	WODAX	K-1002	Crank Case Gasket, Left Half.....	.05
55	WODAZ	K-1003	Crank Case Gasket, Right Half.....	.05
56	WODBE	K-1003	Crank Case Gasket, Rear.....	.03
57	WODBO	K-1004	Crank Case Flange Bolt, 1/4", 18x1 3/4".....	.05
58	WODAL	302-W	Crank Case Flange Bolt Lockwasher, 1/4".....	.01
59	WODCE	214-N	Crank Case Flange Bolt Nut, 1/4"x28".....	.05
60	WODCO	K-1104	Crank Case Drain Plug, 3/8".....	.05
61	WODCU	K-1118	Oil Filler Cap.....	.75
62	WODDA	K-1116	Oil Filler Extension.....	.15
63	WODEB	K-1090	Oil Pipe Elbow, 90".....	.25
64	WODEH	K-1054	Fly Wheel Inspection Plug, 3/8".....	.05
65	WODEJ	K-111	Oil Outlet Elbow Flange with Screen.....	1.15
66	WODEK	K-1110	Gasket for Oil Outlet Elbow.....	.03
	WODER	K-1129	Oil Strainer Reinforcing Ring.....	.05
67	WODEN	K-1111	Oil Outlet Elbow Seal.....	.03
68	WODAL	302-W	Oil Outlet Elbow Stud Lockwasher.....	.01
69	WODET	214-N	Oil Outlet Elbow Stud Nut.....	.05
70	WODEX	K-153	Oil Suction Pipe, Complete.....	.60
71	WODEF	K-154	Oil Supply Pipe, Complete.....	.50
72	WODEO	K-152	Oil Gauge Pipe, Complete.....	.40
73	WODGO	K-157	Oil By-Pass Pipe, Complete, New Style, Center to Center of Nipples, 4".....	.60
	WODGU	K-155	Oil By-Pass Pipe, Complete, Old Style, Center to Center of Nipples, 4 1/2".....	.60
74	WODHA	K-1563	Oil Pipe Union Nipple.....	.02
75	WODHI	K-1564	Oil Pipe Union Nut.....	.05
76	WODIB	K-1742	Intake Valve.....	1.00
77	WODIC	K-1743	Exhaust Valve, Silchrome.....	1.30
78	WODIF	K-1738	Cylinder Valve Guide.....	.40
79	WODIQ	K-1744	Cylinder Valve Spring, Exhaust and Intake.....	.10
80	WODIL	K-1746	Cylinder Valve Spring Cup.....	.03
81	WODIM	K-1748	Cylinder Valve Spring Retaining Pin.....	.02
82	WODIS	K-169	Cylinder Valve Tappet Assembly, Complete.....	2.00
83	WODIY	B-1591	Cylinder Valve Tappet Adjusting Screw, 1/32"x37".....	.10
84	WODJA	K-1670	Cylinder Valve Tappet Adjusting Screw Nut.....	.05
85	WODJI	K-1628	Cylinder Valve Tappet Guide.....	.90
86	WODKA	K-1627	Cylinder Valve Tappet (Old Style Tappet 1 1/8" Long—New Style 1 3/8" Long)	.75
87	WODKI	K-1636	Cylinder Valve Tappet Guide Gasket.....	.02
88	WODLE	164-S	Cylinder Valve Tappet Guide Clamp Screw, 10x24x3/8".....	.03
	WODLH	K-1636	Cylinder Valve Tappet Guide Clamp Screw, 12x24x3/8".....	.03
89	WODLO	K-1635	Cylinder Valve Tappet Guide Clamp.....	.10
90	WODLI	K-1608	Camshaft, New Style, High Lift.....	10.00
	WODMA	K-1600	Camshaft, Old Style.....	10.00
91	WODMY	K-1620	Camshaft, Rear Bearing.....	1.35
92	WODNO	K-1612	Camshaft, Center Bearing Split.....	1.75
93	WODNU	K-1618	Camshaft, Front Bearing.....	1.50
94	WODOD	408-Key	Camshaft, Key No. 8.....	.02
95	WODOH	K-1606	Camshaft Gear, Straight Cut Teeth.....	1.50
	WODOL	K-1607	Camshaft Gear, Spiral Cut Teeth.....	1.50
96	WODQJ	K-1601	Camshaft Gear Locknut, 1/2"x20".....	.10
97	WODOK	K-1603	Camshaft Cotter Pin, 3/32"x1".....	.01
98	WODON	301-W	Camshaft Bearing Set Screw Washer.....	.01
99	WODOR	K-1613	Camshaft Bearing Set Screw, Front and Rear.....	.05
100	WODOT	K-1613	Camshaft Bearing Set Screw, Center.....	.05
101	WODOZ	K-1201	Gear Case Cover Gasket.....	.07
102	WODAL	302-W	Gear Case Cover Screw Lockwasher.....	.01
103	WODPI	K-1202	Gear Case Cover Screw, Short, 10"x24"x3/4".....	.02
104	WODPY	K-1090	Oil Pipe Elbow.....	.25
105	WODRA	K-1200	Gear Case Cover.....	3.00
106	WODRI	K-1560	Oil Gauge Locknut, 1/2"x24".....	.05
107	WODSA	XK-1262	Oil Gauge felt Washer.....	.05
108	WODSI	K-1558	Oil Gauge (20 Pounds Pressure).....	2.00
	WODSO	K-1558-A	Oil Gauge (50 Pounds Pressure).....	2.00
109	WODSY	K-1203	Gear Case Cover Screw, Long, 10"x24"x1 1/8", for Oil Gauge Strap.....	.03
110	WODTO	302-W	Gear Case Cover, Long Screw Washers for Oil Gauge Strap Screw.....	.01
111	WODUD	XK-3610	Gear Case Cover, Long Screw Nut for Oil Gauge Strap.....	.03
112	WODUJ	K-5098	Oil Gauge Strap.....	.15
113	WODUK	K-1704	Cylinder (Bottom Flange 1/8" Thick).....	11.00
	WODUL	K-1703-A	1/2" Cylinder Shim.....	.30
	WODUM	K-1703-B	1/4" Cylinder Shim.....	.30
	WODUN	K-1704-A	High Compression Cylinder (Bottom Flange 1/16" Thick).....	11.00
114	WODUN	214-N	Exhaust Manifold Stud Nut.....	.05
115	WODAL	302-W	Exhaust Manifold Stud Lockwasher.....	.01
116	WODUT	K-1711	Exhaust Manifold Stud, 1/2"x28".....	.05
117	WODUV	214-N	Inlet Manifold Stud Nut.....	.05
118	WODAL	302-W	Inlet Manifold Stud Lockwasher.....	.01
119	WOEBA	K-1711	Inlet Manifold Stud, 3/4"x28".....	.05

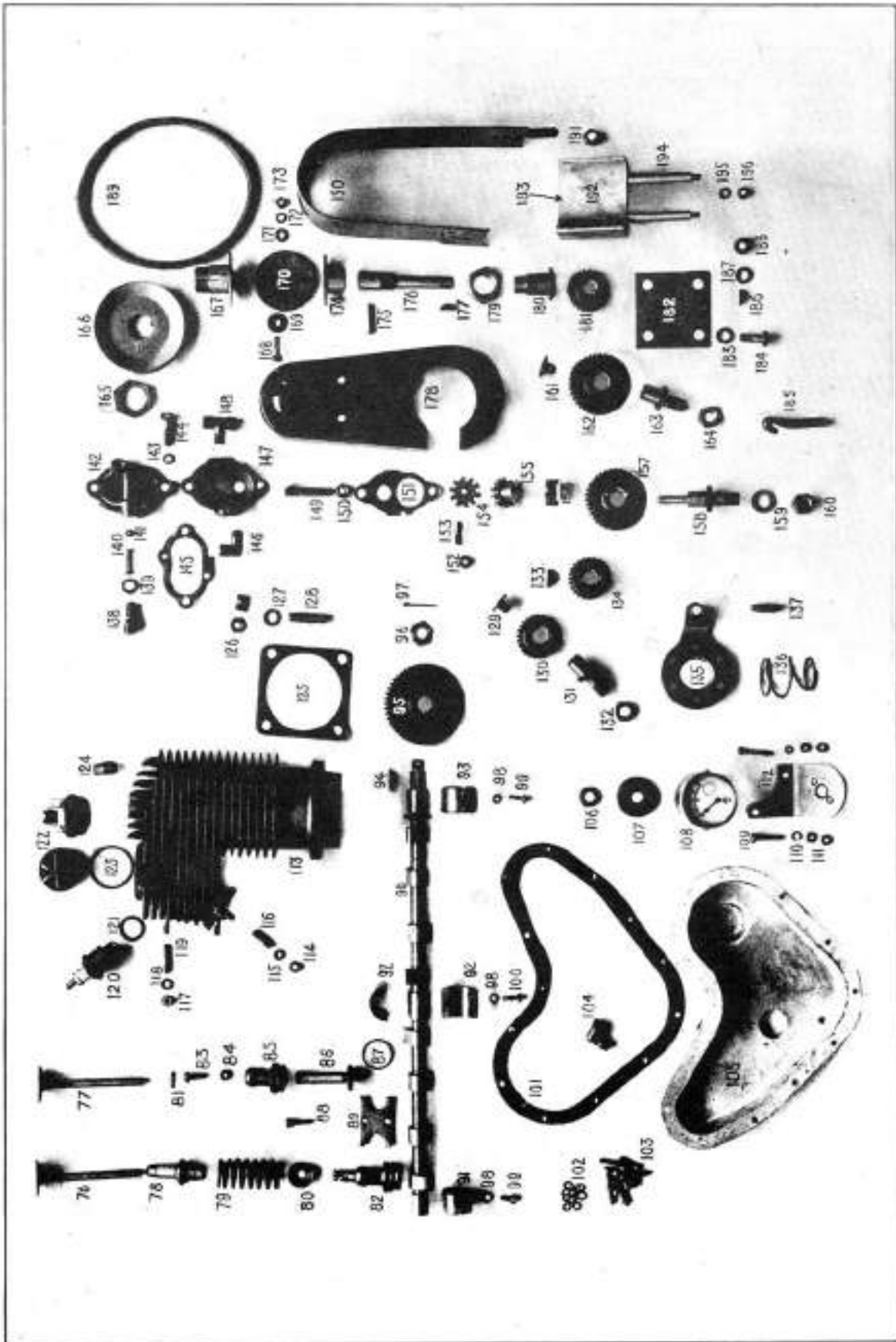

II—MOTOR PARTS

MOTOR PARTS— (Plate II)

Photo No.	Code	Parts No.	NAME	Price
120	WOEBI	K-1100	Spark Plug	\$ 1.00
121	WOEBY	XK-1157	Spark Plug Gasket	.02
122	WOECA	K-1762	Cylinder Valve Plug	.50
123	WOECI	K-1761	Cylinder Valve Plug Gasket	.05
124	WOECS	H-2484	Cylinder Plug	.05
125	WOECY	K-1761	Cylinder Flange Gasket	.02
126	WOEDE	K-1008	Cylinder Stud Nut, 3/8"x24	.08
127	WOEMO	304-W	Cylinder Stud Lockwasher	.01
128	WOEDU	K-1007	Cylinder Stud	.05
129	WOEFA	K-1049	Screw for Cam Idler Gear	.10
130	WOEPI	K-106	Cam Idler Gear, Complete with Bushing, Straight Cut Teeth	1.50
	WOEDO	K-1012	Cam Idler Gear, Oil Pump and Magneto Idler Gear Bushing	.30
	WOEDR	K-116	Cam Idler Gear, with Bushing, Spiral Cut Teeth	1.50
	WOEDO	K-1012	Cam Idler Gear Bushing	.30
	WOEJU	K-1055	Cam Idler Gear Only	1.00
131	WOEPI	K-1056	Cam Gear Idler Stud	.50
132	WOEGA	224-N	Nut for Cam Gear Idler Stud	.10
133	WOEGH	K-1307	Special Offset Key for Crankshaft Gear	.01
134	WOEGI	K-1305	Crank Shaft Gear, Two Keyways, Straight Cut Teeth	.75
	WOEGL	K-1306	Crank Shaft Gear, Two Keyways, Spiral Cut Teeth	.75
135	WOEGN	K-162	Cam Brake Plate Assembly, Old Style (as illustrated)	1.50
	WOEGO	K-161	Cam Brake Plate Assembly, New Style	1.50
136	WOEHL	K-1617	Cam Brake Plate Spring	.10
137	WOEHL	K-1618	Cam Brake Plate Anchor Stud	.15
138	WOEHM	K-1573	Oil Pipe Straight Connection, Used with 20 Pound Gauge	.08
	WOEHP	K-1573	New Tyar High Pressure Oil Pipe, Straight Connection, Used with 50 Pound Gauge	.20
139	WOEHO	K-1569	Oil Pipe Straight Connection Locknut	.05
140	WOEHS	K-1557	Oil Pump Spacing, for 20 Pound Pressure, not Used with 50 Pound Gauge	.01
141	WOEJE	XK-1718	Oil Pump Check Ball, 5/16"	.01
142	WOEJO	K-1550	Oil Pump Cover	.75
143	WOEJL	302-W	Oil Pump Cover Stud Lockwasher	.01
144	WOEKA	K-1568	Oil Pump Cover Cap Bolt, 1/4"x18	.08
145	WOEKI	K-1555	Oil Pump Cover Gasket	.02
146	WOEKS	XK-109	Oil Pipe Elbow	.25
	WOEJQ	K-150	Oil Pump Complete, less Connections	7.35
147	WOEKY	K-1500	Oil Pump Body	1.75
148	WOELA	K-1571	Oil Pipe Tee Connection	.30
149	WOELB	K-1206	Oil Pump Stud, 5/16"x 18	.05
150	WOELY	K-204	Oil Pump Stud Nut	.04
151	WOELP	K-1505	Oil Pump Body Gasket	.02
152	WOELS	214-N	Oil Pump Lower Gear Stud Nut, 1/4"x 28	.05
	WOELAL	302-W	Oil Pump Lower Gear Stud Lockwasher	.01
153	WOEFAZ	K-1515	Oil Pump Lower Gear Stud	.05
154	WOEMB	K-1533	Oil Pump, Lower Gear	.70
155	WOEMH	K-1532	Oil Pump, Upper Gear	.75
156	WOEMS	K-1534	Oil Pump Coupling	.30
157	WOEMY	K-102	Oil Pump Driving Gear, with Bushing, Straight Teeth	1.15
	WOEDO	K-1012	Oil Pump Driving Gear Bushing	.30
	WOENA	K-105	Oil Pump Driving Gear, with Spiral Cut Teeth with Bushing	1.15
158	WOENE	K-1009	Oil Pump Driving Gear Stud, New Style, Supersedes the One Shown	.40
159	WOENG	306-W	Oil Pump Driving Gear Shaft Lockwasher	.03
160	WOENO	K-1010	Oil Pump Driving Gear Shaft Nut, 1/2"x 20	.10
161	WOEPA	K-1049	Screw for Magneto Idler Gear, 3/4"x 24	.10
162	WOEPI	K-104	Magneto Idler Gear with Bushing, Straight Cut Teeth	1.00
	WOEPIK	K-103	Magneto Idler Gear with Bushing, Spiral Cut Teeth	1.00
	WOEDO	K-1012	Magneto Idler Gear Bushing	.30
163	WOEPIJ	K-1056	Magneto Idler Gear Stud	.50
	WOELY	K-1048	Gasket for Magneto Idler Gear Stud	.05
164	WOEPIK	K-1010	Nut for Idler Gear Stud	.10
165	WOEPIU	K-4035	Magneto Pulley Nut, 1"x 20	.20
166	WOEHS	K-4036	Magneto Pulley	2.00
	WUJON	K-149	Magneto Coupling Complete	3.25
167	WOENE	KD-146	Magneto Coupling Pulley Side, Assembled	1.25
168	WOENK	KD-1407	Magneto Coupling Bolt (Four Used)	.20
169	WOERL	GK-6149	Magneto Coupling Plain Washer, Large	.05
170	WOERO	KD-1406	Magneto Coupling Disc	.25
171	WOERY	BD-4398	Magneto Coupling Bolt Plain Washer, Small	.03
172	WOEDAL	302-W	Magneto Coupling Bolt Lockwasher	.01
173	WOESP	214-N	Magneto Coupling Bolt Nut	.05
174	WOEST	KD-147	Magneto Coupling, Magneto Side, Assembled	.40
175	WOESY	K-1482	Magneto Shaft Coupling Taper Pin	.04
176	WOETE	K-4005	Magneto Shaft	.75
177	WRAOC	XK-2373	Magneto Shaft Coupling Key, No. 3	.02
178	WORTU	KD-4021	Generator Belt Case	.75
179	WOEVI	K-1402	Magneto Shaft Bearing Nut, 7/4"x 14"	.15

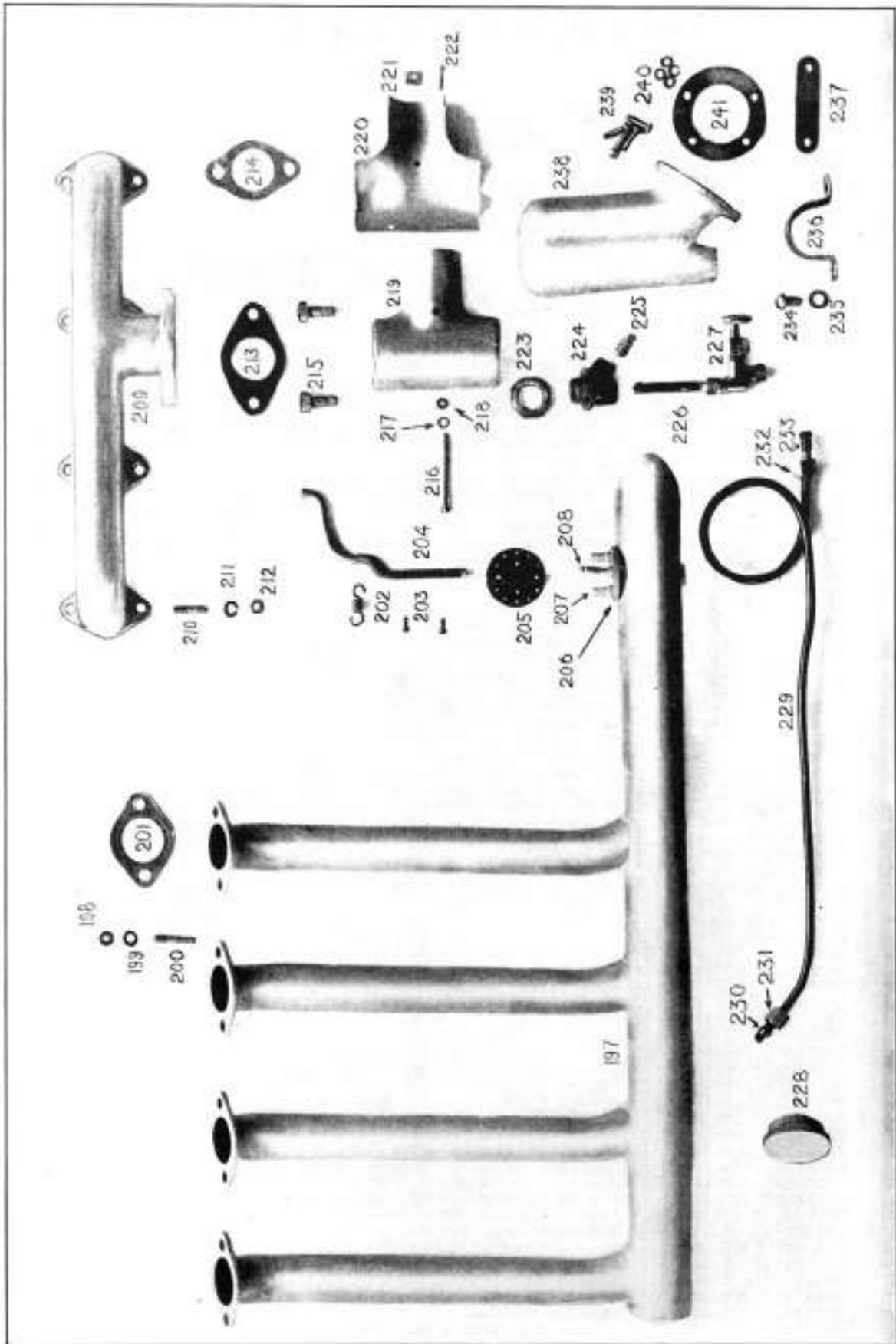

III—MANIFOLDS, BREATHER, TANK FITTINGS, ETC.

MOTOR PARTS—(Plate II)

Photo No.	Code	Part No.	NAME	Price
180	WOEVS	K-1401	Magneto Shaft Bearing	\$ 1.40
181	WORWE	K-1404	Magneto Gear, Straight Cut Teeth	1.00
	WORWX	K-1406	Magneto Gear, Spiral Cut Teeth	1.00
	WOELY	K-1048	Magneto Gear Gasket	.05
182	WORWO	K-4080	Magneto Base Shim	.05
183	WOCMO	304-W	Magneto Base Bolt Washer	.01
184	WOEXA	K-4092	Magneto Base Bolt	.25
185	WOEXI	K-4071	Magneto Scrap Hook	.28
186	WRAOC	XK-2373	Magneto Shaft Key, No. 1	.02
187	WOCMO	304-W	Magneto Shaft Washer	.01
188	WOEYO	70-N	Magneto Shaft Nut, Special	.15
189	WOEZA	K-406	Generator Pulley Belt, Complete	.50
190	WOEZI	K-407	Generator Saddle Strap, Complete	.72
191	WOFAK	207-N	Magneto Scrap Bolt Nut	.05
192	WOFAN	K-4050	Generator Saddle, Only	1.00

MANIFOLDS, BREATHER, TANK FITTINGS, ETC. (Plate III)

193	WOFAR	K-405	Generator Saddle, Complete with Stud	1.70
194	WOPAT	K-4055	Generator Saddle Stud	.35
195	WODAL	302-W	Generator Saddle Stud Lockwasher	.01
196	WOPAX	220-N	Generator Saddle Stud Nut	.03
197	WOEBA	KD-182	Exhaust Pipe Assembly, Complete	12.25
198	WOLUN	214-N	Exhaust Manifold Stud Nut	.05
199	WODAL	302-W	Exhaust Manifold Stud Lockwasher	.01
200	WOLUT	K-1711	Exhaust Manifold Stud, 1/2" x 28"	.05
201	WOOCI	KD-1816	Exhaust Pipe Flange Gasket (Four Used)	.05
202	WOOCB	KD-1825	Exhaust Cutout Spring	.10
203	WOOCY	KD-1829	Exhaust Cutout Disc Screw, 5/32" x 5.16" (Two Used)	.03
204	WOODE	KD-1830	Exhaust Cutout Lever	.25
205	WOODO	KD-1831	Exhaust Cutout Disc	.05
206	WOODU	KD-1832	Exhaust Cutout Plate	.10
207	WOOFA	KD-1833	Exhaust Cutout Lever Stop (Two Used)	.06
208	WOOFB	KD-1834	Exhaust Cutout Spring Post	.06
209	WOOFY	KD-1721	Inlet Manifold	6.50
210	WOEBA	K-1711	Intake Manifold Stud	.05
211	WODAL	302-W	Intake Manifold Stud Lockwasher	.01
212	WODUV	214-N	Intake Manifold Stud Nut	.05
213	WOOGN	KD-1776	Carburetor Gasket	.03
214	WOOHE	KD-1725	Inlet Manifold Gasket (Four Used)	.03
215	WOOHL	K-1780	Carburetor Flange Bolt	.10
	WOOGH	K-1775	Zenith Carburetor T-4, Complete	20.00
	WOONO	K-1872	Carburetor Wind Shield for Winter Riding	1.00
	WOOFU	K-186	Carburetor Stove, Complete	1.15
216	WOOHM	KD-1811	Carburetor Stove Screw 5/32", Flat Head	.06
217	WOOHU	300-W	Carburetor Stove Screw Lockwasher, 5/32"	.01
218	WOOHU	HD-7112	Carburetor Stove Screw Nut, 5/32", Small Hex	.03
219	WOOJE	KD-1810	Carburetor Stove, Two Halves, Each	.45
220	WOOJO	KD-1810	Carburetor Stove, Two Halves, Each	.45
221	WOOUU	KD-1813	Carburetor Stove Screw Spacers	.04
222	WOOKA	175-S	Carburetor Stove Clamp Screw, 8/32" (Two Used)	.02
223	WOOKI	XK-2933	Gasoline Outlet Socket Nut, Inside Tank	.20
224	WOOKS	H-6463	Gasoline Outlet Socket	.35
	WUGUG	K-5217	Gasoline Outlet Socket Extension Nipple	.10
225	WOOKY	K-4104	Gasoline Outlet Drain Plug	.05
226	WOOLA	K-613	Gasoline Valve Cock	1.00
227	WOOLB	K-6112	Gasoline Valve Strainer	.15
228	WOOLS	XKD-2958	Filler Cap	.75
	WOOLY	XKD-2957	Filler Cap Gasket	.05
229	WOOMA	K-529	Gasoline Pipe to Carburetor, Complete with Unions	.45
	WOOME	K-5292	Gasoline Pipe Only	.25
230	WOOMI	C-1638	Gasoline Pipe Compression Cone	.02
231	WOOMS	B-1643	Gasoline Pipe Compression Cone Nut	.05
232	WOOMY	H-6461	Gasoline Pipe Union Nut, Tank End	.05
233	WOONE	XK-2813	Gasoline Pipe Union Nipple Tank End	.05
234	WOONG	XK-4734	Gasoline Tank Clip Screw	.05
235	WODAL	302-W	Gasoline Tank Clip Screw Lockwasher	.01
236	WOONT	B-2033	Gasoline Tank Clip	.10
237	WOOPT	B-1634	Gasoline Tank Clip Fiber Washer	.02
238	WOOPB	K-1067	Crankcase Breather	1.00
239	WOOPT	103-S	Crankcase Breather Screws, 10" x 24" x 5/16"	.02
240	WODON	301-W	Crankcase Breather Screw Lockwasher	.01
241	WOORB	K-1069	Crankcase Breather Gasket	.05

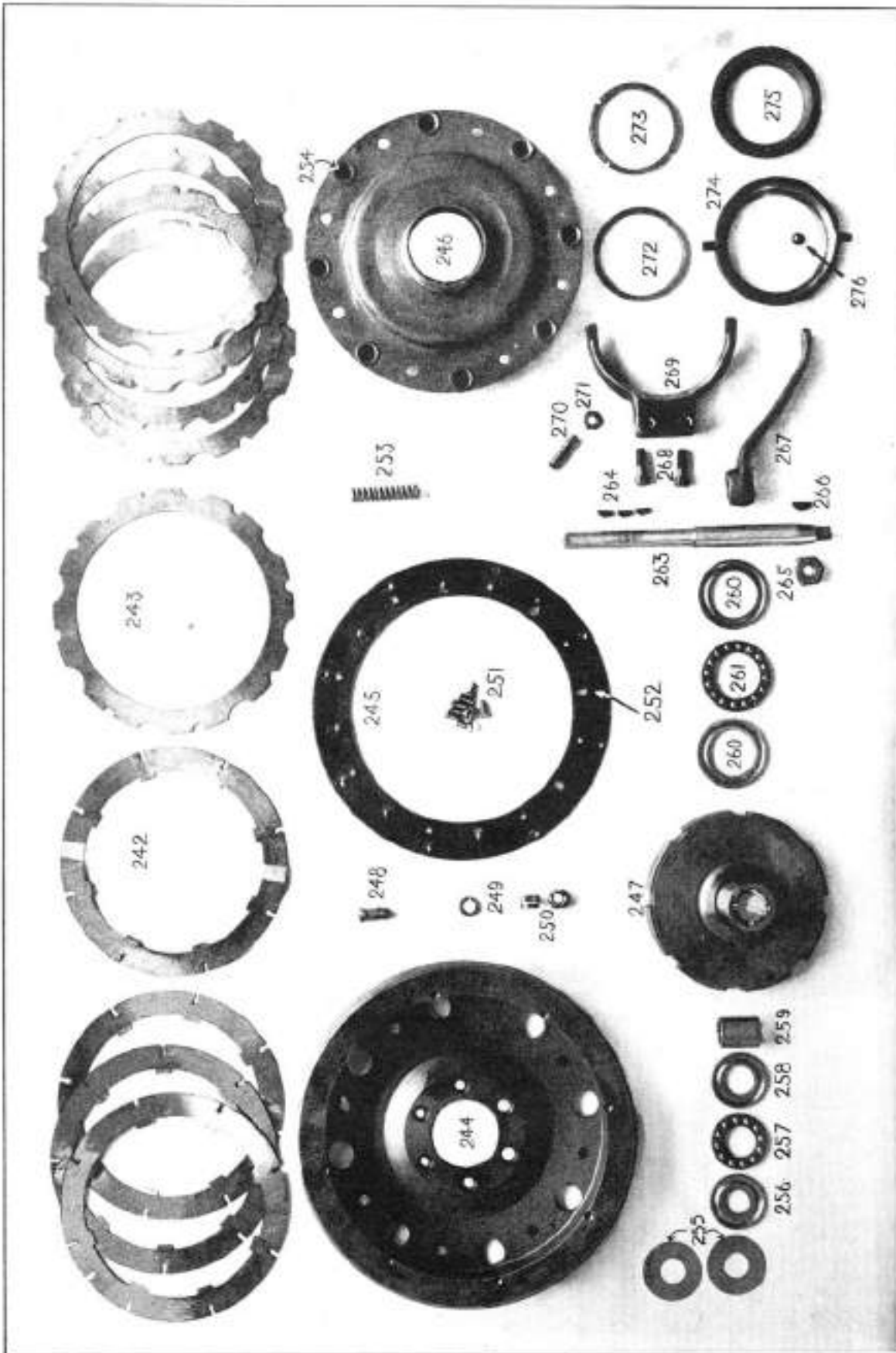

IV—CLUTCH PARTS

CLUTCH PARTS--(Plate IV)

Photo No	Code	Parts No.	NAME	Price
242	WRAAH	K-2638	Clutch Inner Disc, Four	.95
243	WRAAJ	K-2637	Clutch Outer Disc, Five	.95
244	WRAAK	K-2601	Flywheel	7.00
245	WRAAN	K- 201	Clutch Flywheel Plate, Complete	2.10
	WRAAR	G-6303	Clutch Flywheel Plate, Only	.75
246	WRAAT	K- 292	Pressure Plate, Complete with Spring Caps	3.70
	WROIM	K- 291	Pressure Plate Assembly, Complete with Release Collar	8.55
	WROIG	K-2635	Pressure Plate Only, Without Spring Caps	2.50
247	WRAAV	K- 260	Clutch Driving Member, Complete with Bushing	6.95
	WROIM	K-2601	Clutch Driving Member, Only..	6.25
248	WRAAZ	K-2064	Bolt for Flywheel	.10
249	WOCMO	304-W	Lock Washer for Flywheel Bolt	.01
250	WRAEF	208-N	Nut for Flywheel Bolt	.05
	WRAEG	603-C	Cotter Pin for Flywheel Bolt	.01
251	WRAEL	142-S	Screw for Flywheel Plate	.02
252	WRAEM	G-6300	Clutch Flywheel Plate Pin	.06
253	WRARP	K-6309	Clutch Pressure Spring	.10
254	WRARS	XK-2645	Pressure Plate Spring Cup	.15
255	WRARW	K-1310	Crankshaft Thrust Bearing Shim	.05
256	WRAJD	K-2369	Crankshaft End Thrust Ball Race, Front	1.00
257	WRAJF	K- 236	Crankshaft End Thrust Ball Retainer, Complete with Balls	.55
	WRAJK	K-2370	Crankshaft End Thrust Ball Retainer, Only	.40
258	WRAJR	K-2368	Crankshaft End Thrust Ball Race, Rear	1.00
259	WRAIT	K-2611	Clutch Driving Member Bushing	.70
260	WRAIV	K-2765	Clutch Thrust-Bearing Race	1.15
261	WRAIX	K- 276	Clutch Thrust-Bearing Retainer, Complete with Balls	.65
	WRAIZ	K-2764	Clutch Thrust-Bearing Retainer, Only	.45
263	WRAOB	K-2931	Clutch Release Shaft	1.35
	WRAOD	K-2935	Clutch Release Shaft, New Style	1.35
264	WRAOC	XK-2373	Clutch Release Fork Key No. 3	.02
265	WRAOF	225-N	Clutch Release Shaft Nut, 7/16"x 20	.05
266	WRAOG	XK-2347	Clutch Release Lever Key No. 6	.02
267	WRAOL	K-2522	Clutch Release Lever	.75
268	WRAOP	K-2516	Clutch Release Fork Clamp Screw	.10
269	WRAOS	K-2512	Clutch Release Fork	1.25
	WRAOT	K-2515	Clutch Release Fork, New Style	1.25
270	WRAOY	K-1026	Clutch Release Fork Stop Screw	.10
271	WRAUC	K-2611	Clutch Release Fork Stop Screw Locknut	.03
272	WRAUF	K-2649	Clutch Cone Spring Lockwasher	.01
273	WRAUG	K-2920	Clutch Release Cone Locknut	1.00
274	WRAUL	K-2900	Clutch Release Collar	2.20
275	WRAUM	K-2910	Clutch Release Cone	1.50
276	WRAUP	XK-1718	Clutch Release Steel Ball, (28 used)	.01

TRANSMISSION PARTS--(Plate V)

277	WRAUS	K-3068	Engine Sprocket, 17 Tooth, One Keyway	1.65
278	WRAYK	K-3067	Engine Sprocket, 18 Tooth, One Keyway	1.65
279	WRAYO	K-3066	Engine Sprocket, 15 Tooth, One Keyway	1.65
280	WRAYT	K-3065	Engine Sprocket, 14 Tooth, One Keyway	1.65
281	WRAYU	K-3069	Engine Sprocket Key for One Keyway	.92
	WRFAE	K-3063	Engine Sprocket, 17 Tooth, Four Keyways	1.65
	WRFAF	K-3062	Engine Sprocket, 16 Tooth, Four Keyways	1.65
	WRFAG	K-3064	Engine Sprocket, 15 Tooth, Four Keyways	1.65
	WRFAH	K-3061	Engine Sprocket, 14 Tooth, Four Keyways	1.65
	WROAG	XK-2347	Engine Sprocket Key for Four Keyways	.92
282	WRBAS	K-3051	Engine Sprocket Locknut	.10
283	WRBAW	K-3504	Small Bevel Gear Shim	.92
284	WODOD	40H-Key	Small Bevel Gear Key	.92
285	WRFEH	K-3400	Small Bevel Gear, Spiral Cut	6.75
	WRFEJ	K-3500-A	Small Bevel Gear, Straight Cut	6.75
286	WREEK	K- 333	Large Bevel Gear, Spiral Cut and Driving Gear Assembly	11.00
	WREEN	K- 333-A	Large Bevel Gear, Straight Cut and Driving Gear Assembly	11.00
287	WREER	K-3353	Large Bevel Gear, Only, Spiral Cut	7.50
	WREET	K-3353-A	Large Bevel Gear, Only, Straight Cut	7.50
288	WREEV	K-3334	Main Driving Large Bevel Gear Bushing	.65
289	WREIF	K-3333	Main Driving Gear, Only	3.50
290	WREIG	K-3001	Spline Shaft Collar	.10
291	WREIL	K-3405	Countershaft Gear Unit, Only (16 Tooth Low Gear, Supersedes K-3400 with 18 Teeth)	14.00
	WRDIM	K-3400	Countershaft Gear Unit, Only, Old Style	14.00
292	WREIP	208-N	Countershaft Gear Bearing Stud Nut	.05
293	WOCMO	304-W	Countershaft Gear Bearing Stud Lockwasher	.01
294	WREIV	K-1435	Countershaft Gear Bearing Stud	.10

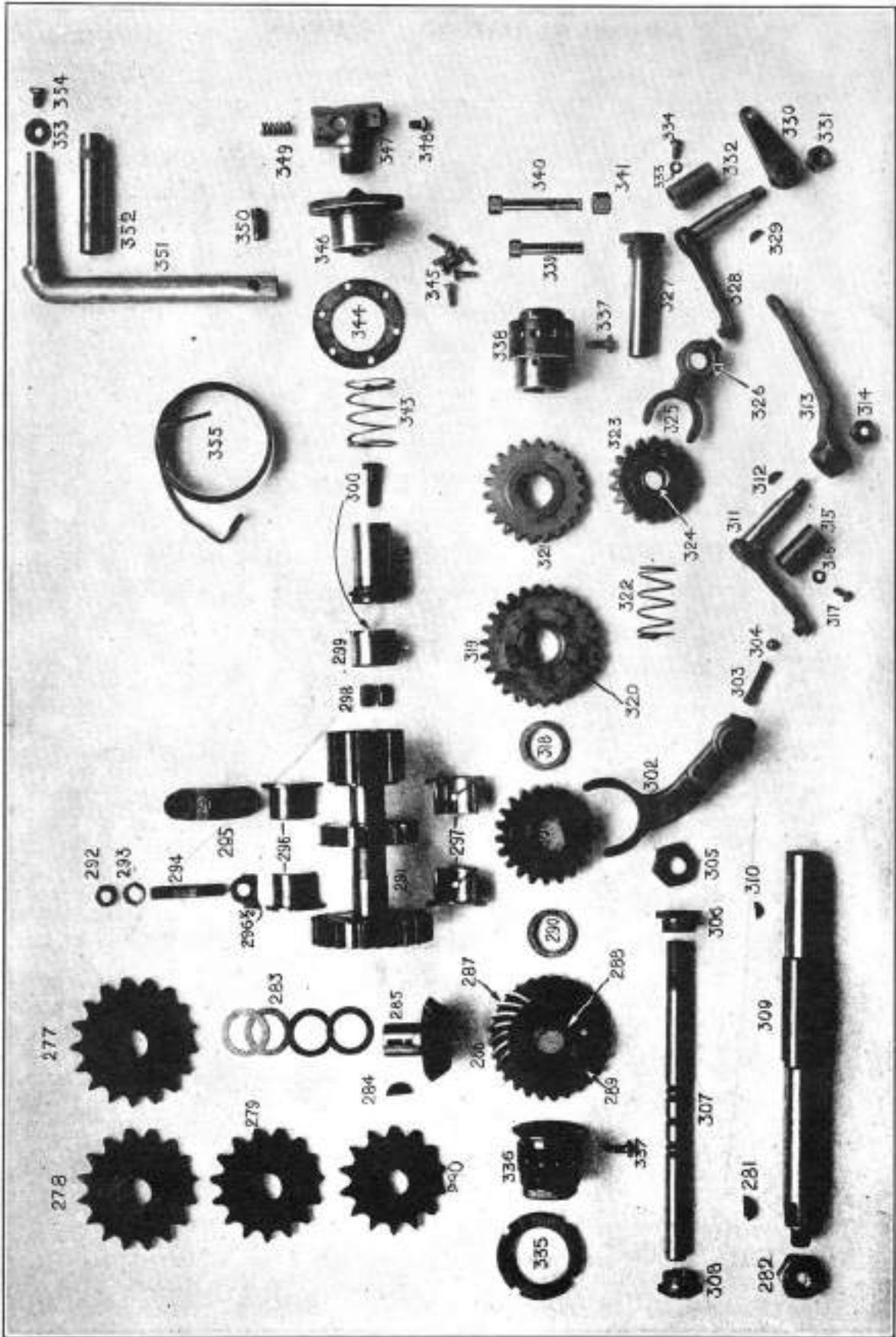

V-TRANSMISSION PARTS

TRANSMISSION PARTS—(Plate V)

Photo No.	Code	Parts No.	NAME	Price
295	WRBOD	K-1842	Countershaft Gear Bearing Cap60
296	WRBOP	G-6341	Countershaft Bearing, Lower80
296 1/2	WRBQH	K-1843	Countershaft Bearing Shim08
297	WRBQM	G-6340	Countershaft Bearing, Upper80
298	WRBQR	K-3401	Foot Starter Jaw Dowel Pin02
299	WRBOT	K-3411	Foot Starter Jaw, New Style95
	WRBOX	K-3414	Foot Starter Jaw, Old Style95
300	WRBOZ	K-3415	Foot Starter Jaw, Screw 5/16"x 24"10
301	WRBUD	K-3315	Shifter Gear	4.25
301	WRBUK	K-3605	Gear Shifter Fork, New Style, Supersedes K-3507	2.50
	WRBUN	K-3607	Gear Shifter Fork, Old Style	1.35
303	WRBUR	K-3612	Gear Shifter Fork Locking Spring10
304	WRBUT	XK-1718	Gear Shifter Fork Locking Spring Ball01
305	WRBUX	K-3603	Gear Shifter Shaft Locknut15
306	WRBUZ	K-3604	Gear Shifter Shaft Adapter35
307	WRBYA	K-3601	Gear Shifter Shaft	1.14
308	WRBYB	K-3602	Gear Shifter Shaft Cap Nut25
	WRBEB	K-3609	Gear Shifter Shaft, Old Style75
	WRBED	G-6352	Gear Shifter Cap Nut, Old Style30
	WRBIK	K-3608	Gear Shifter Fork Brew, 1/2 x 24, Old Style08
	WRBIV	K-3648	Gear Shifter Shaft Screw, Old Style60
	WRBAP	G-6359	Gear Shifter Stop Pin, Old Style05
	WRBAO	G-6340	Gear Shifter Stop Pin Bushing, Old Style25
	WRBAI	G-6343	Gear Shifter Stop Pin Adjusting Brew, Old Style05
	WRBAS	G-6359	Gear Shifter Stop Pin Spring, Old Style05
	WRBAW	204-N	Gear Shifter Stop Pin Locknut, Old Style04
	WRBED	G-6347	Gear Shifter Shaft Bushing, Large, Old Style35
309	WRBYC	K-3005	Spline Shaft, with One Keyway	2.50
	WRBYF	K-3000	Spline Shaft, Old Style with Four Keyways	2.50
310	WRBOC	XK-2373	Reverse Driving Gear Key02
311	WRBYI	K-3100	Gear Shifter Finger	1.00
312	WRBOE	XK-2373	Gear Shifter Finger Key02
313	WRBYM	K-3106	Gear Shifter Finger Lever75
314	WRBIAH	K-3109	Gear Shifter Finger Nut05
315	WRBIAJ	K-3107	Gear Shifter Finger Bushing35
316	WODON	301-W	Gear Shifter Finger Bushing Lockwasher01
317	WRBIAK	XK-1512	Gear Shifter Finger Bushing Screw, 10x2402
318	WRBIAI	K-3001	Spline Shaft Collar10
319	WRBIAF	K- 337	Low Speed Gear, Complete, 26 Teeth, Supersedes K-336	3.75
	WRBIAV	K- 336	Low Speed Gear, Complete, Old Style, 24 Teeth	3.75
	WRBIAZ	K-3337	Low Speed Gear Bushing, Only50
320	WRBIAZ	K-3949	Reverse Driving Gear, 22 Teeth, Supersedes, K-3941	2.25
321	WRBIB	K-3941	Reverse Driving Gear, 19 Teeth, Old Style	2.25
322	WRBIF	K-3948	Reverse Gear Retaining Spring07
323	WRBIG	K-3942	Reverse Shifter Gear	2.75
324	WRBIEI	K-3943	Reverse Shifter Gear Bushing30
325	WRBIEM	K-3946	Reverse Gear Shifter Fork, Complete80
	WRBIEP	K-3940	Reverse Gear Shifter Fork, Old Style80
326	WRBIEB	K-3947	Reverse Gear Shifter Fork Bushing50
327	WRBIEW	K-3944	Reverse Gear Shifter Fork Shaft65
328	WRBIIJ	K-3100	Reverse Gear Shifter Finger	1.00
329	WRBOC	XK-2373	Reverse Gear Shifter Finger Key02
330	WRBIIK	K-3935	Reverse Gear Shifter Finger Lever, New Style35
331	WRBIIH	K-3109	Reverse Gear Shifter Finger Nut05
332	WRBIIJ	K-3107	Reverse Gear Shifter Finger Bushing35
333	WODON	301-W	Reverse Gear Shifter Finger Bushing Lockwasher01
334	WRBIIK	XK-1512	Reverse Gear Shifter Finger Lock Screw02
	WRBOEH	K-3998	Reverse Gear Shifter Shaft Plug10
335	WRBIIZ	K-3330	Spline Shaft Bearing Locknut55
336	WRBIOB	K-3331	Spline Shaft Bearing, Right	3.50
337	WRBIOC	K-1030	Spline Shaft Bearing Set Screw, Right or Left Side02
	WRBIOF	K-3329	Spline Shaft Bearing, Right, Felt Washer03
338	WRBIOG	K-3332	Spline Shaft Bearing, Left	3.50
339	WRBIOC	K-1033	Spline Shaft Bearing Bolt, Short, 3/4"x 1615
340	WRBIOF	K-1032	Spline Shaft Bearing Bolt, Long, 3/4"x 2415
341	WRBIOB	207-N	Spline Shaft Bearing Bolt Nut05
	WRDRK	K- 381	Foot Starter Assembly, Complete	8.65
342	WRBIOY	K-3802	Foot Starter Shaft, New Style	1.25
	WRBIUC	K-3800	Foot Starter Shaft, Old Style	1.25
343	WRBIUF	K-3801	Foot Starter Shaft Spring20
344	WRBIUG	K-3805	Foot Starter Housing Gasket03
345	WRBIUJ	K-3807	Foot Starter Housing Screws02
346	WRBIUM	K-3803	Foot Starter Shaft Housing	2.20
347	WRBIUP	K-3843	Foot Starter Crank Socket	1.75
348	WRBIUS	G-6150	Foot Starter Return Spring Set Screw15
349	WRBIYE	G-6153	Foot Starter Socket Snap Spring05

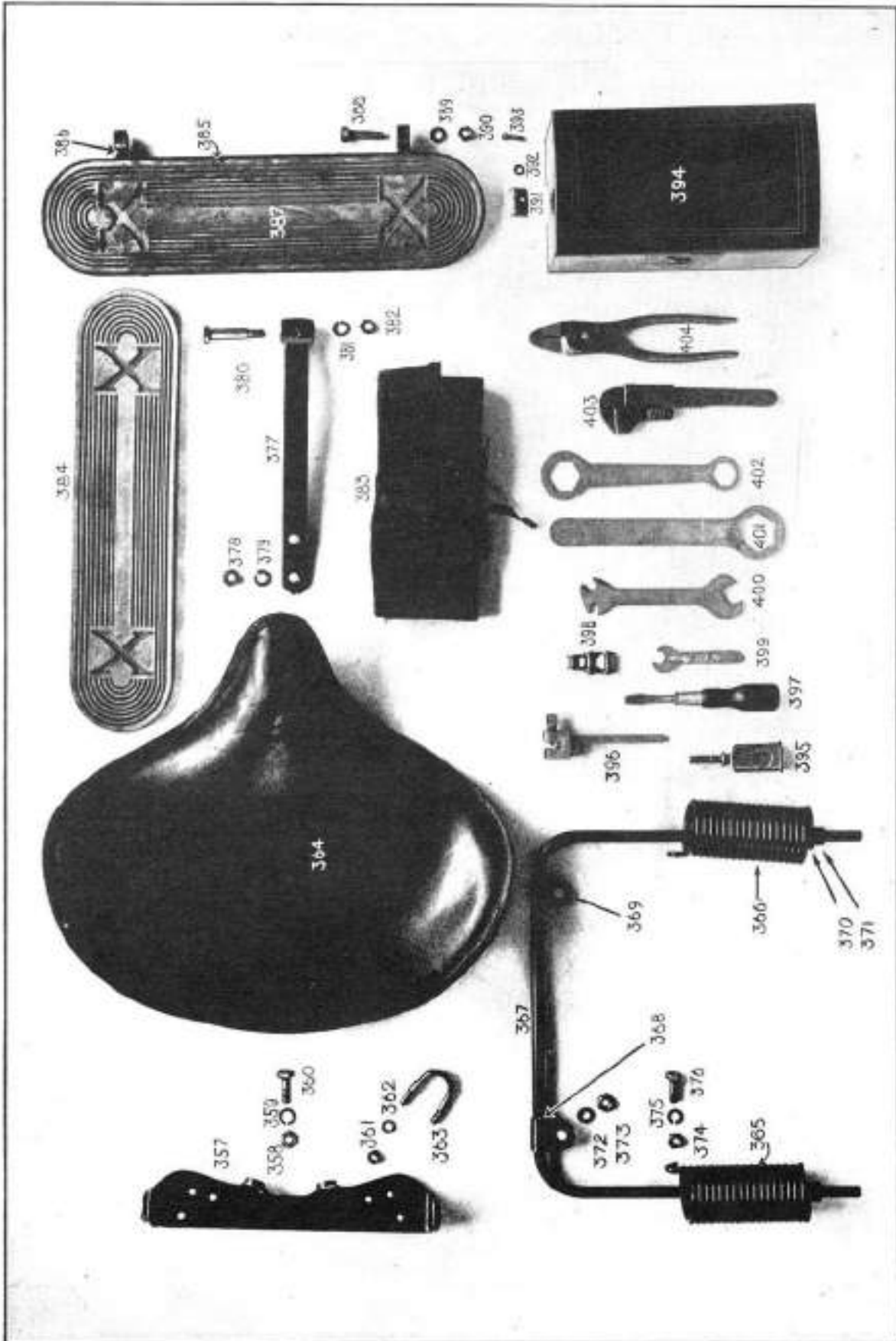

VI—SADDLE, TOOL KIT AND FOOT BOARDS

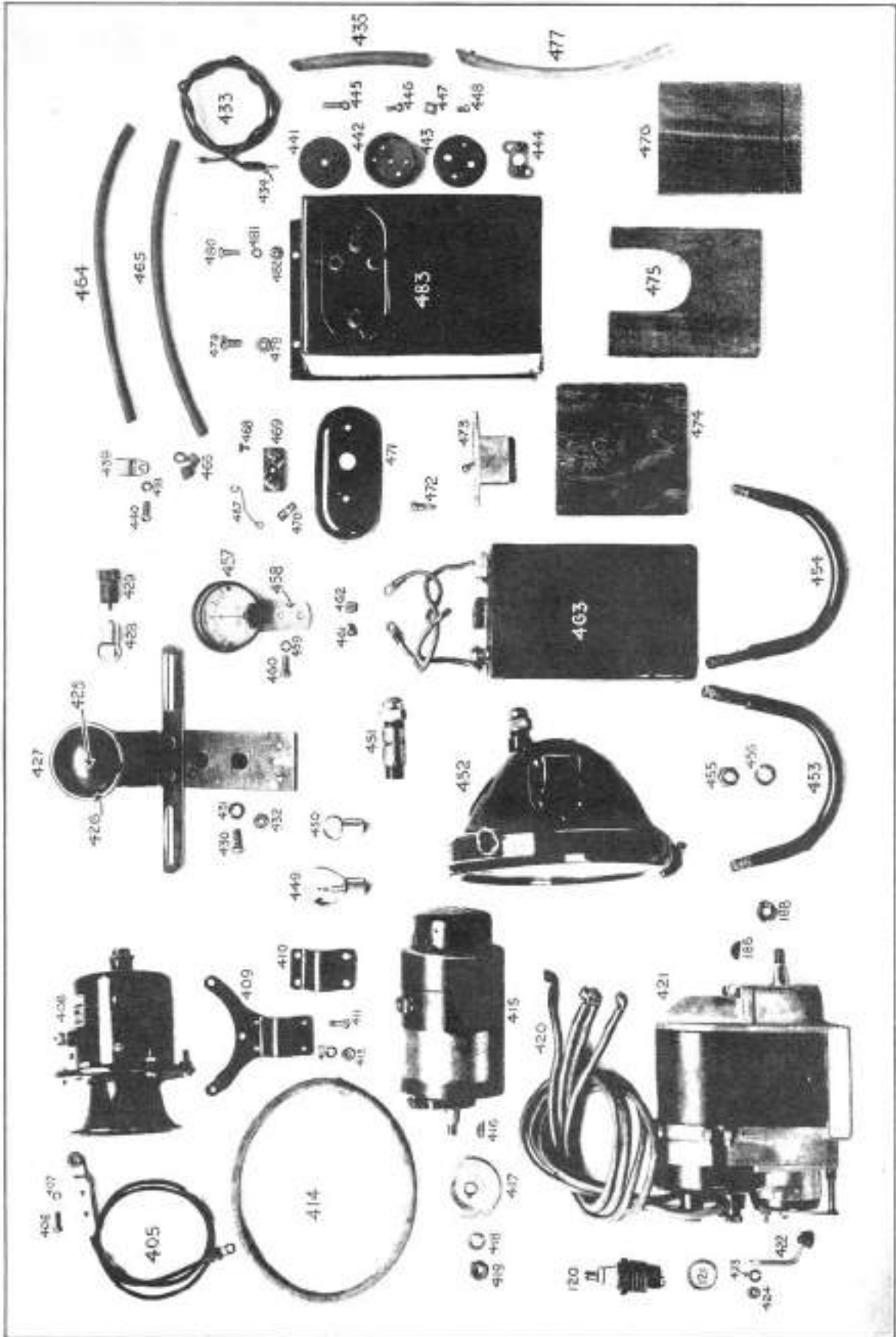

VII—ELECTRICAL EQUIPMENT

TRANSMISSION PARTS—(Plate V)

Item No.	Code	Part No.	NAME	Price
350	WRIYK	K-3844	Foot Starter Socket Stop Pin	.10
351	WRIYO	K-3842	Foot Starter Crank	2.25
352	WRIYR	G-6148	Foot Starter Crank Sleeve	.75
353	WRIYT	G-6149	Foot Starter Sleeve Washer	.05
354	WRIYU	G-6150	Foot Starter Sleeve Screw	.15
355	WROAC	K-3835	Foot Starter Return Spring	.30

SADDLE, TOOL KIT AND FOOTBOARDS—(Plate VI)

357	WUABE	K-5812	Saddle Spring Support	1.50
358	WUABO	304-N	Saddle Spring Support Bolt Nut	.04
359	WUABU	303-W	Saddle Spring Support Bolt Washer	.01
360	WUACE	H-6484	Saddle Spring Support Bolt to Mudguard	.10
361	WUACH	320-N	"U" Bolt Nut	.03
362	WODAL	302-W	"U" Bolt Nut Washer	.01
363	WUACT	K-5816	"U" Bolt Clamp	.30
364	WUACU	KD-4072	Bucket Seat Saddle, Top Only	5.50
	WUADA	K-579	Bucket Saddle, Complete	12.00
365	WUADI	K-5813	Saddle Spring, Right Side	.60
366	WUADY	K-5814	Saddle Spring, Left Side	.60
367	WUAPE	K-5806	Saddle Spring, Bridge	.75
368	WUAFQ	XK-4325	Saddle Spring, Bridge Cotter Pin	.01
369	WUAFI	K-5809	Saddle Spring, Bridge Anchor Clip	.11
370	WUAFU	XK-1830	Saddle Spring, Bridge Lockwasher	.01
371	WUAOE	XK-2492	Saddle Spring, Bridge Nut	.08
372	WUABU	303-W	Saddle Bridge Anchor Clip Lockwasher	.01
373	WUAGS	230-N	Saddle Bridge Anchor Clip Nut	.04
374	WUAGU	204-N	Saddle Spring Bolt Nut	.04
375	WUAGA	303-W	Saddle Spring Bolt Lockwasher	.01
376	WUAGT	K-5260	Saddle Spring Bolt, 5/16" x 24	.08
377	WUAGY	K-5883	Saddle Forward Extension	.65
378	WUAGA	230-N	Saddle Forward Extension Nut	.04
379	WUABU	303-W	Saddle Forward Extension Lockwasher	.01
380	WUAGY	K-5805	Saddle Forward Extension Bolt	.30
381	WUABU	303-W	Saddle Forward Extension Bolt Lockwasher	.01
382	WUAKO	204-N	Saddle Forward Extension Bolt Nut	.04
383	WUARF	K-2462	Tool Kit Complete with Tools	6.38
	WUART	B-2475	Tool Kit Cover, Only	.60
384	WUAKU	XK-2223	Footboard Rubber Mat, Only	.45
385	WUALB	XK-2214	Footboard Plate, Less Mat, Only	2.10
386	WUALK	XK-2216	Footboard Hinge	.40
387	WUALO	K-584	Footboard, Complete, Right or Left	2.70
388	WUALT	K-124	Footboard Bolt	.10
389	WUABU	303-W	Footboard Bolt Washer	.01
390	WUAMB	204-N	Footboard Bolt Nut	.04
391	WUAMO	H-6473	Tool Box Clamp	.10
392	WODON	301-W	Tool Box Clamp Screw Lockwasher	.01
393	WUAMU	110-S	Tool Box Clamp Screw	.01
394	WUANA	F-2931	Tool Box, Complete, Less Tool Kit	2.50
395	WUAND	XK-4707	Oil Can	.30
396	WUANK	XK-1875	Chain Tool, Complete	.88
397	WUANS	XK-4706	Screw Driver	.45
398	WUANU	G-6102	Chain Repair Link and Connector	.45
399	WUANY	XG-2866	End Wrench, 3/4" Tappet	.15
400	WUAPE	G-6436	Double End Wrench	.30
401	WUAPH	K-1704	Wrench for Cylinder Valve Plug	.35
402	WUAPQ	XK-1877	Axle Wrench	.25
403	WUARA	XK-4705	Monkey Wrench	.95
404	WUARD	XK-4704	Pliers	.75

ELECTRICAL EQUIPMENT—(Plate VII)

405	WUARM	K-427	Horn Switch and Wiring, Complete	1.00
	WUARS	K-4513	Horn Switch Wire, Only	.15
	WUANS	K-4515	Horn Switch Cover	.15
	WUASE	K-4516	Horn Switch Lever	.06
	WUASX	K-4517	Horn Switch Metal Plate	.05
	WUASO	K-4518	Horn Switch Insulation (Two)	.04
	WUASU	K-4519	Horn Switch Insulation Bushing (Two)	.05
	WUATA	K-4521	Horn Switch Lever Buttons	.10
	WUATH	K-4522	Horn Switch Eyelet Brass	.01
	WUATI	K-4523	Horn Switch Rivet, Copper	.01
	WUAVO	K-4524	Horn Switch Washer, Brass	.01

ELECTRICAL EQUIPMENT—(Plate VII)

Photo No.	Code	Parts No.	NAME	Price
406	WUAWA	100-X	Horn Switch Screw.....	\$.42
407	WUOHO	300-W	Horn Switch Screw Washer.....	.01
408	WUAWS	K-786b	Horn, Complete.....	4.00
409	WUAWY	K-4666	Horn Bracket.....	.40
410	WUAXE	K-4667	Horn Bracket Clamp.....	.15
411	WUAXO	XK-2785	Horn Bracket Clamp Screw.....	.02
412	WODON	301-W	Horn Bracket Clamp Screw Lockwasher.....	.01
413	WUAXU	XK-3616	Horn Bracket Clamp Nut.....	.03
414	WOBZA	K- 406	Generator Belt, Endless.....	.50
	WUAYS	XK-3179	Generator Belt, Hook, Old Style.....	.01
415	WUAZU	K-4900	Generator.....	30.00
416	WUAZY	XK-2671	Generator Shaft Key.....	.03
417	WUBAJ	XK-3078	Generator Pulley.....	.75
418	WUBAK	XK-3908	Generator Pulley Lockwasher.....	.01
419	WUBAM	XK-3151	Generator Shaft Nut (Special).....	.05
420	WUBAR	K- 436	Magneto Wires, Complete, with Terminals (all the same length).....	.50
	WUBAT	K-4102	Magneto Wires, Snap Terminals.....	.10
421	WUBAV	K-4001	Magneto, Clockwise.....	50.00
422	WUBAX	H-6395	Magneto Cutout Switch.....	.20
423	WODON	301-W	Magneto Cutout Switch Washer.....	.01
424	WUBBY	H-6397-A	Magneto Cutout Switch Nut.....	.15
425	WUBCA	Xk-4784	Tail Light, Ruby Glass.....	.18
426	WUBCI	XK-4785	Tail Light, Ruby Glass, Retaining Ring.....	.05
427	WUBDE	XK-4782	Tail Light and License Bracket, Complete.....	2.00
	WUBDO	XK-4786	Tail Light Glass Cup or Cylinder.....	.30
428	WUBDU	XK-4804	Tail Light Bulb.....	.28
429	WUBEH	XK-4806	Tail Light Connector Plug.....	.60
430	WUBEC	XK-4734	Tail Light Bracket Screw.....	.03
431	WODAL	302-W	Tail Light Bracket Screw Lockwasher.....	.01
432	WUBEL	XK-1525	Tail Light Bracket Screw Nut.....	.05
433	WUBEM	K-4814	Tail Light Wire.....	.20
434	WUBEP	HK-7085	Tail Light Wire Plug.....	.10
435	WUBFS	K-4823	Tail Light Wire Casing, Rubber Hose.....	.45
436	WUBEW	K-4822	Tail Light Wire Casing, Copper Tube.....	.35
437	WUBFI	XK-3610	Tail Light Casing Clip to Guard Screw Nut.....	.03
438	WODON	301-W	Tail Light Casing Clip to Guard Screw Lockwasher.....	.01
439	WUBGA	H-7074	Tail Light Casing Clip.....	.06
440	WUBGI	XK-2785	Tail Light Casing Clip Screw.....	.02
441	WUBGY	HK-7092	Trouble Light Plug Base Insulator.....	.05
442	WUBHO	HK-7086	Trouble Light Plug Base Insulator.....	.35
443	WUBHU	HK-7087	Trouble Light Plug Base Cover.....	.15
444	WUBID	7093-X	Trouble Light Plug Base Plate and Socket.....	.20
445	WUBIJ	175-S	Trouble Light Plug Base Screw.....	.02
446	WUBIK	100-X	Trouble Light Plug Cover Screw.....	.02
447	WUBIN	200-N	Trouble Light Plug Cover Nut.....	.01
448	WUBIR	173-S	Trouble Light Plug Base Plate Screw.....	.02
449	WUBIT	XK-4503	Headlight Bulb, Large.....	.65
450	WUBIX	XK-4504	Headlight Bulb, Dimmer.....	.28
451	WUBIZ	B-6926	Headlight Connector Plug and Switch.....	.75
452	WUBJO	XK-4781	Headlight, Complete.....	7.00
	WUBJU	XK-4780	Headlight Monogram, Lens Only.....	.50
453	WUBKE	K-471b	Headlight Bracket, Left, with Nuts.....	.75
454	WUBKO	K-4709	Headlight Bracket, Right, with Nuts.....	.75
455	WUBKD	207-N	Headlight Bracket Nut.....	.05
456	WOCMO	304-W	Headlight Bracket Lockwasher.....	.01
457	WUBLY	K- 745	Ammeter, Complete with Bracket.....	5.00
	WUBME	K-7050	Ammeter, Only.....	4.50
458	WUBMO	K-7051	Ammeter Bracket, Only.....	.30
459	WODON	301-W	Ammeter Bracket Screw Lockwasher.....	.01
460	WUBNI	109-S	Ammeter Bracket Screw, to Frame.....	.03
461	WUBNY	173-S	Wiring Terminal End Connecting Screw.....	.02
462	WUBOB	200-N	Wiring Terminal End Connecting Screw Nut.....	.01
463	WUBOC	XK-4783	Battery.....	15.00
464	WUBOF	XK-3182	Black Rubber Tubing.....	.05
465	WUBOG	XK-3183	Black Rubber Tubing.....	.05
466	WUBOL	XK-4418	Short Rubber Nipples for Terminal Connectors.....	.02
467	WUBOM	K-4490	Switch Box Fuse Wire Connector.....	.01
468	WUBOP	XK-4089	Fuse Block Screw.....	.02
469	WUBOS	XK- 412	Fuse Block, Complete.....	.34
470	WUBPO	XK-4085	Fuse, Only.....	.10
471	WUBRU	XK-4082	Switch Box Cover.....	.35
472	WUBSE	XK-4095	Switch Box Cover Screw.....	.05
473	WUBSO	XK-4092	Cuder-Hammer Switch.....	1.00
474	WUBSU	XK-4421	Battery Box Filler Block, Top.....	.05
475	WUBTA	XK-4423	Battery Box Filler Block, Back.....	.10
476	WURTI	XK-4422	Battery Box Filler Block, Side.....	.10
477	WUBTY	XK-3180	Black Rubber Tubing.....	.10

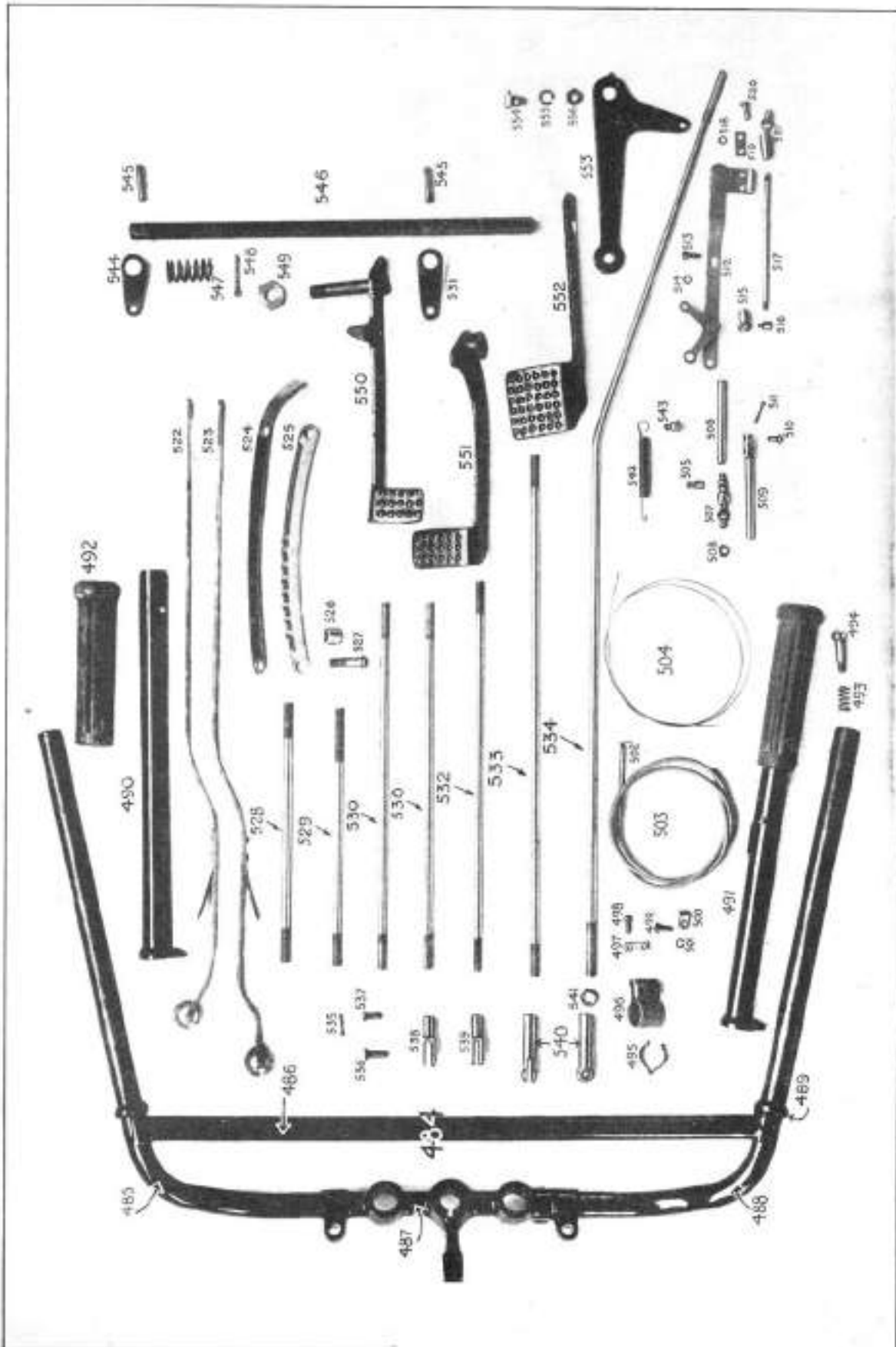

VIII—HANDLEBARS AND CONTROL PARTS

ELECTRICAL EQUIPMENT— (Plate VII)

Photo No	Code	Para No.	NAME	Price
478	WUBUB	149-S	Battery Box Clip Screw	\$.04
479	WUBUC	XK-1525	Battery Box Clip Screw Nut	.05
480	WUBUG	176-S	Battery Box Cover Screw	.02
481	WOOHO	300-W	Battery Box Cover Screw Lockwasher	.01
482	WUBUM	202-N	Battery Box Cover Screw Nut	.03
	WUBUP	K-4408	Battery Box Cover Screw Plate, New Style (Superalex 202)	.10
483	WUBUS	K- 454	Battery Box, Complete, with Switch Box Base	6.15
	WUCAT	K- 422	Battery Box, Complete, with Switch and Wiring	10.00
	WUBMU	K-4406	Battery Box, Cover	.60
	WUCAJ	K-4401	Switch Box, Base only	.25
	WUCAK	K-4129	Switch Box Eyelet (Electrical Wiring, not mounted)	.01
	WUCAN	K- 421	Switch Box, Complete, with Wires	2.75
	WUCAR	K- 419	Set of Wiring, Complete, less Switch Box	1.30
	WUCAX	XK-3185	Copper Wiring Terminals	.02
	WUCAZ	K-4413	Battery to Ammeter Wire	.20
	WUCBA	K-4415	Fuse Block to Battery Wire	.15
	WUCBI	K-4613	Main Switch to Horn Wire	.15
	WUCBY	K-4213	Main Switch to Headlight Wire	.20
	WUCCA	K-4913	Generator to Battery Wire	.20

HANDLEBARS AND CONTROL PARTS— (Plate VIII)

	WUDCE	K- 639	Handlebar Complete with Sleeves and Grips	26.50
484	WUDCO	K- 638	Handlebar Only	16.00
485	WUDCU	K-6405	Handlebar Tube, Right Side	1.60
486	WUDDI	K-6403	Handlebar Cross Bar	1.05
487	WUDED	K-6400	Handlebar Yokes	5.25
488	WUDEH	K-6406	Handlebar Tube, Left Side	1.60
489	WUDEJ	K-6421	Handlebar Sleeve Collar	.60
490	WUDEK	K- 635	Handlebar Sleeve, Right Only	1.65
491	WUDEN	K- 636	Handlebar Sleeve, Only, Left	1.65
492	WUDEN	XK-4235	Handlebar Grip, Only	.75
493	WUDET	K-6425	Handlebar Sleeve Screw Spring	.05
494	WUDEX	K-6424	Handlebar Sleeve Screw	.05
495	WUDFE	K-5450	Handlebar Strap Clip	.06
496	WUDFU	K-5407	Handlebar Control Casing Clip	.10
497	WUDGE	K-5451	Handlebar Control Casing Clip Plate	.12
498	WUDGU	106-S	Handlebar Control Casing Clip Screw	.02
499	WUDGV	106-S	Control Casing Clip to Frame Screw	.02
500	WUDHA	H-2085	Control Casing Clip to Frame	.03
	WUDHH	K-1294	Control Casing Clip Base for attaching to Front Exhaust Pipe	.03
501	WUDON	301-W	Control Casing Clip to Frame Screw Lockwasher	.01
502	WUDIB	K-2075	Control Casing Clevis Sleeve Inside	.12
503	WUDIC	K-5401	Throttle or Magneto Control Casing Only	.25
504	WUDIE	K-5413	Throttle or Magneto Control Wire	.10
505	WUDIG	A-2021	Control Wire Clevis Set Screw	.07
506	WUDIM	H-2074	Control Ball Joint Sleeve, Only..	.15
507	WUDIP	K- 544	Control Ball Joint Only	.24
508	WUDIS	214-N	Control Ball Joint Nut	.05
509	WUDIY	H-2087	Control Clevis Sleeve, Only, Lower End	.15
	WUDJA	H-2088	Control Wire, Clevis, Only, Lower End	.35
510	WUDJJ	H-2105	Control Clevis Pin	.06
511	WUDKA	K- 601	Control Clevis Pin, Crater Pin	.01
	WUDKJ	K- 572	Carburetor to Magneto Control, Complete	1.45
512	WUDTU	K- 542	Magneto Control Bell Crank and Bracket, Complete	.45
513	WUDUD	106-S	Magneto Bracket Screw to Cylinder	.02
514	WUDON	301-W	Magneto Control Bracket Screw Lockwasher	.01
515	WUDUK	XK-4441	Magneto Spark Advance Rod End	.25
516	WUDUN	XK-4331	Magneto Spark Advance Rod End Threaded Rivet	.03
517	WUDUR	K-5411	Magneto Spark Advance Rod	.10
518	WUDON	301-W	Magneto Bracket Clamp Plate Screw Washer	.01
519	WUDUV	K-5451	Magneto Bracket Clamp Plate	.12
520	WUDUX	106-S	Magneto Bracket Clamp Plate Screw	.02
521	WUEBA	K- 548	Magneto Spark Advance Rod Ball Joint	.25
522	WUEBS	K- 639	Clutch or Reverse Gear Hand Lever, New Style, Low Frame	1.60
523	WUEBY	K- 538	Gear, Shifter Hand Lever, Complete, New Style, Low Frame	2.80
	WUDUJ	K- 536	Gear Shifter Lever, High Frame, 4-gal. Tank	2.80
	WUDUT	K- 537	Clutch or Reverse Shifter Lever, High Frame, 4-gal. Tank	1.60
	WUBUL	B-1602	Gear Shifter Hand Lever Catch Spring	.10
	WUBMU	C-6581	Gear Shifter Hand Lever Flat Spring	.10
524	WUECA	K-5299	Quadrant Outside Flute	.50
525	WUECI	K-5278	Gear Shift Lever Quadrant	.75
526	WUECS	G-6388	Gear Shift Quadrant Screw Spacer	.05
527	WUECY	G-6327	Gear Shift Quadrant Screw	.25
	WUEDE	K-1529	Gear Shift Quadrant Support to Tank	.60

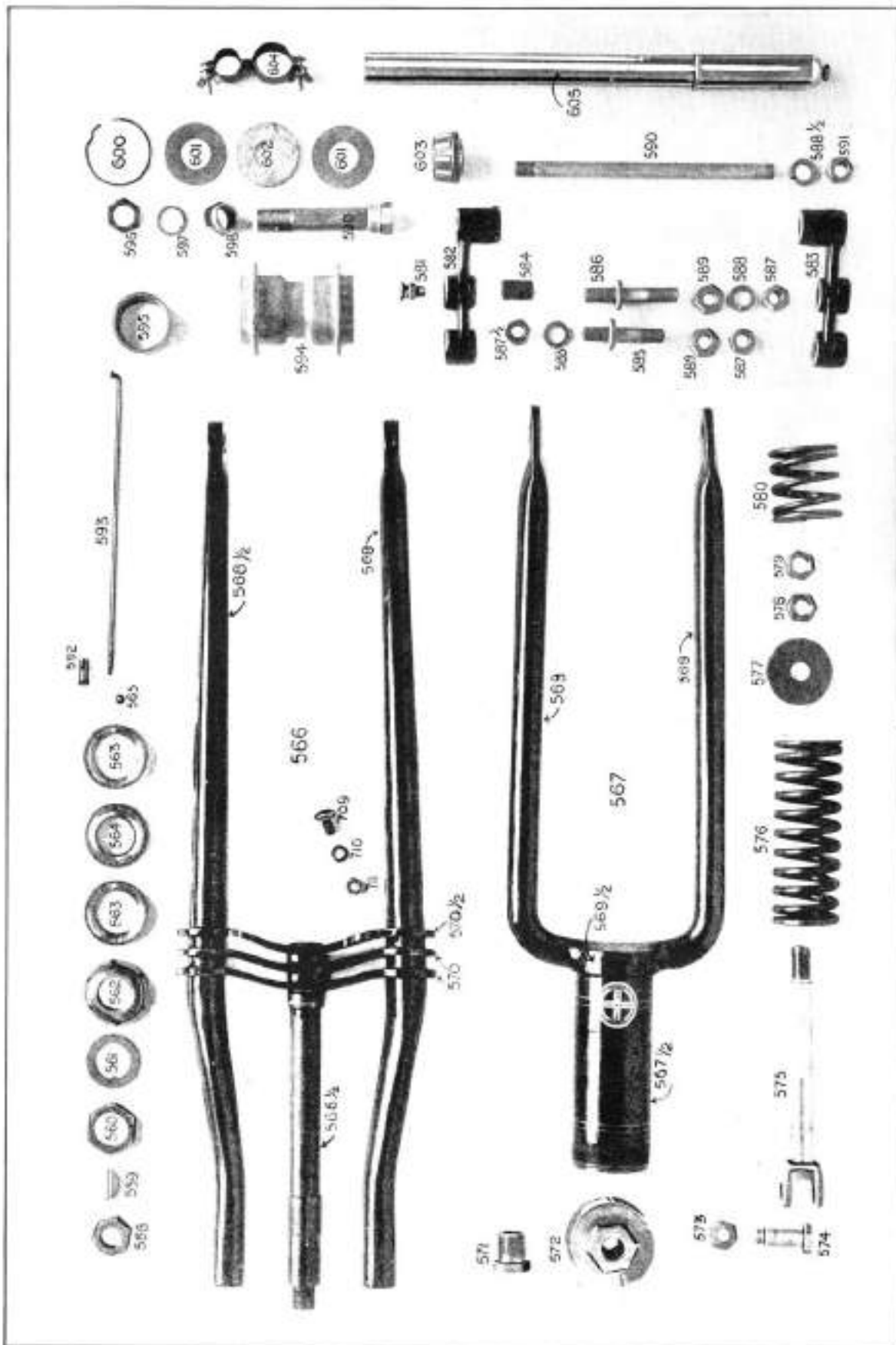

IX—FORK AND FRONT WHEEL PARTS

HANDLEBARS AND CONTROL PARTS—(Plate VIII)

Photo No.	Code	Parts No.	NAME	Price
528	WUEDO	K-5512	Clutch Release Rod.....	.25
529	WUEDU	K-5639	Brake Rod Rear.....	.25
530	WUEFA	K-5902	Reverse Shifter Rod.....	.38
531	WUEFY	K-5688	Brake Lever, Long.....	.60
532	WUEGA	K-5316	Gear Shifter Rod.....	.38
533	WUEGH	K-5657	Brake Rod Front.....	.40
534	WUEGI	K-5562	Internal Brake Rod.....	.70
535	WUEGN	2607	Clevis Pin, Cotter Pin.....	.01
536	WUEHE	K-5559	Brake Clevis Pin, Long.....	.15
537	WUEHL	3732	Brake Clevis Pin, Short.....	.05
538	WUEHM	G-1401	Clutch Lever Clevis.....	.35
539	WUEHO	K-5320	Control Clevis.....	.35
540	WUEHU	K-5577	Brake Rod Clevis.....	.50
541	WUEJE	207-N	Clevis Lockout.....	.05
542	WUEJO	K-5561	Brake Pedal Return Spring.....	.15
543	WUEJU	K-5560	Brake Pedal Spring Stud.....	.20
544	WUEKA	K-5484	Brake Lever, Short.....	.45
545	WUEKI	K-5482	Brake Lever, Taper Pin.....	.04
546	WUEKB	K-5496	Brake Shift.....	.45
547	WUEKY	H-4466	Brake Shift Spring.....	.08
548	WUELA	K-5680	Brake Shift Cotter Pin.....	.01
549	WUELF	K-5504	Clutch and Brake Pedal Lockout.....	.10
550	WUELI	K-551	Clutch Pedal and Fulcrum Bolt Assembly.....	1.70
	WUELK	K-551-A	Clutch Pedal for Machines with Reverse.....	1.10
	WUELP	K-5500	Clutch Pedal, Only.....	.80
551	WUELS	K-561	Brake Pedal Assembly.....	.80
552	WUELY	K-5551	Internal Brake Pedal, Only.....	.35
553	WUEMA	K-5550	Internal Brake Foot Lever.....	.50
554	WUEMI	K-5554	Internal Brake Pedal Fulcrum.....	.15
555	WUEMS	K-3908	Internal Brake Pedal Fulcrum Lockwasher.....	.01
556	WUEMY	K-5557	Internal Brake Pedal Fulcrum Nut.....	.10

FORK AND FRONT WHEEL PARTS—(Plate IX)

	WUCOB	K-600	Front Fork Assembly Complete.....	55.00
558	WUCCI	K-6005	Front Fork Main Stem Nut.....	.30
559	WUCDE	K-6013	Front Fork Main Stem Key (No. 13).....	.04
560	WUCDO	XK-2048	Front Fork Main Stem Adjusting Cone Locknut.....	.35
561	WUCDU	XK-2007	Front Fork Locknut Washer.....	.10
562	WUCEC	XK-2565	Front Fork Main Stem Adjusting Cone.....	.80
563	WUCEF	XK-2564	Frame Head Caps Top and Bottom.....	.75
564	WUCEG	XK-2566	Fork Main Stem Stationary Cone.....	.35
565	WUCEL	XK-2037	Fork Main Stem Bearing Ball, 1/4".....	.01
566	WUCFM	K-600	Front Fork, Main Assembly.....	17.25
566 1/2	WUCEP	K-6000	Front Fork, Stem.....	1.90
567	WUCES	K-670	Spring Fork, Assembly.....	8.25
567 1/2	WUCEW	K-6707	Spring Fork, Barrel.....	1.50
568	WUCFI	K-6001	Main Fork Blade, Right.....	4.10
568 1/2	WUCFY	K-6002	Main Fork Blade, Left.....	4.10
569	WUCGI	K-6701	Spring Fork Blade, Right or Left.....	2.80
	WUCGY	K-6007	Main Fork Crown Collar (Two).....	.15
	WUCHE	K-6014	Main Fork Stem Spacer.....	.10
569 1/2	WUCHO	K-6700	Spring Fork Crown.....	3.00
570	WUCHU	K-6009	Main Fork Crown, Upper Plates.....	.50
570 1/2	WUCIU	K-6009	Main Fork Crown, Bottom Plate.....	.50
571	WUCIJ	XK-2634	Cap Screw Holding Handlebars to Fork.....	.25
572	WUCIK	K-6708	Front Fork Spring Barrel Cap.....	2.00
573	WUCIN	A-2041	Front Fork Clevis Bolt Nut, 1/2" x 20.....	.15
574	WUCIR	A-2040	Front Fork Clevis Bolt.....	.55
575	WUCIZ	K-6460	Front Fork Spring Fork Clevis.....	2.00
576	WUCJE	K-6447	Front Fork Main Spring, Long.....	2.00
577	WUCJO	K-6449	Front Fork Washer for Main Spring.....	.15
578	WUCJU	228-N	Front Fork Clevis Nut.....	.15
579	WUCKE	K-6429	Front Fork Clevis Locknut.....	.05
580	WUCKO	K-6646	Front Fork Rebound Spring, Short.....	1.35
581	WUCKU	B-1585	Front Fork Rocker Arm Oil Cup, Large.....	.25
	WUCKX	XK-1443	Front Fork Rocker Arm Oil Cup, New Style, Small.....	.25
582	WUCLI	K-6704	Front Fork Rocker Arm, Left.....	1.50
583	WUCLY	K-6703	Front Fork Rocker Arm, Right.....	1.50
584	WUCMR	K-6705	Front Fork Rocker Arm, Bushing.....	.20
585	WUCMU	K-6706	Front Fork Rocker Arm, Stud, Short.....	.30
586	WUCNA	K-6716	Front Fork Rocker Arm, Stud, Long.....	.33
587	WUCNI	276-S	Front Fork Rocker Arm, Stud Nut, outside, Small Diameter.....	.10
587 1/2	WUCNY	210-N	Front Fork Rocker Arm, Stud, Nut, Inside.....	.05
588	WUENG	306-W	Front Fork Rocker Arm, Stud, Lockwasher.....	.03
588 1/2	WUCOC	K-6710	Front Axle Lockwasher.....	.05
589	WUCOF	226-L	Front Fork Rocker Arm Stud Nut, Outside, Large Diameter.....	.10

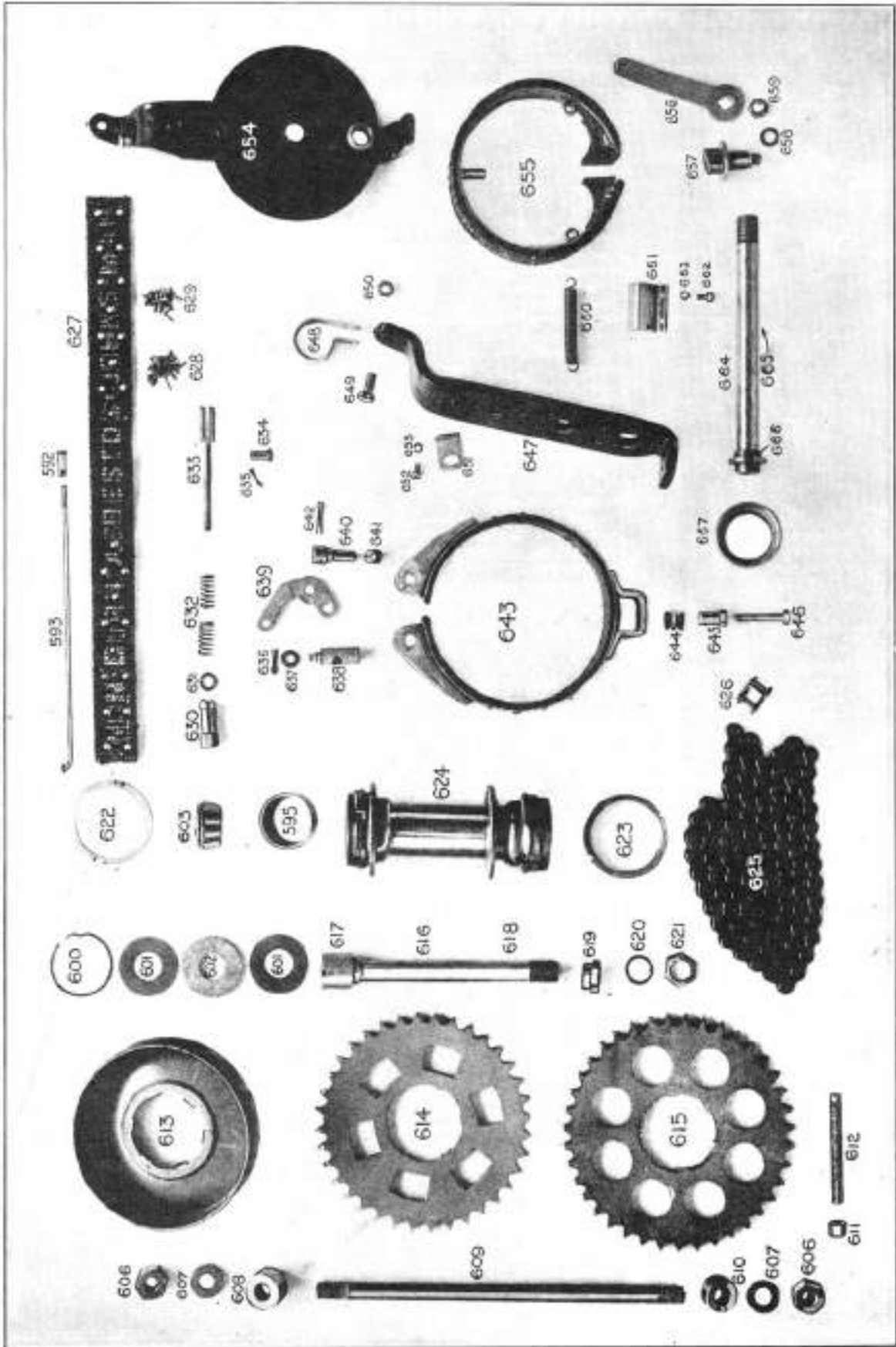

X—BRAKE AND REAR WHEEL PARTS

FORK AND FRONT WHEEL PARTS—(Plate IX)

Photo No.	Code	Parts No.	NAME	Price
500	WUCOO	K-7891	Front Axle	\$.30
501	WUCOL	H-2404	Front Axle Nut.....	.10
502	WUCOM	K-7509	Front and Rear Spoke Nipple02
503	WUCOS	K-7508	Front and Rear Spoke (40)64
	WUENR	K- 740	Front Wheel Complete, less Tire	15.30
	WUCPE	K- 743	Front Hub Complete, Timken	8.50
504	WUCPO	K-7402	Front Hub Shell Only.....	5.15
505	WUCRU	K-8020	Front or Rear Hub, Timken Roller-Bearing Cup, Only40
506	WUCSE	K-8014	Front Hub Quill, Adjusting Locknut15
507	WUCSO	K-8006	Front Hub Quill, Adjusting Lockwasher04
508	WUCSU	K-8013	Front Hub Quill, Adjusting Nut15
509	WUCTA	K- 743	Front Hub Quill, Complete with Spacer	1.30
	WUCTI	K-7403	Front Hub Quill, Only50
	WUCTY	K-7404	Front Hub Quill, Spacer Only30
600	WUCUC	K-8010	Front or Rear Hub, Snap Spring (Two)04
601	WUCUF	K-8009	Front or Rear Hub, Dust Washer (Four)05
602	WUCUG	K-8008	Front or Rear Hub Felt Washer (Two)05
603	WUCUL	K-8021	Front or Rear Hub Timken Bearing, Cone, Retainer and Rollers, Only75

BALL-BEARING FRONT AND SIDECAR HUBS (Not Illustrated)

	WUCUM	K- 731-A	Front Hub, Complete.....	6.00
	WUCUP	K- 731	Front Hub Shell with Cups	3.60
	WUCUS	H-2418	Front Hub Ball Cup.....	.60
	WUDAF	K- 243	Front Hub Cone.....	.60
	WUDAG	K-2426	Front Hub Cone Ball Retaining Ring.....	.10
	WUDAL	K-2421	Front Hub Cone Felt Washer.....	.05
	WUDAP	K-2420	Front Hub Cone Felt Washer Retainer and Locking Cap.....	.05
	WUDAS	H-2405	Front Hub Quill.....	.60
	WUDAW	H-2410	Front Hub Axle Quill Locknut15
	WUDAY	H-2409	Front Hub Quill Lockwasher.....	.05
	WUDBE	XK-3863	Front Hub Steel Balls 3/4" (20).....	.04
604	WUDBO	2476	Tire Pump Clip.....	.10
605	WUDBU	XK-4749	Tire Pump, Complete with Hose.....	1.25

REAR WHEEL AND BRAKE PARTS—(Plate X)

606	WUENT	XK-3792	Rear Axle Nut.....	.15
607	WUEPA	XK-3791	Rear Axle Washer.....	.10
608	WUEPI	K-8792	Rear Axle Spacer Wide (Left)25
609	WUEPS	K-8901	Rear Axle.....	.90
610	WUEPT	K-8791	Rear Axle Spacer Narrow (Right)25
611	WUEPU	4358	Chain Adjusting Screw Nut (5/16")06
612	WUERB	K-8902	Chain Adjusting Screw (5/16").....	.20
	WUERE	K-8891	Chain Adjusting Screw (3/4")15
	WUERK	214-N	Chain Adjusting Screw Nut (1/2").....	.05
613	WUERL	K- 621	Brake Drum.....	2.85
614	WUERT	K-8942	Rear Sprocket, 36 teeth	4.75
615	WUERU	K-8943	Rear Sprocket, 39 teeth	5.00
616	WUERY	K- 820	Rear Wheel Quill with Spacer, Assembled, Left Thread	1.50
617	WUESH	K-8004	Rear Wheel Quill Spacer Only30
618	WUEST	K-8003	Rear Wheel Quill Only	1.20
619	WUESY	K-8018	Rear Axle Quill Adjusting Nut, Left Thread15
620	WUETE	K-8006	Rear Axle Quill Adjusting Lockwasher04
621	WUETS	K-8019	Rear Axle Quill Adjusting Locknut, Left Thread15
622	WUETU	XK-3854	Rear Hub Brake Drums Locknut50
623	WUEVS	XK-3794	Rear Hub Sprocket Locknut.....	.65
624	WUEVY	K- 811	Rear Hub Shell with Timken Cups, Only	6.90
	WUEWO	K- 815	Rear Hub Assembly Timken Bearings, Complete, less Sprocket and Drum	15.00
	WUEWU	K- 818	Timken Conversion Set to Change Old Type Ball Bearing Rear Hubs to Timken Bearing Style.....	7.15
	WUEXA	K- 813	Rear Wheel, Complete without Tire	35.00

PARTS FOR OLD STYLE BALL-BEARING REAR HUBS (Not Illustrated)

	WUEXS	K- 804	Rear Hub Complete, less Sprocket and Drum	15.00
	WUEYE	K- 801	Rear Hub Shell with Ball Cups	6.90
	WUEYO	XK-3851	Rear Hub Shell Ball Cup, Only60
	WUEZI	XK-3793	Rear Hub Cone, Left75
	WUEAD	XK-3860	Rear Hub Cone, Right, with Dust Cap.....	1.20
	WUEAK	XK-3852	Rear Hub Cone, Dust Washer, Right.....	.14
	WUEAN	XK-3855	Rear Hub Cone, Dust Washer, Left10
	WUEAR	K-8891	Rear Axle90
	WUEAT	XK-3792	Rear Axle Nut15
	WUEAV	XK-3791	Rear Axle Washer10
	WUEAX	XK-3785	Rear Axle Quill	1.20
	WUEAZ	XK-3873	Rear Axle Quill Washer.....	.02

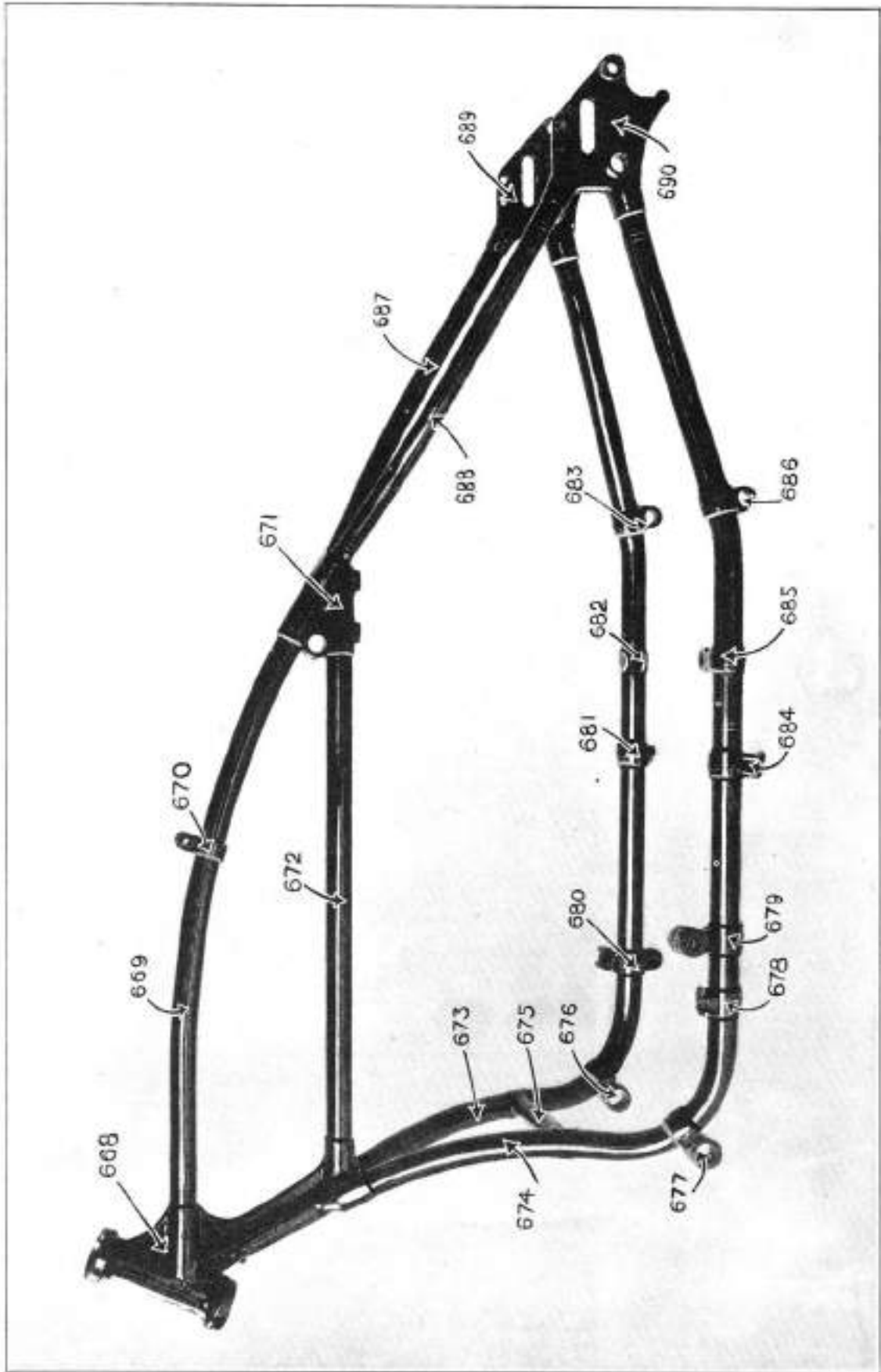

XI—FRAME

REAR WHEEL AND BRAKE PARTS—(Plate X)

Photo No.	Code	Parts No.	NAME	Price
	WUFBA	X K-3788	Rear Axle Quill Lockwasher	\$.05
	WUFABY	X K-3789	Rear Axle Quill Locknut	.10
	WUFCA	K-8790	Rear Axle Spacers, Left	.35
	WUFCL	K-8791	Rear Axle Spacers, Right	.25
	WUF(IDE)	X K-3786	Rear Axle Steel Balls, 7/16" (22)	.65
	WUFDO	X N-3854	Rear Axle Right Cam Lock Pin	.02
625	WUFDU	K-8100	Roller Chain, 92 Links, 3/4" x 1/2" Pitch	6.00
626	WUFER	XX-3224	Roller Chain, Connecting Link Only	.25
	WUJANQ	G-6102	Chain Repair Link and Connector	.45
	WUFRF	XK-3295	Chain Repair Half Link	.40
	WUFEG	XK-3296	Chain Repair Roller Link, Only	.20
	WUFEP	G-6106	Chain Repair Lock Spring Clip	.02
	WUFES	K- 629	External Brake Band Assembly with Fastangs	4.75
627	WUFEW	K-6232	External Brake Lining, Only	1.50
628	WUFFI	XK-3848	External Brake Lining, Long Rivets (12)	.01
629	WUFFY	XK-3846	External Brake Lining, Short Rivets (14)	.01
630	WUFGA	K-6253	External Brake Lining Adjusting Pin Nut	.30
631	WUEGI	4397	External Brake Clevis Spring Washer	.03
632	WUFGY	K-6265	External Brake Clevis Spring	.10
633	WUFHE	K-6249	External Brake Adjusting Clevis	.35
634	WUFHO	1858	External Brake Clevis Pin	.06
635	WUFID	2607	External Brake Clevis Pin, Cotter Pin	.01
636	WUFIJ	2607	External Brake Adjusting Pin, Cotter Pin	.01
637	WUFIK	K-6247	External Brake Adjusting Pin Washer	.03
638	WUFIN	K-6252	External Brake Adjusting Pin	.20
639	WUFIR	K-6248	External Brake Lever	.35
640	WUFIT	K-6245	External Brake Lever Pin	.15
641	WUFIX	K-6244	External Brake Lever Pin Spacer	.06
642	WUFIZ	K-6270	External Brake Lever Pin, Cotter Pin	.01
643	WUFJE	K- 627	External Brake Band, with Lining less Fastangs	3.50
	WUFJO	K-6262	External Brake Band, Only	.65
	WUFKE	K-6240	External Brake Band, End Supports (Two)	.40
	WUFKO	K-6263	External Brake Band, Anchor	.25
644	WUFKU	K-6249	External Brake Band, Adjusting Spring	.10
645	WUFLT	K-6267	External Brake Band, Adjusting Locknut	.15
646	WUFLY	K-5502	External Brake Band, Adjusting Bolt	.15
647	WUFMR	K-6260	Brake Plate Arm	1.50
648	WUFMO	K-4402	Brake Plate Arm Clip	.10
649	WUFMU	K- 120	Brake Plate Arm Clip Bolt	.10
650	WUFNA	K- 204	Brake Plate Arm Clip Bolt Nut	.04
651	WUFNI	K-6264	External Brake Clevis Guide	.25
652	WUFNB	173-S	External Brake Clevis Guide Screw (Two)	.02
653	WODDN	301-W	External Brake Clevis Guide Screw Lockwasher (Two)	.01
	WUFOP	K- 617	External Brake Assembly, Complete less Drum	10.00
654	WUFOG	K- 619	Brake Plate Assembly (Used Only with Internal Brake)	3.20
	WUFOC	K- 641	Internal Brake Assembly, Complete	10.75
655	WUFOL	K- 623	Internal Brake Band Assembly	5.40
656	WUFOM	K-6222	Internal Brake Lever	.50
657	WUFOP	K-6276	Internal Brake Cam	1.00
658	WUFOS	3739	Internal Brake Cam Lockwasher	.02
659	WUFPE	3636	Internal Brake Cam Nut	.10
660	WUFPO	K-6215	Internal Brake Band Return Spring	.15
661	WUFSE	K-6278	Internal Brake Cam Stop	.12
662	WUFSO	K-6229	Internal Brake Cam Stop Screw	.02
663	WODDN	301-W	Internal Brake Cam Stop Screw Lockwasher	.01
	WUFSU	K-6217	Internal Brake Cam Washer	.30
	WUFEC	K-6277	Internal Brake Cam Bushing	.35
664	WUFTA	K- 819	Special Quill Assembly for Replacing Ball Bearings with Timken Bearings in Rear Hubs (See Timken Conversion Set K-818 after No. 624).	1.50
665	WUFTI	K-8012	Special Quill, Only	1.20
667	WUFUB	K-8011	Adapter Cup for Installing Timken Bearings in Old Style Ball Bearing Hubs	1.34

FRAME ASSEMBLY—(Plate XI)

	WUFUC	K- 502	Frame Assembly, Complete (New Style Low Saddle Position)	70.00
	WUGEL	K- 501	Frame Assembly, Old Style (High Saddle)	70.00
668	WUFUP	K-5000	Frame Head	} Price on Application
669	WUFUG	K-5161	Frame Upper Tube	
670	WUFUM	K-5037	Frame Saddle Pivot Stamping	
671	WUFUP	K-5010	Frame Rear Stay Crown	
672	WUFUS	K-5166	Frame Center Tube	
673	WUGAJ	K-5162	Frame Bottom Tube, Right	

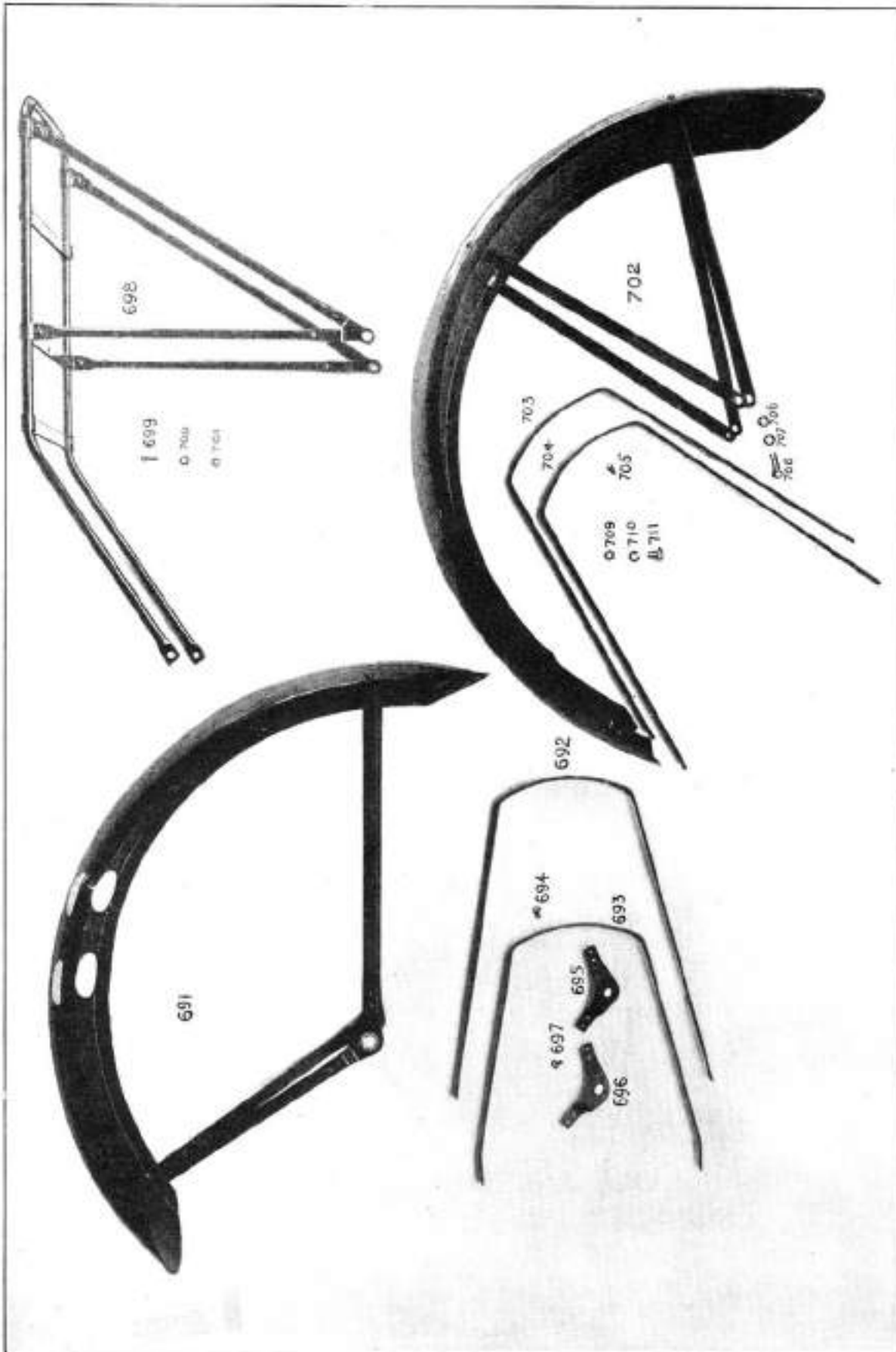

XII—MUDGUARDS AND LUGGAGE CARRIERS

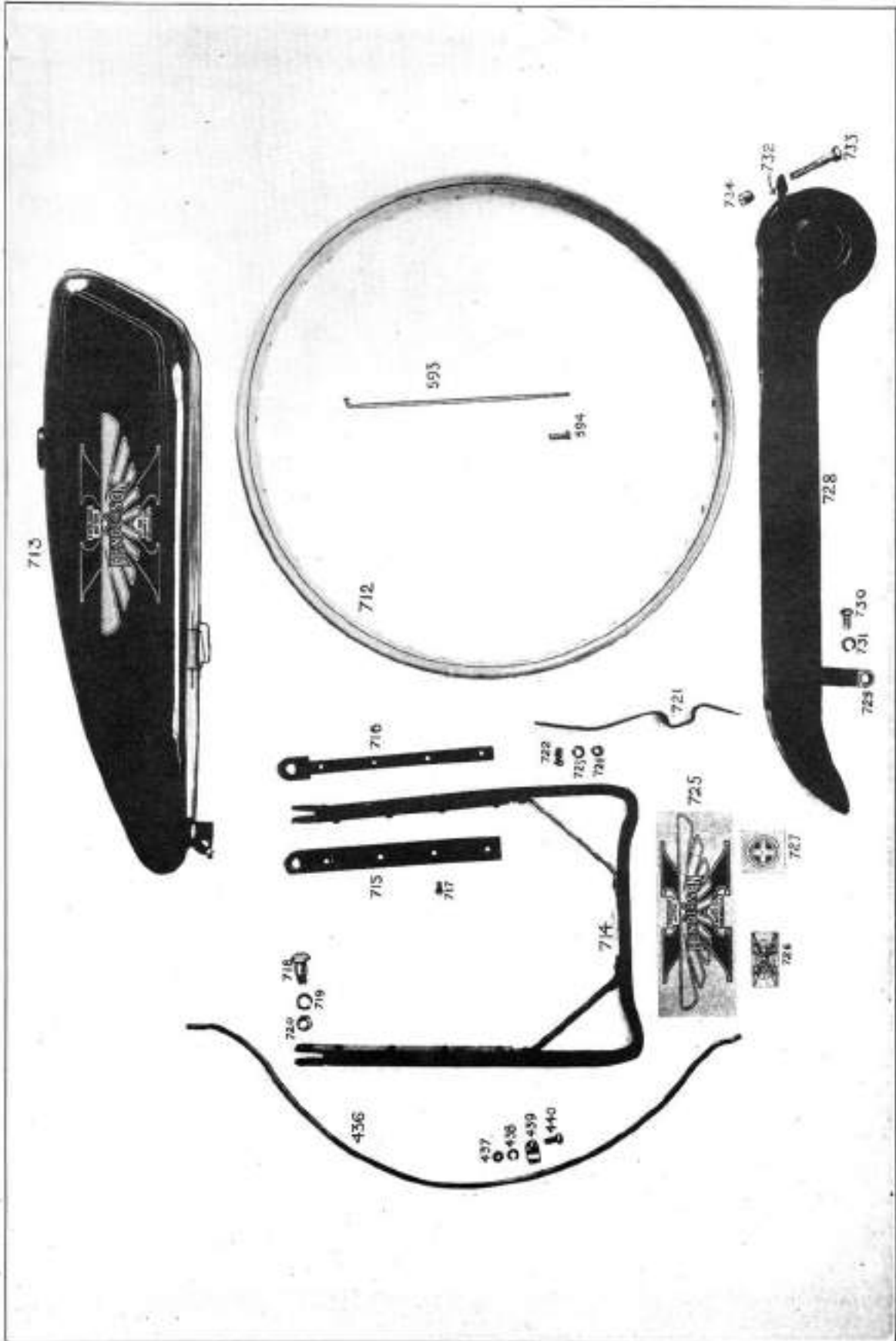

XIII—RIM, TANK, CHAIN GUARD AND STAND

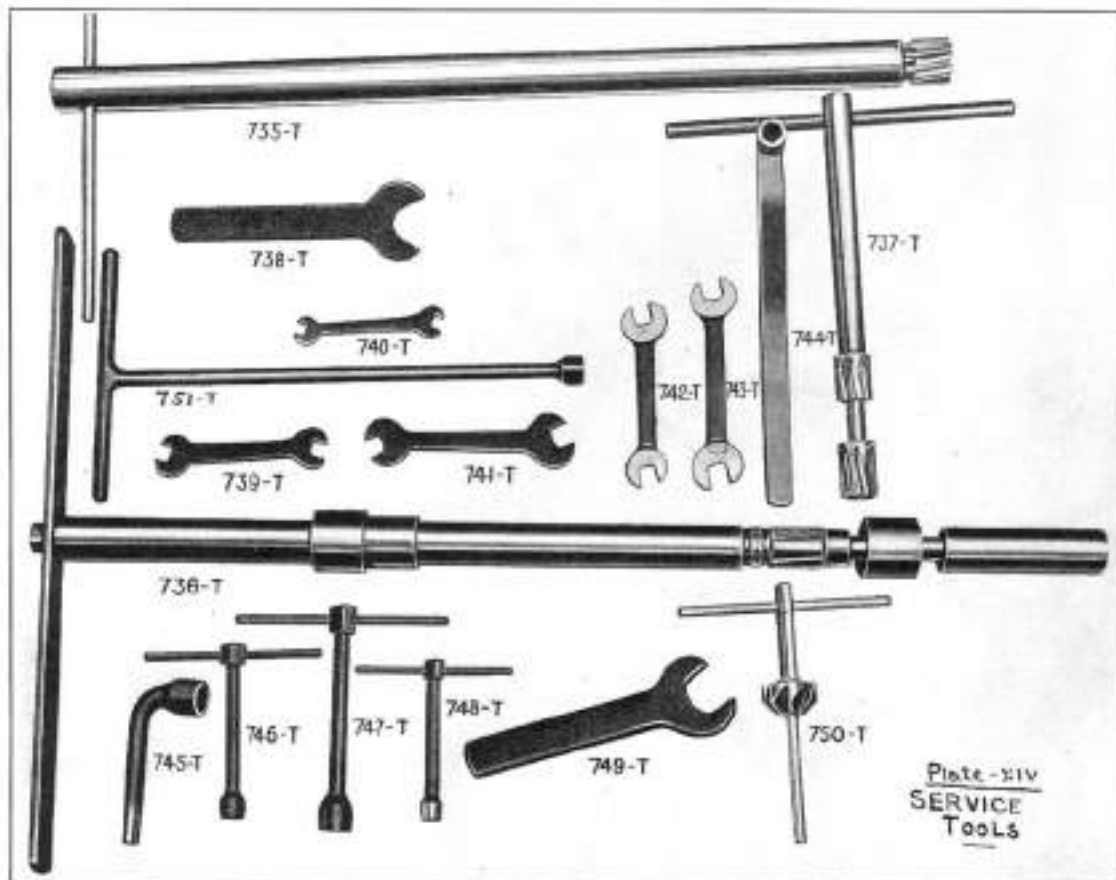

FRAME—(Plate XI)

Photo No.	Code	Parts No.	NAME	Price
674	WUGAK	K-5187	Frame Bottom Tube, Left	} Prices on Application
675	WUGAM	K-5191	Frame Front Stay Tube	
676	WUGAR	K-5024	Frame Front Lug, Right	
677	WUGAT	K-5025	Frame Front Lug, Left	
678	WUGAV	K-5021	Frame Foot Board Support, Left Front	
679	WUGAX	K-5026	Frame Clutch Pedal Bracket	
680	WUGBA	K-5020	Frame Footboard Support, Front Right	
681	WUGBI	F-2970	Frame Footboard Support, Rear Right	
682	WUGBY	K-5146	Frame Motor Lug	
683	WUGCA	K-5058	Frame Brake Shaft Support, Right	
684	WUGCI	E-2971	Frame Footboard Support, Rear Left	
685	WUGDE	K-5146	Frame Motor Lug	
686	WUGDO	K-5059	Frame Brake Shaft Support, Left	
687	WUGDU	K-5172	Frame Rear Stay Tube	
688	WUGEB	K-5172	Frame Rear Stay Tube	
689	WUGEC	K-5008	Frame Rear Axle Support	
690	WUGEG	K-5008	Frame Rear Axle Support	

MUDGUARDS AND LUGGAGE CARRIER—(Plate XII)

691	WUGEM	K- 680	Front Mudguard Assembly, Complete	\$ 5.85
692	WUEP	K-6805	Front Mudguard, Lower Brace	.35
693	WUGES	K-6806	Front Mudguard, Upper Brace	.40
694	WUGEW	2927	Front Mudguard, Brace Rivets	.01
695	WUGFI	K-6807	Front Mudguard Clip, Right	.10
696	WUGFY	K-6808	Front Mudguard Clip, Left	.10
697	WUGGA	3306	Front Mudguard Clip Rivet	.01
698	WUGGI	K- 590	Luggage Carrier Assembly	5.00
699	WUGHE	4734	Luggage Carrier Screw	.03
700	WODAL	392-W	Luggage Carrier Screw Lockwasher	.01
701	WUGHU	1525	Luggage Carrier Screw Nut	.05
702	WUGID	K- 575	Rear Mudguard Assembly, New Style for Low Saddle Position Frame, will not fit Old Type Frame with High Saddle Position	6.70
	WUGIJ	K- 574	Rear Mudguard Assembly, Old Style for Machines with High Saddle Position	6.70

Photo No.	Code	Part No.	NAME	Price
703	WUGIK	K-5573	Rear Mudguard Brace, Lower	\$.50
704	WUGIN	K-5576	Rear Mudguard Brace, Upper50
705	WUGIR	2927	Rear Mudguard Rivet01
706	WUGIT	2289	Rear Mudguard Brace Bolt10
707	WUGIX	3908	Rear Mudguard Brace Bolt Lockwasher01
708	WUGJE	204-N	Rear Mudguard Brace Bolt Nut04
709	WUGTY	204-N	Front or Rear Mudguard Bolt Nut04
710	WUGUB	303-W	Front or Rear Mudguard Bolt Lockwasher01
711	WUGUC	H-6484	Front or Rear Mudguard Bolt, 5/16x2410

RIM, TANK, CHAINGUARD AND STAND—(Plate XIII)

712	WUGJO	K-7507	Front or Rear Rim (Specify Whether Gray or Cream Color) ..	1.75
713	WUGJU	K- 518	Gasoline Tank with Fittings for New Style Low Frame	22.00
	WUGKE	K- 535	Gasoline Tank for Old High Frame (4 gallons)	27.00
714	WUGKO	K- 595	Rear Stand for New Low Frame	3.00
	WUGKU	K- 594	Rear Stand for Old High Frame	3.00
715	WUGLI	K-5886	Rear Stand Hinge, Inside25
716	WUGLY	K-5888	Rear Stand Hinge, Outside25
717	WUGME	K-5882	Rear Stand Hinge Rivet01
718	WUGMO	K-5884	Rear Stand Hinge Bolt25
719	WOCMO	304-W	Rear Stand Hinge Bolt Lockwasher01
720	WUGNY	267-N	Rear Stand Hinge Bolt Nut05
721	WUGGE	K-2458	Rear Stand Latch25
722	WUGOC	2806	Rear Stand Latch Screw05
723	WODAL	302-W	Rear Stand Latch Screw Lockwasher01
724	WUGOG	1925	Rear Stand Latch Screw Nut05
725	WUGOL	K-5200	Gasoline Tank Transfer10
726	WUGOM	2766	Mudguard Transfer05
727	WUGOP	K-5199	Head Transfer02
728	WUGOS	K- 596	Chain Guard Assembly for New Low Frame	2.00
	WUGPO	K- 591	Chain Guard Assembly for Old High Frame	2.00
729	WUGRY	K-5897	Chain Guard Clip, Rear10
730	WUGSE	171-R	Chain Guard Clip Bolt, Rear15
731	WUGSO	3908	Chain Guard Clip Bolt Lockwasher01
732	WUGSD	K-5896	Chain Guard Clip, Front15
733	WUGTA	K-5845	Chain Guard Clip Bolt, Front15
734	WUGTI	2378	Chain Guard Clip Bolt Nut05

LOCK WASHERS

WUABU	303-W	Lockwasher, 1/4"01
WODAL	302-W	Lockwasher, 3/4"01
WOCMO	304-W	Lockwasher, 3/8"01
WODON	301-W	Lockwasher, 3/16"01
WOENO	306-W	Lockwasher, 1/2", Light03
WOOHO	300-W	Lockwasher, 5/32"01
WUERT	XK-3908	Lockwasher, 3/16"01
WUHEV	XK-1820	Lockwasher, 7/16"01
WUHIF	XK-1268	Lockwasher, 3/8"02
WUHIG	XK-2821	Lockwasher, 3/4"01
WDCOC	K-6710	Lockwasher, 1/2", Heavy05

SHIMS

WOCKU	K-1028	Crankshaft Front and Clutch Bearing Shim10
WOCNI	K-1029	Crankshaft Center Bearing Shim12
WOCOC	K-1034	Crankshaft Rear Bearing Shim10
WREOJ	K-1043	Countershaft Bearing Shim08
WOCFY	K-1930	Connecting Rod Shim07
WRAEW	K-1310	Crankshaft Thrust Bearing Shim05
WREAW	K-3304	Small Bevel Gear Shim02
WDHLL	K-2753	Thrust Shim for Clutch End, Heavy05
WUHIM	K-2734	Thrust Shim for Clutch End, Light05
WDHIP	H-6485	Gear Shifter Finger Shaft Shim02

KEYS

WRAOG	XK-2347	Clutch Release Lever Key No. 602
WODOD	408-Key	Crankshaft Key No. 802
		(Also used for Camshaft and Small Bevel Gear)	
WUCDE	K-6013	Fork Stem No. 1304
WRAOC	XK-2373	No. 3 Key used for Clutch Release Fork, Gear Shifter Finger, Main Driving Gear Reverse Idler Spacer, Reverse Driving Gear, Reverse Shifter Finger, Spline Shaft and Magneto Pulley02
WRAOG	XK-2347	Engine Sprocket Key No. 6, Old Style with Four Keyways02
WRAYU	K-3069	Engine Sprocket Key No. 9, Special for New Style One Keyway Sprocket02
WOBGH	K-1307	Special Offset Key for Crankshaft Gear02
WUAZY	XK-2671	Key for Generator Shaft03

SERVICE TOOLS—(Plate XIV)

Photo No.	Code	Parts No.	NAME	These Prices are Net
735-T	WUGUL		Clutch Bearing Reamer and Main Bearing Truing Bar	\$25.00
736-T	WUGUM		Main Bearing Reamer and Guides	60.00
737-T	WUGUP		Countershaft Bearing Reamer	30.00
738-T	WUGUS		Prying-off Wedge for Small Bevel Gear	1.00
739-T	WUHAC		Tappet Adjusting Wrench	.25
740-T	WUHAF		Tappet Adjusting Wrench	.20
741-T	WUHAG		Tappet Adjusting Wrench	.35
742-T	WUHAL		5/16" and 3/8" Nut Wrench	.30
743-T	WUHAM		Shifter Lever Nut Wrench	.40
744-T	WUHAS		Cylinder Stud Nut Wrench	1.00
745-T	WUHAW		Timing Gear Stud Nut Wrench	.55
746-T	WUHED		Socket Wrench	.50
747-T	WUHEH		Socket Wrench	.55
748-T	WUHEJ		Socket Wrench	.45
749-T	WUHEK		Gear Shifter Shaft Cap Nut Wrench	.40
750-T	WUHEN		Valve Seat Cutter	2.50
751-T	WUHER		Main Bearing Stud Nut Wrench	1.00
752-T	WUHET		Special 3/8" x 14 Thread Tap for Tapping Frame Rear Stay Crowns for New Larger Center Sidecar Attachment Adjusting Screw	1.00

HENDERSON AND SUPER X SIDECAR PARTS

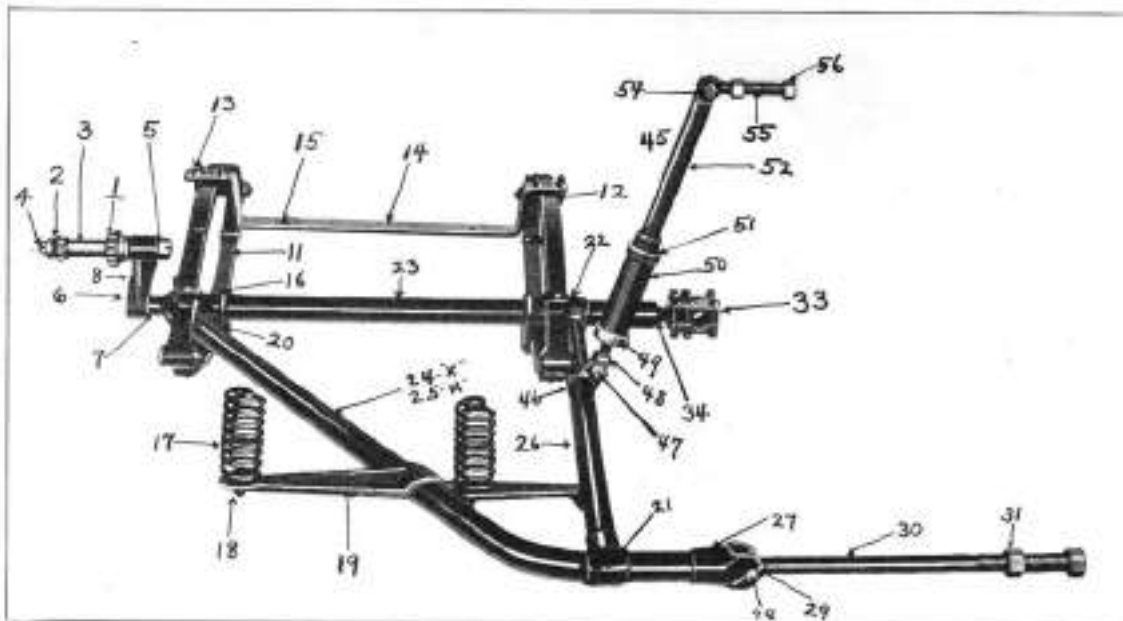

Photo No.	Code	Part	No. Reqd.	NAME	Price
	YABAF	HX-7296	1	Henderson Sidecar Wheel, R. H., less Tire	\$18.50
	YABAG	HX-7308	1	Henderson Sidecar Wheel, L. H., less Tire	18.50
	YAHAL	P4-9613	1	Super X Sidecar Wheel, R. H., less Tire	18.25
	YAHAM	P4-9614	1	Super X Sidecar Wheel, L. H., less Tire	18.25
	YAHAP	HX-7279	1	Hub Assembly with Spindle and Bearings	16.15
	YABAS	HX-7286	1	Sidecar Wheel Hub Only	5.25
	YAHAW	HX-7288	1	Hub Cap	.75
	YABBE	HX-7244	1	Roller Bearing Dust Cap	.20
1	YABCE	HX-7245	1	Roller Bearing Cone, Inner (with rollers)	1.60
2	YABCO	HX-7245	1	Roller Bearing Cone, Outer (with rollers)	1.45
	YAHDA	HX-7263	1	Roller Bearing Cup, Large	.55
	YABED	HX-7264	1	Roller Bearing Cup, Small	.40
	YABEH	HX-7284	1	Roller Bearing Cone, Outer (left hand chassis only) (with rollers)	1.45
	YABEK	K-7507	1	Henderson Sidecar Rim	1.75
	YABER	P4-9082	1	Super X Sidecar Rim	1.50
	YABET	K-7510	40	Henderson Spokes	.04
	YABEX	P4-9084	40	Super X Spokes (8 1/2" long)	.04
	YABFO	K-7509	40	Nipples for Henderson or Super Spokes	.02
3	YABHA	HX-7225	1	Stub Axle for Left Hand Chassis	5.35
	YABIB	HX-7225	1	Stub Axle for Right Hand Chassis	5.35
4	YABIF	HX-7242	1	Axle Nut, Outside, Right Hand Chassis	.15
	YABIL	HX-7249	1	Axle Nut, Outside, Left Hand Chassis	.15
	YABIP	HX-7241	1	Axle Nut Washer	.04
5	YABIS	HX-3211	1	Stub Axle Nut, 1/2"-16	.20
	YABKA	3059	1	Axle Nut Cotter Pin	.01
6	YABLE	HX-7273	1	Axle Extension Assembly, Complete	5.75
7	YABLO	HX-7225	1	Axle Extension Tube, Only (Price on Application)	
8	YABMA	HX-7201	1	Stub Axle Support, Only (Price on Application)	
	YABNU	HX-7251	1	Extension Axle Reinforcement, Only (Price on Application)	
9	YABOK	HX-7282	1	Main Axle Clamping Bolt, 1/2" x 2 1/2"	.30
10	YABON	HX-7283	1	Main Axle Clamping Bolt Nut, 1/2"-13	.05

HENDERSON AND SUPER X SIDECAR PARTS

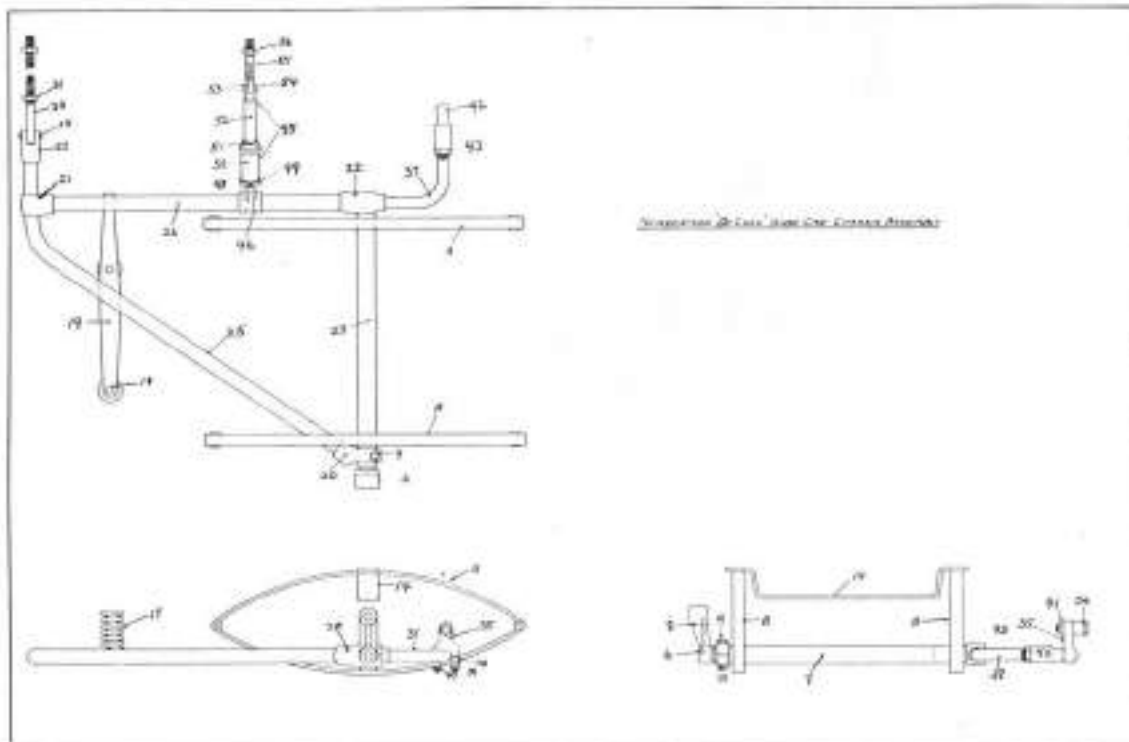

Photo No.	Code	Parts No.	NAME	Price
	YABOT	3059	1 Main Axle Clamping Bolt, Nut, Cotter Pin	\$.01
	YABPA	HX-7211	2 Spring Saddles	.15
11	YABPY	HX-7216	2 Rear Main Springs	6.95
12	YABRI	HX-7215	4 Body Support "U" Bolts	.10
13	YABSA	204	8 Body Support "U" Bolts, Nuts	.04
14	YABTO	HX-7214	1 Body Support Rear	1.00
15	YABUD	HX-7267	2 Body Support Bolts	.05
16	YABUK	HX-7212	4 Axle "U" Bolts	.15
	YABUT	HX-7213	4 Axle "U" Bolts, Clamps	.10
	YABUX	207	8 Axle "U" Bolts, Clamps, Nuts	.05
	YACAF	3908	8 Body Support "U" Bolt Nut Lockwashers	.01
17	YACAL	HX-3228	2 Front Body Springs	1.00
18	YACAM	HX-7267	2 Front Body Springs, Bolts	.05
19	YACAP	HX-7217	1 Front Spring Support (Price on Application)	
	YACAS	HX-7302	1 Sidecar Chassis Complete for Henderson, Right Hand Only (Price on Application)	
	YACAW	HX-7304	1 Sidecar Chassis Complete for Henderson, Left Hand Only (Price on Application)	
	YACBO	P4-9608	1 Sidecar Chassis Complete for Super X, Right Hand Only (Price on Application)	
	YACDA	P4-9612	1 Sidecar Chassis Complete for Super X, Left Hand Only (Price on Application)	
20	YACDI	KX-7202	1 Axle to Diagonal Tube connecting Fitting (Price on Application)	
21	YACED	HX-7209	1 Front Tee Fitting (Price on Application)	
22	YACEH	P4-9384	1 Rear Tee Fitting (Price on Application)	
23	YACEN	P4-9396	1 Main Axle Tube (Price on Application)	
24	YACER	P4-9395	1 Diagonal Tube, for Super X Only (Price on Application)	
25	YACET	HX-7228	1 Diagonal Tube, for Henderson Only (Price on Application)	
26	YACEX	HX-7227	1 Parallel to Frame Tube (Price on Application)	
27	YACFE	HX-7205	1 Henderson Chassis Front Connection Clevis (Price on Application)	
28	YACFO	HX-7218	1 Henderson Chassis Front Connection Clevis Pin	.15
29	YACHA	K-6270	2 Henderson Chassis Front Connection Clevis Cotter Pin	.01
30	YACIB	HX-7219	1 Henderson Front Clevis Bolt	1.75
31	YACIF	HX-7246	2 Henderson Front Clevis Bolt, Nut	.10
			(Note that Front of Chassis and Connections for Super X are Different from those for Henderson and are as follows:	
	YACIL	P4-9380	1 Front Sidecar to Frame Clamp for Super X Only	2.65
32	YACIP	P4-9391	1 Front Ball Connection for Super X Only	1.55
	YACIS	P4-9392	2 Ball Joint Cap Bolts, Front, for Super X Only	.25
	YACKA	P4-9393	4 Ball Joint Cap Bolts, Nuts, for Super X Only	.05
	YACLE	P4-9394	4 Sidecar to Frame Clamp "U" Bolts, Front, for Super X Only	.15
	YACLO	P4-9383	2 Ball Joint Caps for Front and Rear Connections, for Super X Only	1.30
	YACMO	207N	12 Nuts for Front and Rear Frame Clamp "U" Bolts	.05
	YACOD	1268	12 Lockwashers for Frame Clamp "U" Bolts	.01
33	YACOH	HX-7277	1 Rear Sidecar Connection Complete as shown for Old Style Henderson Chassis Only	5.75
34	YACOL	HX-7220	1 Ball Frame Tube Fitting for Rear Connection (Price on Application)	
	YACON	HX-7207	1 Ball Cap Rear Connection for Henderson Chassis, as shown	.50
	YACOR	HX-7205	1 Henderson Rear Connection Lower Half, as shown	1.20
	YACOT	HX-7206	1 Henderson Rear Connection Upper Half, as shown	.85
	YACOX	K-1082	4 Bolts for Henderson Rear Connection, as shown	.25
	YACRA	207	4 Nuts for Same	.05
	YACSE	HX-7293	2 Rear Ball Connection Bolt	.25
	YACTA	208	2 Rear Ball Connection Bolt, Nut	.05
	YACTO	2607	2 Rear Ball Connection Bolt, Nut, Cotter Pin	.01

HENDERSON AND SUPER X SIDECAR PARTS

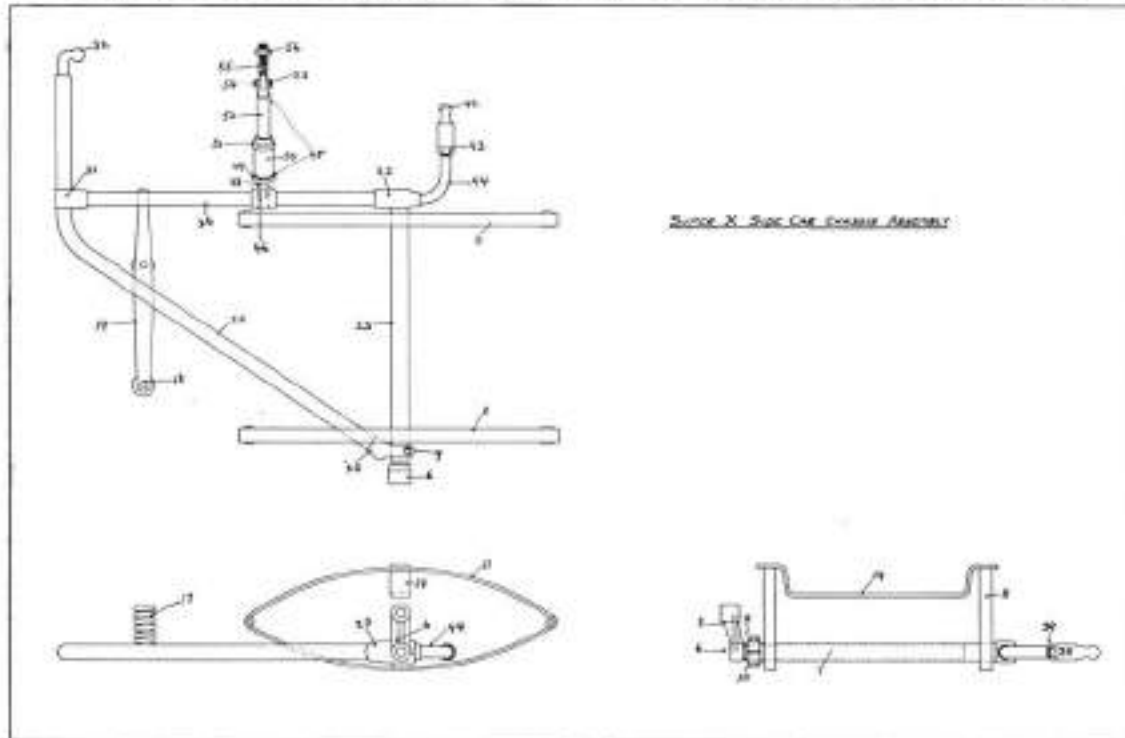

Photo No.	Code	Parts No.	NAME	Price
			New Style Rear Connection Fittings for Henderson	
35	YACUD	HX-7287	Rear Frame Connection	\$ 2.40
36	YACUN	HX-7288	Rear Frame Connection Bolt	.75
37	YACUR	HX-7289	Chassis Connection Rear	1.00
38	YACUX	P4-9381	Ball Joint Cap	1.30
39	YADAK	P4-9394	Ball Joint Cap Studs	.15
40	YADAN	P4-9391	Ball Joint Cap Studs, Nuts	.05
	YADAR	1601	Ball Joint Cap Studs, Cotter Pins	.01
41	YADAX	3211	Rear Frame Connection Bolt Nut	.20
42	YADDA	P4-9387	Rear Ball Connection	1.80
43	YADEC	P4-9386	Rear Connection Locknut	.50
	YADEL	P4-9381	Rear Connection Fittings for Super X	
	YADES	P4-9382	Sidecar to Frame Clamp, Rear (R. H.)	2.40
44	YADFY	P4-9385	Sidecar to Frame Clamp, Rear (L. H.)	2.40
45	YADEC	P4-9386	Chassis Connection Rear	.85
42	YADDA	P4-9387	Chassis Rear Connection Locknut	.30
	YADHU	P4-9388	Rear Ball Connection	1.80
	YADID	P4-9389	Sidecar to Frame Clamp "U" Bolt Rear Top	.15
	YADIN	P4-9390	Sidecar to Frame Clamp "U" Bolt Rear Bottom	.15
	YADIR	K-1603	Ball Joint Cap Studs, Rear	.15
			Cotter Pins	.01
45	YADIX	HX-7276	Stabilizer Center Connection Fittings for Henderson and Super X	
46	YADKA	HX-7247	Stabilizer Assembly Complete	7.50
47	YADLE	A-2040	Stabilizer Connection to Chassis	1.45
	YADMO	A-2041	Stabilizer Lower Clevis Bolt	.55
48	YADNA	HX-7260	Stabilizer Lower Clevis Bolt, Nut	.15
49	YADOB	G-2008	Stabilizer Lower Clevis	1.80
50	YADOL	A-2050	Stabilizer Tube Cap	2.50
51	YADOS	HX-7259	Stabilizer Lower Tube	1.50
52	YADPA	HX-7257	Stabilizer Cup	.85
	YADRU	HX-7262	Stabilizer Upper Clevis	.70
	YADSE	G- 228	Stabilizer Springs	1.00
	YADTA	G-2035	Stabilizer Spring Nut	.15
53	YADUB	210	Stabilizer Spring Washer	.15
54	YADUK	HX-7221	Stabilizer Upper Tube Clevis Bolt Nut	.05
55	YADUM	HX-7254	Stabilizer Upper Tube Clevis Bolt	.10
			Center Connection Upper Adjusting Screw	1.10
			<small>Screw Diameter has been increased from 3/8" to 7/8", necessitating threading hole in Henderson Frame Fitting (Photo No. 671) for 7/8" x 11 thread for which Special Tap can be supplied at \$1.00 net.</small>	
56	YAEBO	HX-7246	Center Connection Upper Adjusting Screw, Nut	.30
	YAECH	HX-7206	Stabilizer Clamp "U" Bolt	.10
	YAECT	K-6629	Stabilizer Spring Nut Locknut	.05
			In ordering Sidecar Bodies and Mudguards specify whether Henderson Blue or Super X Green.	
	YAEBA	HX-7235	Sidecar Body, Right Hand Chassis (Price on Application)	
	YAEBS	HX-7256	Sidecar Body, Left Hand Chassis (Price on Application)	
	YAEFT	HX-7285	Delivery Van Body (Price on Application)	
	YAEGO	HX-7229	Sidecar Mudguard	6.95
	YAEHA	HX-7235	Sidecar Mudguard, Spacer Front	.45
	YAEHT	HX-7236	Sidecar Mudguard, Bolt, Front and Center	.10
	YAEKO	HX-7238	Sidecar Mudguard, Center Spacer	.45
	YAEKU	HX-7239	Sidecar Mudguard, Spacer Bolt, Rear	.10
	YAELO	HX-7248	Sidecar Mudguard, Spacer, Rear	.45
	YAEKX	207	Sidecar Mudguard, Bolt Nuts	.05
	YAEKX	1268	Sidecar Mudguard, Lockwashers	.01