**INDICE**

Testa cilindro	Pag. 2/5
Cilindro	Pag. 4/5
Valvola di scarico	Pag. 4/5
Pistone	Pag. 8/5
Fasce elastiche	Pag.10/5
Spinotto pistone e cuscinetto di biella	Pag.12/5
Albero motore	Pag.12/5
Lamelle aspirazione e raccordo corpo	Pag.14/5
Frizione	Pag.16/5
Pompa olio	Pag.20/5
Ingranaggi primari	Pag.20/5
Trasmissione	Pag.20/5
Ruota libera	Pag.24/5
Cuscinetti e paraoli	Pag.24/5
Seeger e anelli elastici	Pag.24/5

INDEX

Cylinder head	Pag. 3/5
Cylinder	Pag. 5/5
Exhaust valve	Pag. 5/5
Piston	Pag. 9/5
Piston ring	Pag.11/5
Piston pin and connecting rod bearing	Pag.13/5
Crankshaft	Pag.13/5
Reed valve and housing joint	Pag.15/5
Clutch	Pag.17/5
Oil pump	Pag.21/5
Primary gear	Pag.21/5
Transmission	Pag.21/5
Free wheel	Pag.25/5
Bearing and oil seal	Pag.25/5
Circlip and washer	Pag.25/5

VERZEICHNIS

Zylinderkopf	Abb. 3/5
Zylinder	Abb. 5/5
Auslass-Ventil	Abb. 5/5
Kolben	Abb. 9/5
Kolbenringe	Abb.11/5
Kolbenbolzen und Pleuelnngenlager	Abb.13/5
Kurbervelle	Abb.13/5
Zugeventil und Korper-Verbindung	Abb.15/5
Kupplung	Abb.17/5
Ölpumpe	Abb.21/5
Primäzhahäder	Abb.21/5
Getriebe	Abb.21/5
Freilauf	Abb.25/5
Lager und Dichtringen	Abb.25/5
Sprengringe und Scheibe	Abb.25/5

Modello 500 V2

MANUALE D'OFFICINA

© 1997 by BIMOTA S.p.A.

1ª Edizione - 10/1997

Tutti i diritti riservati. Ogni pubblicazione o utilizzo senza permesso scritto da parte della BIMOTA S.p.A. è severamente vietata/o.

Verificato: A.Q.

Realizzato: Tecnema s.r.l.

Model 500 V2

SERVICE MANUAL

© 1997 by BIMOTA S.p.A.

1st Edition - 10/ 1997

All right reserved. Any reprinting or unauthorized use without the written permission of BIMOTA S.p.A. is expressly prohibited.

Verified: A.Q.

Realisation: Tecnema s.r.l.

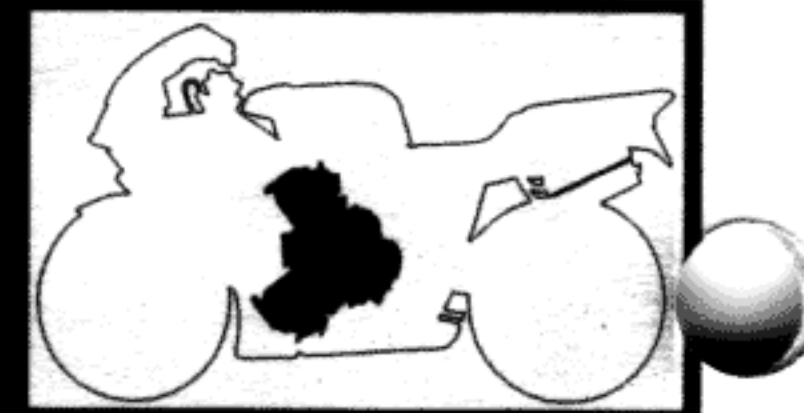
**TESTA CILINDRO**

1. Eliminare:
depositi di carbonio.
Usare un raschietto con punta arrotondata

NOTE:

Non utilizzare degli strumenti appuntiti onde evitare di danneggiare o di raschiare:
filetto della candela di accensione
testa cilindro

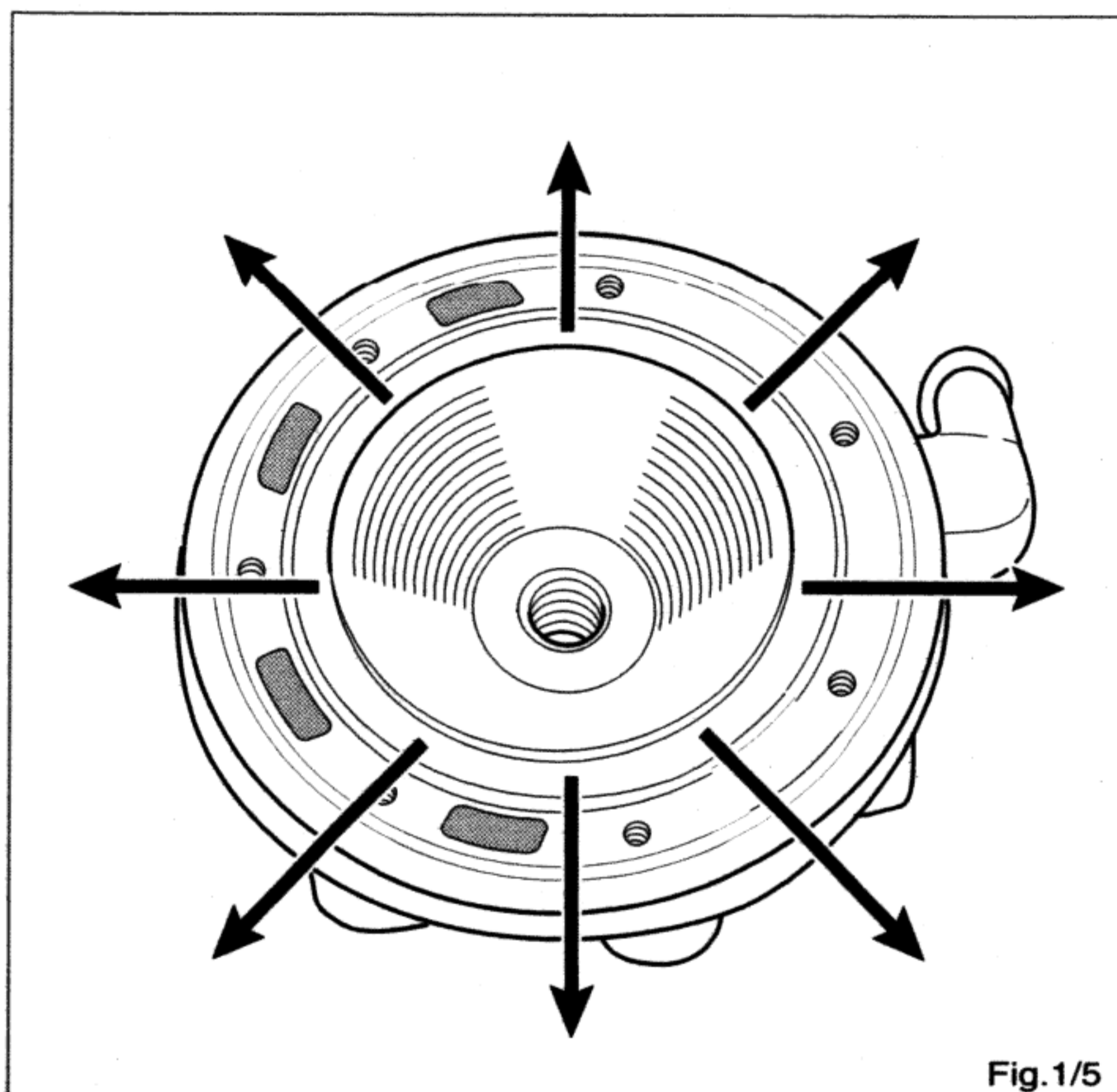
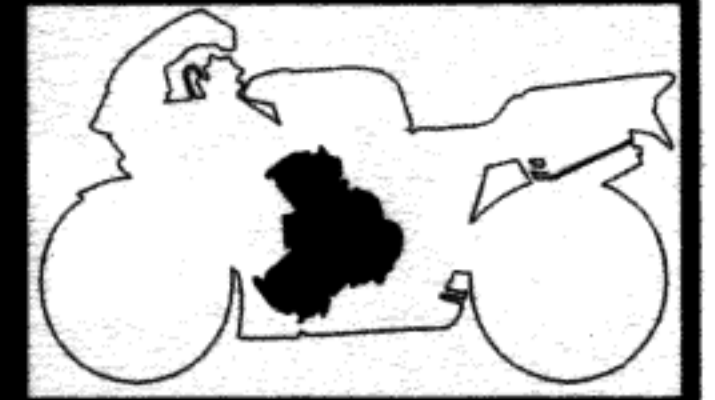

Fig.1/5

2. Misurare:
deformazione della testa cilindro
fuori dalle specifiche ⇒ sostituire



**Limite di deformazione della testa cilindro:
fino a 0,05 mm. (0,002 in)**



CYLINDER HEAD

1. Eliminate:
carbon deposit.
Use rounded scraper

NOTE:

Do not use a sharp instrument and avoid damaging or scratching:

- Spark plug threads
- Cylinder head

ZYLINDERKOPF

1. Entfernen:
Ölkohleablagerungen.
Einen abgerundeten Schaber verwenden.

HINWEIS:

Niemals scharfkantige Werkzeuge verwenden, um Kratzer und Beschädigungen zu vermeiden.

- Gewinde der Zündkerzen
- Zylinderkopf

2. Measure:

Cylinder head warpage
Out of specification ⇒ Replace.

2. Messen:

Verzug des Zylinderkopfes
Abweichung von Spezifikation ⇒ erneuern.



**Cylinder Head Warp Limit:
Less than 0.05 mm (0.002 in)**



**Max. Zul. Verzug des Zylinderkopfes:
Weniger als 0,05 mm (0,002 in)**

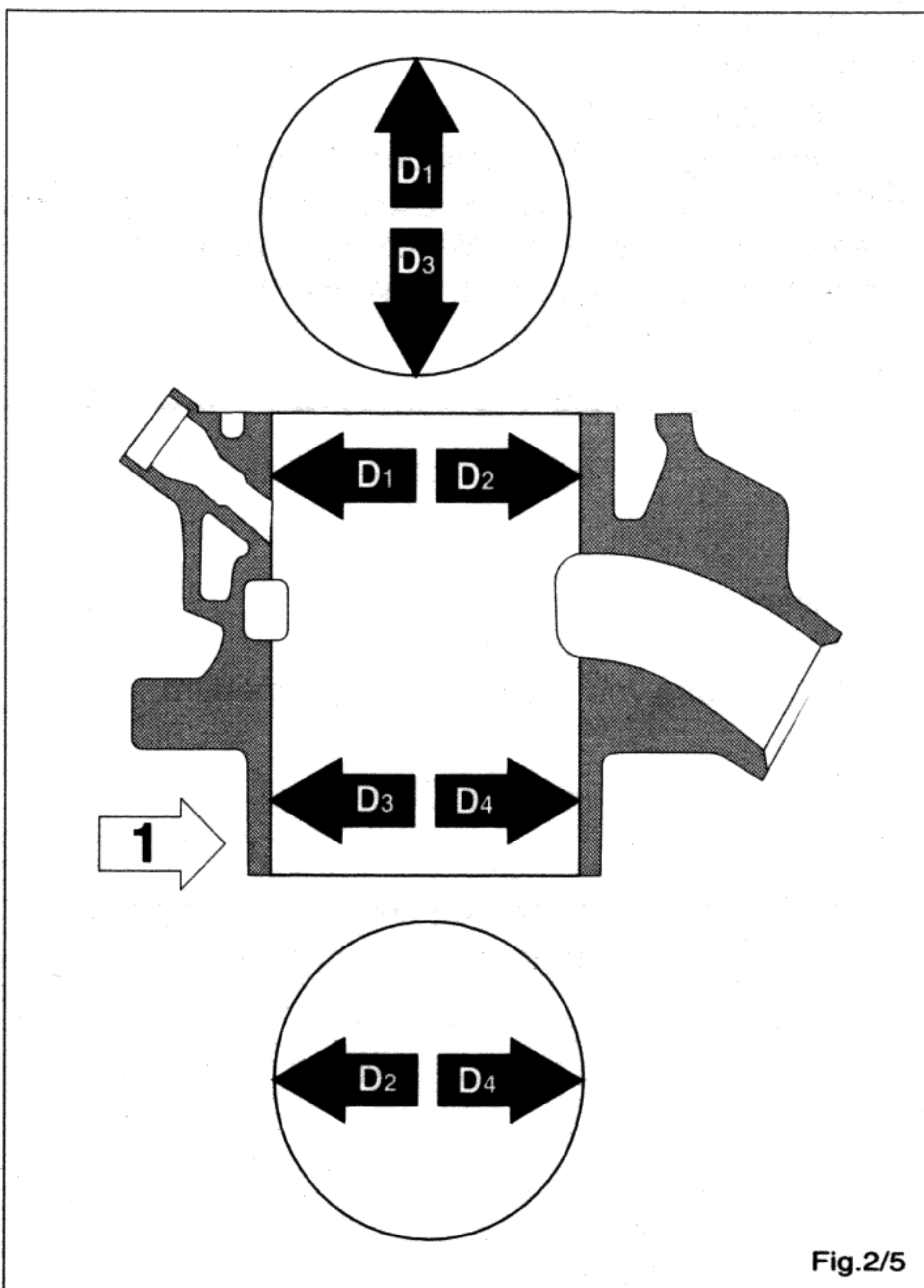
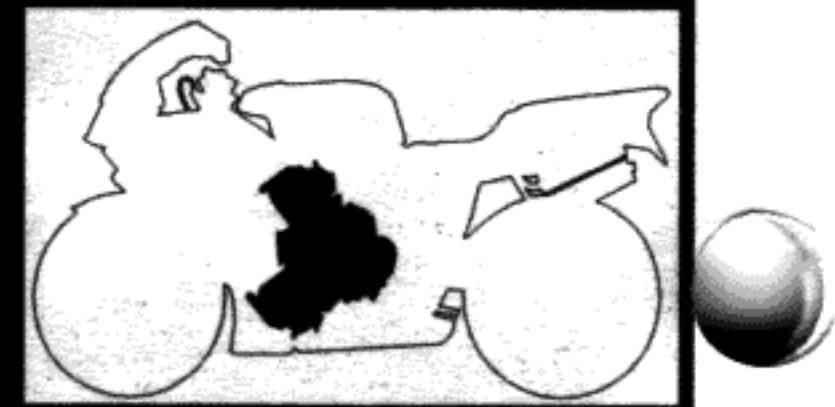



Fig.2/5

CILINDRO

1. Ispezionare:
pareti del cilindro
Usura o rigature ⇒ ripristinare
⇒ sostituire
2. Misurare:
Alesaggio del cilindro "D"
fuori dalle specifiche ⇒ ripristinare

NOTA:

La lettera "1" relativa all'individuazione del tipo di cilindro è stampigliata sul cilindro (vedi figura 2/5).

 Cilindro	Tipo "A"	Tipo "B"
Alesaggio del cilindro (Ø max.)	71,990~ 72,0 mm (2,8364 ~ 2,8368 in)	72,0~ 72,01 mm (2,8368 ~ 2,8371 in)
Conicità del cilindro Ø max. D1-D2 Ø min. D3-D4	0,0085 mm (0,00033 in)	0,0085 mm (0,00033 in)

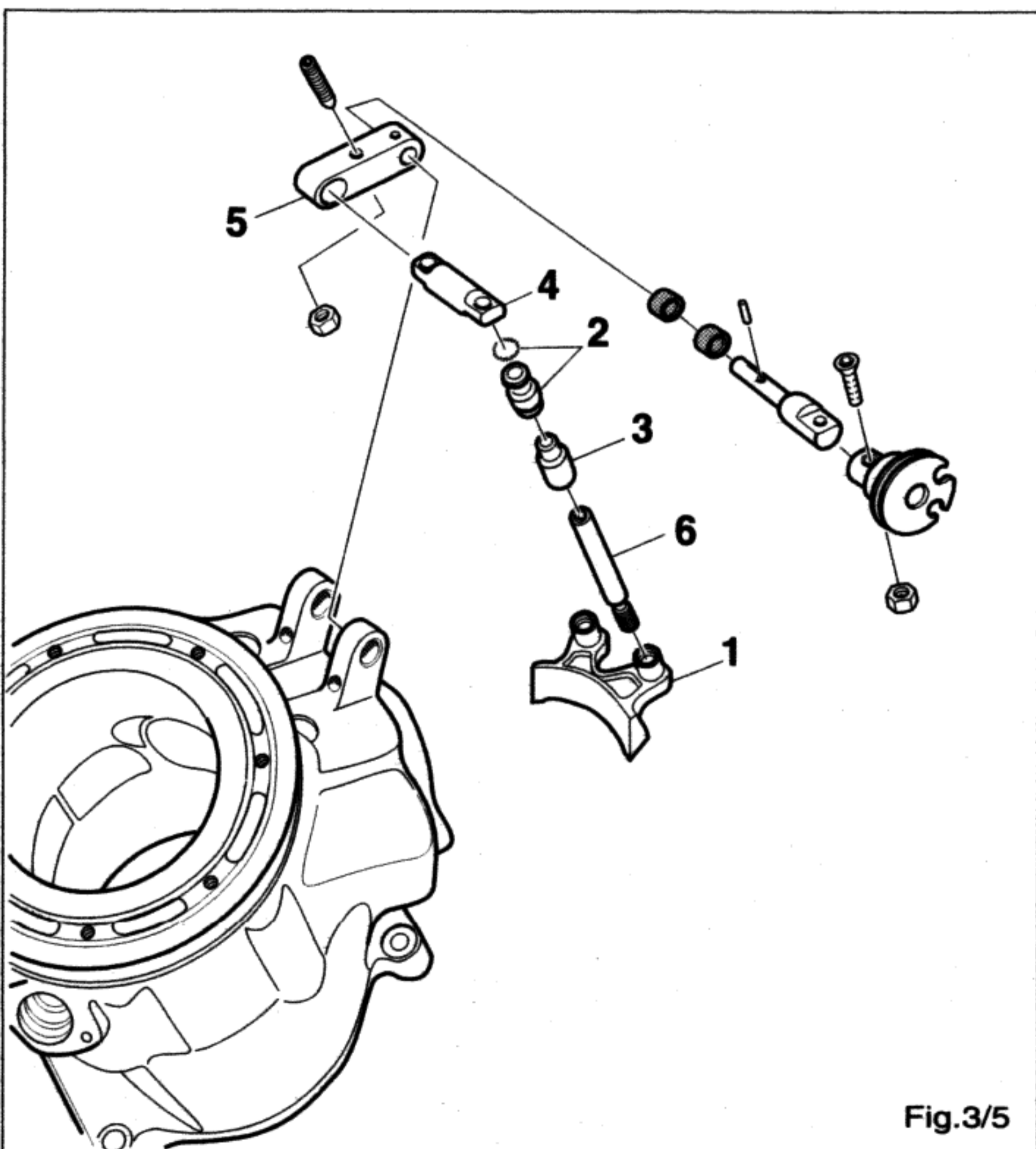
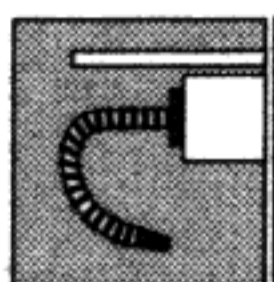

Fig.3/5

VALVOLA DI SCARICO

1. Esaminare:
valvola di scarico "1"
usura o rigature ⇒ sostituire
paraolio "2" (Qt. 2)
usura o danneggiamento ⇒ sostituire
boccole "3" (Qt. 2)
usura o danneggiamento ⇒ sostituire
2. Assemblaggio:
Ingrassare il bilanciere "4" e la biella "5", le boccole "3" e i paraoli "2".



Grasso al bisolfuro di molibdeno

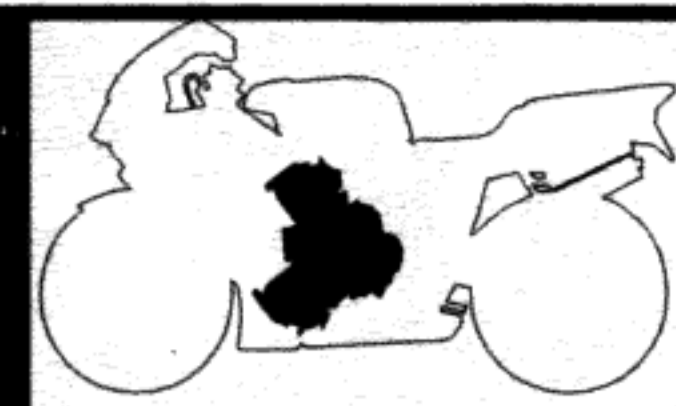

CYLINDER

- Inspect:
 - cylinder wall
 - Wear or scratches ⇒ Rebore
 - ⇒ Replace
- Measure:
 - cylinder bore "D"
 - Out of specification ⇒ Rebore.

NOTE:

The marks "1" for identifying the type of the cylinder is printed on the cylinder (Fig. 2/5).

	Cylinder Type "A"	Type "B"
Cylinder bore (Ø max)	71,990~ 72,0 mm (2,8364 ~ 2,8368 in)	72,0~ 72,01 mm (2,8368 ~ 2,8371 in)
Cylinder taper Ø max. D1-D2 Ø min. D3-D4	0,0085 mm (0,00033 in)	0,0085 mm (0,00033 in)

ZYLINDER

- Prüfen:
 - zylinderbohrungen
 - Abnutzung oder Kratzer ⇒ Aufbohren
 - ⇒ Erneuern.
- Messen:
 - zylinderbohrungsdurchmesser "D"
 - Abweichung von Spezifikation ⇒ Aufbohren.

HINWEIS:

Die Bez."1" für die Kennzeichnung des Zylindertyp ist rechts an der Zylinder (Abb. 2/5).

	Zylinder Typ "A"	Typ "B"
Zylinderbohrung (Ø max.)	71,990~ 72,0 mm (2,8364 ~ 2,8368 in)	72,0~ 72,01 mm (2,8368 ~ 2,8371 in)
Zylinderkonizität Ø max. D1-D2 Ø min. D3-D4	0,0085 mm (0,00033 in)	0,0085 mm (0,00033 in)

EXHAUST VALVE

- Inspect:
 - exhaust valve "1"
 - Wear or scratches ⇒ Replace.
 - oil seal "2" (Qt. 2)
 - Wear or damage ⇒ Replace.
 - bushing "3" (Qt. 2)
 - Wear or damage ⇒ Replace.
- Assembly:
 - grease the rocker arm "4", the connecting rod "5", the bushing "3" and oil seal "2".

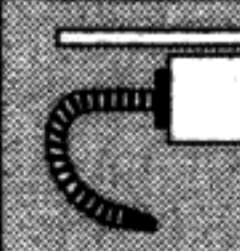
	Molydenum Disulfide Grease
---	----------------------------

AUSLASS-VENTIL

- Prüfen:
 - auslass-ventil "1"
 - Abnutzung oder Kratzer ⇒ Erneuern.
 - dichtring "2" (Zahl 2)
 - Abnutzung oder Beschädigung ⇒ Erneuern.
 - buchse "3" (Zahl 2)
 - Abnutzung oder Beschädigung ⇒ Erneuern.
- Montage:
 - skippebel "4", pleuelstange "5", buchse "3" und dichtringe "3" fetten.

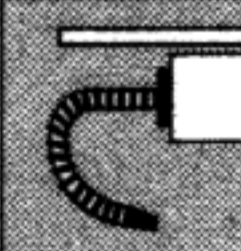
	Molybodän-Disulfid-Fett
---	-------------------------

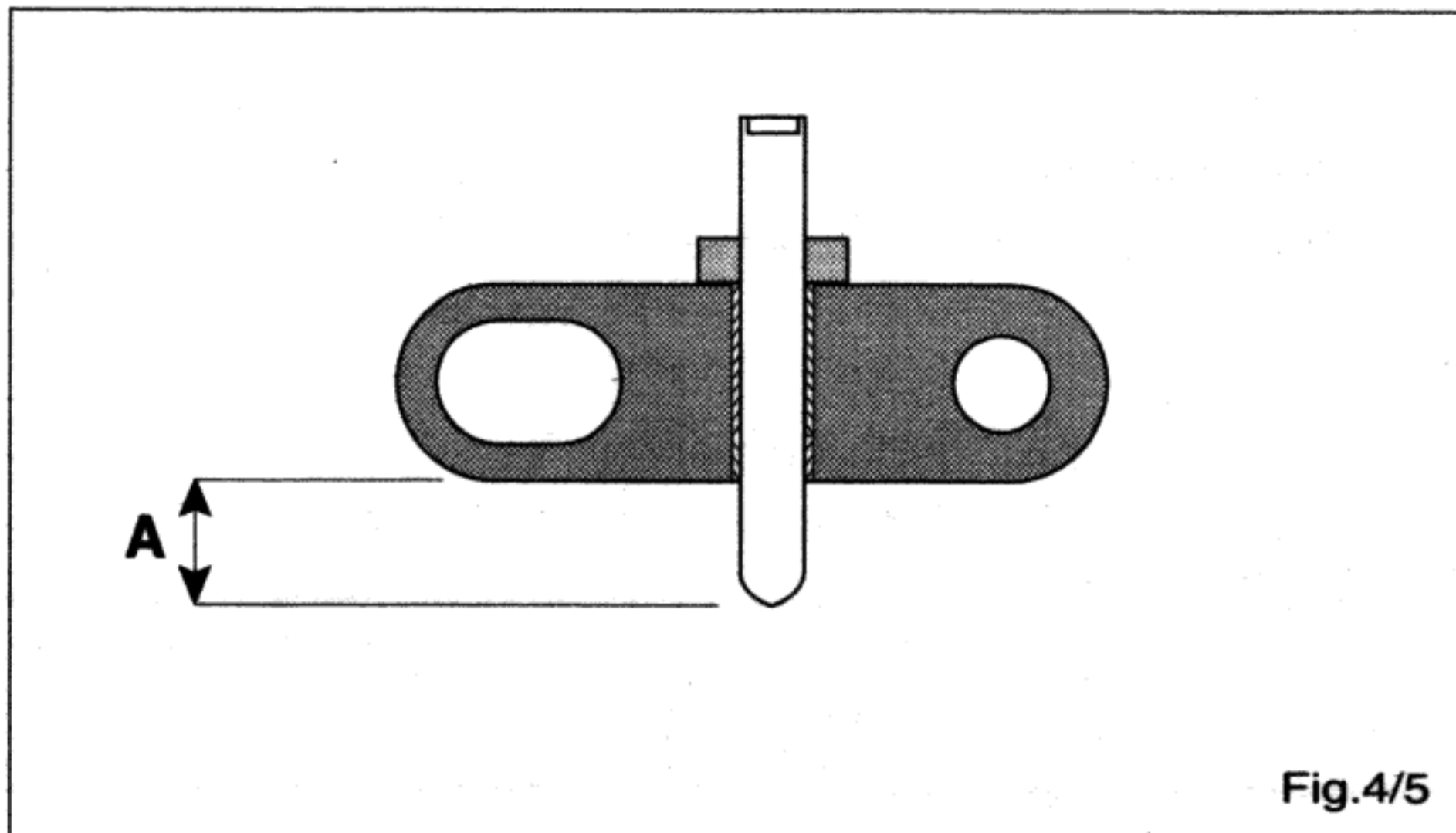
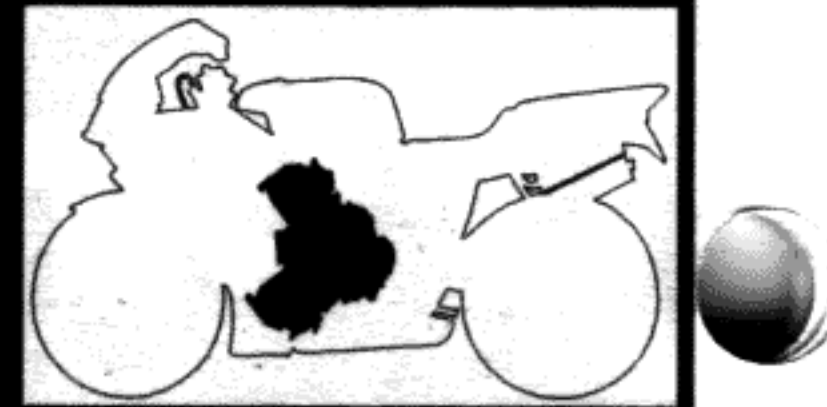

Fig.4/5

3. Verificare:
corsa della vite di fermo "A"



Distanza "A":
7.5 mm (0,30 in)

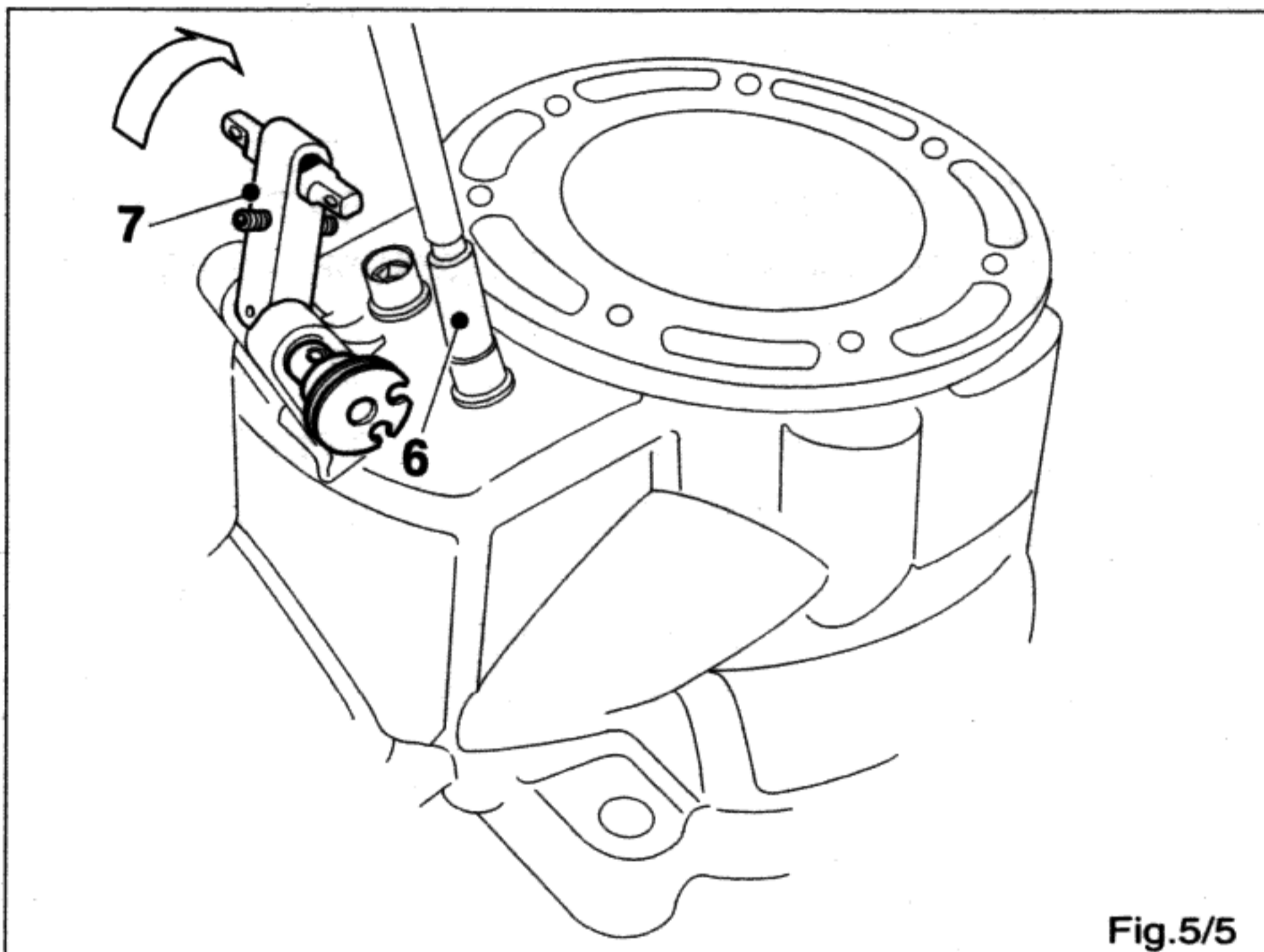
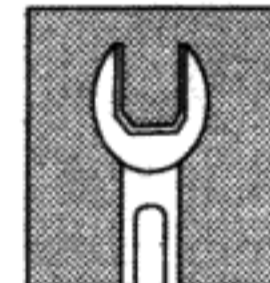

Fig.5/5

4. Eliminare dai perni:
depositi di carbonio
Usare spazzola o mola
5. Installare:
valvola di scarico
6. Serrare:
perni "6" (Qt.2)



Perni valvola di scarico:
10 Nm (1,0 m · kg, - 7,23 ft · lb)

7. Ruotare:
biella "7"

8. Serrare:
viti "8" (Qt. 2)



Frenafilietti Loctite 542

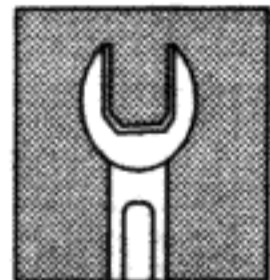

Viti valvola di scarico:
7 Nm (0,7 m · kg - 5,63 ft · lb)

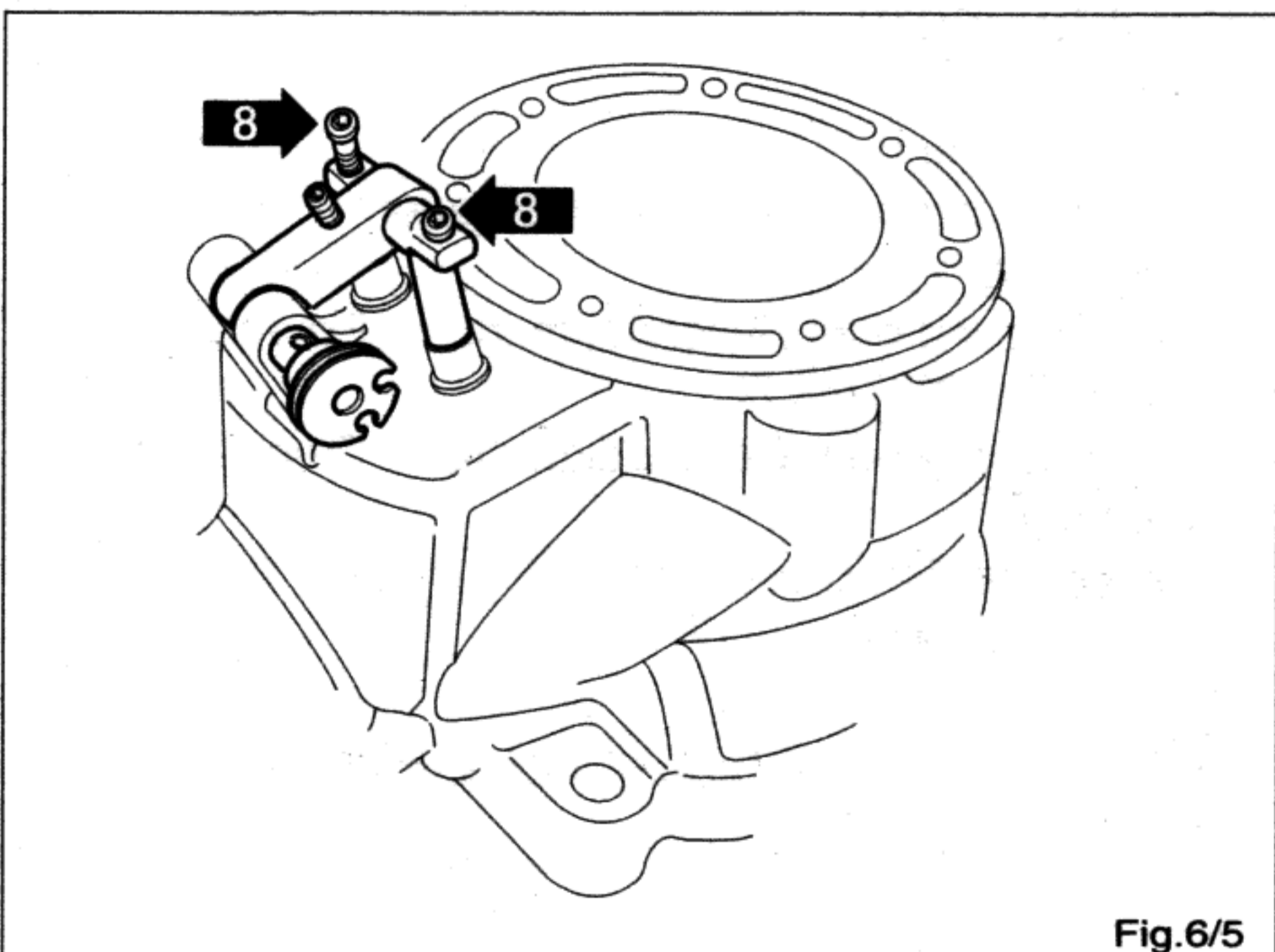
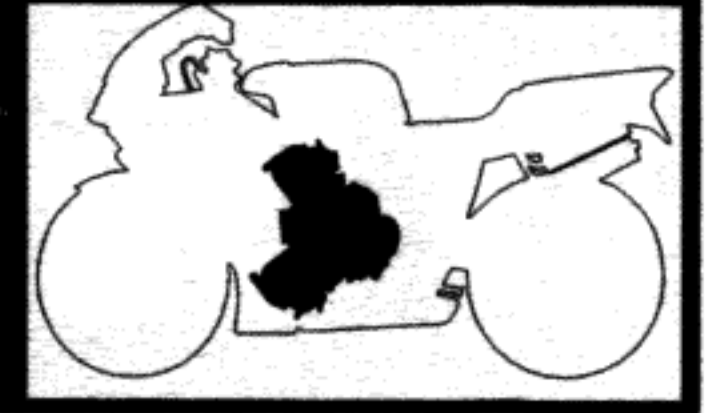

Fig.6/5



3. Inspection:
stop-screw gap "A"



Gap "A":
7.5 mm (0,30 in)

3. Inspektion:
Drosselanschlag Schraube "A"



Spalt "A":
7.5 mm (0,30 in)

4. Eliminate (pins):
carbon deposit.
Use metallic brush or grinding wheel
5. Install:
exhaust valve
6. Tighten:
pin "6" (Qt.2)

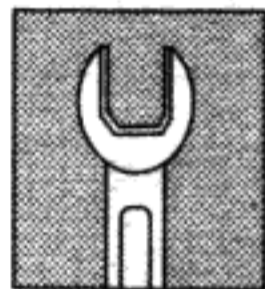

Exhaust valve pins:
10 Nm (1,0 m · kg, - 7,23 ft · lb)

4. Entfernen (Bolzen):
Ölkohleablagerungen.
Drahtbürste oder Schmirgelscheibe verwenden.
5. Einbauen:
Auslass-ventil
6. Festziehen:
paßstifte "6" (Zahl 2)

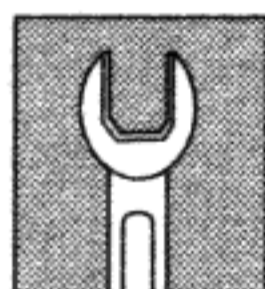

Paßstifte der Auslass-ventil :
10 Nm (1,0 m · kg, - 7,23 ft · lb)

7. Turn:
connecting rod "7"

7. Drehen:
dichtringe "7"

8. Tighten:
screw "8" (Qt. 2)

8. Festziehen:
schraube "8" (Zahl 2)



Locking agent - Loctite 542



Sicherungslack - Loctite 542



Exhaust valve screws:
7 Nm (0,7 m · kg - 5,63 ft · lb)

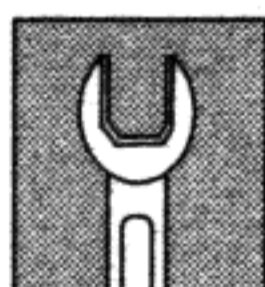

Schraube der Auslass-ventil :
7 Nm (0,7 m · kg - 5,63 ft · lb)

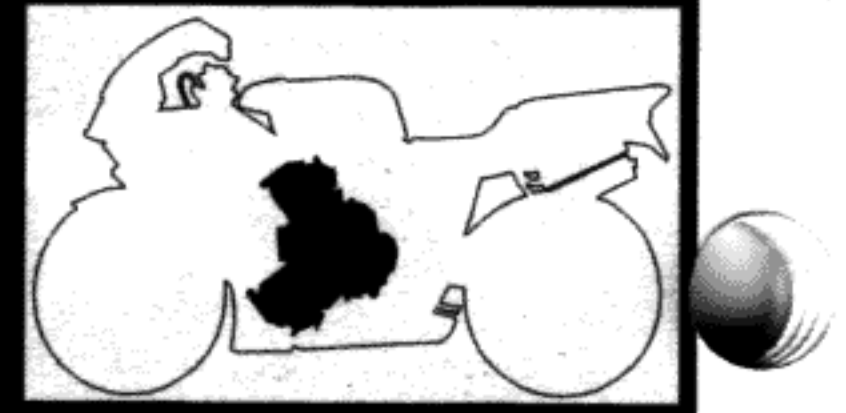

PISTONE

1. Esaminare:
pareti del pistone
Usura, rigature o danneggiamento ⇒ Sostituire
2. Misurare:
diametro esterno "P" del pistone (usare micrometro)
Fuori dalle specifiche ⇒ Sostituire

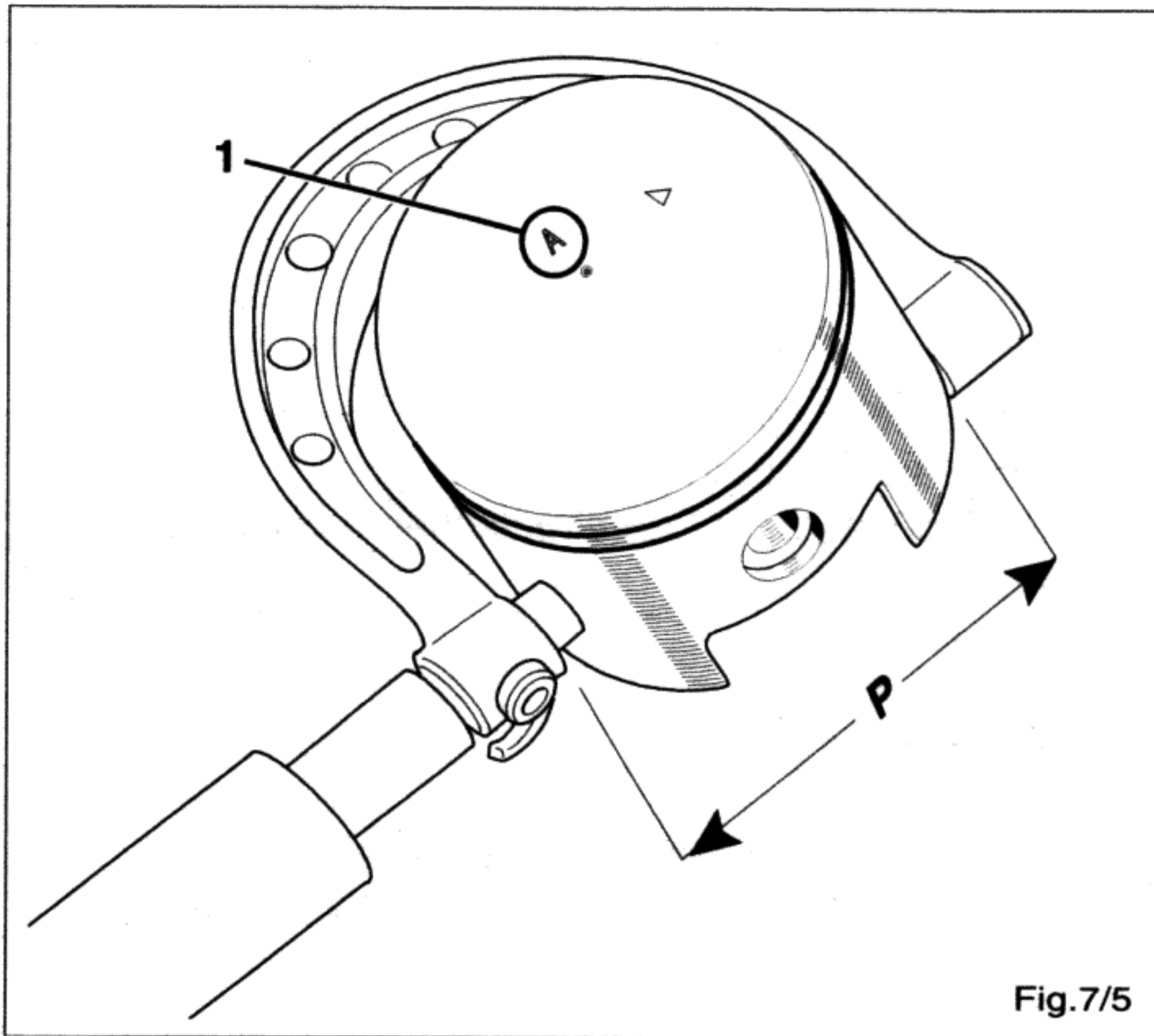

Fig.7/5

NOTA:

La misura va effettuata ad una altezza di 15 mm. (0,6 in) dal bordo inferiore del pistone.

NOTA:

La lettera "1" relativa all'individuazione del tipo di pistone è stampigliata sul pistone (vedi figura 7/5).

Tipo pistone	Diametro esterno "P"
"A"	71,955 ~ 71,965 mm (2,8350 ~ 2,8354 in)
"B"	71,965 ~ 71,975 mm (2,8354 ~ 2,8358 in)

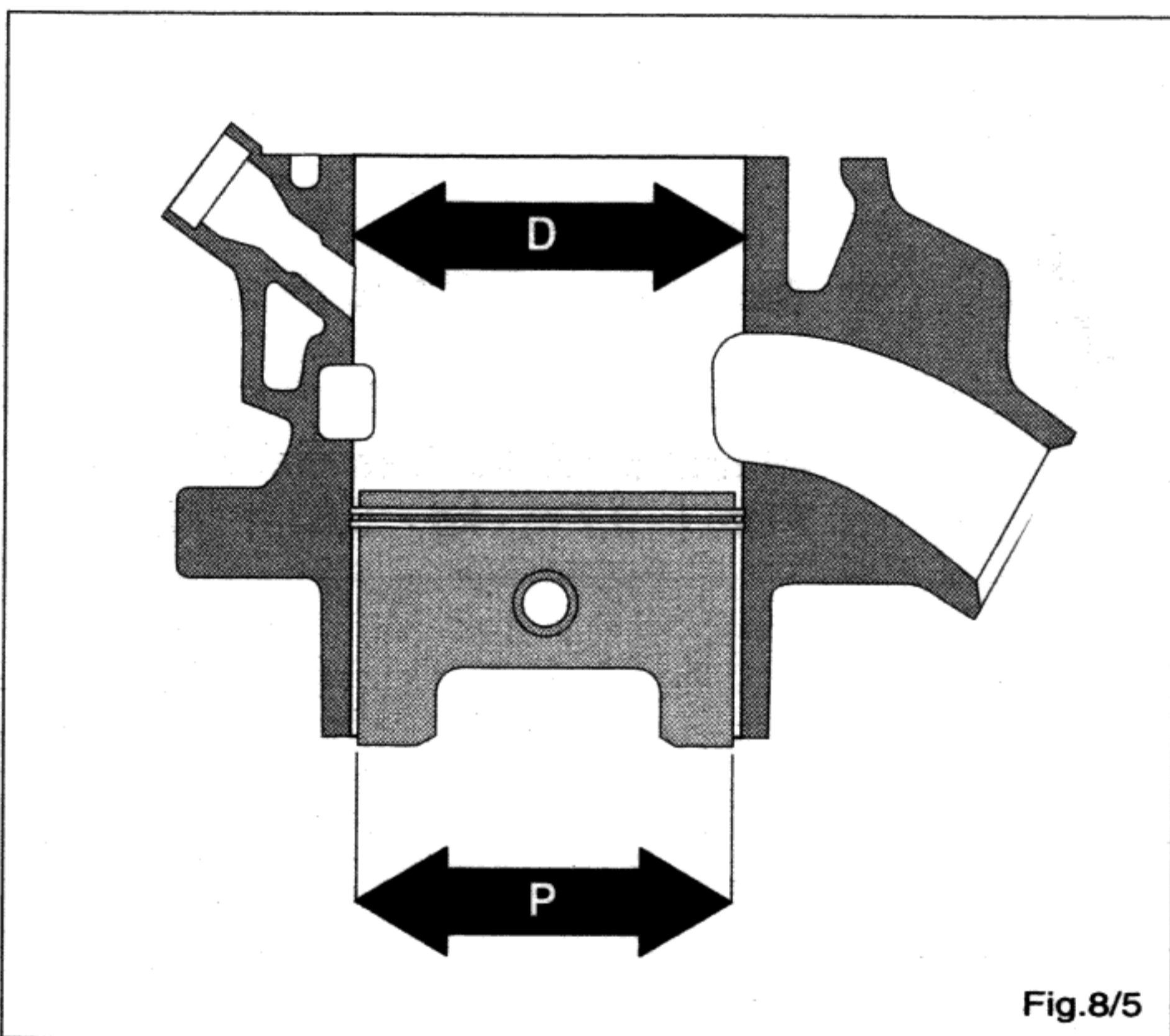

Fig.8/5

3. Misurare:
gioco del pistone
Fuori dalle specifiche ⇒ Ripristinare il cilindro
⇒ Sostituire il pistone



Gioco del pistone = D - P
D: alesaggio del cilindro
P: diametro esterno del pistone
0,024 ~ 0,055 mm.
(0,00094 ~ 0,0021 in)

Limite: 0,12 mm. (0,005 in),

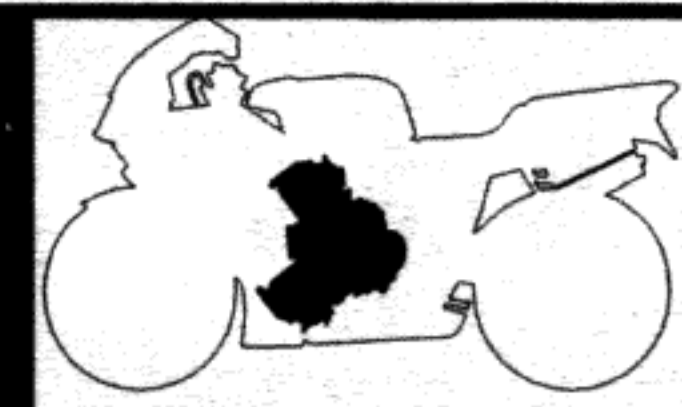

PISTON

1. Inspect:
Piston wall
2. Wear, scratches or damage ⇒ Replace.
Measure:
Piston outside diameter "P" (Use a micrometer)
Out of specification ⇒ Replace.

NOTE:

Measurement should be made at a point 15 mm (0.6 in) above the bottom edge of the piston.

NOTE:

The marks "1" for identifying the type of the piston is printed on the piston (Fig. 7/5).

Piston type	Outside diameter "P"
"A"	71,955 ~ 71,965 mm (2,8350 ~ 2,8354 in)
"B"	71,965 ~ 71,975 mm (2,8354 ~ 2,8358 in)

3. Measure:
Piston clearance
Out of specification ⇒ Rebore cylinder
⇒ Replace piston.



<p>Piston clearance = D - P D: cylinder bore P: piston outside diameter 0,024 ~ 0,055 mm. (0,00094 ~ 0,0021 in)</p>
<p>Limit: 0,12 mm. (0,005 in),</p>

KOLBEN

1. Prüfen:
Kolbenmantel
Abnutzung, Kratzer oder Beschädigung ⇒ Erneuern.
2. Messen:
Kolben-Außendurchmesser "P" (Ein Mikrometer verwenden)
Abweichung von Spezifikation ⇒ Erneuern.

HINWEIS:

Die Messung ist an einem Punkt vorzunehmen, der 15 mm (0,6 in) von der Unterkante des Kolbens entfernt ist.

HINWEIS:

Die Bez."1" für die Kennzeichnung des Kolbertyp ist rechts an der Kolber (Abb. 7/5).

Kolbentyp	Außendurchmesser "P"
"A"	71,955 ~ 71,965 mm (2,8350 ~ 2,8354 in)
"B"	71,965 ~ 71,975 mm (2,8354 ~ 2,8358 in)

3. Messen:
Kolbenspiel
Abweichung von Spezifikation ⇒ Zylinder aufbohren
⇒ Kolben erneuern.



<p>Kolbenspiel = D - P D: Zylinderbohrungsdurchmesser P: Kolben-Außendurchmesser 0,024 ~ 0,055 mm. (0,00094 ~ 0,0021 in)</p>
<p>Verschleißgrenze: 0,12 mm. (0,005 in),</p>

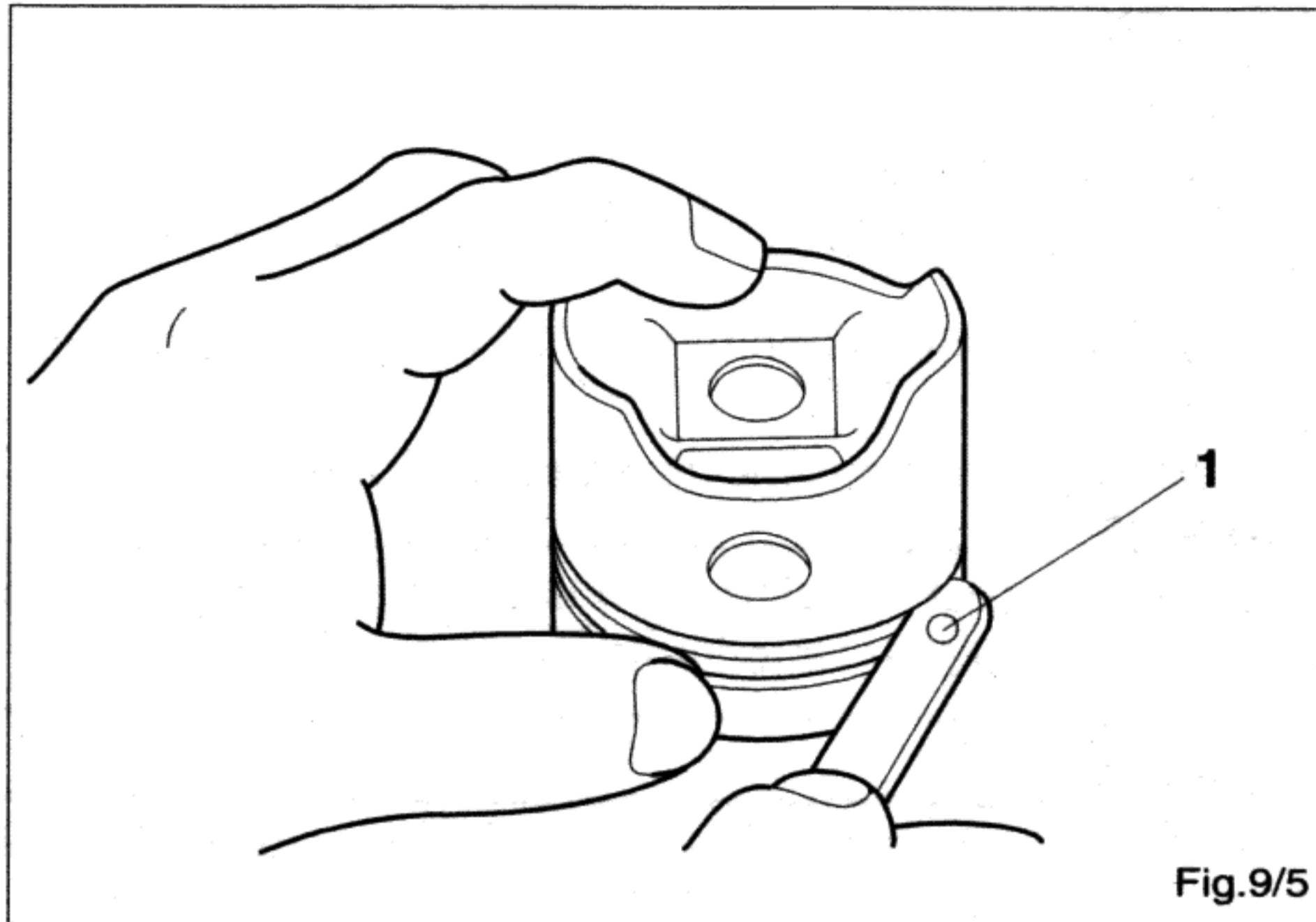
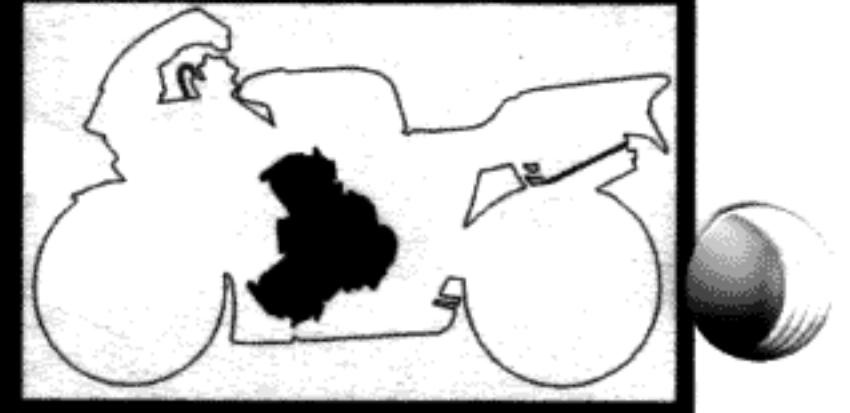

Fig.9/5

FASCE ELASTICHE

- Misurare:
gioco laterale della sede (usare spessimetro "1")
Fuori dalle specifiche ⇒ Sostituire pistone
⇒ Sostituire fasce elastiche

	Gioco laterale della sede:	
	Standard	Limite
Fascia superiore	0,070 ~ 0,025 mm. (0,0027 ~ 0,0001 in)	0,10 mm. (0,0039 in)
Fascia inferiore	0,070 ~ 0,025 mm. (0,0027 ~ 0,0001 in)	0,10 mm. (0,0039 in)

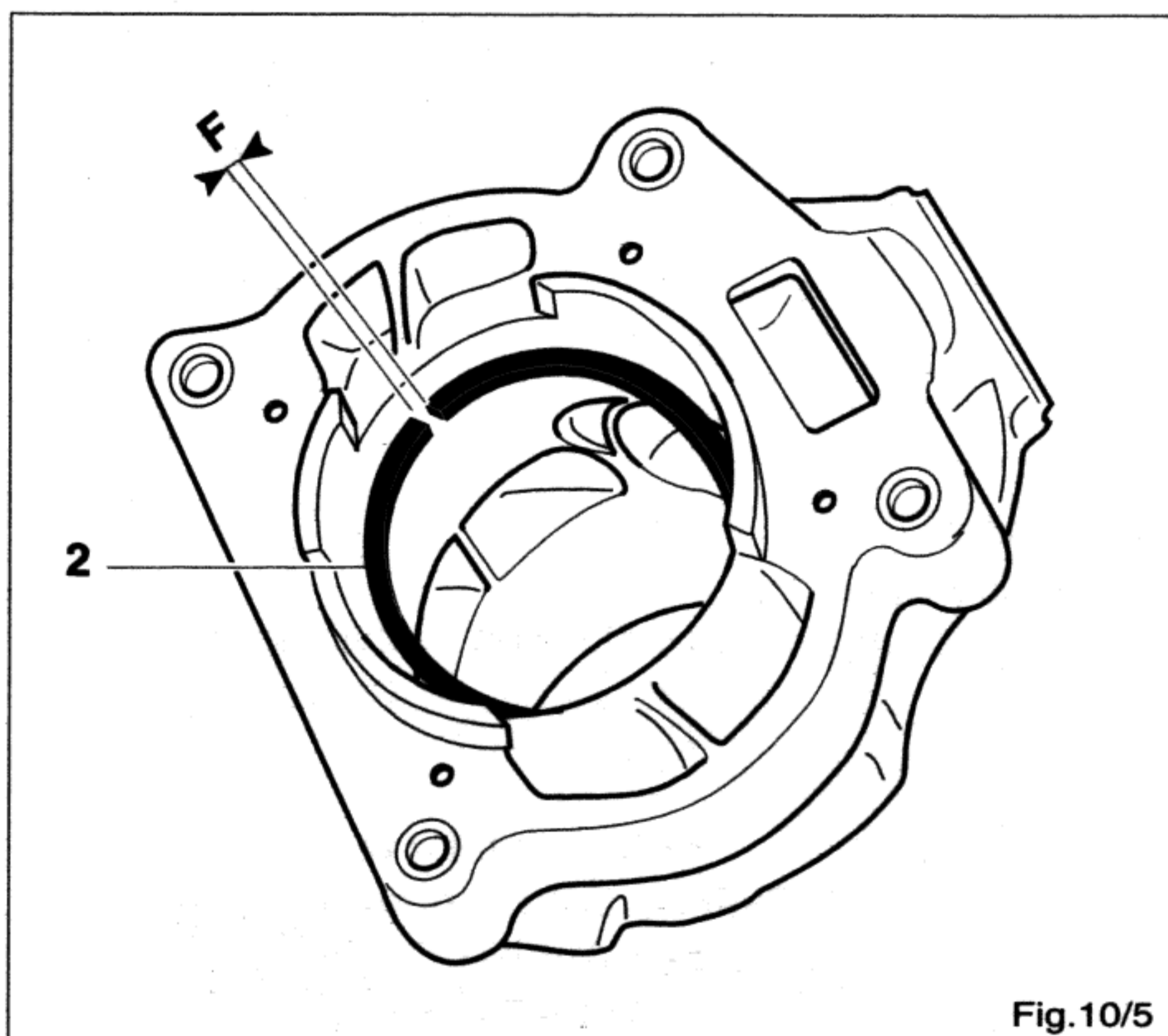
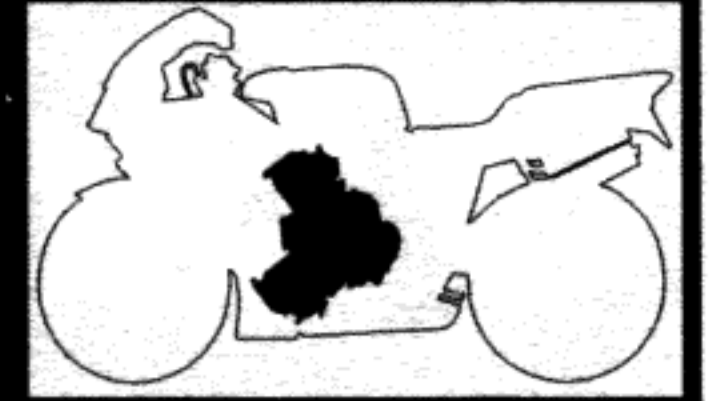

Fig.10/5

- Posizionare:
fascia elastica "2" nel cilindro
Spingere la fascia con la calotta del pistone.
- Misurare:
distanza delle estremità della fascia elastica (usare spessimetro)
Fuori dalle specifiche ⇒ Sostituire la fascia elastica

	Distanza delle estremità "F":	
	Standard	Limite
Fascia superiore	0,20 ~ 0,45 mm. (0,0078 ~ 0,018 in)	0,80 mm. (0,031 in)
Fascia inferiore	0,20 ~ 0,45 mm. (0,0078 ~ 0,018 in)	0,80 mm. (0,031 in)



PISTON RING

1. Measure:

Side clearance (Use feeler Gauge "1")
Out of specification ⇒ Replace piston
⇒ Replace rings

	Side clearance:	
	Standard	Limit
Top Ring	0,070 ~ 0,025 mm. (0,0027 ~ 0,0001 in)	0,10 mm. (0,0039 in)
2nd Ring	0,070 ~ 0,025 mm. (0,0027 ~ 0,0001 in)	0,10 mm. (0,0039 in)

2. Position:

Piston ring "2" (into cylinder)
Push the ring with the piston crown.

3. Measure:

End gap (Use feeler gauge).
Out of specification ⇒ Replace rings as set.

	End Gap "F":	
	Standard	Limit
Top Ring	0,20 ~ 0,45 mm. (0,0078 ~ 0,018 in)	0,80 mm. (0,031 in)
2nd Ring	0,20 ~ 0,45 mm. (0,0078 ~ 0,018 in)	0,80 mm. (0,031 in)

KOLBERINGE

1. Messen:

Seitliches Spiel (Eine Fühlerlehre "1" verwenden).
Abweichung von Spezifikation ⇒ Kolben erneuern
⇒ Kolbenringe erneuern.

	Seitliches Spiels:	
	Standard	Verschleißgrenze
Oberster Kolbelring	0,070 ~ 0,025 mm. (0,0027 ~ 0,0001 in)	0,10 mm. (0,0039 in)
Zweiter Kolbelring	0,070 ~ 0,025 mm. (0,0027 ~ 0,0001 in)	0,10 mm. (0,0039 in)

2. Einsetzen:

Kolbenring "2" (in Zylinder).
Den Kolbering mit dem Kolbenboden hineindrücken

3. Messen:

Kolbenring-Endspalt (Eine Fühlerlehre verwenden).
Abweichung von specification ⇒ Kolben-ringe als
satz euneuern.

	Endspalt "F":	
	Standard	Verschleißgrenze
Oberster Kolbelring	0,20 ~ 0,45 mm. (0,0078 ~ 0,018 in)	0,80 mm. (0,031 in)
Zweiter Kolbelring	0,20 ~ 0,45 mm. (0,0078 ~ 0,018 in)	0,80 mm. (0,031 in)

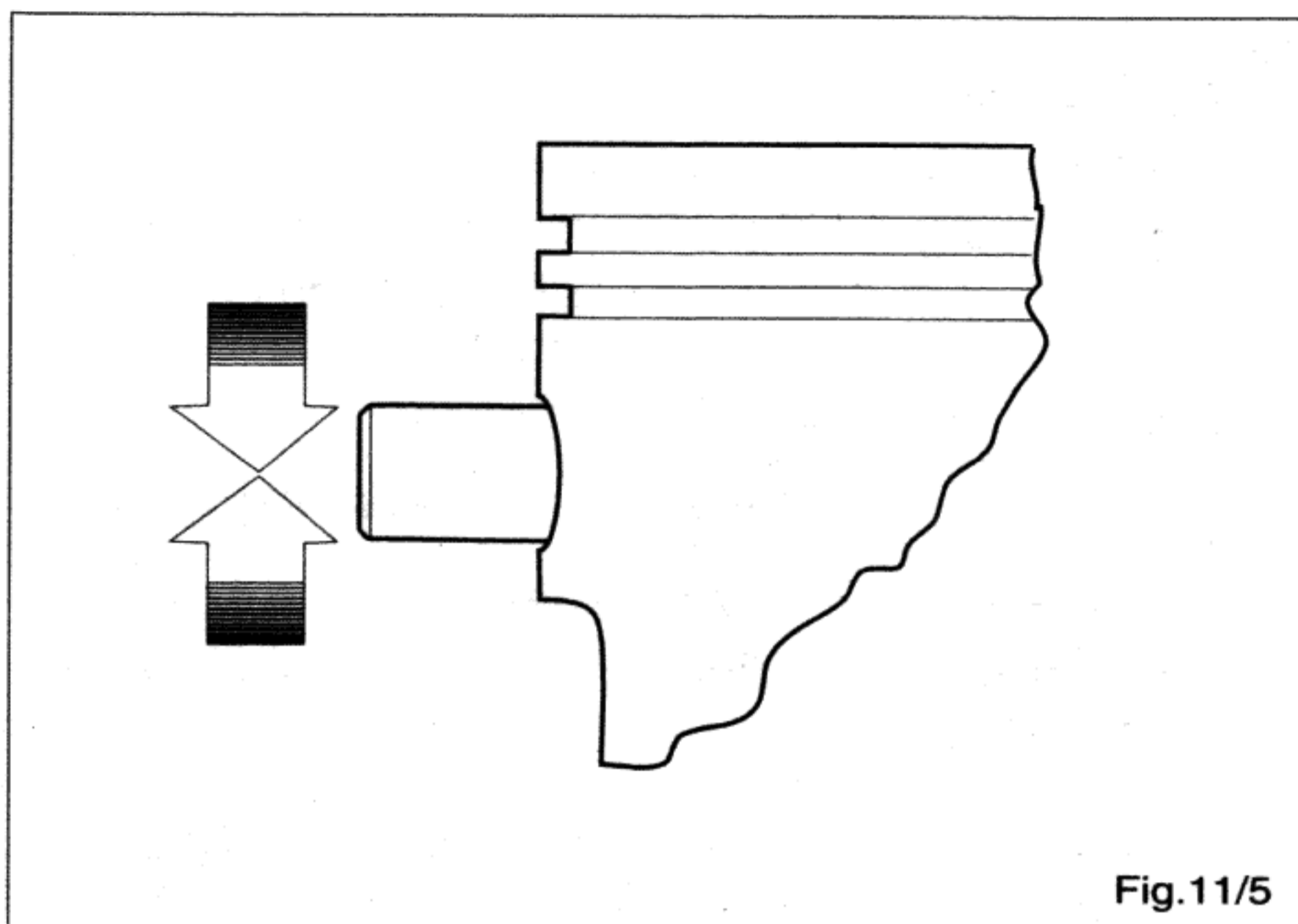
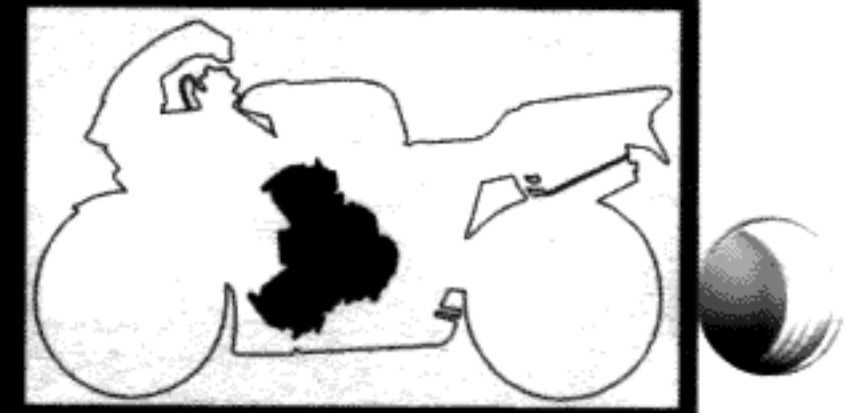

SPINOTTO PISTONE E CUSCINETTO DI BIELLA

1. Controllare:
 - spinotto pistone
 - cuscinetti di biella
 - Usura, rigatura o scoloratura termica ⇒ Sostituire spinotto pistone e il cuscinetto di biella insieme.
2. Posizione:
 - spinotto pistone (nel pistone)
3. Controllare:
 - gioco (spinotto montato sul pistone)
 - Gioco ⇒ Sostituire spinotto pistone
 - ⇒ Sostituire pistone

Fig.11/5

ALBERO MOTORE

1. Misurare:
 - centraggio (Usare prismi e comparatore)
 - Fuori dalle specifiche ⇒ Sostituire



Limite centraggio "A":
0,03 mm. (0,0012 in)

2. Misurare:
 - gioco (Usare comparatore)
 - Fuori dalle specifiche ⇒ Sostituire l'albero motore completo.



Limite di gioco al piede di biella "B":
2,0 mm. (0,08 in)

3. Misurare:
 - gioco laterale di biella (usare spessimetro)
 - Fuori dalle specifiche ⇒ Sostituire l'albero motore completo.



Limite del gioco laterale "C":
0,45 mm. (0,017 in)

4. Esaminare:
 - cuscinetti
 - bloccaggio o danneggiamento ⇒ Sostituire cuscinetti
 - ⇒ Sostituire l'albero motore completo.

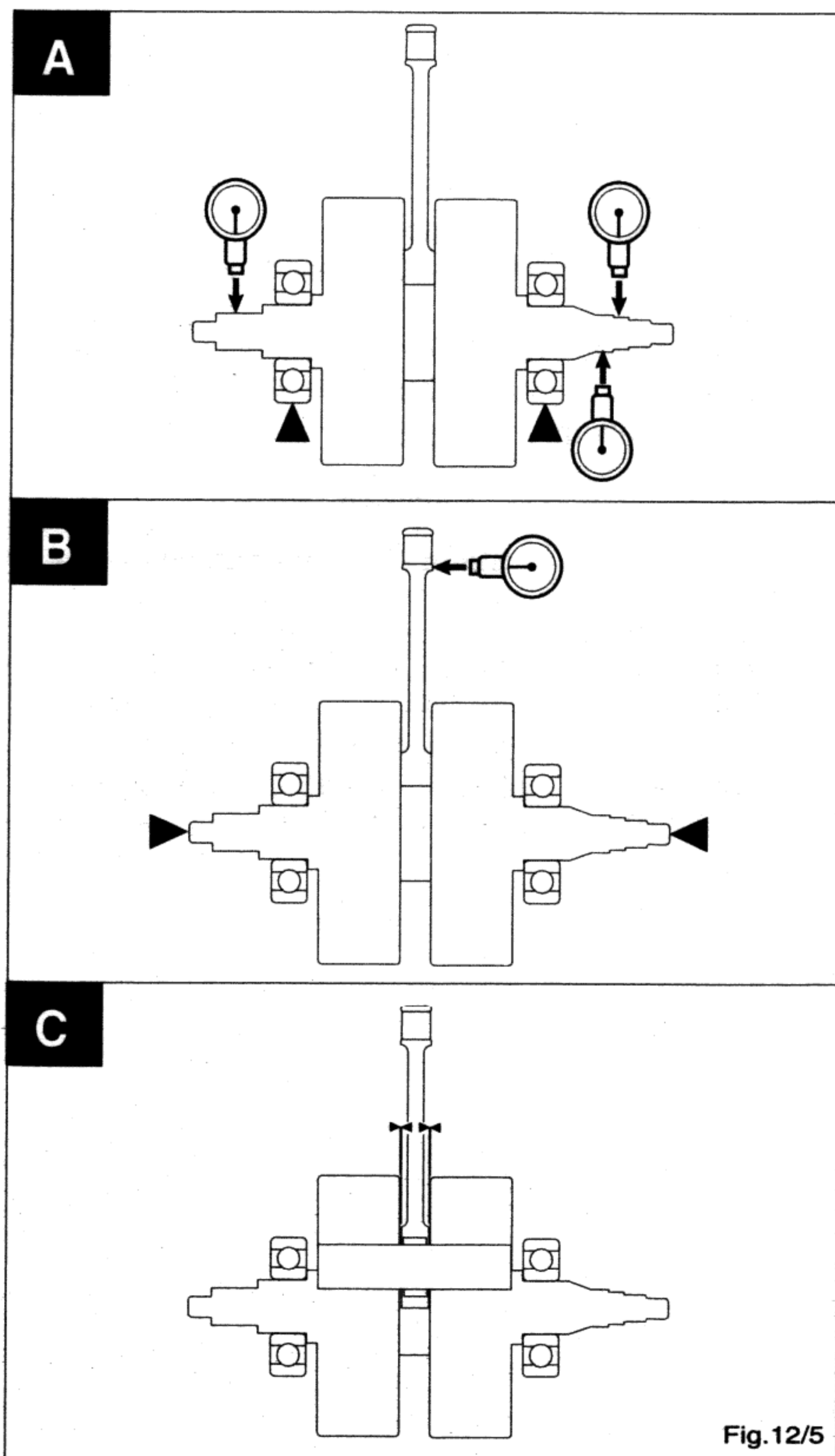
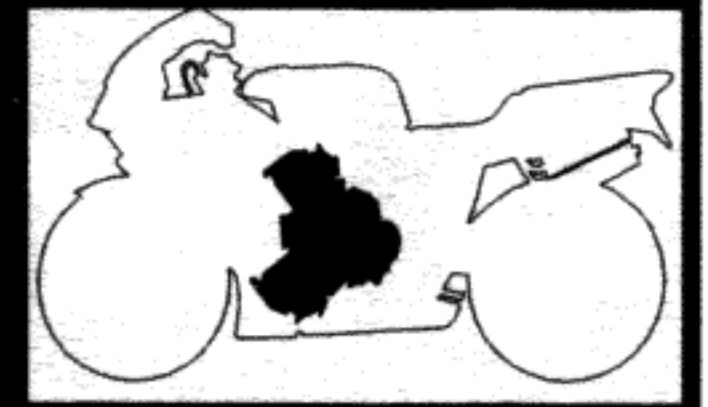

Fig.12/5



PISTON PIN AND CONECTING ROD BEARING

1. Check:
 - Piston pin
 - Connecting rod bearing
 - Wear, scratches or heat discoloration ⇒ Replace the piston pin and bearing as a set.
2. Position:
 - Piston pin (into piston)
3. Check:
 - Free play (when pin is in place in piston)
 - Free play ⇒ Replace piston pin ⇒ piston.

KOLBENBOLZEN UND PLEUELNGENLAGER

1. Prüfen:
 - Kolbenbolzen
 - Pleuelaugenlager
 - Abnutzung, Kratzer oden Hitzeverfärbung ⇒ Kolbenbolzen und Lager als Satz erneuern.
2. Einsetzen:
 - Kolbenbolzen (im Kolben)
3. Prüfen:
 - Spiel (Kolbenbolzen in Kolben)
 - Spiel vorhanden ⇒ Kolbenbolzen erneuern ⇒ Kolben erneuern.

CRANKSHAFT

1. Measure:
 - Runout (Use V-Blocks and Dial Gauge).
 - Out of specification ⇒ Replace.

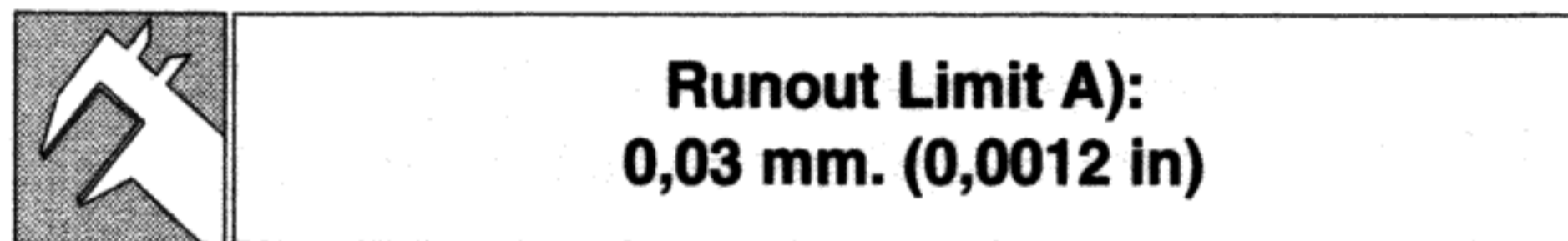

KURBELWELLE

1. Messen:
 - Schlag (V-Prismen und eine Me uhr verwenden).
 - Abweichung von der Spezifikation ⇒ Eneuern.

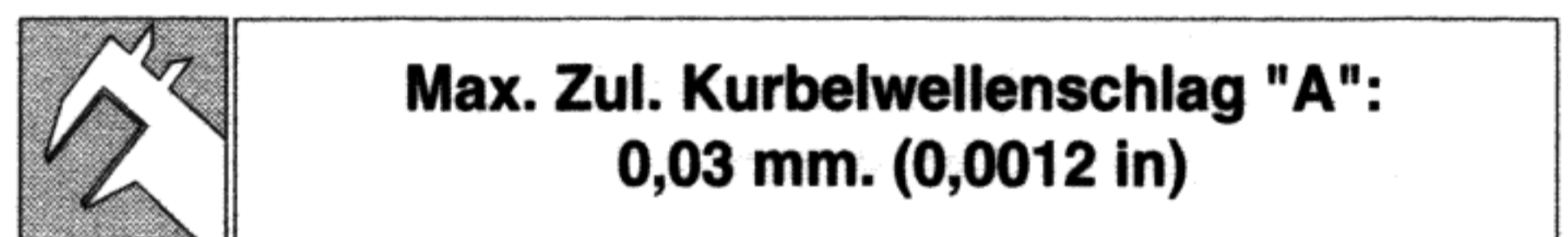

2. Measure:
 - Free play (Use the Dial Gauge).
 - Out of specification ⇒ Replace the crankshaft assembly.

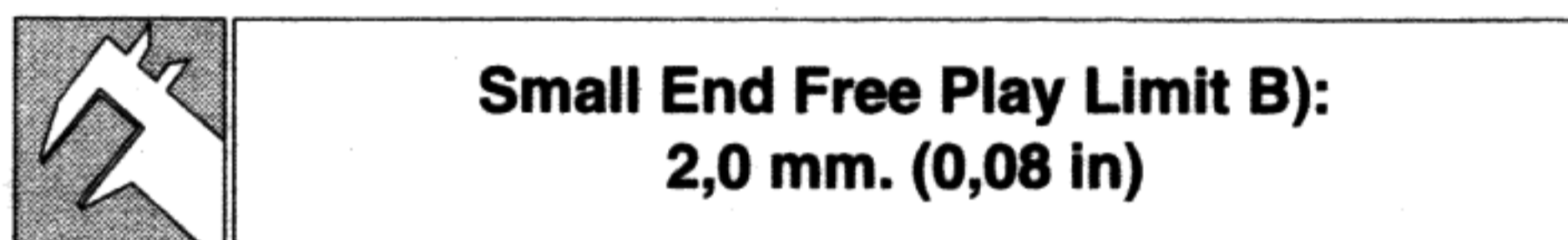

2. Messen:
 - Spiel (Eine Meßuhr werdenen).
 - Abweichung von der Spezifikation ⇒ Kurbelwelle erneuern.

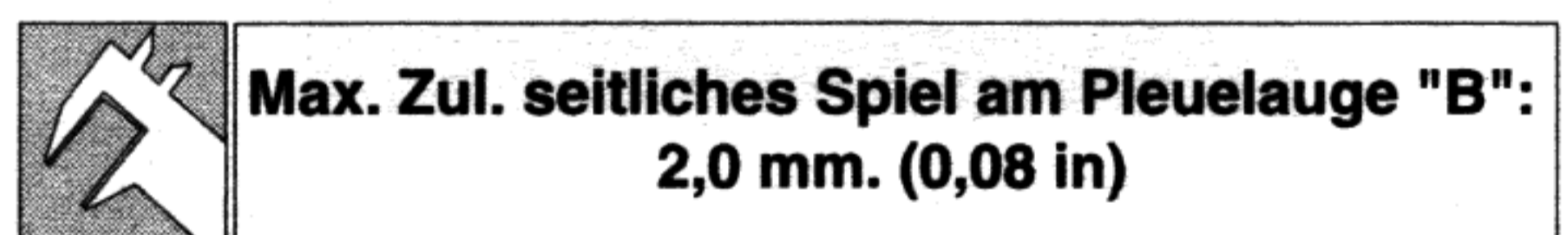

3. Measure:
 - Connecting rod side clearance (Use a feeler gauge).
 - Out of specification ⇒ Replace the crankshaft assembly.

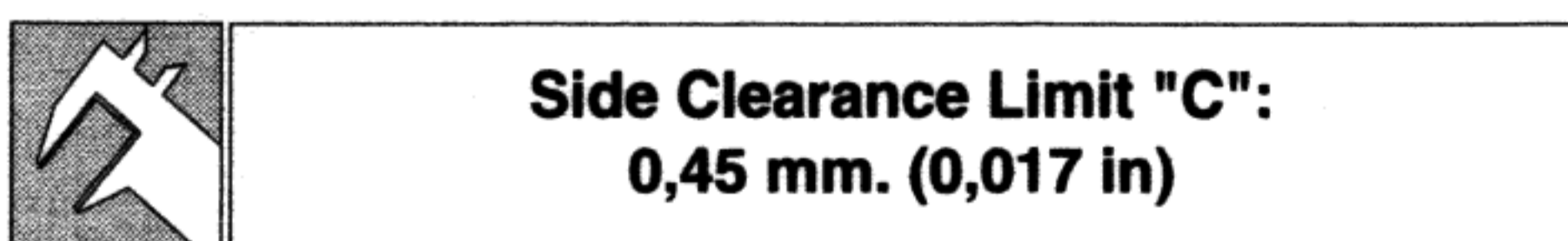

3. Messen:
 - Axialspiel am Pleuefuß (Eine Fühlerlehre verwenden)
 - Abweichung von der Spezifikation ⇒ Kurbelwelle erneuern.

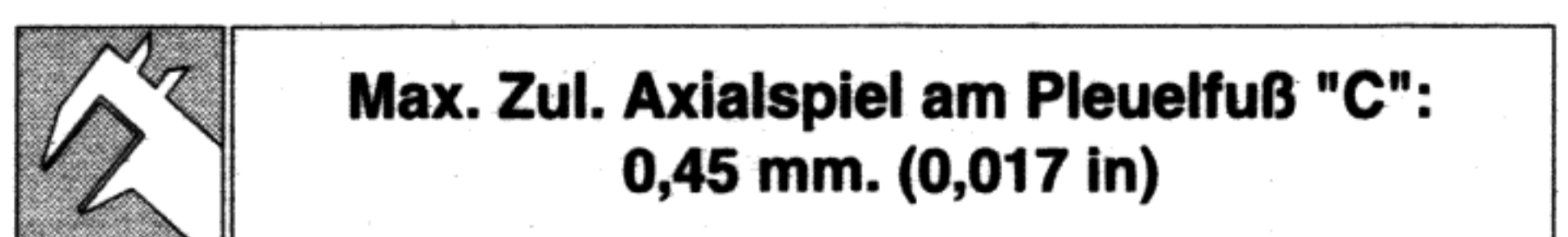

4. Inspect:
 - Bearings
 - Pitting or damage ⇒ Replace the bearing(s) ⇒ Crankshaft assembly.

4. Prüfen:
 - Lager
 - Grübchenfra or Besch digung ⇒ Lager erneuern ⇒ Kurbelwelleneinheit erneuern.

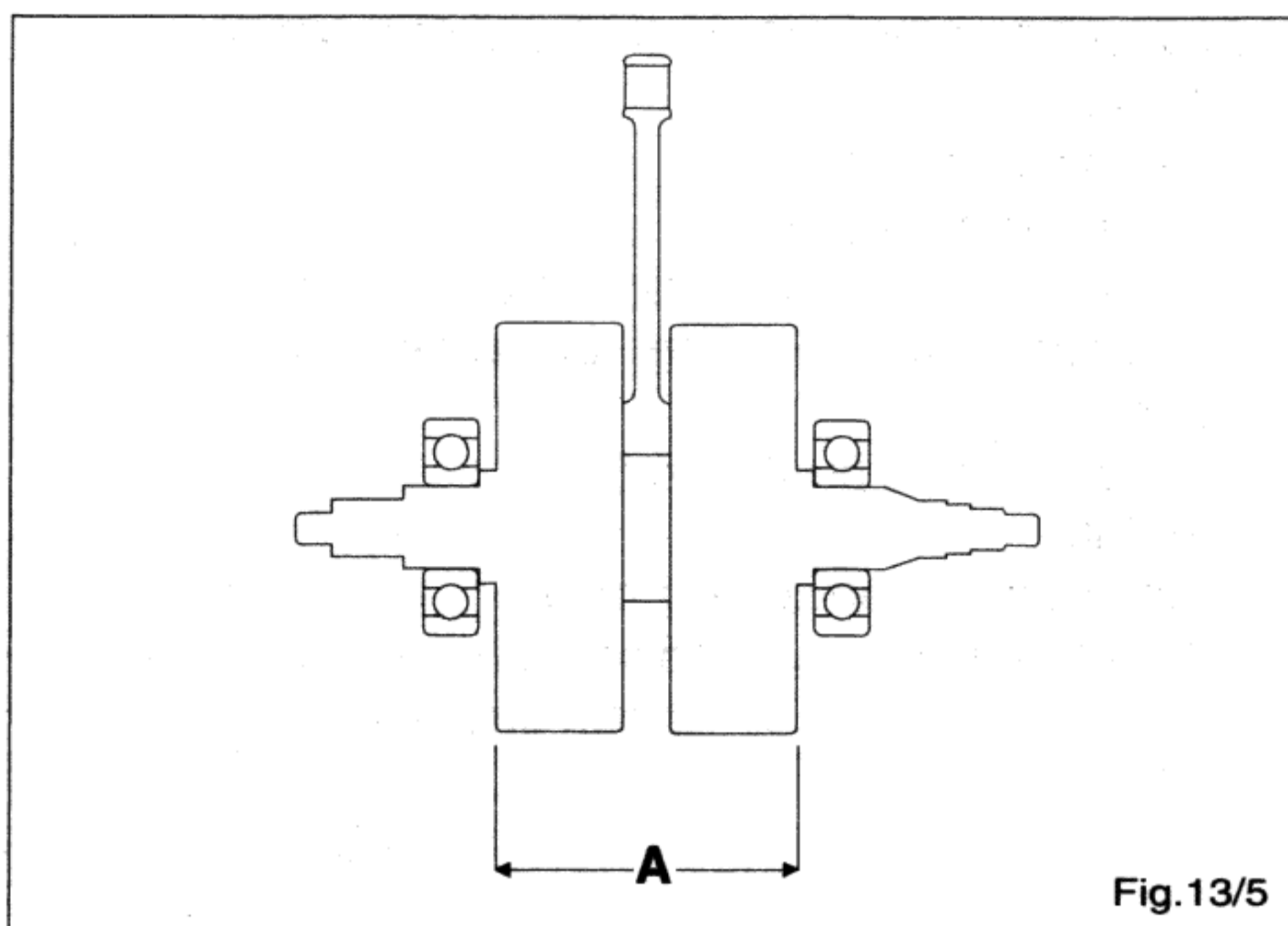
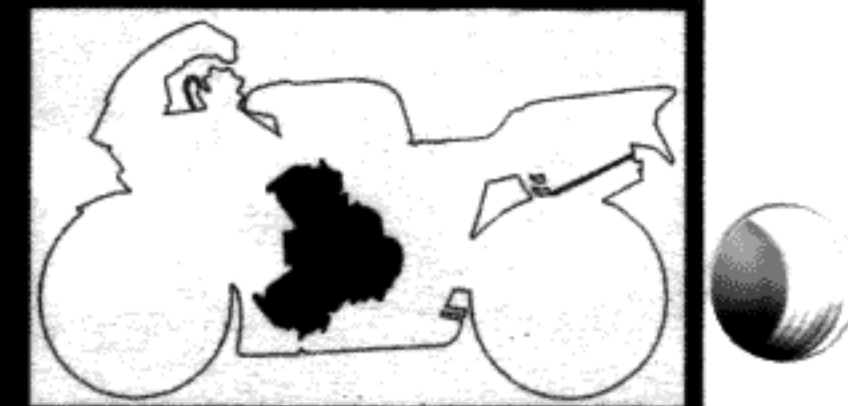

Fig.13/5

5. Verificare:
tolleranza larghezza albero motore
Fuori dalle specifiche ⇒ Sostituire



**Larghezza albero motore "D":
53 mm. (2,088 in)**

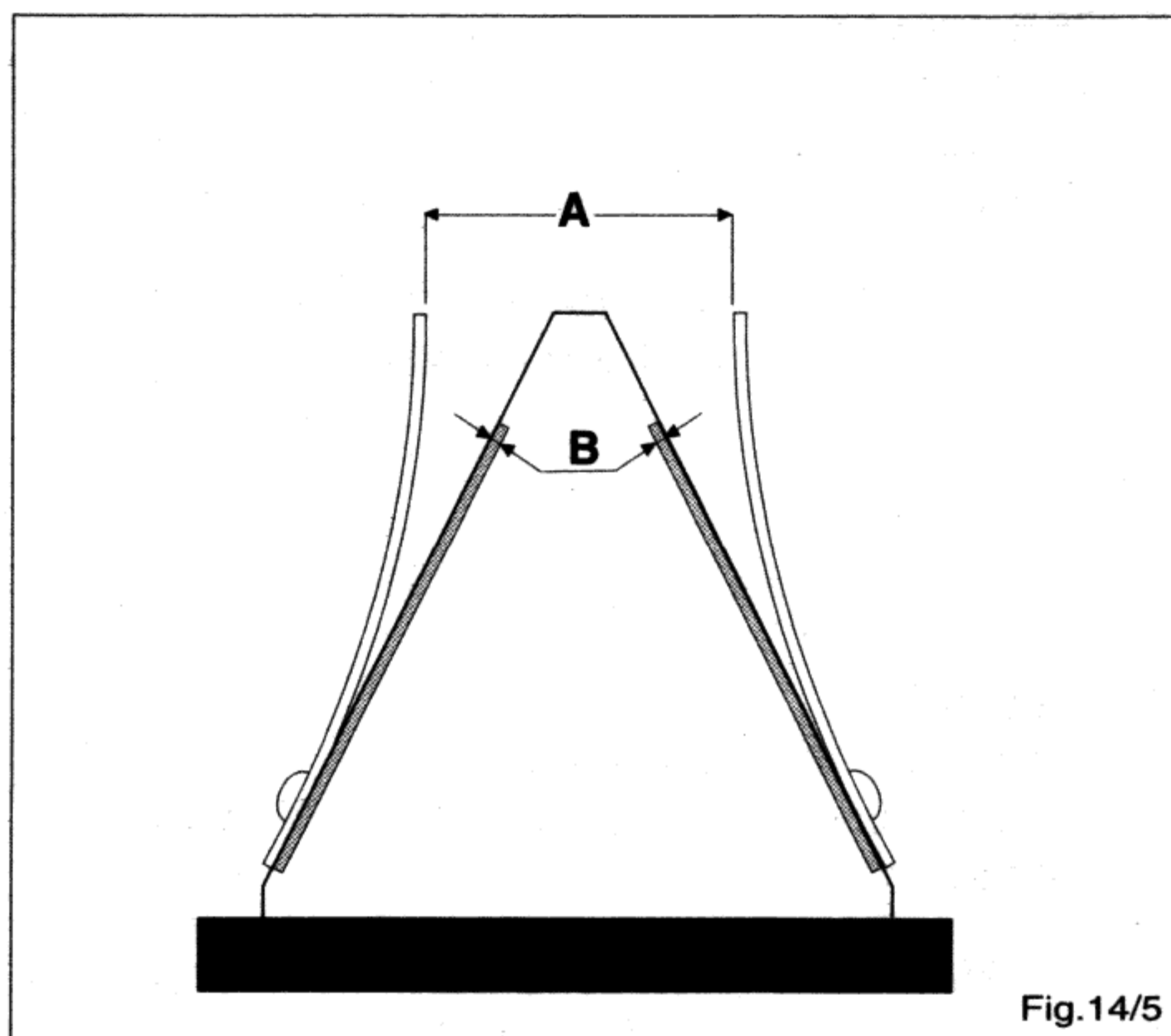

Fig.14/5

LAMELLE ASPIRAZIONE E RACCORDO CORPO

1. Misurare:
distanza "stopper" (fermi) lamelle
Fuori dalle specifiche ⇒ Sostituire



**Distanza "stopper" (fermi) lamelle "A":
23 ~ 24,5 mm: (0,906 ~ 0,965 in)**

2. Misurare:
spessore delle lamelle
Fuori dalle specifiche ⇒ Sostituire



**Limite spessore delle lamelle "B":
0,4 mm: (0,015 in)**

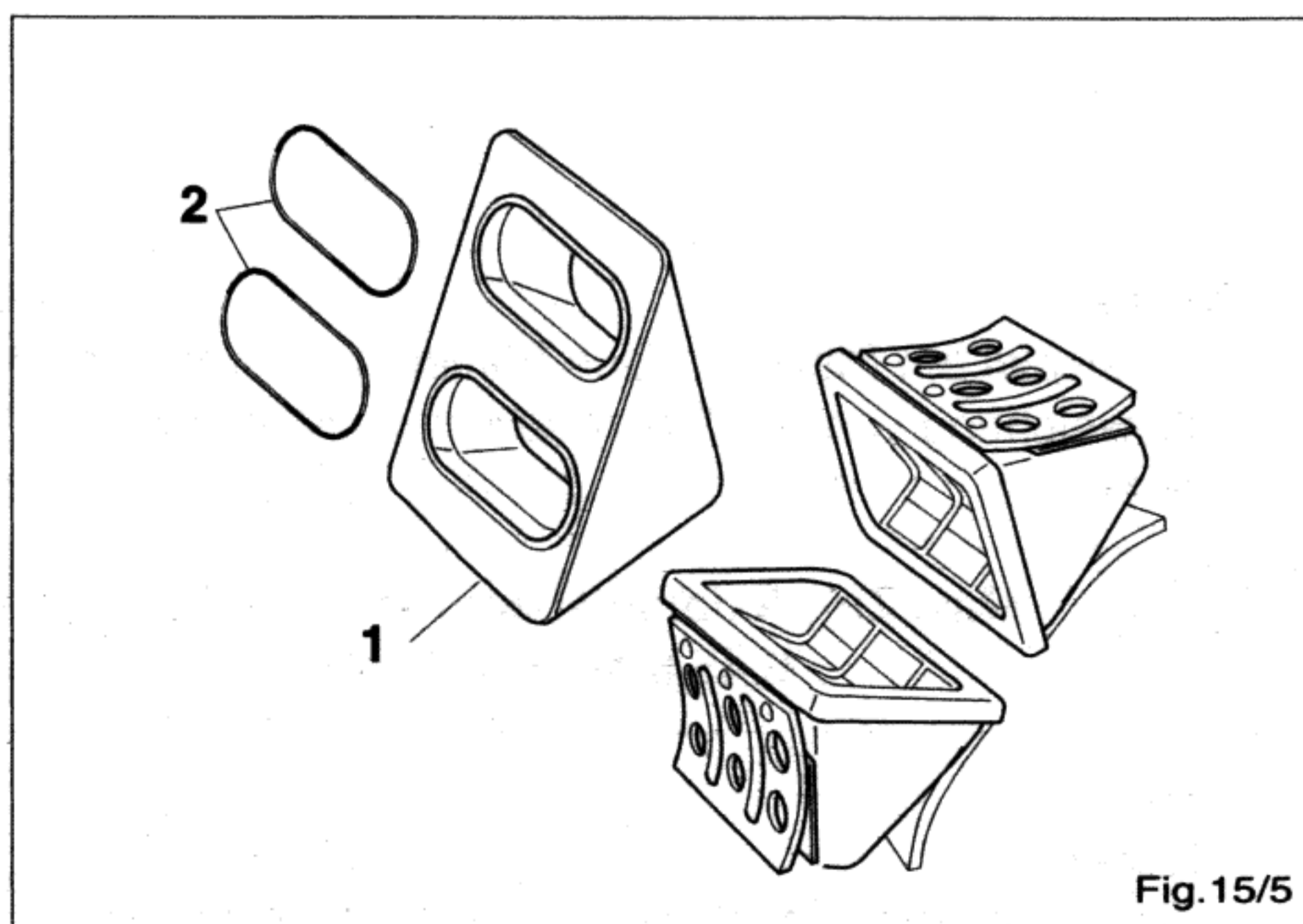
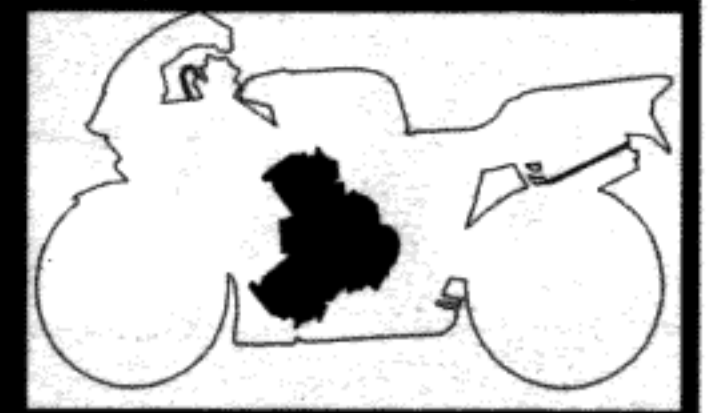

Fig.15/5

3. Esaminare:
raccordo corpo farfallato "1"
Fessure, usura o danneggiamento ⇒ Sostituire
O-Ring "2" (Qt. 2)
Danneggiamenti ⇒ Sostituire



5. Check:
crankshaft length
Out of specification ⇒ Replace.



Crankshaft length "D":
53 mm. (2,088 in)

5. Prüfen:
Kurbelwellenlänge
Abweichung von der Spezifikation ⇒ Erneuern.



Kurbelwellenlänge "D":
53 mm. (2,088 in)

REED VALVE AND HOUSING JOINT

1. Measure:
Valve stopper height
Out of specification ⇒ Replace.



Valve Stopper Height "A":
23 ~ 24,5 mm: (0,906 ~ 0,965 in)

2. Measure:
Valve bending
Out of specification ⇒ Replace.



Valve Bending Limit "B":
0,4 mm: (0,015 in)

ZUGENVENTIL UND KORPER-VERBINDUNG

1. Messen:
Ventilanschlaghöhe
Abweichung von der Spezifikation ⇒ Erneuern.



Ventilanschlaghöhe "A":
23 ~ 24,5 mm: (0,906 ~ 0,965 in)

2. Messen:
Biegung des Ventilschaftes
Abweichung von der Spezifikation ⇒ Erneuern.



Max. Zul. Biegung des Ventilschaftes "B":
0,4 mm: (0,015 in)

3. Inspect:
housing joint "1"
Cracks, wear or damage ⇒ Replace.
O-Rings "2"(Qt.2)
Damage ⇒ Replace.

3. Prüfen:
Körper-Verbindung "1"
Risse, Abnutzung oder Beschädigung ⇒ Erneuern.
O-Ringe "2"(Zahl 2)
Beschädigung ⇒ Erneuern.

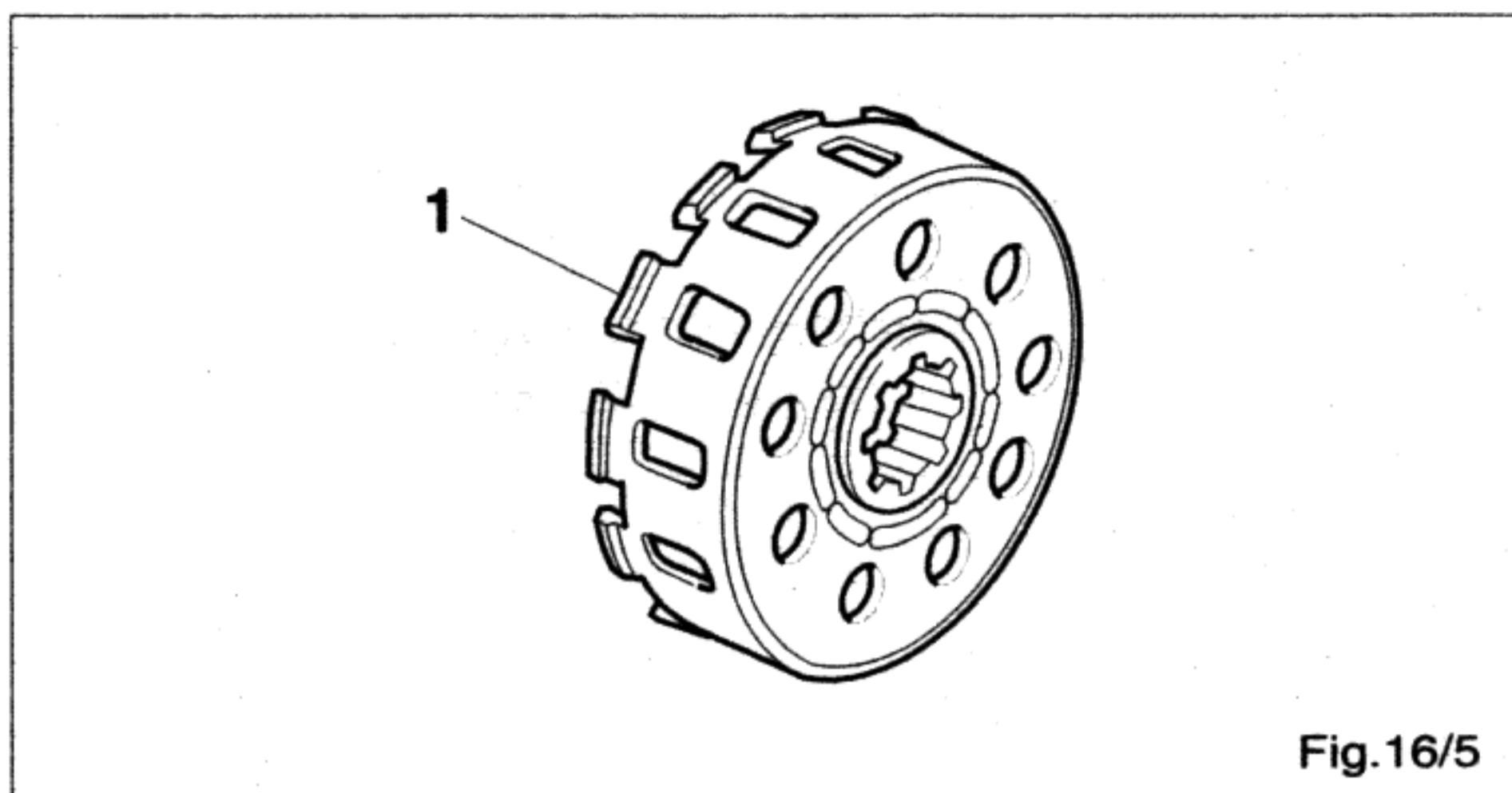
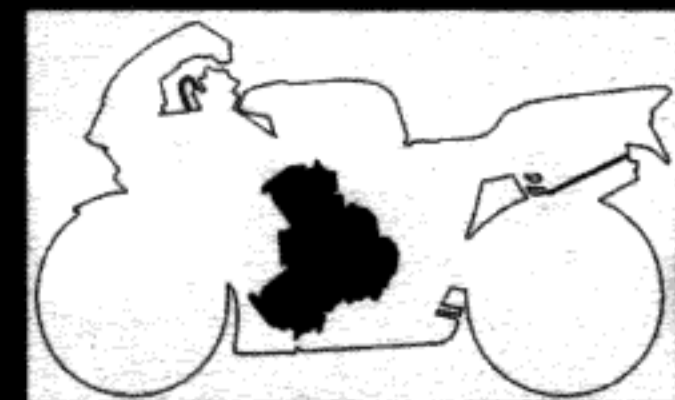

Fig.16/5

FRIZIONE

1. Esaminare:

denti "di lupo" della campana frizione "1"

Crepature, usura o danneggiamenti ⇒ Sbavare
⇒ Sostituire

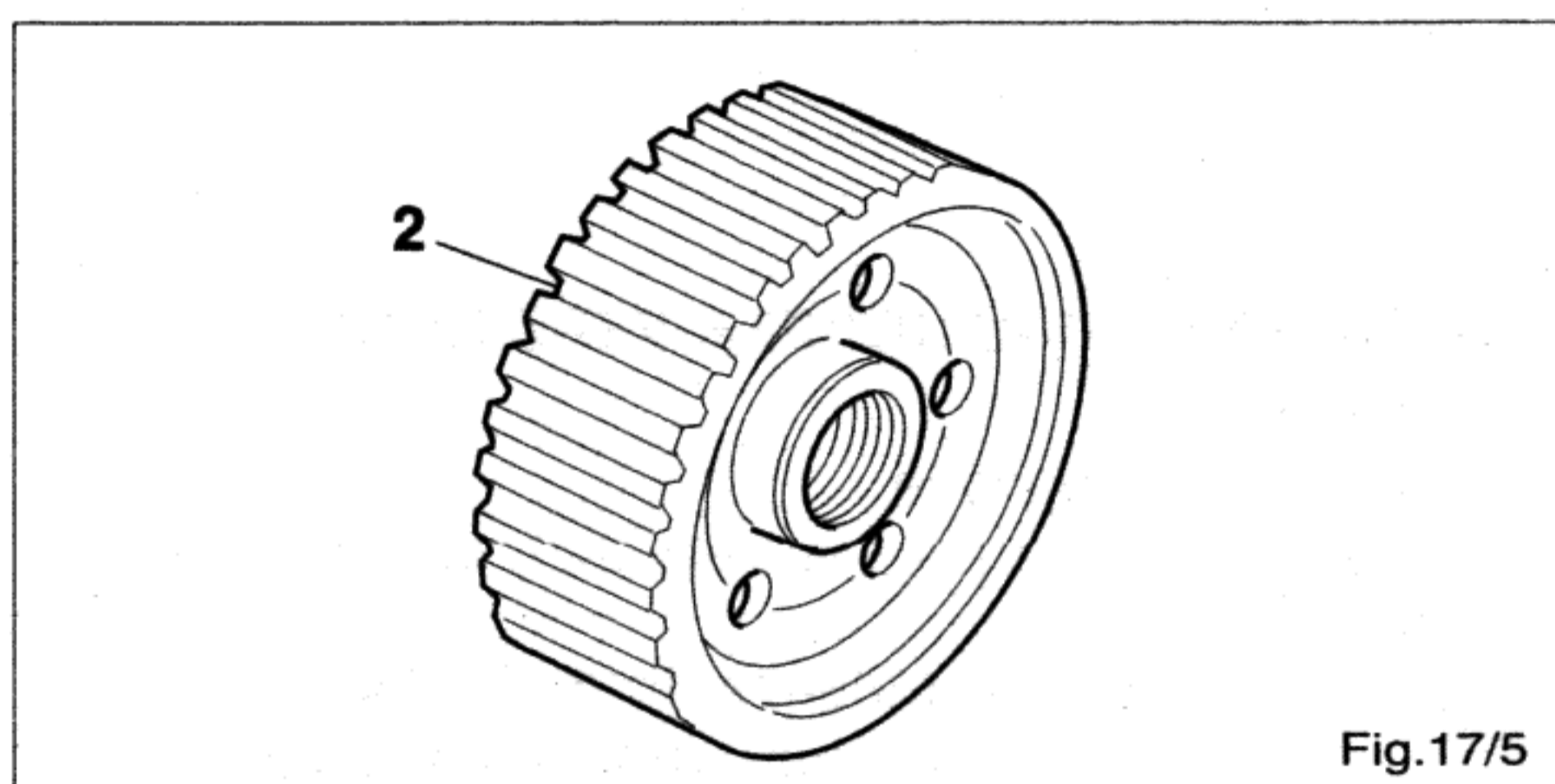

Fig.17/5

2. Esaminare:

canali del tamburo frizione "2"

Striature, usura o danneggiamenti ⇒ Sostituire l'in-
tero gruppo

NOTA:

La presenza di scanalature nelle canalizzazioni per i
dischi frizione può causare un funzionamento irregolare.

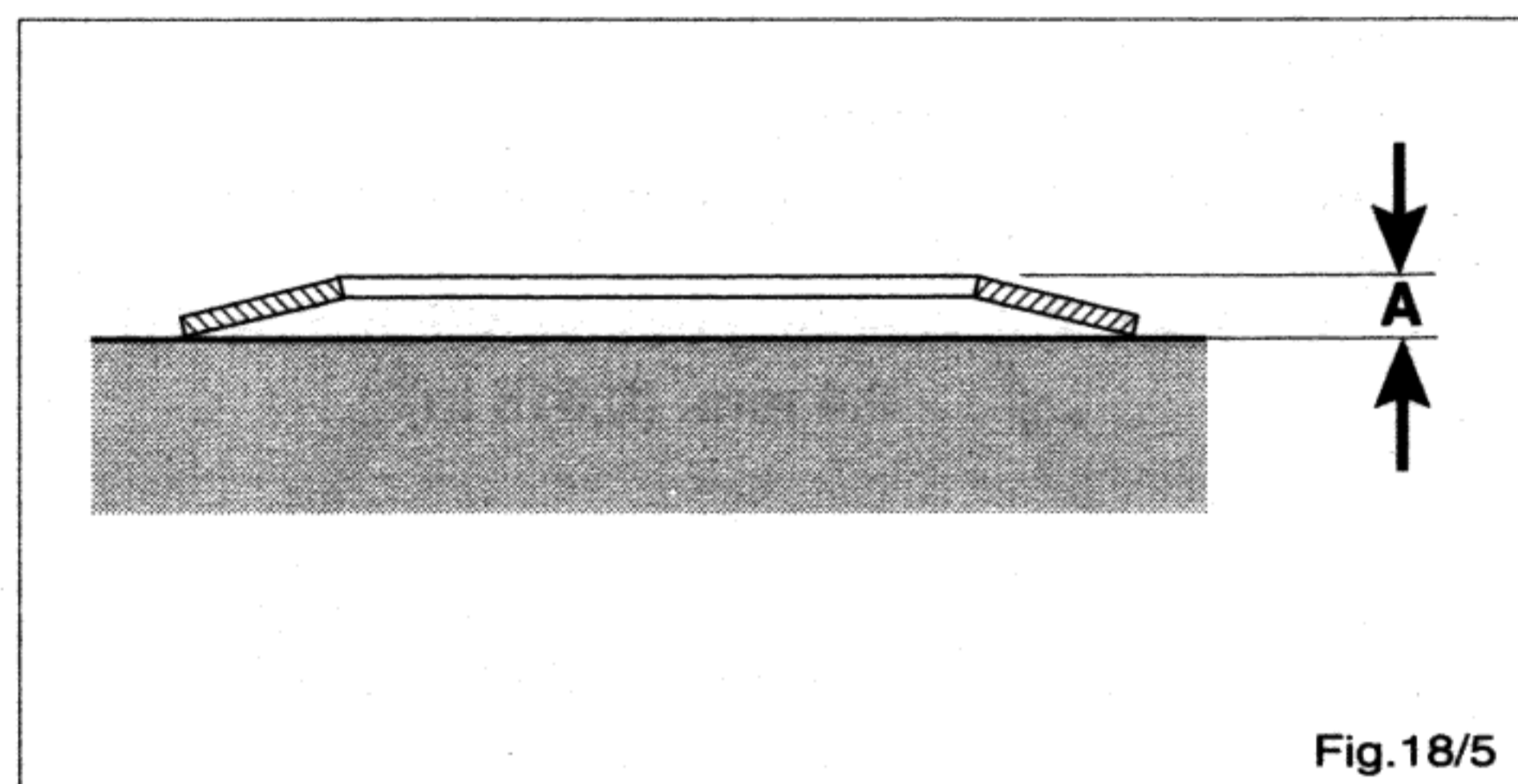

Fig.18/5

3. Misurare:

Altezza molla di carico "A"

Fuori dalle specifiche ⇒ Sostituire molla di carico



Altezza molla di carico "A":
0,4 ~ 0,8 mm. (0,015 ~ 0,031 in)

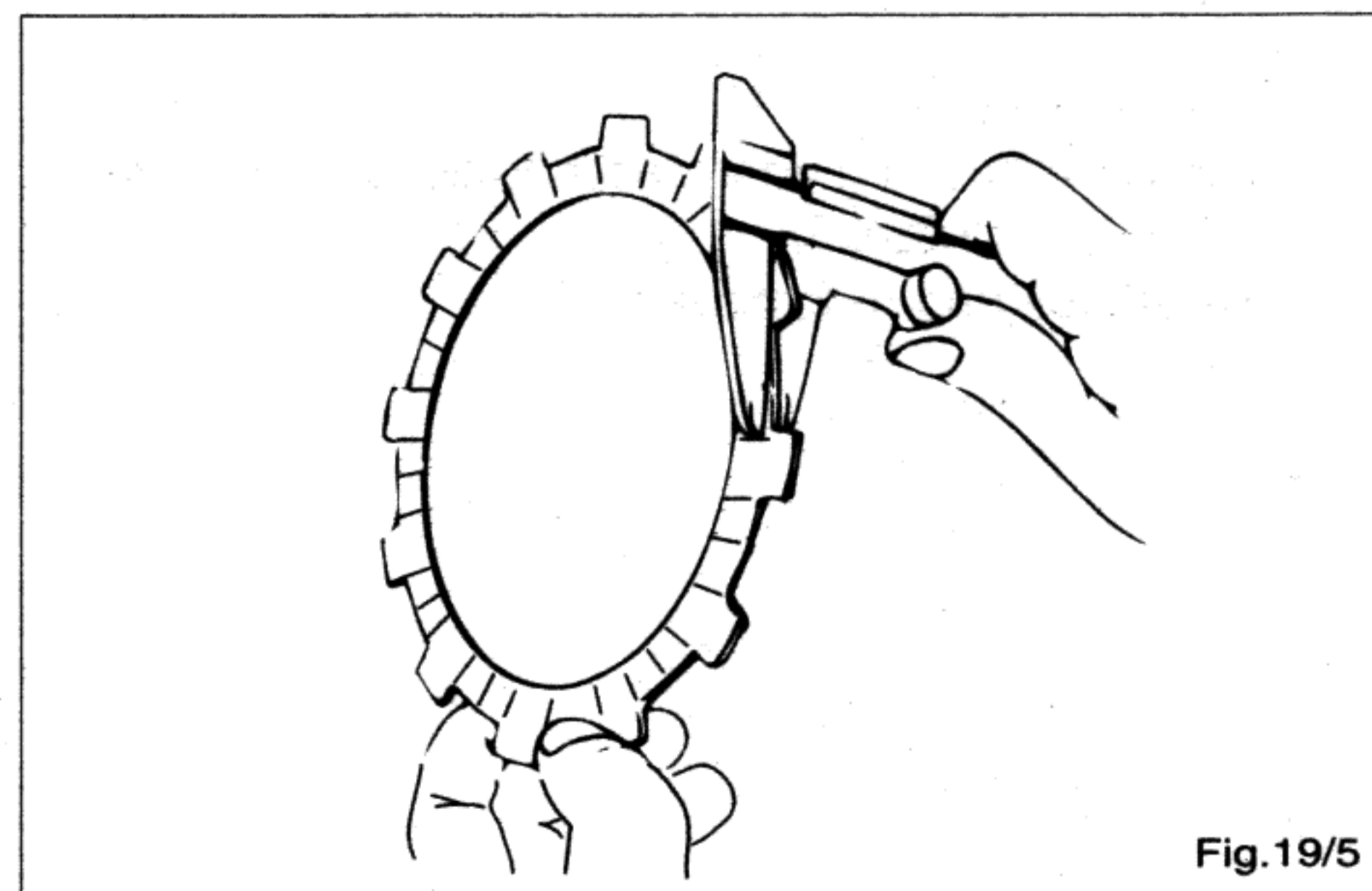

Fig.19/5

4. Misurare:

spessore dei dischi frizione "B" (Misurare in 4 punti)

Fuori dalle specifiche ⇒ Sostituire tutto il set di dischi



Spessore dei dischi frizione "B":
2,3 mm. (0,08 in)

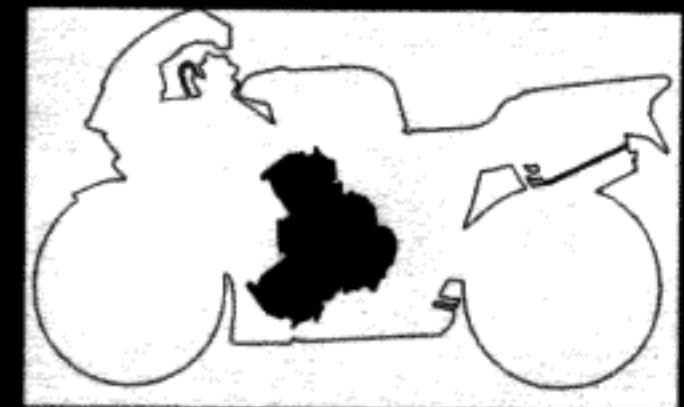

CLUTCH

1. Inspect:

- Dogs on the housing "1".
- Cracks, wear or damage ⇒ Deburr
⇒ Replace.

2. Inspect:

- Clutch boss splines
- Scoring, wear or damage ⇒ Replace clutch boss assembly.

NOTE:

Scoring on the clutch plate splines will cause erratic operation.

3. Measure:

- spring-plate weight "A"
- Out of specification ⇒ Replace spring-plate



Spring-plate weight "A":
0,4 ~ 0,8 mm. (0,015 ~ 0.031 in)

4. Measure:

- Friction plate "B" thickness (Measure at all four points)
- Out of specification ⇒ Replace friction plate as set.



Wear Limit "B":
2,3 mm. (0,08 in)

KUPPLUNG

1. Prüfen:

- Mitnehmerklauen im Gehäuse "1"
- Risse, Abnutzung oder Beschädigung ⇒ Entgraten
⇒ Erneuern.

2. Prüfen:

- Kupplungs-naben-Keinuten
- Ausbrüche, Abnutzung oder Beschädigung ⇒ Die Kupplungs-nabe erneuern.

HINWEIS:

Ausbrüche an den Kupplungs-scheiben-Keilnuten führen zu ruckartiger Kupplungsfunktion.

3. Messen:

- Kupplungsschreibenlänge "A"
- Abweichung von Spez. ⇒ Kupplungsschreibe erneuern.



Min. Zul. Kupplungsschreibenlänge "A":
0,4 ~ 0,8 mm. (0,015 ~ 0.031 in)

4. Messen:

- Reibscheibenstärke "B" (An vier Punkten am Umfang messen).
- Abweichung von Spezifikation ⇒ Die Reibscheiben als Satz erneuern.



Verschleißgrenze "B":
2,3 mm. (0,08 in)

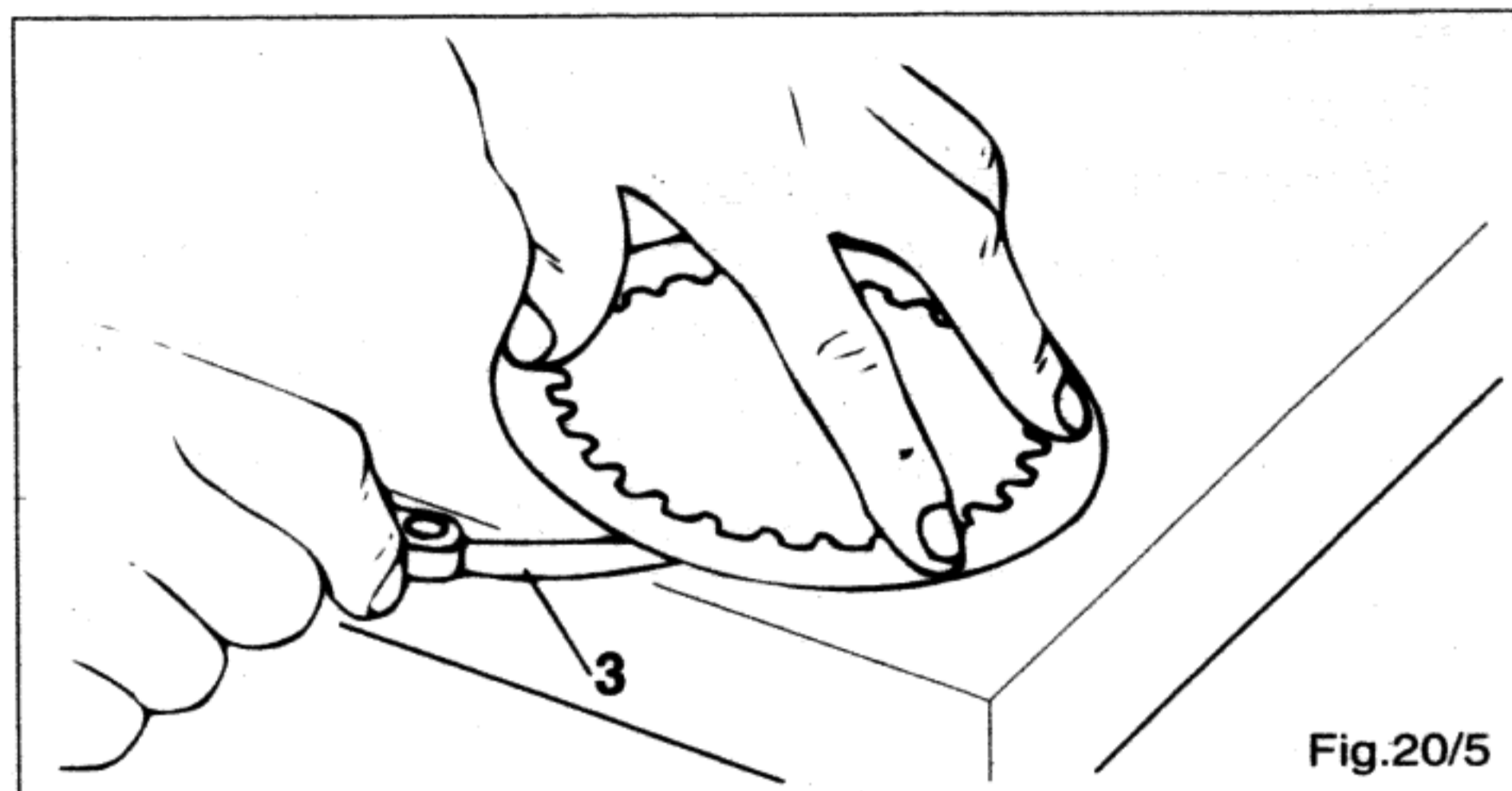
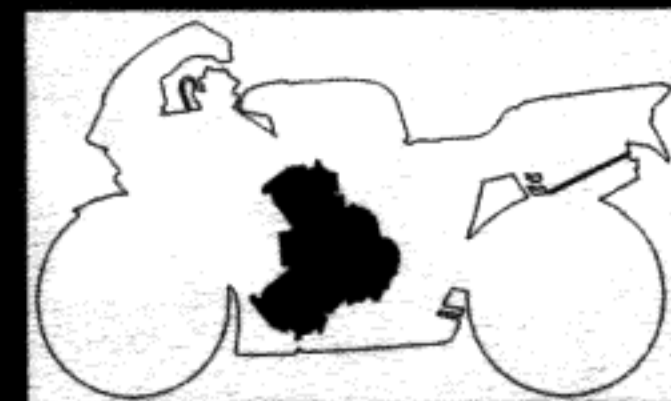

Fig.20/5

5. Misurare:
deformazione dei piatti frizione (Utilizzare un piano di
riscontro e uno spessimetro "3").
Fuori dalle specifiche ⇒ Sostituire



Limite deformazione dei piatti frizione :
0.2 mm. (0.08 in)

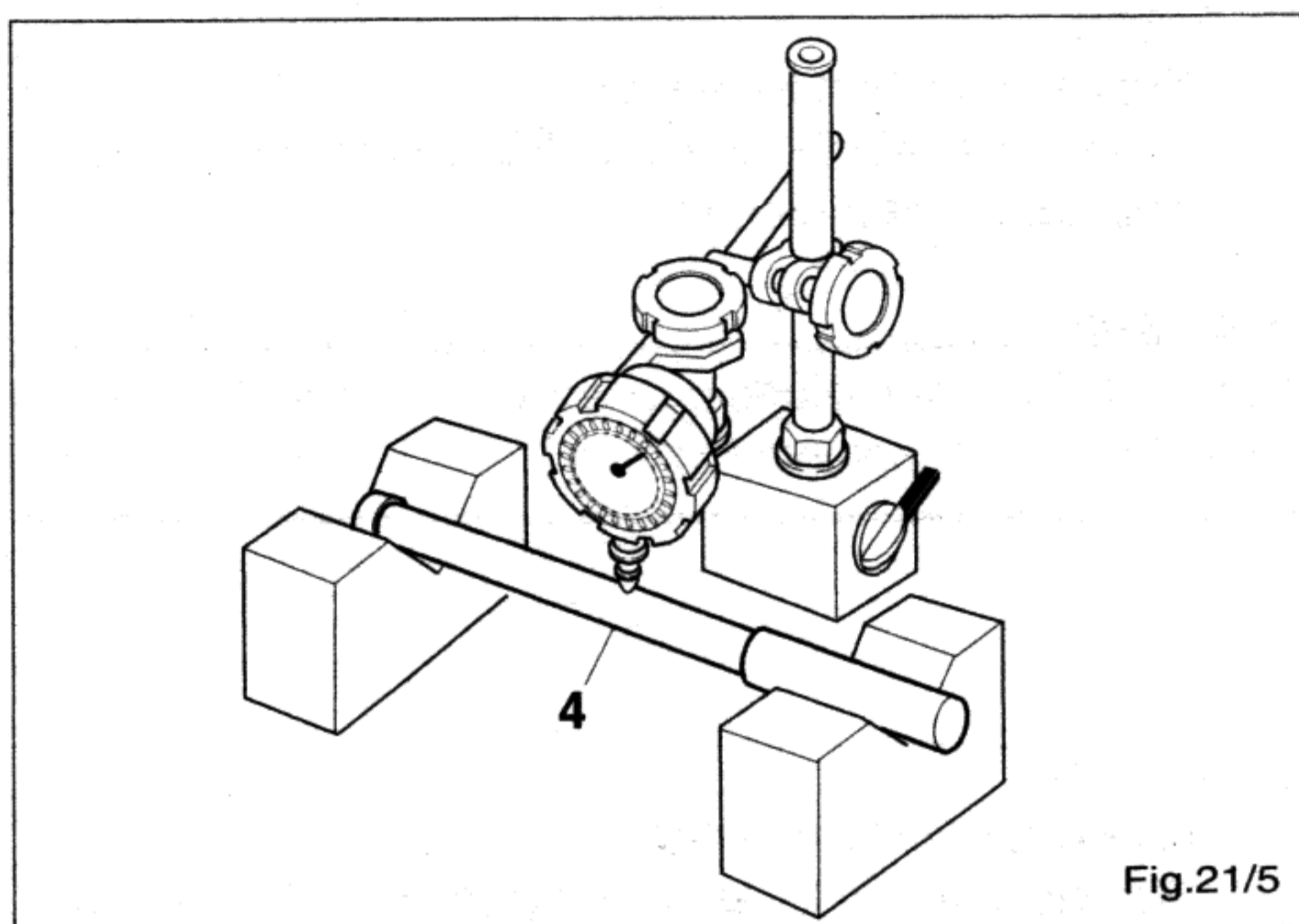

Fig.21/5

6. Misurare:
centraggio asta spingidisco "4" (la più lunga)
(utilizzare prismi e comparatore)
Fuori dalle specifiche ⇒ Sostituire



Limite centraggio asta spingidisco :
0,5 mm. (0,020 in)

7. Esaminare:
O-Ring (montato su asta spindidisco corta)
Usura, rotture o danneggiamenti ⇒ Sostituire

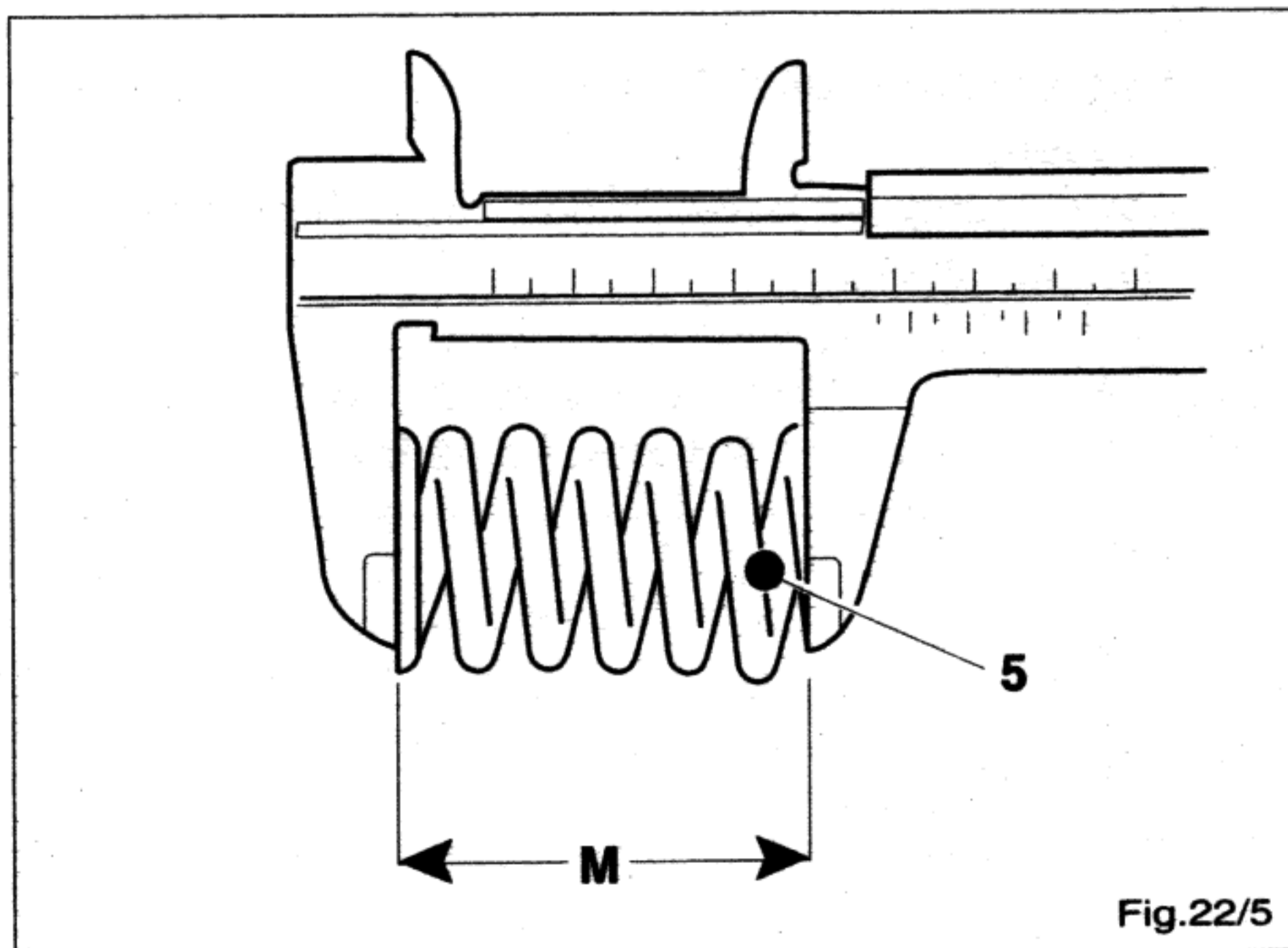
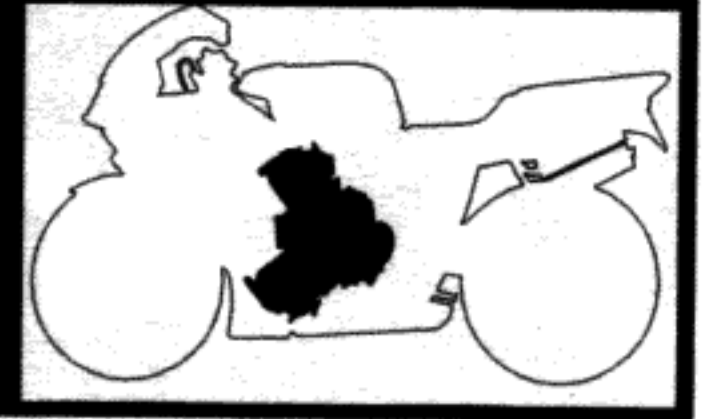

Fig.22/5

8. Esaminare:
molla frizione "5"
Usura, deformazione o rotture ⇒ Sostituire
9. Misurare:
lunghezza molla frizione
Fuori dalle specifiche ⇒ Sostituire tutte le molle frizione insieme.



Lunghezza minima molla frizione "M":
38.2 ~ 40,2 mm. (1,57 ~1,58 in)



5. Measure:
Clutch plate warpage (Use surface plate and Feeler Gauge "3").
Out of specification ⇒ Replace.



Warp Limit Friction plate:
0.2 mm. (0.08 in)

5. Messen:
Verzug der Kupplungsscheiben (Eine Richtplatte und eine Fühlerlehre "3" verwenden).
Abweichung von Spezifikation ⇒ Erneuern.



Max. Zul. Verzug:
0.2 mm. (0.08 in)

6. Measure:
Push rod runout "4" (long rod)
(Use V-Blocks and Dial Gauge)
Out of specification ⇒ Replace.



Bending Limit Push rod :
0,5 mm. (0,020 in)

6. Messen:
Schlag der Schubstange "4" (Lange Stange)
(V-Prismen und eine Meßuhr verwenden).
Abweichung von Spezifikation ⇒ Erneuern.



Max. Zul. Schlag :
0,5 mm. (0,020 in)

7. Inspect:
O-ring (on short rod)
Wear, cracks or damage ⇒ Replace.

7. Prüfen:
O-ring (an Kurzer Stange)
Abnutzung, Risse oder Beschädigung ⇒ Erneuern.

8. Inspect:
Clutch spring "5"
Wear, bends or cracks ⇒ Replace.

9. Measure:
Clutch spring free length
Out of specification ⇒ Replace springs as a set.



Clutch Spring Minimum Length "M":
38.2 ~ 40,2 mm. (1,57 ~1,58 in)

8. Prüfen:
Kupplungsfeder "5"
Verschleiß, Biegung oder Risse ⇒ Erneuern.

9. Messen:
Ungespannte Federlänge
Abweichung von Spezifikation ⇒ Die Federn als Satz erneuern.



Min. Zul. Kupplungsfederlänge "M":
38.2 ~ 40,2 mm. (1,57 ~1,58 in)

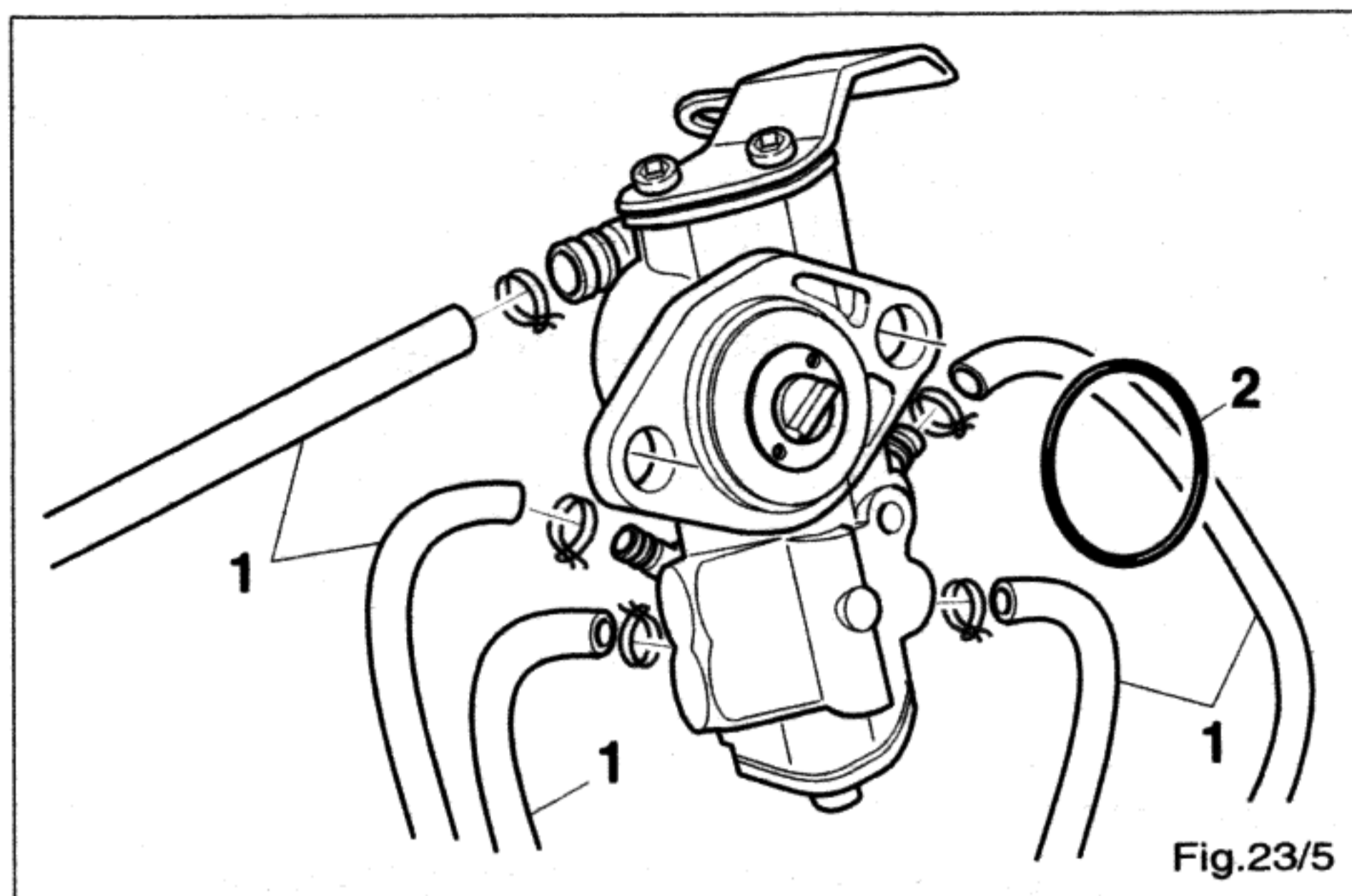
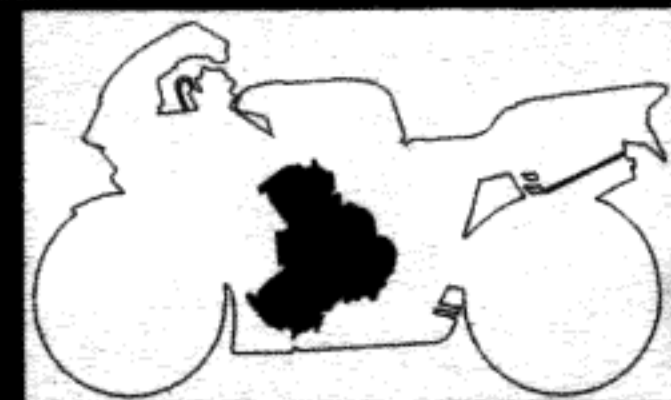

POMPA OLIO

1. Esaminare:
pompa olio
Movimento leva ruvido o perdite d'olio ⇒ Sostituire
2. Esaminare:
tubi olio "1"
Danneggiamento ⇒ Sostituire
O-Ring "2"
Danneggiamento ⇒ Sostituire

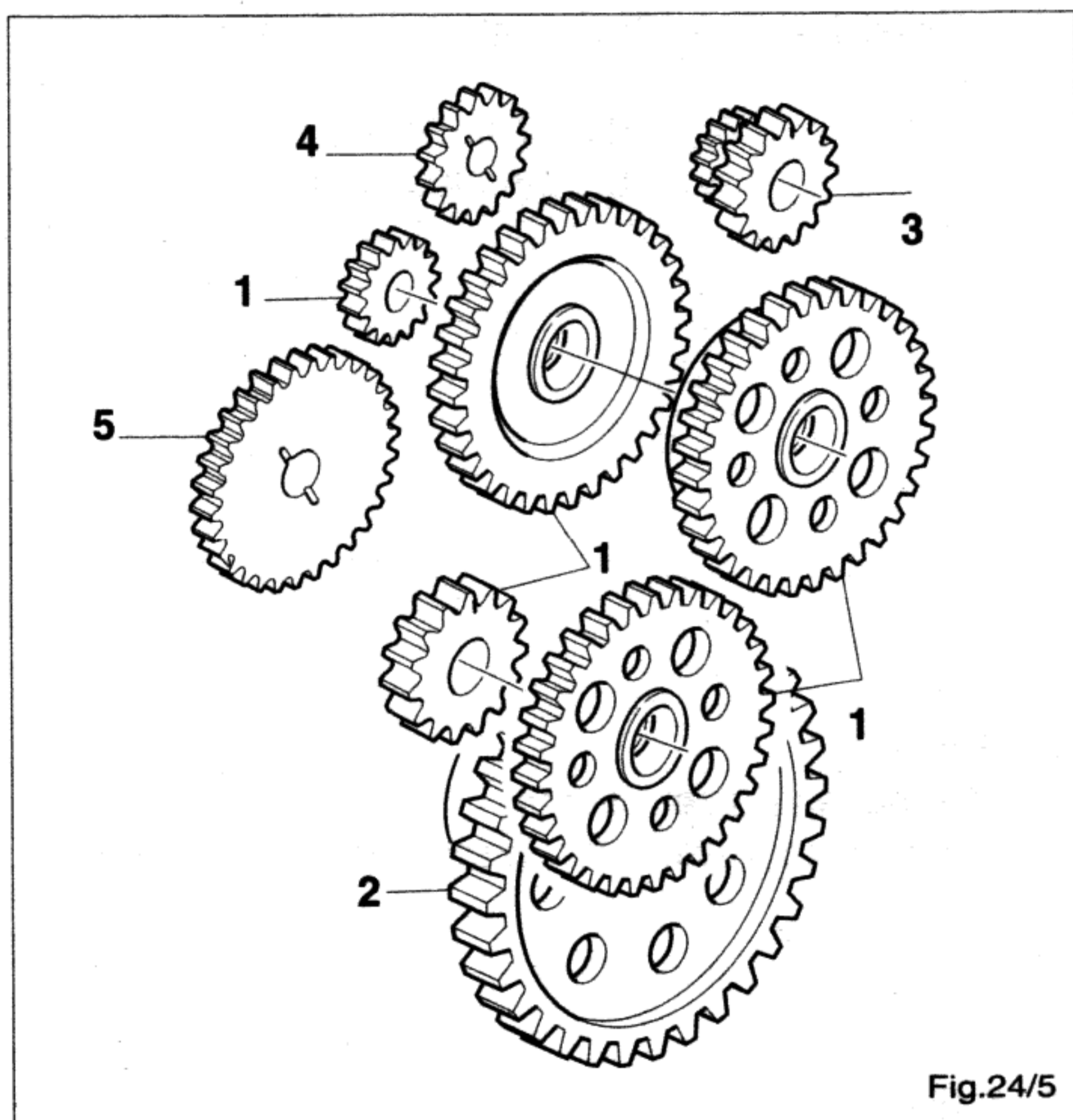

INGRANAGGI PRIMARI

1. Esaminare:
ingranaggi alberi motore "1"
Danneggiamenti o usura ⇒ Sostituire
2. Esaminare:
ingranaggio frizione "2"
Danneggiamenti o usura ⇒ Sostituire
3. Esaminare:
ingranaggio intermedio "3"
Danneggiamenti o usura ⇒ Sostituire
4. Esaminare:
ingranaggi pompa acqua "4" e olio "5"
Danneggiamenti o usura ⇒ Sostituire

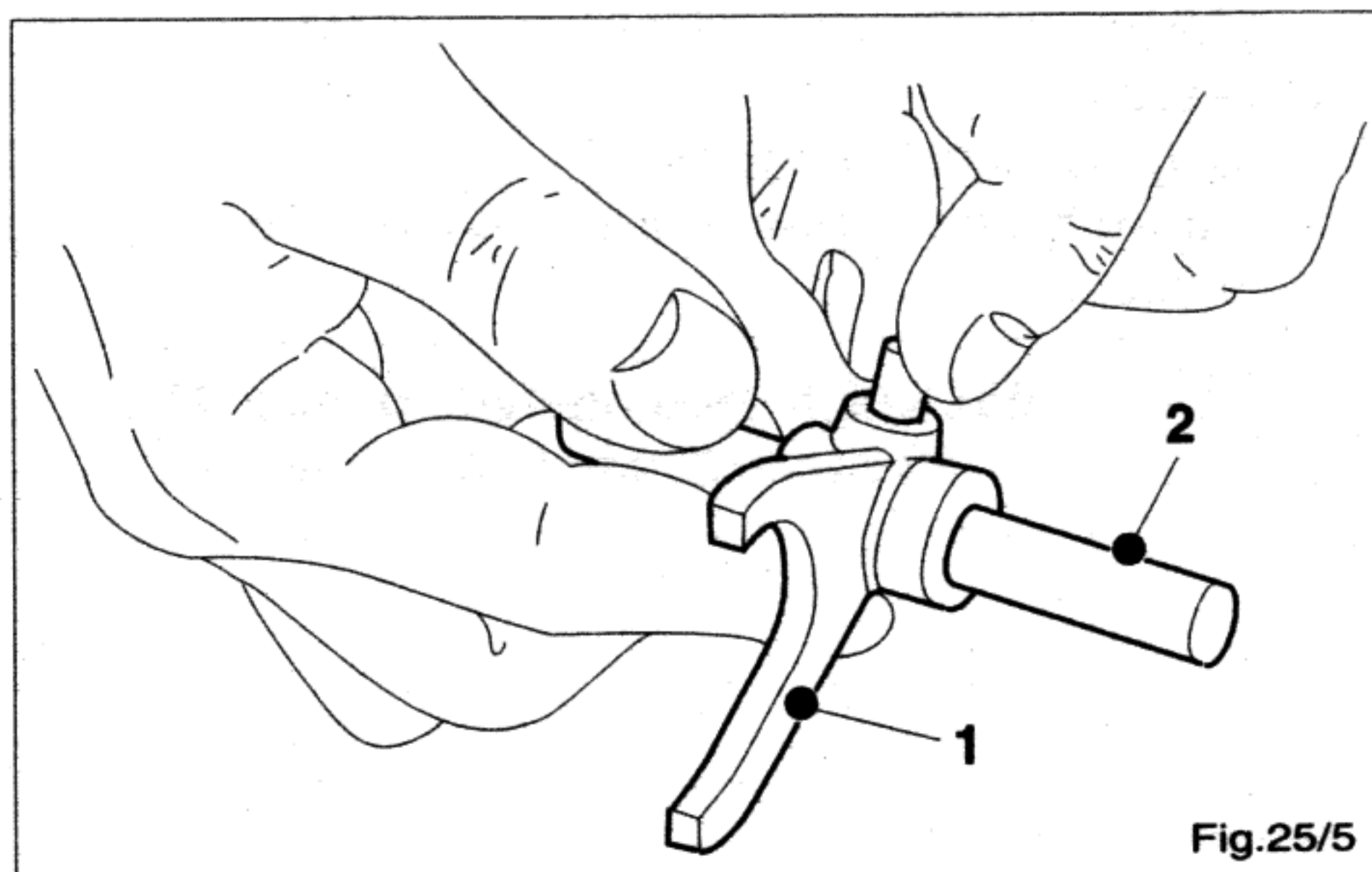

TRASMISSIONE

1. Esaminare:
forchette selettore "1" (sulla superficie di contatto con gli ingranaggi e con il desmo).
Usura, scalfitture, centraggio o rotture ⇒ Sostituire
2. Controllare:
movimento forchetta (montata sui perni-guida "2")
impedimenti ⇒ Sostituire forchetta selettore
⇒ Sostituire perni-guida

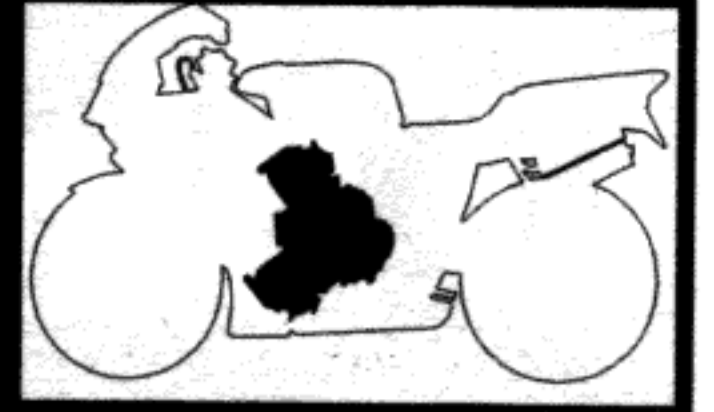

OIL PUMP

1. Inspect:
Oil pump
Unsmooth lever operation or oil leaks ⇒ Replace.
2. Inspect:
Oil pipes "1"
Contamination ⇒ Clean.
O-rings "2"
Wear, cracks or damage ⇒ Replace.

ÖLPUMPE

1. Prüfen:
Ölpumpe
Ungleichmäßige Bewegung des Hebels oder Ölaustritt ⇒ Erneuern.
2. Prüfen:
Ölrohre "1"
Verschmutzung ⇒ Reinigen.
O-Ringen "2"
Abnutzung, Risse oder Beschädigung ⇒ Erneuern.

PRIMARY GEAR

1. Inspect::
Gears "1" (crankshaft)
Damage or wear ⇒ Replace.
2. Inspect::
Gears "1" (clutch)
Damage or wear ⇒ Replace.
3. Inspect::
Gears "1" (kick idle)
Damage or wear ⇒ Replace.
4. Inspect::
Gears "1" (water and oil pump)
Damage or wear ⇒ Replace.

PRIMÄZÄHRÄDER

1. Prüfen:
Zahnräder "1" (Kurbelwelle)
Beschädigung oder Abnutzung ⇒ Erneuern.
2. Prüfen:
Zahnräder "1" (Kupplung)
Beschädigung oder Abnutzung ⇒ Erneuern.
3. Prüfen:
Zahnräder "1" (Kickstarter)
Beschädigung oder Abnutzung ⇒ Erneuern.
4. Prüfen:
Zahnräder "1" (Ölpumpen und Wasserpumpe)
Beschädigung oder Abnutzung ⇒ Erneuern.

TRANSMISSION

1. Inspect::
Shift forks "1" (on the gear and shift cam contact surfaces)
Wear, chafing, bends or damage ⇒ Replace.
2. Check:
Shift fork movement (on its guide bar "2")
Unsmooth operation ⇒ Replace fork
⇒ Replace guide bar.

GETRIEBE

1. Prüfen:
Schaltgabel "1" (Kontaktflächen mit Zahnrädern und Schaltwalze)
Abnutzung, Biegung, Beschädigung ⇒ Erneuern.
2. Prüfen:
Bewegung der Schaltgabel (auf der Führungsstange)
Ungleichmäßige Bewegung ⇒ Schaltgabel erneuern
⇒ Führungsstange erneuern.

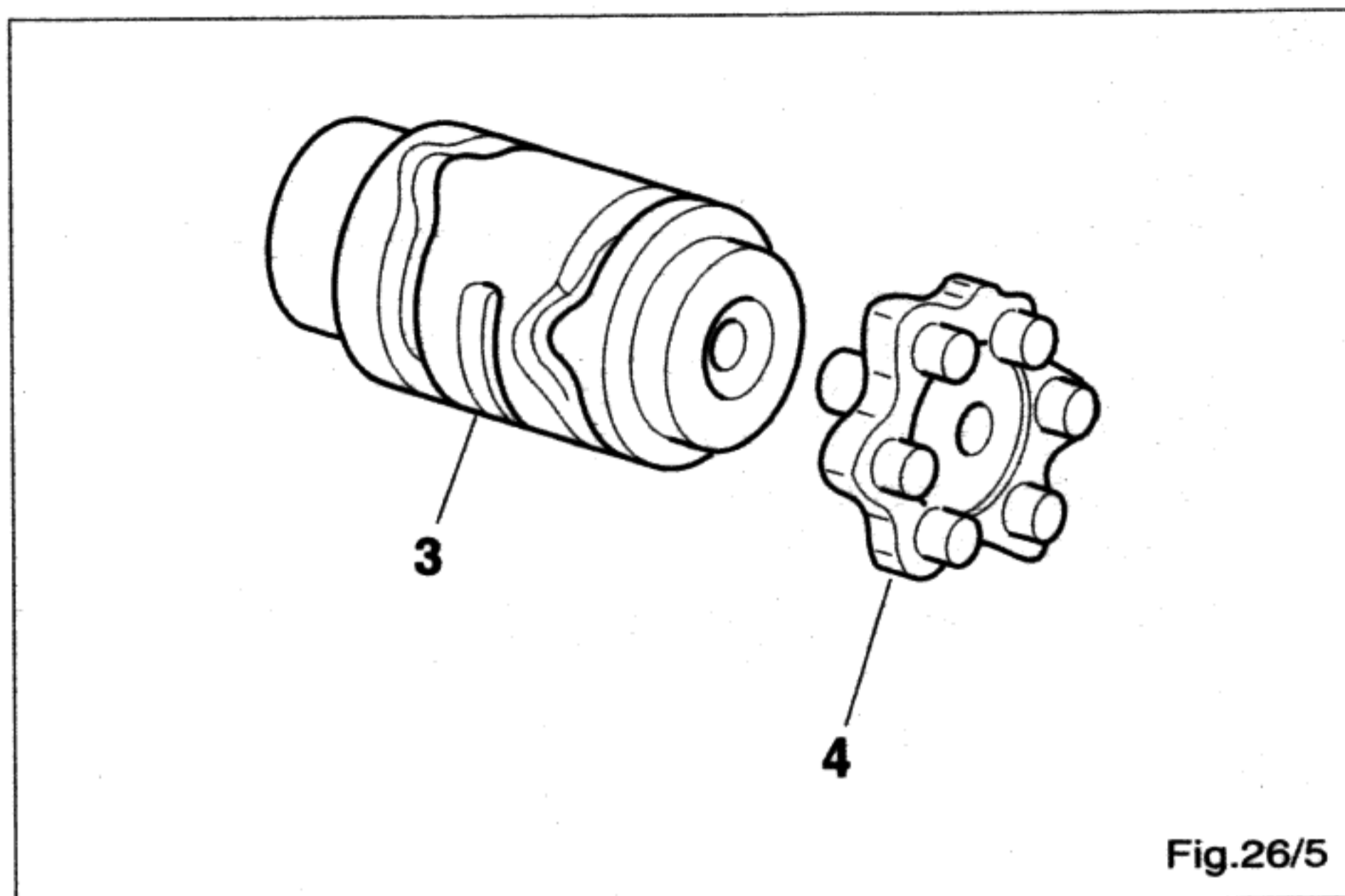
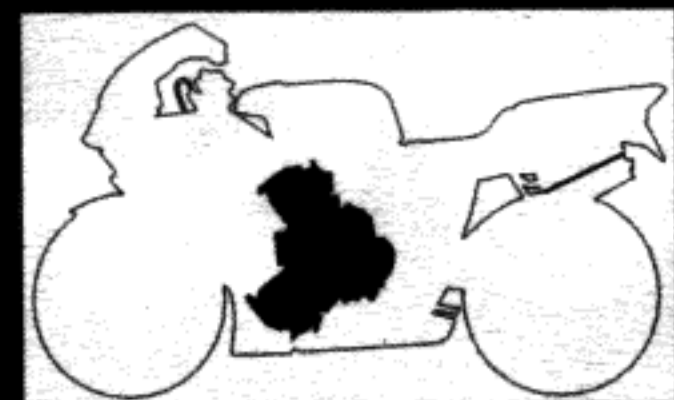

3. Esaminare:
desmo "3"
Usura, scalfitture o danneggiamento ⇒ Sostituire
selettore a stella "4"
danneggiamento ⇒ Sostituire

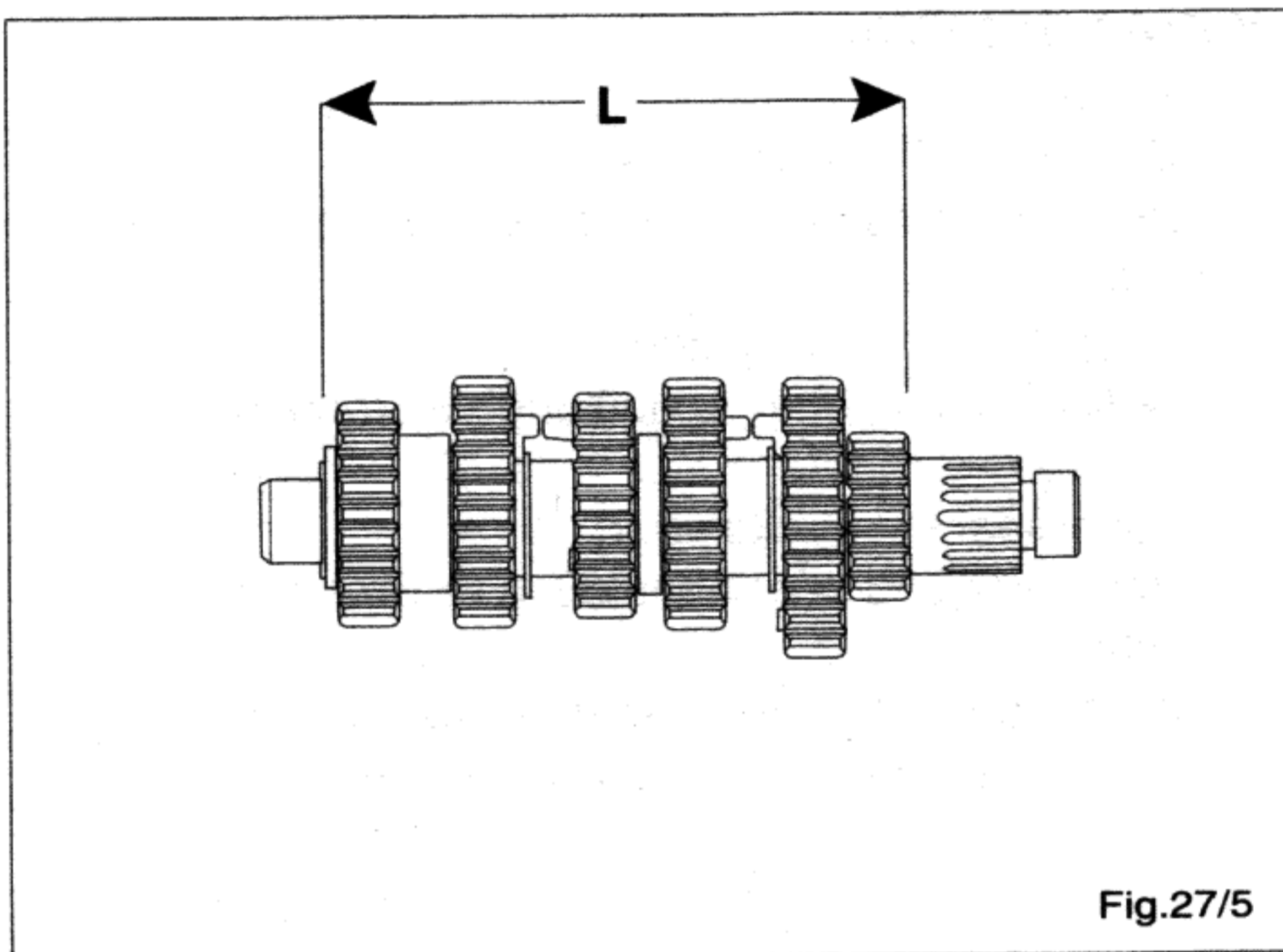

4. Esaminare:
O-Ring (albero secondario)
Usura o danneggiamento ⇒ Sostituire
ingranaggi
Usura o danneggiamento ⇒ Sostituire
scanalature
Rotture, usura o danneggiamento ⇒ Sostituire
5. Controllare:
movimento ingranaggi
impedimenti ⇒ Sostituire
6. Misurare:
lunghezza albero primario assemblato



**Lunghezza albero primario completo "L":
119,2 mm. (4,69 in)**

7. Lubrificare:
albero primario
albero secondario

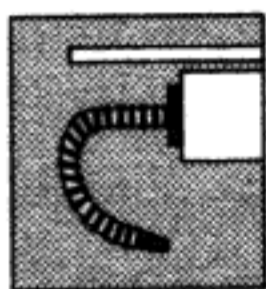

Grasso al bisolfuo di molibdeno

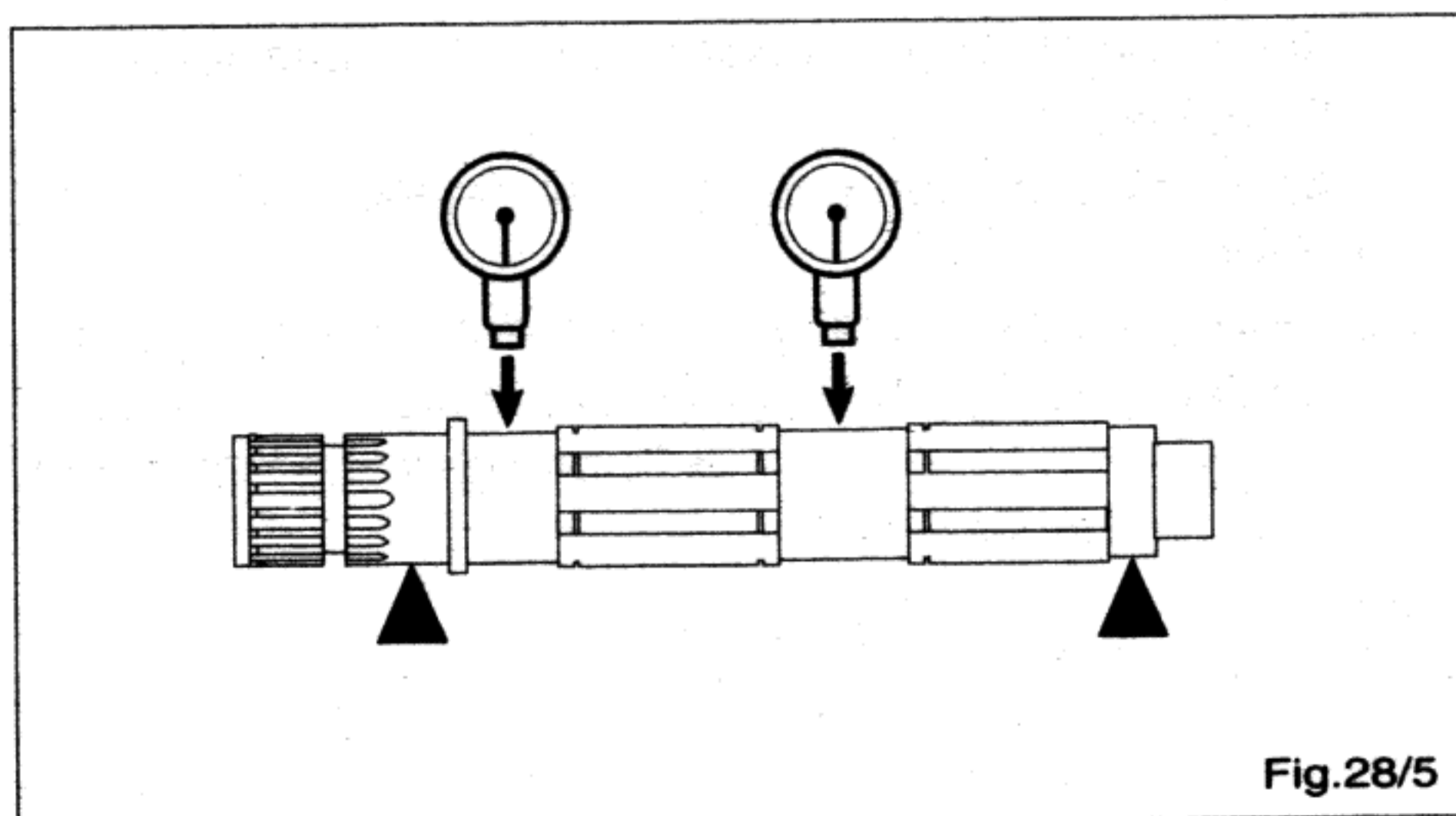

8. Misurare:
centraggio alberi trasmissione (usare comparatore)
Fuori dalle specifiche ⇒ Sostituire



**Limite centraggio :
0,03 mm. (0,0012 in)**

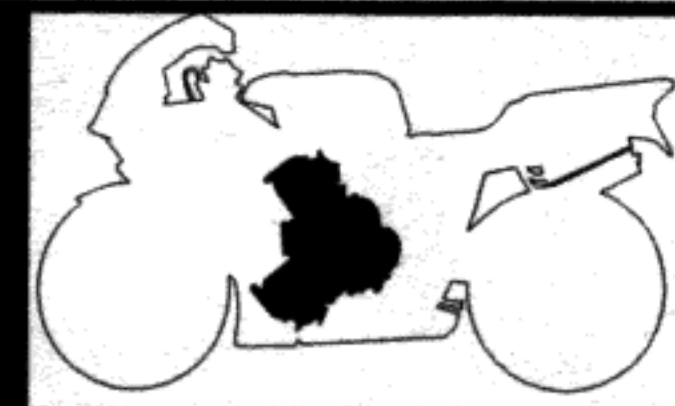

3. Inspect:

- Shift cam grooves "3"
- Wear, damage or scratches ⇒ Replace.
- Shift cam segment "4"
- Damage or wear ⇒ Replace.

3. Prüfen:

- Schaltwalzennuten "3"
- Abnutzung, Beschädigung oder Kratzer ⇒ Erneuern.
- Schalwalzensegment "4"
- Beschädigung oder Abnutzung ⇒ Erneuern.

4. Inspect:

- O-ring (Main axle)
 - Wear or damage ⇒ Replace.
 - Gears
 - Wear or damage ⇒ Replace.
 - Mating dogs
 - Cracks, wear or damage ⇒ Replace.
5. Check:
- Gear movement
 - Unsmooth operation ⇒ Replace.
6. Measure:
- Main axle (Assembled)

4. Prüfen:

- O-ringe (Getriebehaupt)
 - Abnutzung oder Beschädigung ⇒ Erneuern.
 - Zahnräder
 - Beschädigung/Abnutzung ⇒ Erneuern.
 - Schalbklaunen
 - Risse, Beschädigung oder Abnutzung ⇒ Erneuern.
5. Kontrollieren:
- Bewegung der Zahnräder
 - Ungleichmäßige Bewegung ⇒ Erneuern.
6. Messen:
- Hauptwelle (Montiert)



Main Axle Length: "L":
119.2 mm. (4,69 in)



Hauptwellenlänge: "L":
119.2 mm. (4,69 in)

7. Lubricate:

- Main axle
- Drive axle

7. Schmieren:

- Hauptwelle
- Antriebswelle

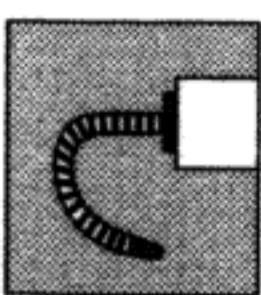

Molybdenum Disulfide Oil

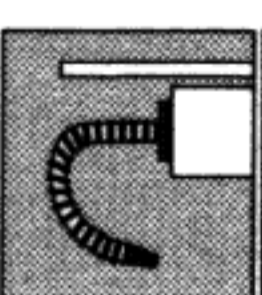

Molybdändisulfid-Öl

8. Measure:

- Axle runout (Use Dial Gauge)
- Out of specification ⇒ Replace.

8. Messen:

- Wellenschlag (Meßuhr verwenden).
- Abweichung von Spezifikation ⇒ Erneuern.



Runout Limit:
0.03 mm. (0.0012 in)



Max. Zul. Wellenschlag:
0.03 mm. (0.0012 in)

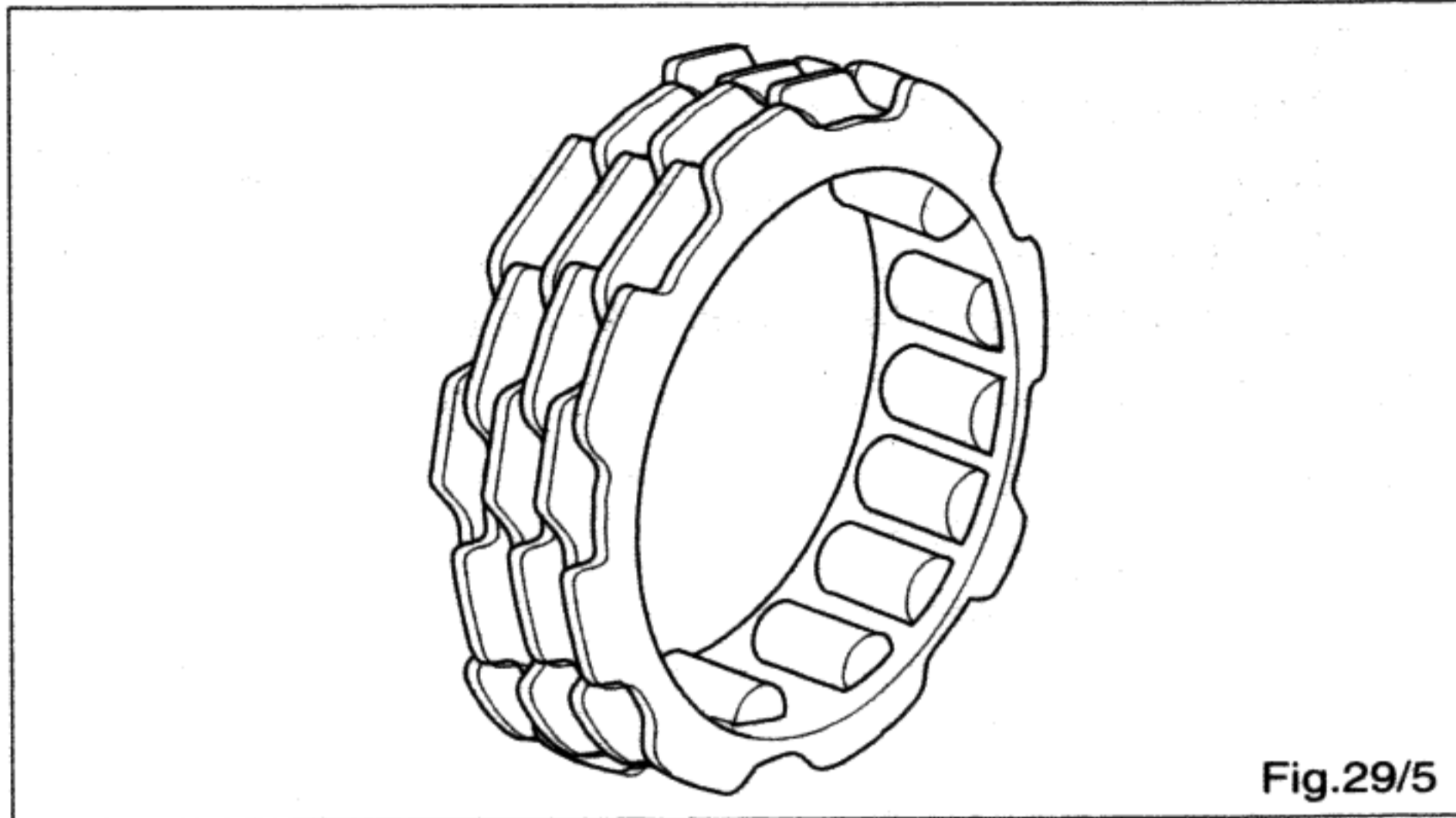
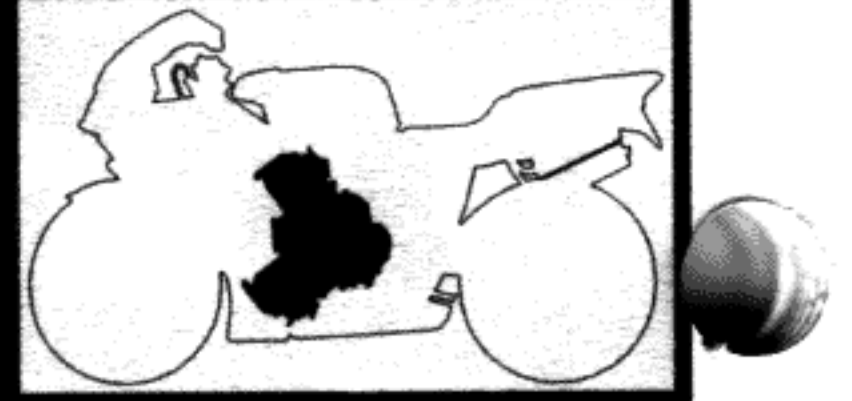

Fig.29/5

RUOTA LIBERA

1. Esaminare:
ruota libera
Usura o danneggiamento ⇒ Sostituire

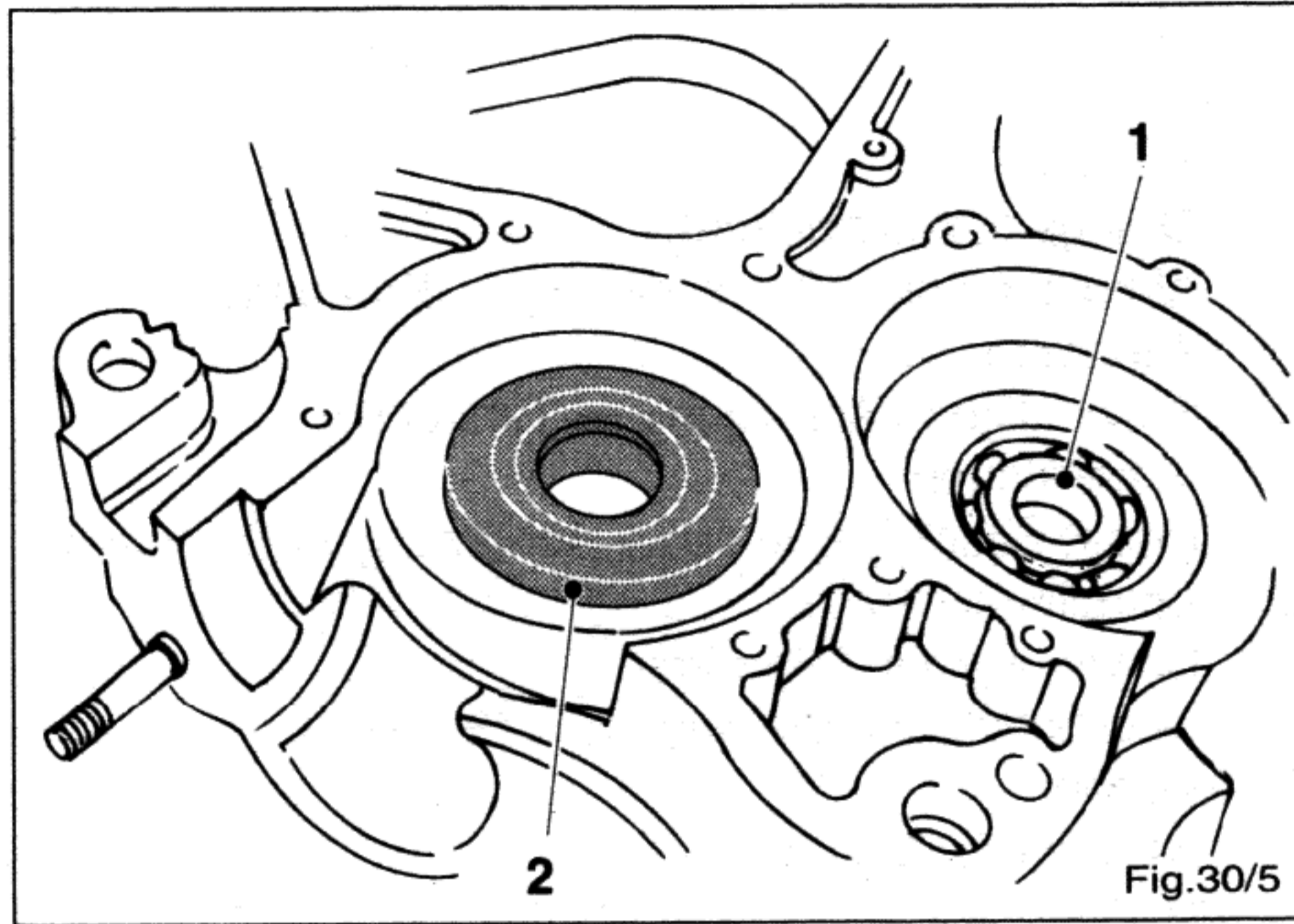

Fig.30/5

CUSCINETTI E PARAOLI

1. Esaminare:
rotolamento anello interno "1" dei cuscinetti
paraoli
Usura o danneggiamento ⇒ Sostituire

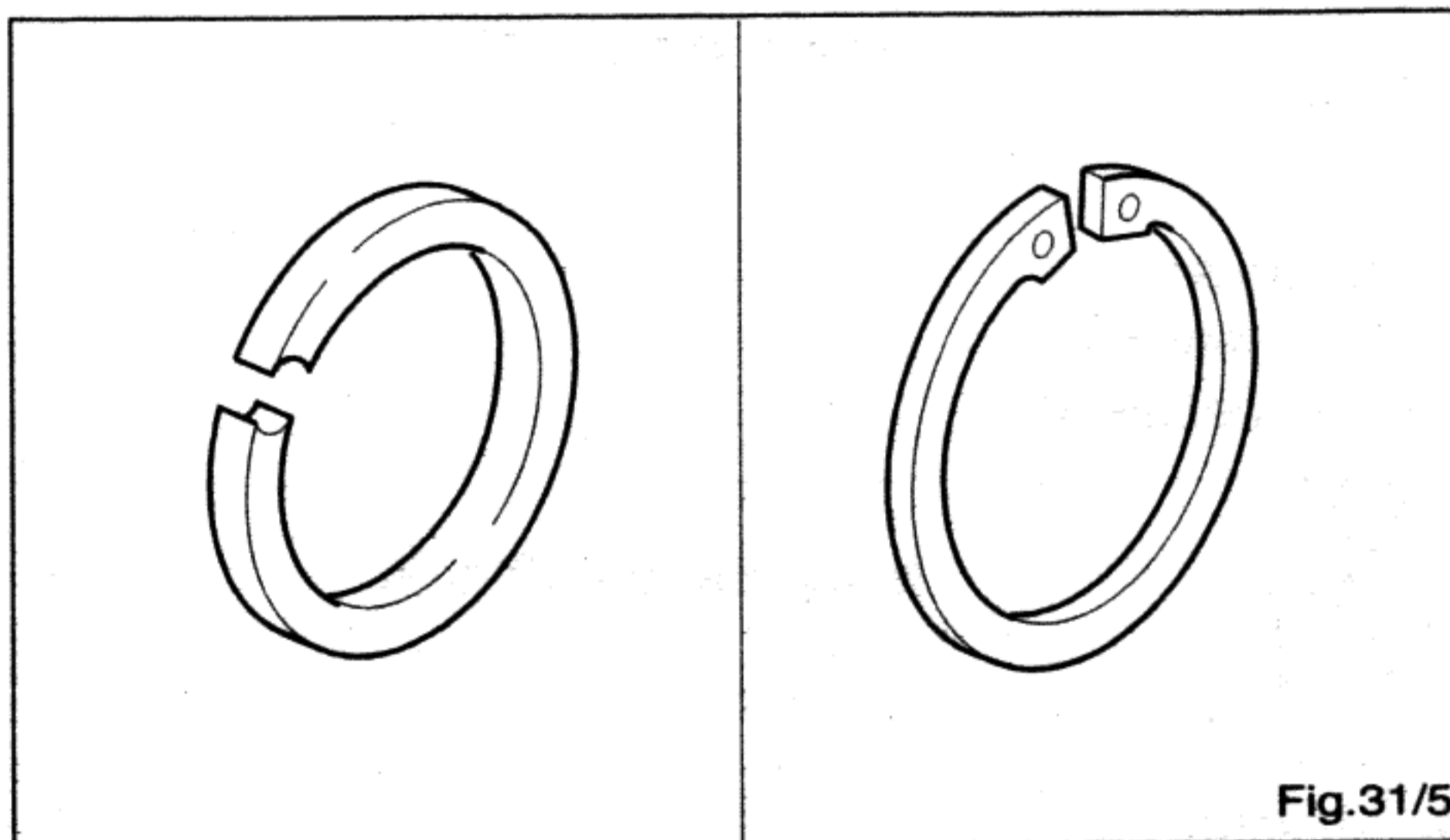
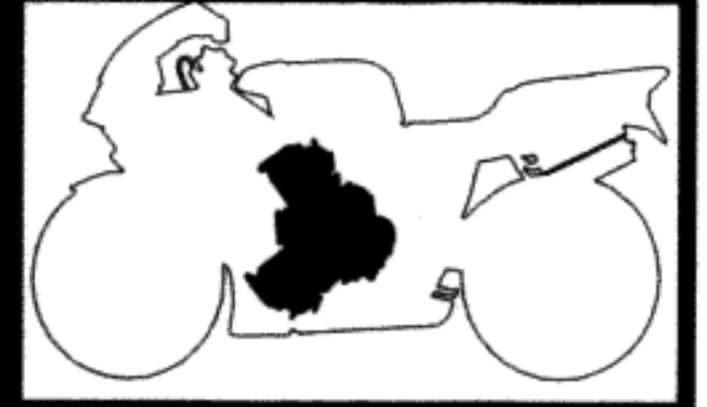

Fig.31/5

SEEGER E ANELLI ELASTICI

1. Esaminare:
seeger
anelli elastici
Danneggiamento, gioco o deformazione ⇒ Sostituire

**FREE-WHEEL**

1. Inspect:
free-wheel
Wear or damage ⇒ Replace.

FREILAUF

1. Prüfen:
freilauf
Grübchenbinldung oder Beschädigung ⇒ Erneuern.

BEARING AND OIL SEAL

1. Inspect:
Axle bearings "1"
oil seal
Wear or damage ⇒ Replace.

LAGER UND DICHRINGEN

1. Prüfen:
Achslager
Dichtringen
Grübchenbinldung oder Beschädigung ⇒ Erneuern.

CIRCLIP AND WASHER

1. Inspect:
Circlips
Washers
Damage, looseness or bends ⇒ Replace.

SPRENGRINGE UND SCHEIBEN

1. Prüfen:
Sprengringe
Scheiben
Beschädigung, Lockerung oder Biegung
⇒ Erneuern.