

ENG

USERMANUAL



INTRODUCTION

Thanks for your purchasing of this vehicle. This model is designed for safety, built for durability, and perfected for daily street use. The unique vehicle design, enrich of stylish and peronality, represents your outstanding taste and favor to pursue the state of the art living attitude.

This manual describes the correct usage of this motorcycle including safety riding, simple inspection methods and so on. For a more comfortable and safety riding, please read this manual carefully. If any questions concerning the operation or maintenance of your vehicle, please consult a dealer.

IMPORTANT MANUAL INFORMATION

In this manual with some important information is distinguished by the following notations:

WARNING

It is **WARNING** instructions that need to follow, failure of follow could be end in result severe injury or lead to death to the operator.

CAUTION

A **CAUTION** indicates with special precautions to avoid damage to the vehicle.
A **CAUTION** indicates important information in this manual.

CAUTION

- Please always put this manual with vehicle for rider maintenance/ dealer tracking of service records even if vehicle is being sold.
- This manual contains the most of the vehicle information, however, the maker will continually improve it's product design and quality that lead to difference between the manual and vehicle . If you have any questions concerning this manual, please consult your dealer.

WARNING

FOR YOUR OWN SAFETY, PLEASE READ THIS MANUAL CAREFULLY BEFORE OPERATION THIS VEHICLE. ONLY OPERATE THE VEHICLE UNTIL YOU HAVE COMPLETELY AWARE OF ADEQUATE KNOWLEDGE OF CONTROLS AND OPERATION FEATURE AND YOU HAVE BEEN TRAINED IN SAFE AND PROPER RIDING TECHNIQUES. PERIODIC INSPECTIONS, WELL MAINTENANCE AND GOOD RIDING SKILLS, WILL ENSURE YOUR SAFETY RIDING AND INCREASE THE PRODUCT RELIABILITY OF THIS VEHICLE.

*Product and specifications are subject to change without notice.

IMPORTANT MANUAL INFORMATION



TABLE OF CONTENTS

INTRODUCTION	1	Side and main stand.....	18	Tires.....	29
IMPORTANT MANUAL INFORMATION	2	Seat.....	18	<i>Tire air pressure</i>	29
TABLE OF CONTENTS	4	<i>Disassembly of the seat</i>	18	<i>Tire inspection</i>	29
SAFETY INFORMATION	6	<i>Disassembly of the seat (BX 125 R only)</i>	19	Rims.....	30
<i>Safe riding</i>	6	Combined brake system (CBS).....	19	Brakes.....	30
<i>Protective clothing</i>	6	PRE-OPERATION CHECKS	20	<i>Brake free play</i>	30
<i>Modifications</i>	7	Pre-operation check list.....	21	Brake pads.....	31
<i>Loading and accessories</i>	7	OPERATION AND IMPORTANT RIDING POINTS	22	<i>Brake pads</i>	31
<i>Accessories</i>	7	Starting the engine.....	22	Brake fluid.....	31
<i>Gasoline and exhaust gas</i>	8	Starting off.....	22	<i>Changing the brake fluid</i>	32
Other safe-riding points.....	8	Shifting and riding.....	22	Cables.....	32
DESCRIPTION OF THE VEHICLE	9	Acceleration / Deceleration.....	23	Throttle grip and cable.....	32
Components (All variants).....	9	Braking.....	23	Lubricating the brake lever and brake pedal.....	32
Components (BX125 X only).....	11	Stop the Engine / Parking.....	23	Side stand / Main stand.....	32
Components (BX125 R only).....	11	Engine break in.....	23	Front fork.....	32
Components (BX125 H only).....	12	PERIODIC MAINTENANCE AND MINOR REPAIR	25	Steering.....	33
CONSUMER INFORMATION	13	<i>Check the spark plug</i>	25	Wheel bearings.....	33
Vehicle identification number (VIN).....	13	Engine oil.....	26	Drive chain.....	34
INSTRUMENT AND CONTROL FUNCTIONS	14	<i>Check engine oil</i>	26	<i>Tensioning the chain drive</i>	34
Instruments.....	14	<i>Oil change</i>	27	Battery.....	34
Power lock.....	14	Fuel filter.....	27	<i>Charge the battery</i>	34
Steering Lock.....	15	ECU (Engine Control Unit).....	27	<i>Store the battery</i>	35
Left handlebar.....	15	Throttle cable free play.....	28	Fuse.....	35
Right handlebar.....	16	<i>Throttle cable free play adjustment</i>	28	<i>Replacing the fuse</i>	35
Fuel tank.....	16	Clutch free play.....	28	Lighting.....	35
Gearshift pedal lever.....	17	<i>Clutch free play adjustment</i>	28	<i>Headlight</i>	35
Rear brake pedal.....	18			<i>Turn signal, Tail and Brake light</i>	35
				<i>License plate light</i>	35
				TROUBLESHOOTING	36

TABLE OF CONTENTS

Troubleshooting chart.....	36
CLEAN AND STORAGE.....	38
Clean the vehicle.....	38
<i>Before cleaning</i>	38
<i>Cleaning after normal use</i>	38
<i>Cleaning after riding in the rain, near the sea or on salt-sprayed roads</i>	38
<i>After cleaning</i>	39
Storage.....	39
<i>Short-term (for a few days)</i>	39
<i>Long-term (for weeks)</i>	39
WARRANTY INFORMATION.....	43
SERVICE AND MAINTENANCE.....	44
Important information.....	44
Maintenance schedule.....	45
Service record.....	46
SPACE FOR NOTES.....	47

SAFETY INFORMATION

THIS VEHICLE ARE TWO WHEEL SINGLE TRACK VEHICLES. THE USE OF SAVETY AND OPERATI-ON MAY IN DIFFERENT RESULT BY THE USE OF PROPER RIDING TECHNIQUES OF THE OPERATOR. TO REMIND OF OPERATOR, WHO SHOULD KNOW THE FOLLOWING REQUIREMENTS BEFORE RIDING.

HE OR SHE SHOULD:

- WELL TRAINED AND FIMILIAR TO ALL THE ASPECTS OF Vehicle OPERATION.
- FULLY READ AND AWARE OF MAINTENANCE REQUIREMENTS THAT NOTED IN THIS OWNER'S MANUAL.
- OBTAIN QUALIFIED TRAINING & LEGAL LICENSE FOR OPERATI-ON OF THIS VEHICLE.
- WELL AND PROFESSIONAL MAINTENANCE SERVICE FOR OPERATOR AND CERTIFICA-TED REPAIR SHOP/DEALER TO ACQUIRE GOOD MECHANICAL CONDITIONS OF VEHICLE.

Safe riding

- Always pre-check your vehicle befo-re riding is key point to prevent an accident.
- Please follow the maxium loads limi-ted of operator and passenger.
- Most of accident on the motorists is cased by automobile driver who "fai-lure to recognize out the vehicle" and caused mobile/vehicle accidents. Therefore, to make yourself conspi-cuous apprear to public will be very effective in reducing the change of this kind of accidents.

Therefore:

- Wear a brightly colored and protecti-ve clothes/Jacket
- Operate the turning signals before turning and slow down the Speed when approaching and passthrough the intersection
- Keep proper distance with other Mo-torists, and let them aware of your location
- Know your skills and limits

- Never lend your vehicle to oththers who not qualified for riding
- Always follow the legal speed limit on the vehicle and traffic law
- The posture of the operator and passenger is important for proper control. properly riding posture can Keep vehicle in balance while riding.
 - Operator should sit up-right with two hand hold on handle bar, foot on floorboard while driving.
 - Passenger should make sure that he/she can firmly hold on grip or operator with foot step on footrest.
- Drving after Acohol drink or other il-legal drugs is strickly prohibited.
- This vehicle is designed for onroad use only. It is not suitable for off-road use.

Protective clothing

Properly clothing yourself will keep you safety from potential accidents:

- Always wear an approved helmet.
- With face shield to protect your eye from dust and rain drop.

SAFETY INFORMATION

- The wear of proper jacket, shoes, groves etc., can be better protection, reducing the degree of injury from un-expected accident.
- Never wear loose-fitting clothes, otherwise they could catch on the control levers or wheels and cause injury or an accident.
- Never touch the engine or exhaust system during or after operation. They become very hot and can cause burns. Always wear protective clothing that covers your legs, ankles, and feet.

Modifications

Modifications made to this vehicle that not approved by maker, or the removal of original equipment, may let vehicle unsafe for use and cause severe personal injury. Modifications may also make your vehicle illegal touse.

Loading and accessories

Adding accessories or cargo to your vehicle may cause the different on the weight distribution of vehicle and in-

fluence on the steering & balance. It may cause possibility of an accident, please extremely caution and follow below limitation when you equipped with accessories. Below are some general or accessories. Here are some guidelines to follow if loading cargo or adding accessories to your vehicle.

Loading

The total weight of the operator, passenger (when allowed), accessories and cargo must not exceed the maximum load limit.

Maximum load
(not include the vehicle):
150kg

When loading within this weight limit, keep the following in mind:

- Cargo and accessory weight should be kept as low and close to the vehicle as possible. Make sure to distribute the weight as evenly as possible on both sides of the vehicle to

minimize imbalance or instability.

- Make sure that accessories and cargo are securely attached to vehicle before riding
- Never attach any large or heavy items to the handlebar, front fork, or front fender. Such items can create unstable handling or a slow steering response.

Accessories

Genuine accessories have been specifically designed for use on this vehicle. If need, please contact with dealer for detail. Since the maker can not test all other accessories , you must personally be responsible for the proper selection, installation and use of non-OEM accessories.

Keep the following guidelines in mind, when mounting accessories.

- Never install accessories or carry cargo that would influence on the ground clearance, limit suspension travel, steering, or obscure lights or turning lights, reflectors.

SAFETY INFORMATION

- Accessories on the handle bar/front suspension area will cause bad influence on steering the vehicle. If you will install accessories, please keep it as light in weight and not interfere on steering the vehicle. This vehicle is for On-Road transportation purpose only, please do not install any of extended cargo carrier as sully, that will make vehicle unstable in cross winds and vehicle turns.
- While equip with electrical accessories, please consult with qualified stores, to make sure such items will not exceed the capacity of the vehicle's electrical system. Unproper install of such items may cause a dangerous loss of lights, lower engine power or even damage the vehicle.
- Take care not to spill any gasoline on the engine (hot) or exhaust system when refueling.
- Do not smoke or use Mobile phone while re-fueling.
- Never start the engine or let it run for any length of time in a closed area. The exhaust fumes are poisonous and may cause loss of consciousness and death within a short time.
- Always turn the engine off before leaving the vehicle and remove the key from the main switch. When parking the vehicle, please note the following:
 - The engine and exhaust system remain hot, therefore, park the vehicle in a place where pedestrians or children are not likely to touch these hot areas.
 - Do not park the vehicle on a slope or soft ground, otherwise it may fall over.
 - Do not lay your vehicle to near flammable place.
- In case of swallow any gasoline, or gasoline get into your eyes, please see your doctor immediately. Keep away the gasoline to your skin and water.

OTHER SAFE-RIDING POINTS

- Turn the signal before making turns.
- When raining or across on run on the wet road, Iron Plates, keep your speed low, slightly using braking to avoid slipping or even fall down.
- Be careful when passing parked cars. A driver might not see you and open a door in your path.

Gasoline and exhaust gas

- GASOLINE IS HIGHLY FLAMMABLE:
 - Always turn the engine off when refueling.

DESCRIPTION OF THE VEHICLE

COMPONENTS (ALL VARIANTS)

1. Clutch lever
2. Left handlebar switches
3. Power lock
4. Instrument
5. Right handlebar switches
6. Throttle grip
7. Front brake lever

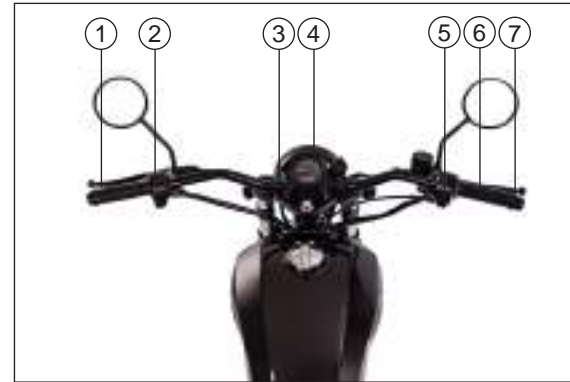

8. Front wheel
9. Front brake caliper
10. Front turn signal light
11. Clutch shift pedal
12. Air filter element
13. Battery
14. Foot pedal
15. Rear wheel
16. Rear turn signal light
17. Tail light



DESCRIPTION OF THE VEHICLE

- 18. Muffler
- 19. Rear brake
- 20. Seat
- 21. Main stand
- 22. Front foot pedal
- 23. Fuel tank
- 24. Fuel tank cap
- 25. Rear-view mirror
- 26. Headlight
- 27. Reflector assembly
- 28. Front fender
- 29. Front brake disc



DESCRIPTION OF THE VEHICLE

COMPONENTS (BX125 X ONLY)

30. Windshield



COMPONENTS (BX125 R ONLY)

31. Seat cover

32. Rear view mirror



DESCRIPTION OF THE VEHICLE

COMPONENTS (BX125 H ONLY)

33. Windshield



CONSUMER INFORMATION

VEHICLE IDENTIFICATION NUMBER (VIN)

Please write down the VIN (vehicle identification number) to order replacement parts from your dealer or the vehicle should be stolen.

The vehicle identification number of the vehicle (1) is stamped on the steering head, the anti-tampering label (2) is located on the left hand side.

CAUTION

The vehicle identification number is used to identify your motorcycle and may be used to register your vehicle with the licensing authority in your area.

The engine number (3) is engraved on the left of the motor housing.



INSTRUMENT AND CONTROL FUNCTIONS

INSTRUMENTS

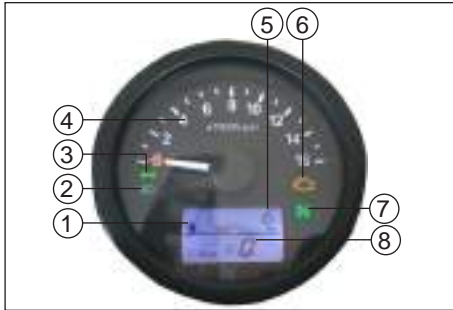

1. Fuel indicator

It indicates the fuel volume in the fuel tank. It will point to 5 when the fuel tank is full; and it will point to 1 or below when the fuel is inadequate, and it will flash.

2. High beam indicator

When the headlight high beam indicator turns on, the high beam indicator is on.

3. Turn signal light indicator

When the left or right turn signal light is on, the corresponding left or right turn

signal indicator will flash.

4. Speedometer

The Speedometer shows the engine revolutions from 0-16×1000rpm.

5. Odometer

Total mileage (ODO) records the total distance ran in the range of 0-99999 km; when exceeding 99999 km, it still shows 99999 Km.

6. European On-Board Diagnostics (EOBD)

When powering on but not starting the engine under normal circumstances, EOBD indicator will be illuminated, and automatically go off several seconds after starting the engine. If it does not go off and flashes, the vehicles may have some faults and need to repair. Please contact the local dealer to check the faults with the special fault diagnostic instrument of motorcycle.

7. Neutral gear lamp

When the transmission is in the neutral position, the neutral pilot lamp will be illuminated.

8. Speedometer

Speedometer indicates the riding speed of vehicles. You can choose the units (mph or km/h) by continuously switching power door twice according to your needs, and the display range is 0-199km/h or 0-124mph.

POWER LOCK



Rotating the key clockwise, the power

INSTRUMENT AND CONTROL FUNCTIONS

will turn on; the engine can be started; and the key cannot be removed; rotating the key counterclockwise, the power is turned off; the engine cannot be started; and the key can be taken out.

STEERING LOCK



Put the key in the steering lock located on the bottom right side of the steering. Rotate the handlebar to the left and turn the key counterclockwise to the red dot, the steering lock will be activated. The key can be taken out.

LEFT HANDLEBAR

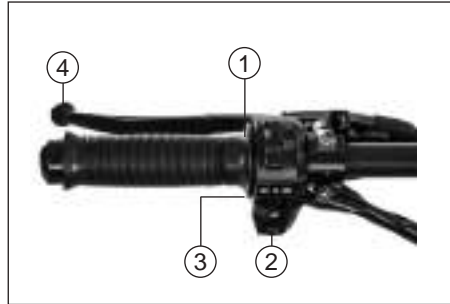

9. Switch of headlight high beam and low beam

When the switch of headlight high beam and low beam is at “

10. Horn button

Pressing the horn button, the horn will sound.

11. Turn signal light switch

Pressing the left turn signal light switch (3), the left turn signal light will be on and flash. At the same time, the green turn light indicator on the instrument panel will flash; pressing the right turn signal light switch (3), the right turn signal light will be on and flash. At the same time, the green turn light indicator on the instrument panel will flash. If releasing the turn signal lights, you need to switch the turn signal lights to the middle.

12. Clutch

When starting the engine or shifting, operate the clutch lever to cut off the riding of the rear wheel.

INSTRUMENT AND CONTROL FUNCTIONS

⚠ WARNING

When changing lanes or turning, turn on the turn signal lights in time. After turning, turn off the turn signal lights, so no one will be irritated.

RIGHT HANDLEBAR

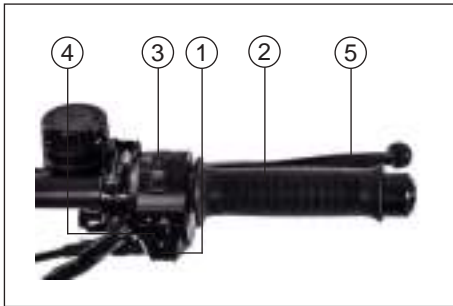

1. Electric starting button

Pressing the electric starting button, the electric motor will run, and the engine will be started.

2. Throttle grip

The throttle grip is used to control the engine speed. To increase the speed, turn the throttle grip towards yourself. To reduce the speed, turn the throttle grip in opposite direction.

3. Headlight switch

At „

4. Emergency light switch

When pressing „

5. Front brake lever

At front braking, slowly clench the handlebar on the right handle.

FUEL TANK



Remove the lock pressing the plate of the fuel tank, and open the tank by rotating the key of the cap (1) clockwise. To close the fuel tank cap, align the guide pin of the cap, then press the key downwards and return the key. Finally, cover the lock.

INSTRUMENT AND CONTROL FUNCTIONS

⚠ WARNING

- The fuel tank should not be filled excessively, and the fuel level should not exceed the edge of lower fuel tank port. The fuel should not be spilled on the hot engine, because this could lead to abnormal running of the motorcycle, or even accidents.
- When refueling, switch off the engine and turn the ignition key Off.
- Do not forget to cover the fuel tank after refueling to prevent excessive evaporation of fuel into the atmosphere, resulting in waste of energy and pollution to the environment.
- Do not smoke when refueling.
- If spilled gasoline enters into the carbon canister and other parts, please go to the motorcycle selling agency as soon as possible to clean or replace the canister, otherwise, the activated carbon in the canister will be invalid

too early due to the excessive gasoline in the canister.

- Always check the smoothness of the lower port of fuel tank cap to ensure smooth drainage and to prevent external moisture from entering the tank chamber.

Regular unleaded gasoline only.

Recommended fuel:

Min. 95 oct

!!CAUTION!!

**BIOETHANOL E10 IS NOT
SUITABLE**

GEARSHIFT PEDAL LEVER



This vehicle is equipped with a 5-speed gearshift (non-cycle). Neutral is located between first and second gear.

If the gear is in neutral, push down the gearshift lever to shift into first gear. Pull the lever up for shifting into next gear. For shifting down push the lever down again. Shift only one gear at a time. More than one gears cannot be shifted, because of the shifting mechanism.

INSTRUMENT AND CONTROL FUNCTIONS

REAR BRAKE PEDAL



Push the rear brake lever down to engage the rear brake. When operating the rear brake, the brake light will turn on.

SIDE AND MAIN STAND

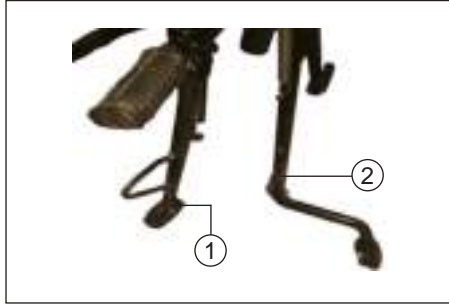

The side stand (1) is located on the left side of the vehicle. When parking, push down the side stand. The engine stop switch will be activated and the engine will shut down. Before starting the vehicle, push up the side stand. The engine can be started.

The main stand (2) is located at the bottom of vehicle. When parking, push down the main stand, and pull the vehicle backwards on the stand.

SEAT

Disassembly of the seat

1. Park the motorcycle on its main stand
2. Remove the seat bolt (1)
3. Take off the seat
4. Reassemble in reverse order



INSTRUMENT AND CONTROL FUNCTIONS

Disassembly of the seat (BX 125 R only)

1. Park the motorcycle on its main stand
2. Remove the seat cover bolt (2)
3. Remove the seat cover (3)
4. Remove the seat bolt (1)
5. Take off the seat
6. Reassemble in reverse order



COMBINED BRAKE SYSTEM (CBS)

The CBS (Combined Brake System) is a combined brake system which contributes to the road safety support of your motorcycle.

Your vehicle is equipped with a single CBS.

When the “foot brake” is pressed, this simultaneously activates both the front and rear brakes, therefore reducing the risk of one of the two wheels locking.

⚠ WARNING

Although both brakes are activated by the foot brake, the front brake still needs to be operated for a correct deceleration of the motorcycle.

PRE-OPERATION CHECKS

The condition of a vehicle is the owner's responsibility. The operator should check the vehicle by simple but thorough inspection, to make sure of vehicle condition, quick inspect some key and important parts, to prevent the vehicle from serious consequence/accident. Please carefully check the following points before each ride.

CAUTION

Pre-operation checks should be made each time the vehicle is used. Such an inspection can be accomplished in a very short time; and the added safety it assures is more than worth the time involved.

WARNING

**If any item in the Pre-operation check list is not working properly , have it inspected and repaired before operating the vehicle. If failed to be corrected by yourself, please turn to repair shop immediately.
If failed to be corrected by yourself, please turn to repair shop immediately.**

PRE-OPERATION CHECKS

PRE-OPERATION CHECK LIST

CHECKPOINT	TO VERIFY
Fuel	<ul style="list-style-type: none">• Check fuel level in fuel tank.• Refuel if necessary.• Check fuel line for leakage.
Engine oil	<ul style="list-style-type: none">• Check oil level in oil tank.• If necessary, add recommended oil to specified level.• Check vehicle for oil leakage.
Front brake	<ul style="list-style-type: none">• Check operation.• If soft or spongy, have dealer bleed hydraulic system.• Check brake pads for wear.• Replace if necessary.• Check fluid level in reservoir.• If necessary, add recommended brake fluid to specified level.• Check hydraulic system for leakage.
Rear brake	<ul style="list-style-type: none">• Check operation.• If soft or spongy, have dealer bleed hydraulic system.• Check brake pads for wear.• Replace if necessary.• Check fluid level in reservoir.• If necessary, add recommended brake fluid to specified level.• Check hydraulic system for leakage.
Throttle grip	<ul style="list-style-type: none">• Make sure that operation is smooth.• Check free play.• If necessary, have dealer adjust cable free play and lubricate cable and grip housing.
Wheels and tires	<ul style="list-style-type: none">• Check for damage.• Check tire condition and tread depth.• Check air pressure.
Brake levers	<ul style="list-style-type: none">• Make sure that operation is smooth. Lubricate lever pivoting points if necessary.
Main stand	<ul style="list-style-type: none">• Make sure that operation is smooth. Lubricate pivot if necessary.
Chassis fasteners	<ul style="list-style-type: none">• Make sure that all nuts, bolts and screws are properly tightened. Tighten if necessary.
Instruments, lights, signals and switches	<ul style="list-style-type: none">• Check operation, correct if necessary

OPERATION AND IMPORTANT RIDING POINTS



⚠ WARNING

- Before riding the vehicle, please make sure that you are fully familiar with all operating controls & their functions before riding. To consult a dealer shop if you not thoroughly understand.
- Please do not start the engine in a closed area, the exhaust air are poisonous, and inhaling them can cause loss of consciousness and even death in short time.

STARTING THE ENGINE

CAUTION

Note the point „Engine break in“ before you start to riding the vehicle.

1. Turn the key to ON .
2. Pull up the side stand.
3. Insert the neutral gear.
4. Actuate the front or the rear brake.
5. Push the start switch button  (1) for a few seconds.

CAUTION

- Do not crank the engine more than 5 seconds on any attempt.
- The engine starts immediately upon actuation of the starter, then wait a few seconds before you try to start it again. Each starting process should be as short as possible in order to save battery and the starter.

STARTING OFF

CAUTION

Before starting off, allow the engine to warm up to avoid damages.

1. Sit astride the seat, and then adjust the rear view mirrors.
2. Switch the turn signal on to the direction you wish to turn.
 1. Pull the clutch lever
 2. Shift the engine to the first gear
 3. Check for oncoming traffic.
 4. Slowly release the clutch lever and open the throttle at the same time.
 5. Switch the turn signal off.

SHIFTING AND RIDING

a) Shifting gears upwards

1. Release the throttle
2. Pull the clutch lever
3. Lift the gear lever upwards to change to the higher gears.
4. Slowly release the clutch lever and open the throttle at the same time.

b) Shifting gears downwards

1. Release the throttle
2. Operate the brakes and reduce the speed to a appropriate speed.
3. Pull the clutch lever
4. Lift the gear lever down wards to change to the lower gears.
5. Slowly release the clutch lever and open the throttle at the same time.

⚠ WARNING

Always switch one gear only, otherwise the transmission can be damaged.

OPERATION AND IMPORTANT RIDING POINTS

ACCELERATION / DECELERATION

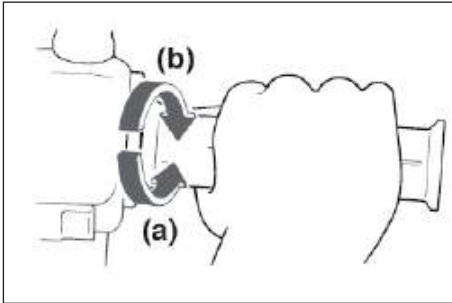

The speed can be adjusted by opening and closing the throttle. To increase the speed, turn the throttle grip in direction (a). To reduce the speed, turn the throttle grip in direction (b).

BRAKING

1. Release the throttle.
2. Apply the clutch lever gradually increasing the pressure.
3. Apply the front and rear brake at the same time.

⚠ WARNING

- **Avoid braking hard and/or suddenly, otherwise the vehicle may skid.**
- **Railroad crossings, streetcar rails, iron plates on road construction sites, and manhole covers become extremely slippery when wet. Therefore, slow down when approaching such areas and cross them with caution.**
- **Keep in mind that braking on a wet road is much more difficult.**
- **Ride slowly down a hill, as braking downhill can be very difficult.**

STOP THE ENGINE / PARKING

1. Reduce the throttle to 0 position.
2. Pull the clutch lever
3. Switch the gear to **N** - neutral
4. Operate the brakes
5. After the vehicle is stopped turn off the ignition.
6. Lower the side stand with your foot while holding the motorcycle up-

right. Remove the key from the main switch.

⚠ WARNING

Since the engine and exhaust system can become very hot, park in a place where pedestrians or children are not likely to touch them. Do not park on a slope or on soft ground, otherwise the vehicle may overturn.

ENGINE BREAK IN

During the first 1000 km do not ride the vehicle over 75% of its maximum speed.

Avoid opening the accelerator completely and varies speed repeatedly over long distances.

After the first 1000 km increase speed gradually until reaching maximum performance.

CAUTION

- The durability and the efficiency of your scooter depend strongly on the care received during the run-in pe-

OPERATION AND IMPORTANT RIDING POINTS

riod. The mechanisms of the mobile parts are mutually hardened and adapted.

- After better run-in is obtained not by riding slowly but softly and carefully. During this period, it is advisable to ride the vehicle at $\frac{3}{4}$ of maximum performance. In the event that full acceleration is necessary (overtaking maneuvers, steep slopes, etc.) try to limit the time to a minimum.
- Gearbox oil must be changed once the first 1000 km are covered. Use the recommended oil type and specified quantity only.

The durability and the efficiency of your scooter depend strongly on the care received during the run-in period. The mechanisms of the mobile parts are mutually hardened and adapted.

After better run-in is obtained not by riding slowly but softly and carefully. During this period, it is advisable to ride the vehicle at $\frac{3}{4}$ of maximum performance. In the event that full acceleration is necessary (overtaking maneu-

vers, steep slopes, etc.) try to limit the time to a minimum.

Gearbox oil must be changed once the first 1000 km are covered. Use the recommended oil type and specified quantity only.

To obtain optimum adjustment of mobile parts, a long life and better performance, it is necessary not to force the vehicle during the 1000 km.

The vehicle must have a suitable run-in period, during which the following precautions must be considered:

- After starting the engine, warm it up progressively, without maximum acceleration (we recommend not to exceed $\frac{3}{4}$ of the throttle grip opening for 1st gear) or overcharge.
- In long stretches, do not use full speed consistently and varies the speed repeatedly.
- When facing steep slopes, downshift to have better power.
- After a long run do not stop the engine suddenly, leave it running at minimum acceleration for some se-

conds.

- Check the non-existence of oil, fuel or brake liquid leaks.
- In case of anomalous noise, try to identify its cause immediately.

PERIODIC MAINTENANCE AND MINOR REPAIR

CAUTION

Most of the Safety and condition of vehicle depend on how you do the correct maintenance , periodic inspection, adjustment and lubrication. The following are contents that help the operator to do such skills on the following pages.

WARNING

Maintenance, replacement, or repair of the emission control devices and systems may be performed by any repair shop or individual that is certified and must follow the local law regulations.

If you are not familiar with maintenance work, have a dealer do it for you.

SPARK PLUG

The spark plug is an important engine component, which is easy to check. Since heat and deposits will cause any spark plug to slowly erode, the spark

plug should be removed and checked in accordance with the periodic maintenance and lubrication chart. In addition, the condition of the spark plug can reveal the condition of the engine.

The spark plug is on the right, front side of the vehicle.

Check the spark plug

1. Remove the spark plug cap
2. Remove the spark plug as shown, with a spark plug wrench.



3. Check that the porcelain insulator (3) around the center electrode of the spark plug is a medium-to-light tan (the ideal color when the vehicle is ridden normally).

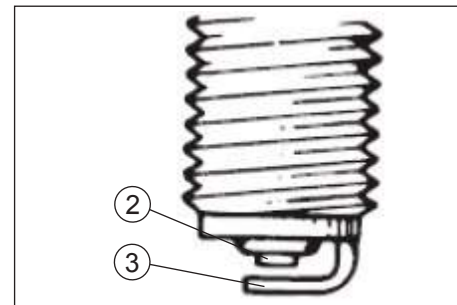

CAUTION

If the spark plug shows a distinctly different color, the engine could be operating improperly. Do not attempt to diagnose such problems yourself. Instead, have a dealer check the vehicle.

4. Check the spark plug for electrode erosion and excessive carbon or other deposits, and replace it if necessary.

PERIODIC MAINTENANCE AND MINOR REPAIR

Specified spark plug: D8RTC

⚠ WARNING

Please note that no other spark plug model is allowed. Using a different spark plug model can immediately lead to engine damage.

5. Measure the spark plug gap with a wire thickness gauge and, if necessary, adjust the gap to specification. Clean the surface of the spark plug gasket and its mating surface, and then wipe off any grime from the spark plug threads.
6. Install the spark plug with the spark plug wrench, and then tighten it to the specified torque.

Spark plug gap: 0,6 - 0,7 mm

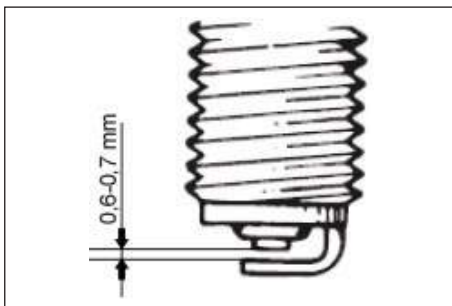

⚠ WARNING

Please note the max. torque when inserting the plug. If you do not have the ability to control you leave control of the spark plug to the dealer.

ENGINE OIL

It is recommended to check the engine oil level before each operation of the vehicle. Use a high-quality engine oil and change it according to the maintenance table to extend the life of your engine.

Check engine oil

1. Run the engine.
2. Position the vehicle on its centre stand.
3. After approximately 3 minutes switch off the engine and wait one minute.
4. Check the oil level on the oil dip stick. Screw out the oil dip stick, clean it with a dry cloth and plug it in. Do not screw it in when checking the oil level. The oil level must be between the max and min marks.
5. After checking the oil level screw in the oil dip stick.

Capacity:

1,0 L

4-stroke engine oil

Recommended engine oil:

Liqui Moly Motorbike 4T 10W-40

⚠ WARNING

At each refuelling you have to control the engine oil.

PERIODIC MAINTENANCE AND MINOR REPAIR

CAUTION

In dusty, cold or poor road conditions, the condition of the oil deteriorates more rapidly. Oil changes should therefore be carried out more frequently.

Oil change

The engine oil can be topped up whenever this is needed but oil changes and oil filter replacements should be carried out by a specialised dealer because mistakes while carrying out this work could result in engine damage.

⚠ WARNING

- **Make sure that no foreign material enters the housing.**
- **Make sure that no oil gets on the tire or wheel.**

FUEL FILTER

The petrol filter is located directly next to the petrol tap underneath the fuel tank. Handling the petrol filter is hazardous as petrol may escape.

CAUTION

Have the replacement carried out by a specialised dealer.

AIR FILTER



The air filter should be replaced according to the maintenance schedule.

Replace the air filter more often if you drive in unusually wet or dusty areas.

CAUTION

- The air filter should be cleaned dry or using only a specially formulated cleaning agent.
- Make sure that the air filter element is properly seated in the air filter case.
- The engine should never be operated without the air filter element installed, otherwise the piston and/or cylinder may become excessively worn.
- If necessary, have the air cleaner exchanged by the specialist dealer.

ECU (ENGINE CONTROL UNIT)

The ECU is an important part of the engine and its emission control system, which requires very sophisticated adjustment. Therefore, ECU adjustments should be left to dealer, who has the necessary professional knowledge and experience.

PERIODIC MAINTENANCE AND MINOR REPAIR

THROTTLE CABLE FREE PLAY

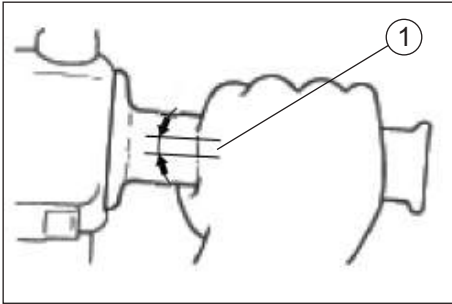

The throttle cable free play (1) should measure 1.5 ~ 3.5 mm at the throttle grip.

CAUTION

Periodically check the throttle cable free play and, if necessary, have a dealer adjust it.

Throttle cable free play adjustment

1. Release the locknut (1)
2. Rotate the adjusting nut (2) to adjust the clearance.
3. Tighten the lock nut (1) after adjusting the nut (2).

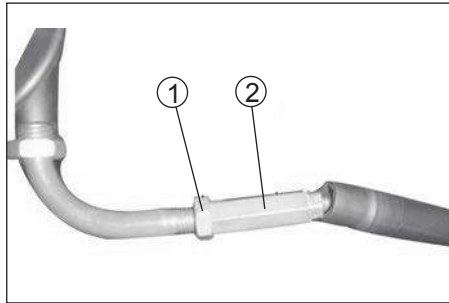

CLUTCH FREE PLAY

The clutch free play should be 10-20mm.

CAUTION

Periodically check the clutch free play and, if necessary, have a dealer adjust it.

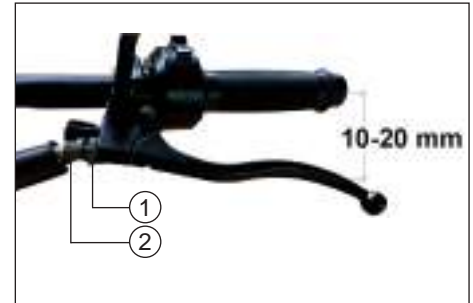

Clutch free play adjustment

1. Loosen the locknut (1)
2. Turn the adjusting bolt (2) and the adjusting nut (3) in or out to meet the requirements of clutch free play.
3. Tighten the lock nut (1) after adjusting the nut (2).

PERIODIC MAINTENANCE AND MINOR REPAIR

TIRES

To maximize the performance, durability, and safe operation of your vehicle, note the following points regarding the specified tires.

Tire air pressure

The tire air pressure should be checked and, if necessary, adjusted before each ride.

⚠ WARNING

The tire air pressure must be checked and adjusted on cold tires (i.e., when the temperature of the tires equals the ambient temperature). The tire air pressure must be adjusted in accordance with the riding condition. If you are not familiar to this, please have dealer for help.

Tire air pressure*:

Front: 2,5 bar

Rear: 2,5 bar

*The tire pressure depends on the applied payload

Maximum load*: 150kg

*Total weight of rider, passenger, cargo and accessories

⚠ WARNING

Do not over load your vehicle, since it will increase pressure on the tire, braking, steering than original design, and may could cause damage or even lead to accident.

Allocation of your cargo and weight of your vehicle is very important for your own safety and vehicle performance. Load your cargo rmlly on vehicle and put the heaviest cargo to the center of vehicle, then distribute the weight evenly from side to side. It will keep you to have good steering after load.

Tire inspection

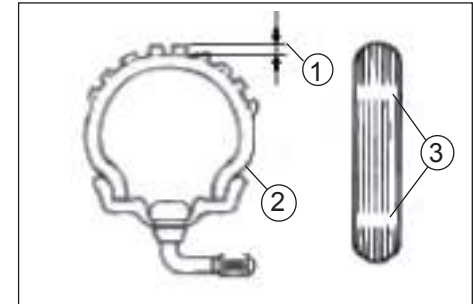

1. Tire tread depth
2. Tire sidewall
3. Tire wear indicator

⚠ WARNING

The tires must be checked before each ride. If a tire tread shows crosswise lines (minimum tread

PERIODIC MAINTENANCE AND MINOR REPAIR

depth), if the tire has a nail or glass fragments in it, or if the sidewall is cracked, have a dealer replace the tire immediately.

CAUTION

The tread depth may vary depending on country. Observe local regulations. The values listed here are technical values and may differ from the legal values of your region.

Technical tire tread depth:

Front and rear: Min. 1,6 mm

⚠ WARNING

- **Drive with worn tire is illegal, reduces stability and can lead to loss of control over the vehicle.**
- **Let worn or damaged tires replaced immediately by your dealer.**
- **Working tires and the dealer is responsible.**

Tire Dimensions:

Front

Tire: 100/90-18
(Optional: 4,00-17)

Rear

Tire: 120/80-17
(Optional: 4,50-17)

RIMS

To maximize the performance, durability, and safe operation of your motorcycle, note the following points regarding the specified wheels.

- The wheel rims should be checked for cracks, bends or warpage before each ride. If any damage is found, have a dealer replace the wheel. Do not attempt even the smallest repair to the wheel. A deformed or cracked wheel must be replaced.
- The wheel should be balanced whe-

never either the tire or wheel has been changed or replaced. An unbalanced wheel can result in poor performance, adverse handling characteristics, and a shortened tire life.

- Ride at moderate speeds after changing a tire since the tire surface must first be “broken in” for it to develop its optimal characteristics.

BRAKES

⚠ WARNING

A soft or spongy feeling in the brake lever can indicate the presence of air in the hydraulic system. If there is air in the hydraulic system, have a dealer bleed the system before operating the motorcycle. Air in the hydraulic system will diminish the braking performance, which may result in loss of control and an accident.

Brake free play

- The free play of the front brake should be 10-20mm.

PERIODIC MAINTENANCE AND MINOR REPAIR

- The free play of the rear brake should be 20-30mm.

CAUTION

If there is no play of the brake levers, it may be that the brake pads drag permanently on the brake disc. Periodically check the brake lever free play and, if necessary, adjust it as follows.

BRAKE PADS

The front brake pads and the rear brake shoes must be checked for wear at the intervals specified in the periodic maintenance and lubrication chart.

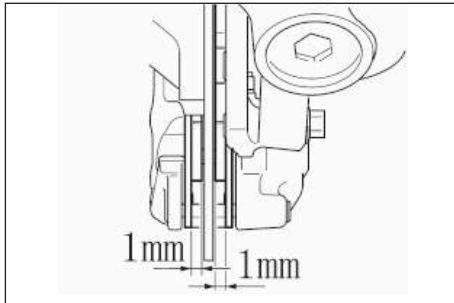

Brake pads

Each brake pad is provided with wear indicators, which allows you to check the brake pad wear without having to disassemble the brake. To check the brake pad wear, check the position of the wear indicators while applying the brake.

If a brake pad has worn to the point that a wear indicator almost touches the brake disc, have a dealer replace the brake pads as a set.

BRAKE FLUID

⚠ WARNING

Insufficient brake fluid may allow air to enter the brake system, possibly causing it to become ineffective. Before riding, check that the brake fluid is above the minimum level mark and refill it if necessary.

- Low position brake fluid level may indicate worn brake pads and/or brake system leakage.

- If the brake fluid level is low, be sure to check the brake pads for wear and the brake system for leakage.
- When checking the fluid level, make sure that the top of the master cylinder is level by turning the handlebars.
- Use only the recommended quality brake fluid, otherwise the rubber seals may deteriorate, causing leakage and poor braking performance.

DOT 4 brake fluid
(Only use brake fluid out of an unopened container)

Recommended:
Liqui Moly DOT 4 brake fluid

- Refill with the same type of brake fluid. Mixing fluids may result in a harmful chemical reaction and lead to poor braking performance.

PERIODIC MAINTENANCE AND MINOR REPAIR

mance.

- Be careful that water does not enter the master cylinder when refilling. Water will significantly lower the boiling point of the fluid and may result in vapor lock.
- Brake fluid may deteriorate painted surfaces or plastic parts. Always clean up spilled fluid immediately.
- As the brake pads wear, it is normal for the brake fluid level to gradually go down. However, if the brake fluid level goes down suddenly, have a dealer check.

Changing the brake fluid

WARNING

Have a dealer change the brake fluid at the intervals specified in the NOTE after the periodic maintenance and lubrication chart.

CABLES

The operation of all control cables and the condition of the cables should be checked before each ride, and the cables and cable ends should be lubricated if necessary. If a cable is damaged or does not move smoothly, have a dealer check or replace it.

WARNING

Damage to the outer housing of cables may result in internal rusting and cause interference with cable movement.

Replace damaged cables as soon as possible to prevent unsafe conditions.

THROTTLE GRIP AND CABLE

The operation of the throttle grip should be checked before each ride. In addition, the cable should be lubricated at the intervals specified in the periodic maintenance chart.

LUBRICATING THE BRAKE LEVER AND BRAKE PEDAL

The pivoting points of the brake lever and brake pedal must be lubricated at the intervals specified in the periodic maintenance and lubrication chart.

SIDE STAND / MAIN STAND

CAUTION

The operation of the side stand / main stand should be checked before each ride, and the pivots and metal-to-metal contact surfaces should be lubricated if necessary.

WARNING

If the side stand / main stand does not move up and down smoothly, have a dealer check or repair it.

FRONT FORK

The condition and operation of the front fork must be checked as follows at the intervals specified in the periodic maintenance and lubrication chart.

PERIODIC MAINTENANCE AND MINOR REPAIR

⚠ WARNING

Securely support the motorcycle so that there is no danger of it falling over.

1. Place the vehicle flat and upright from.
2. Check the inner tubes for scratches, damage and oil leakage.
3. Apply the front brake and push the handlebars several times down hard to verify the suspension of the fork.

⚠ WARNING

- If the fork is damaged, please contact your dealer.
- If you treat the telescopic fork with cleaning agents, make sure that they get no contact with the tires or the brakes. This can lead to dangerous accidents.

STEERING

⚠ WARNING

Worn or loose steering bearings may cause danger. Therefore, the operation of the steering must be checked as follows at the intervals specified in the periodic maintenance and lubrication chart.

1. Place the vehicle on a suitable motorcycle stand to raise the front wheel off the ground.
2. Hold the lower ends of the front fork legs and try to move them forward and backward.
3. If any free play can be felt, have a dealer check or repair the steering.

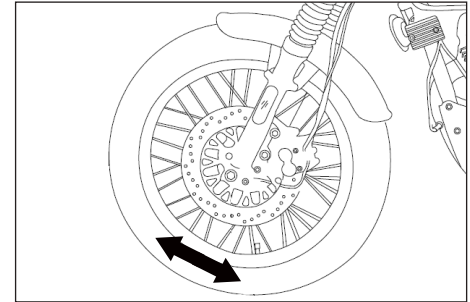

WHEEL BEARINGS

The front and rear wheel bearings must be checked at the intervals specified in the periodic maintenance and lubrication chart.

CAUTION

If there is play in the wheel hub or if the wheel does not turn smoothly, have a dealer check the wheel bearings.

PERIODIC MAINTENANCE AND MINOR REPAIR

DRIVE CHAIN

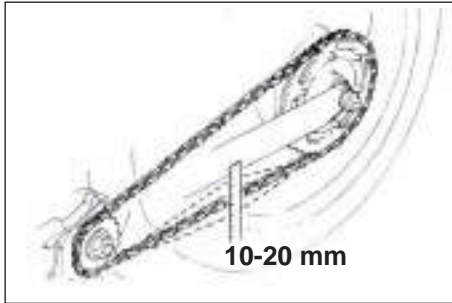

If the chain tension is too great, parts within the secondary power transmission (chain, chain sprockets transmission and rear wheel bearings) will be subjected to unnecessary stress resulting in early wear and even chain breakage. Too much slack in the chain, on the other hand, can result chain jumping off the chain wheels. If this happens the chain could also block the rear wheel or damage the engine. In either case the operator is likely to lose control of the vehicle.

Tensioning the chain drive

1. Loosen axle nut
2. Loosen counter nut
3. Turn right and left adjusting screws equally far
4. Turn the adjusting screws, on the right and left side of the tire, to set the correct free play. The drive chain free play should be between 10 mm and 20 mm
5. Tighten the counter nut and the collar nut.

BATTERY

⚠ WARNING

- **Do not remove the battery vent seal, this can be dangerous, the battery permanently damaged.**
- **Battery acid is poisonous and dangerous, it contains sulfuric acid and leads to dangerous burns.**
- **Avoid skin, eye and clothing contact. Protect your eyes always when working near the battery.**
- **Upon contact with the battery**

acid, make immediate FIRST AID.

- **If skin or eye contact with battery acid, rinse the affected areas with plenty of water.**
- **When accidentally swallowed battery acid drink large amounts of water.**
- **In both cases, as soon as possible, see a doctor.**
- **Batteries develop explosive hydrogen gas. Keep open flames, smoking materials away from the battery and make sure there is adequate ventilation when you charge a battery indoors.**
- **KEEP THIS AND ALL BATTERIES OUT OF THE REACH OF CHILDREN.**

Charge the battery

Have a dealer charge the battery as soon as possible if it seems to have discharged. Keep in mind that the battery tends to discharge more quickly if the vehicle is equipped with optional electrical accessories.

PERIODIC MAINTENANCE AND MINOR REPAIR

Store the battery

- If the vehicle will not be used for more than one month, remove the battery, fully charge it, and then place it in a cool, dry place.
- If the battery will be stored for more than two months, check it at least once a month and fully charge it if necessary.
- Fully charge the battery before installation.
- After installation, make sure that the battery leads are properly connected to the battery terminals.

⚠ WARNING

Please contact your dealer if you are not familiar with handling the battery.

CAUTION

Always keep the battery charged. Storing a discharged battery can cause permanent battery damage.

FUSE

Replacing the fuse

1. Turn the ignition and all electrical circuits off.
2. Remove the blown fuse, and then install a new fuse of the specified amperage.

⚠ WARNING

Do not use a fuse of a higher amperage rating than recommended to avoid causing extensive damage to the electrical system and possibly a fire.

3. Turn on the ignition and check if all devices operate.
4. If the fuse immediately blows again, have a dealer check the electrical system.

LIGHTING

Headlight

This model is equipped with halogen bulb headlight. If a headlight bulb burns out, have a dealer replace it and, if necessary, adjust the headlight beam.

Turn signal, Tail and Brake light

The turn signals, the tail and the brake lights are equipped with an LED light. If one of these lights does not come on, contact a dealer to check the electrical circuit.

License plate light

If the license plate light (5) do not glow, remove the glass and change the bulb or please contact your dealer to replace it.

TROUBLESHOOTING

Although the vehicles receive a thorough inspection before shipment from the factory, trouble may occur during operation. Any problem in the fuel, compression, or ignition systems, for example, can cause poor starting and loss of power.

The following troubleshooting chart represents a quick and easy procedure for checking these vital systems yourself. However, should your vehicle require any repair, take it to a dealer, whose skilled technicians have the necessary tools, experience, and knowhow to service the vehicle properly.

Use only genuine replacement parts. Imitation parts may look like parts, but they are often inferior have a shorter service life and can lead to expensive repair bills.

WARNING

Keep away open flames and do not smoke while checking or working on the fuel system.

TROUBLESHOOTING CHART

Failure	Cause	To Do
Engine does not start when the electric starter button is pushed	Battery discharged	Charge the battery
		Check the charging of the battery
		Check if the generator is working correctly
	Fuse is blown	Change the fuse
	Starter relay defective	Check the starter relay
Engine turns but does not start or dies off	Starter motor defective	Check the starter motor
	Wrong assembly of roll over sensor	Check roll over sensor position
	A fuse is blown	Check the fuses
	Idle speed is not set correctly	Adjust the idle speed
	Spark plug is contaminated	Clean the spark plug, check the electrode distance
Failure in ignition system	Check the ignition system	

TROUBLESHOOTING

TROUBLESHOOTING CHART

Failure	Cause	To Do
Engine turns but does not start or dies off	Wire harness is worn	Check the wiring harness
	Contact problem in a plug	Check the plugs of the wiring harness
	No gasoline in the tank	Refill gasoline
	Problem with the fuel pump	Check the pump
	Fuel leakage	Check the fuel circuit
Engine power is poor	Air filter contaminated	Clean the filter
	Fuel filter contaminated	Clean the filter
	Failure in fuel system	Check the fuel system
	Valve clearance too little	Adjust valve clearance
Engine overheats	Long operating time at higher engine speed but low or no driving speed	Let the engine cool down, avoid such driving behavior, especially in city traffic
To high oil consumption	Engine oil level too high	Bleed the oil system
	Cylinder/Piston is worn	Replace the cylinder/piston
	Engine vent hose bent	Correct the layout of the hose
Engine warning light is on	Failure in the fuel injection/electric system	Contact your dealer to identify the failure

CLEAN AND STORAGE

CLEAN THE VEHICLE

Clean of the vehicle in a proper and suitable way will make it more attractive, extend it's life and optimize the performance.

Before cleaning

1. Cover the muffler outlet with a plastic bag to prevent water to come inside. Please do it only after the
2. Close every caps, covers, electrical connectors that are well install and water can be avoid to get into, while you do the clean job.

CAUTION

- Do not use acid-based cleaners. If such funds used for stubborn stains, so use this only occasionally, dry it immediately after and then apply a corrosion protection spray.
- Always follow the manufacturer's instructions on care and cleaning agents.
- Use best only water and mild detergent or special cleaner from the

dealer to the sensitive components of the vehicle to prevent damage. Dry the plastic parts then wipe with a soft, dry cloth or sponge.

- Protect particularly plastic parts, paint, headlight glass from harsh chemicals such as fuel, rust remover, brake cleaner or similar. The use of such agents may result in malfunction, damage and affect the security itself.
- Do not use a high pressure washer or steam cleaner, causing water in storage can penetrate electrical components such as connectors or switches, lighting, ventilation hoses, brake shoes and brake linings or damage, seals, paint and other surfaces.

Cleaning after normal use

Remove dirt with warm water, a mild detergent, and a soft, clean sponge, and then rinse thoroughly with clean water. Use a toothbrush or bottlebrush for hard-to-reach areas.

Cleaning after riding in the rain, near the sea or on salt-sprayed roads

CAUTION

Since sea salt or salt sprayed on the roads during winter are extremely corrosive in combination with water, carry out the following steps after each ride.

- Wait until the engine / exhaust have cooled.
- Clean the vehicle with warm water and a mild detergent.
- Do not use hot water, which increases the corrosive effect of the salt.
- Apply a corrosion protection spray on all metal, including chrome- and nickel-plated, surfaces to prevent corrosion.

CLEAN AND STORAGE

After cleaning

- Dry the vehicle.
- To prevent rust, we recommend appropriate care to use according to manufacturer's instructions.
- Wax all painted surfaces.

⚠ WARNING

- **Make sure that there is no oil or wax on the brakes or tires.**
- **If necessary, clean the brake discs and brake linings with a regular brake disc cleaner and wash the tires with warm water and a mild detergent.**
- **Before operating the vehicle, test the braking performance and tires.**

STORAGE

Short-term (for a few days)

- Always store your vehicle in a cool, dry place and, if necessary, protect it against dust with a vehicle cover.

⚠ WARNING

Please store the vehicle in a well air flow room with dry air if possible. A place with wet humidity will cause rust.

Long-term (for weeks)

- Clean the vehicle.
- Drain the fuel from the carburetor.
- Enter the drained fuel back into the fuel tank.
- Fill the fuel tank to completely or add if necessary a fuel stabilizer to protect the fuel tank from rusting and the fuel from degradation.

Follow the steps below to cylinders, piston rings, etc. to prevent rusting.

- Remove spark plug cap and the spark plug.
- Give a teaspoon of engine oil into the spark plug hole.
- Join the Kickstarter to slow down and let the engine several times slowly rotate (thus the cylinder is oiled).
- Put the spark plug back in and put on the spark plug cap.

⚠ WARNING

Please make sure that during this activity the spark plug to metallic no contact Parts has on the vehicle. Wait all ropes, cables and the pivot points of the levers, the footrests as of kickstand as described.

- Check and correct tire pressure and lift the vehicle off the ground, so that neither of the two wheels is on the ground. If this is not possible, turn the wheels every month a little further, so they do not constantly the same place standing (Stand damage).

CLEAN AND STORAGE

- Slide a plastic bag over the exhaust to prevent moisture from entering.
- Remove the battery and load it as described on. Store cool the battery and dry and upload to this every 2 months. Store the battery is not excessively cold or hot (Below 0 ° C or above 30 ° C).

CAUTION

Always perform necessary repairs before storage

Recommended maintenance products:

Liqui Moly:

Motorbike Cleaner
Motorbike Gloss Spray Wax
Motorbike Chain Lube
Motorbike Multi-Spray
Motorbike Gasoline Stabilizer

SPECIFICATIONS

ENGINE	
Type	4-stroke, OHC air cooled
Cylinder arrangement	Forward-inclined single cylinder
Displacement	124.8 cm ³
Compression ratio	9.3:1
Starting system	Electric starter
Lubrication system	Wet sump lubrication

OIL	
Engine oil	
Type	4-stroke engine oil
Recommendation	Liqui Moly Motorbike 4T 10W-40
Quantity	1.0 l

FUEL	
Type	Unleaded gasoline only
Quantity	14L +/- 0,5 L



!! BIOETHANOL FUEL - E10 IS NOT PERMITTED !!

SPARK PLUG	
Type	D8RTC
Spark plug gap	0,6 - 0,7 mm

CLUTCH	
Clutch type	Multiple plate clutch
Transmission type	5 - speed constant mesh transmission

CHASSIS	
Type	Steel tube

TIRES		
	BX 125, BX 125 X, BX 125 H	BX 125 R
Front tire		
Tyre	100/90-18	4.00-18
Wheel	2.50x18	2.50x17
Tire air pressure	2,5 bar	2,5 bar
Rear tire		
Tyre	120/80-17	4.50-17
Wheel	3.00x17	3.00x17
Tire air pressure	2,5 bar	2,5 bar

SPECIFICATIONS

BRAKE SYSTEM

Type	Single Hydraulic disc brake
Operation front	Right hand / Right foot (CBS)
Operation rear	Right foot
Brake fluid	
Type	DOT 4
Recommended	Liqui Moly DOT 4 brake fluid

SUSPENSION

Front suspension	
Type	Telescopic fork
Rear suspension	
Type	Unit swing

ELECTRIC SYSTEM

Ignition system	ECU
Charging system	Magneto

BATTERY

Voltage / Capacity	12 V, 10 Ah
--------------------	-------------

LAMPS

Headlight	12 V, 35 W / 35 W
Tail light / Brake light	LED
Front turn signal light	LED
Rear turn signal light	LED
License plate light	LED

FUSE

Main fuse	15 A
-----------	------

DIMENSIONS

	BX 125	BX 125 R	BX 125 X	BX 125 H
Length	2020 mm	2020 mm	2020 mm	2020 mm
Width	850 mm	760 mm	870 mm	760 mm
Height	1105 mm	1060 mm	1105 mm	1135 mm
Wheelbase	1320 mm	1320 mm	1320 mm	1320 mm

MASS

Mass in running order	134 kg
axleload front	58 kg
axleload rear	76 kg
Max. permissible load	284 kg

WARRANTY INFORMATION

Please carefully read the instruction manual of your vehicle before operating it in order to make yourself familiar with its handling. We explicitly point out that the instruction, maintenance, and care instructions given in the operating manual have to be complied with in order to sustain your claim towards warranty. Only the strict compliance with customer specifications stated in the instruction manual ensures the prolonging of the natural life of your vehicle. Starting with the date of the invoice a limited warranty of 24 months is granted regarding the accuracy of the vehicle in terms of material and manufacturing according to latest standards. The legal warranty regulations will not be restricted by this limited guarantee. Maintenance work has to be exclusively done by authorized workshops entitled by us. Warranty in general is bound to the region of invoicing and can therefore only be carried out within the country the vehicle was bought. Damages that can be traced back to inappropriate usage, manipulation, or neglecting of the maintenance/care/operating instructions will not be covered by warranty. Warranty can only be granted if occurring damages are immediately being reported to the seller or any other authorized workshop by the buyer. The warranty claim entitles the buyer to remedy deficiencies or to the reparation respectively the exchange of a damaged part in an authorized workshop after our approval. Compensation for remote or instantaneous damages cannot be granted. Vehicles in desolate condition will not be covered by warranty. Repair works carried out on warranty do not enlarge the guarantee period. Only this document entitles you to call on warranty services. Therefore please make sure that you are delivered this fully filled in document by the seller and that he has registered your vehicle correctly in our system. Please also mind the following advices.

Body and panelling of the vehicle have to be kept free of dirt constantly. Do not use high pressure water blasters, strong jets of water, sharp and corrosive or other aggressive detergents which could harm surfaces and varnish permanently and foster corrosion. It is vital to use protecting cleansers. Please consult our dealers for the right and appropriate products. Aluminium parts or other refined parts (chrome parts, anodized parts or other processed surfaces) have to be treated with appropriate maintenance products in order to prevent oxidation. Frame and metal parts are continuously to be treated with anticorrosive. A vehicle constantly parked outside has to be covered to avoid weathering and crack formations on seat and plastic parts. Vehicles used off-road and for racing purposes are excluded from warranty.

Material which is to be used in the context of service and maintenance works are excluded from warranty as well as the following parts: incandescent bulbs, brake pads, clutch lining, filter elements, spark plugs, drive sprocket, wheel and axle., as well as the tires.

SERVICE AND MAINTENANCE

IMPORTANT INFORMATION

The date for the implementation of maintenance depends on whichever limit is reached first. That means either the driven kilometers or the duration from initial startup.

The warranty can be granted only when the vehicle is serviced in accordance with this plan and was not exposed to extraordinary stress.

⚠ WARNING

Only appropriate works which are intended for your vehicle perform.

CAUTION

Spark plug, fuel filter and air filter must be replaced every 7000 km.

Hydraulic lines should be replaced every 4 years.

The brake fluid should be changed every 2 years.

From 13000km or the 4. year, the inspection should take place at least once a year or every 3000km.

The vehicle must continuously be checked for rust. The vehicle owner is responsible for rust prevention.

On the following pages you will find the maintenance schedule and the service record.

SERVICE AND MAINTENANCE

MAINTENANCE SCHEDULE

The inspection intervals are required, these will void the warranty.		1000km	4000km or 1. year	7000km or 2. year	10000km or 3. year	13000km or 4. year
COMPONENT	PERFORM					
Airfilter	Clean/ Exchange	✓	✓	Exchange	✓	✓
Wheels, Rims	Control	✓	✓	✓	✓	✓
Tire	Control of tread depth / Pressure		✓	✓	✓	✓
Wheel bearing	Control/ Exchange		✓	✓	✓	✓
Steering bearing	Control/ Clean / Lubricate	✓	✓	✓	Lubricate	✓
Screws Coverparts	Control/ Retighten		✓	✓	✓	✓
Brake system	Control/ Clean / Exchange		✓	✓	✓	✓
Side stand	Control/ Clean / Lubricate		✓	✓	✓	✓
Telescopic fork	Control		✓	✓	✓	✓
Shock absorber rear	Control		✓	✓	✓	✓
Oil strainer / Spin filter	Clean	✓		✓		✓
Engine oil / Oil filter	Exchange / Control	Exchange	✓	Exchange	✓	Exchange
Transmission oil (if available)	Exchange	✓		✓		✓
Valves	Control / Adjust	✓	✓	✓	✓	✓
Drive chain / Pinion	Control / Clean / Exchange	✓	✓	✓	✓	✓
Clutch	Control	✓	✓	✓	✓	✓
Cables / Bowden	Control / Clean / Lubricate	✓	✓	✓	✓	✓
Throttle	Control / Adjust / Lubricate		✓	✓	✓	✓
Lights / switch	Control / Adjust	✓	✓	✓	✓	✓
Fuel line / Filter	Control / Exchange		✓	Exchange	✓	✓
Idle speed	Control / Adjust	✓	✓	✓	✓	✓
Exhaust system	Control / Retighten		✓	✓	✓	✓

SERVICE AND MAINTENANCE

SERVICE RECORD

In the delivery of the vehicle the customer data and vehicle data must be supplemented.

<p>Maintenance interval: <i>Delivery inspection</i></p> <p>Odometer reading: _____</p> <p>Date: _____</p> <p>Stamp / Signature</p>	<p>Maintenance interval: <i>1000 km</i></p> <p>Odometer reading: _____</p> <p>Date: _____</p> <p>Stamp / Signature</p>	<p>Maintenance interval: <i>4000 km or 1. year</i></p> <p>Current odometer reading: _____</p> <p>Date: _____</p> <p>Stamp / Signature</p>
<p>Maintenance interval: <i>7000 km or 2. year</i></p> <p>Odometer reading: _____</p> <p>Date: _____</p> <p>Stamp / Signature</p>	<p>Maintenance interval: <i>10000 km or 3. year</i></p> <p>Odometer reading: _____</p> <p>Date: _____</p> <p>Stamp / Signature</p>	<p>Maintenance interval: <i>13000 km or 4. year</i></p> <p>Odometer reading: _____</p> <p>Date: _____</p> <p>Stamp / Signature</p>
<p>Maintenance interval: <i>16000 km</i></p> <p>Odometer reading: _____</p> <p>Date: _____</p> <p>Stamp / Signature</p>	<p>Maintenance interval: <i>19000 km</i></p> <p>Odometer reading: _____</p> <p>Date: _____</p> <p>Stamp / Signature</p>	<p>Maintenance interval: <i>22000 km</i></p> <p>Odometer reading: _____</p> <p>Date: _____</p> <p>Stamp / Signature</p>

VEHICLE IDENTIFICATION NUMBER : _____ NAME OF THE CUSTOMER: _____

MODEL: _____ SIGNATION OF THE CUSTOMER: _____



SPACE FOR NOTES

Recommended:



Copyright © 2018

All rights reserved.

This user manual is copyrighted.

Copying in mechanical, electronic or any other form without the written permission of the manufacturer is prohibited.

Distributed by:

KSR Group GmbH
Im Wirtschaftspark 15
3494 Gedersdorf
Austria

The copyright is owned by the Company / Manufacturer:

KSR Group GmbH
Im Wirtschaftspark 15
3494 Gedersdorf
Austria

Product and specifications are subject to change without notice.