

宗申产业集团有限公司 ZONGSHEN INDUSTRIAL GROUP			文件名称	维修手册					页码		
			产品型号	ZS250GY-3(电喷)					1/1		
					产品代号		版本号				
					阶段标记			01			
标记	处数	更改文件号	签字	日期	L	C	S	D	F	P	V

# 维修手册 (英文)

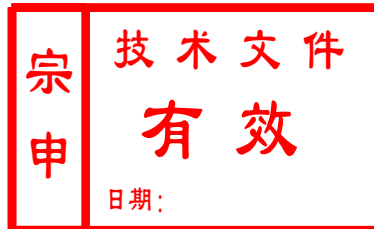

编制	母仕会	2013-9-9	标准化	甘立顺	2013-9-10	文件编号
校对	郭伟	2013-9-10	审定	杨庆春	2013-9-11	08210-M954-C100
审核	宋全刚	2013-9-10	批准	王冲	2013-9-11	基础车型产品代号
会签						



***MOTORCYCLE  
MAINTENANCE MANUAL***  
**ZS250GY-3(EFI)**

# **ZS250GY-3 (EFI)MOTORCYCLE SERVICE MANUAL**

THE FIRST EDITION(Aug,2013)

Zongshen industrial group reserves all rights of  
this service manual.

The specifications and pictures in this manual  
are only for reference.



## INTRODUCTIONS

The manual introduces the structure, working principle, disassembly and inspection, fault diagnosis and elimination. Also, this includes technical specifications, performance parameter and maintenance data. With both the descriptions and pictures, you may have a comprehensive understanding of the configuration as well as the service and repair skill. We hope it can bring technical support and guide to all the users and after service staffs.

Technical specifications, performance parameter and maintenance data mentioned in manual are based upon the latest design features of your motorcycle. Chongqing Zongshen Automobile Industry Co., Ltd. reserves the right to make changes to the specifications of its vehicles without notification. We sincerely hope you can give us your suggestions about the design, manufacture and quality of this type of motorcycle, so that we can do the improvement in time. Thank you for your support and co-operation.

All the specifications, diagram, data and performance index in this manual end in the print of this book. Our company reserves the right to change the book without any notification. All rights are reserved by Zongshen. Any people or companies won't copy it if there is no permission. Otherwise, we will go behind the criminal and legal responsibility.

In this book we take ZS250GY-3 for example to explain the detail of the disassembly, installation, inspection and troubleshooting of this series models. Due to our limited knowledge, it is very possible to have mistakes or omissions in this book. And we welcome your comments.

Chongqing Zongshen Automobile Industry Co., Ltd.  
Address: CHAOYOUCHANG, BANAN DISTRICT, CHONGQING, CHINA.  
Service hotline: 4007003088  
For more information, visit our website [www.zongshenmotor.com](http://www.zongshenmotor.com)

Editor Aug, 2013

-  All rights of this trademark reserved by Zongshen Industrial Group, trademark registration number in china is: 1487149;
-  All rights of this trademark reserved by Zongshen Industrial Group, trademark registration number in china is: 3448029;
-  All rights of this trademark reserved by Zongshen Industrial Group, trademark registration number in china is: 3448027;
-  All rights of this trademark reserved by Zongshen Industrial Group, trademark registration number in china is: 1613961;
-  All rights of this trademark reserved by Zongshen Industrial Group, trademark registration number in china is: 1000532;
-  All rights of this trademark reserved by Zongshen Industrial Group, trademark registration number in china is: 2020397;
-  All rights of this trademark reserved by Zongshen Industrial Group, trademark registration number in china is: 3448028;
-  All rights of this trademark reserved by Zongshen Industrial Group, trademark registration number in china is: 1767202;
-  All rights of this trademark reserved by Zongshen Industrial Group, trademark registration number in china is: 3580941;
-  All rights of this trademark reserved by Zongshen Industrial Group, trademark registration number in china is: 1767247;
-  All rights of this trademark reserved by Zongshen Industrial Group, trademark registration number in china is: 1767201;
-  All rights of this trademark reserved by Zongshen Industrial Group, trademark registration number in china is: 5574208;
-  All rights of this trademark reserved by Zongshen Industrial Group, trademark registration number in china is: 5335140;
-  Zongshen Industrial Group are applying this trademark.
-  This Logo is the combination of registration trademark of Zongshen Industrial Group and registration trademark of PIAGGIO & C.S.P.A. All rights reserved by ZONGSHEN PIAGGIO FOSHAN MOTORCYCLE CO., LTD.
-  This trademark was registered by Zongshen Industrial Group in more than 20 countries such as Nigeria, Argentina and Vietnam, etc.
-  This trademark was registered by Zongshen Industrial Group in more than 90 countries such as Japan, New Zealand, Germany, Canada etc.
-  This trademark was registered by Zongshen Industrial Group in more than 90 countries such as Germany, Cambodia and France, etc.

LIMITED: Without written permission by Zongshen Industrial Group, no company and individual is allowed to copy, duplicate and use above trademarks and logos.



# catalogue

## INTRODUCTION

## CATALOGUE

<b>CHAPTER 1 GENERAL INFORMATION .....</b>	<b>1</b>
section 1 vehicle introduction .....	1
section 2 structure .....	2
<b>CHAPTER 2 MAINTENANCE KNOWLEDGE .....</b>	<b>4</b>
section 1 Attention Items of Maintenance .....	4
section 2 General knowledge of Maintenance .....	5
section 3 Adjusting Data of Maintenance .....	8
<b>CHAPTER 3 VEHICLE .....</b>	<b>10</b>
section 1 Fuel Supply System .....	10
section 2 EFI System .....	13
section 3 Intake and Exhaust system .....	20
section 4 Rear Transmission Device .....	24
section 5 Frame and Accessories .....	28
section 6 Steering System .....	31
section 7 Control Steel Cable .....	32
section 8 Shock Absorber .....	33
section 9 Rear Fork .....	37
section 10 Wheel .....	38
section 11 Brake .....	42
section 12 Meter .....	48
<b>CHAPTER 4 ELECTRICAL .....</b>	<b>50</b>
section 1 Basic Knowledge .....	50
section 2 Power Supply .....	51
section 3 Control .....	54
section 4 Power Consumption .....	57
<b>CHAPTER 5 TROUBLESHOOTING .....</b>	<b>60</b>
<b>APPENDIX: CIRCUIT DIAGRAM .....</b>	<b>74</b>





## CHAPTER 1 GENERAL INFORMATION

### section 1 vehicle introduction

ZS250GY-3 is designed for use on road With futuramic appearance and easy operation. It adopt single cylinder,4-stroke,air cooling engine. This type of engine has the advantages of good cooling,powerful and good acceleration.The frame is pipe joint which has high tensity and good rigidity.The brake system adopts the combination of front and rear disc so that it could ensure the stabilization and safety.And rim type wheel has good appearance and function of anti-abrasion.

**FIGURE 1-1 Left view of motorcycle**

- [1]Front fender
- [2]Front shock absorber
- [3]Steering
- [4]Fuel tank
- [5]Rear armrest
- [6]Front wheel
- [7]Front brake
- [8]Gearshift pedal
- [9]Side stand
- [10]Rear wheel

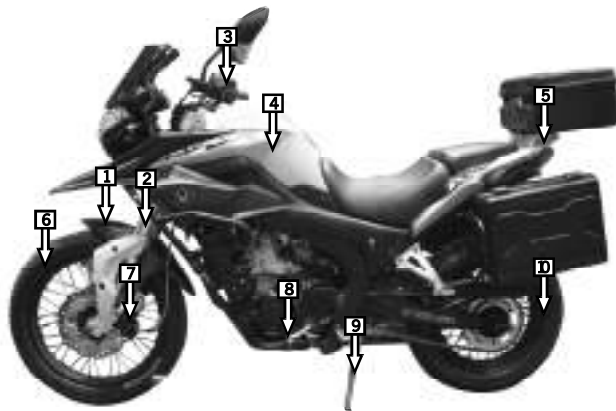

**FIGURE 1-2 Right view of motorcycle**

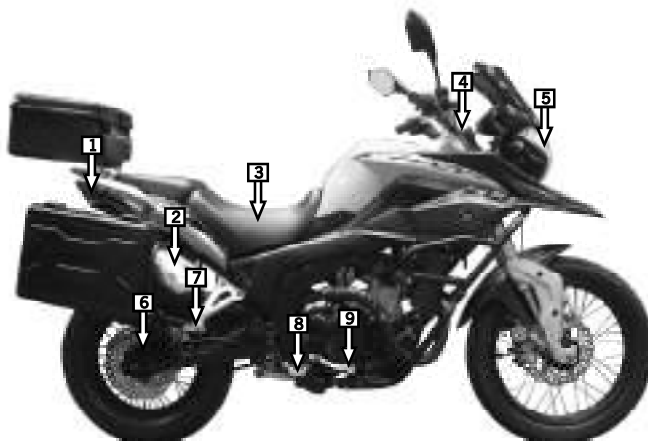

- [1]Taillight assembly
- [2]Muffler
- [3]Seat
- [4]Ignition lock
- [5]Headlight
- [6]Rear brake
- [7]Rear pedal
- [8]Front pedal
- [9]rear brake pedal

## Chapter 2 Structure

This motorcycle mainly consists of riding system, operation system, brake system, transmission system, fuel supply system, electrical system and engine. Refer to Diagram 1-3.

Diagram 1-3 structure

- [1]Riding system
- [2]Electrical system
- [3]Operation and brake system
- [4]Fuel supply system
- [5]Engine
- [6]Transmission system

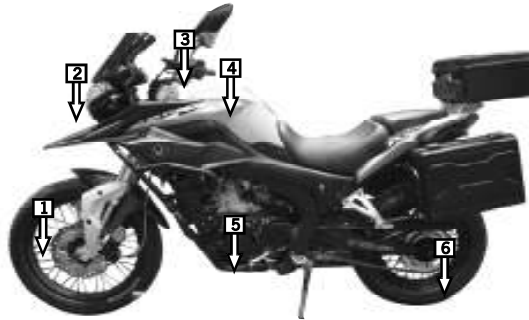

### 1 Riding System

The basic function of riding system:

[1]Make motorcycle in a whole and support whole motorcycle.  
[2]Receive the torque from transmission setup. Provide traction for motorcycle running through the contact of wheel and road.

[3]Endure and transmit road function and endure torque made by the outside force of wheel.

[4]Absorb and handle the strike and shake produced during motorcycle running.

Riding system mainly contains frame assembly, front/rear shock absorber, front/rear wheel and some other accessories.

### 2 Operation and Brake System

The main function of operation system is to control running direction, running speed, brake, illumination and signals, and to ensure motorcycle running safety.

The operation and brake system mainly consists of steering setup, brake setup and some relative controlling handlebar, controlling switch, steel cable and accessories.

### 3 Transmission System

The basic function of transmission system is to augment torque or reduce transmission speed according to the road condition and running need, After that, to transmit the result to drive wheel and to make motorcycle run.

Transmission system mainly consists of starting device, clutch, gearshift and accessories of rear transmission device.

#### [1]Starting Device

The function of starting device is to start engine and to make engine automatic running. The starting device of motorcycle is divided into two modes. One is kick starting, and the other is electric starting.

#### [2]Clutch

The function of clutch is to transmit or cut off the power from engine reliably and softly, and to ensure motorcycle to stable start and gearshift. The clutch of this motorcycle adopts automatic, wet and multiple.

#### [3]Gearshift

The function of gearshift is to change the rev and drive torque of motorcycle transmission and to ensure proper pull and speed of motorcycle, so that it can adapt the changable running condition. The gearshift of this motorcycle adopts gradational gearshift.

#### [4]Rear transmission device

The function of rear transmission device is to transmit the engine power to transmission device,so that the rev is reduced and the torque is augmented.Then transmit the power to rear wheel to drive motorcycle run.The transmission of this motorcycle is chain transmission.

#### [5]Intake and Exhaust System

The function of inlet system is to guide and filtrate air,to control the volume of mixed gas flowing into cylinder according to the needs of working condition.It mainly consists of inlet pipe and air cleaner.

The function of exhaust system is to vent the exhaust gas in cylinder and to reduce the noise during exhausting.It mainly consists of exhaust pipe and muffler.

#### [6]Fuel Supply System

The function of fuel-supplying system is to confect clean gas and air into mixed gas with proper proportion according to the working condition of engine,and to offer the mixed gas timely and quantitatively to burning chamber to keep burning.

The fuel supply system mainly consists of fuel tank,fuel pump,fuel injector,fuel filter and fuel pipe.

### 4 Electrical System

The function of electrical system is to offer electric power to the starting and running of motorcycle,and to send sound or light signals so that the running safety can be ensured.The electrical system mainly contains the part of electric power supply,electric power consumption and electric power control.

#### [1]Electric Supply

The part of electric supply mainly consists of generator and battery.When generator reaches a certain rev driven by engine,generator will export electric power,which not only offers the power to electric setup,but also to the battery so that it can be charged. The battery can transfer chemical power to electric power,which can support starting,illumination and signal setup.

#### [2]Electric Consumption

The function of electric consumption part is to offer several kinds of sound or light signals to ensure running safety,meanwhile it can start engine conveniently and fast.It mainly consists of illuminating signal device and electric starter device.

#### [3]Control Part

The function of control part is to ensure and adjust electric supply and electric consumption.It mainly consists of ECU,rectifier,starter relay,fuse, control switch and main wire.

### 5 Engine

Engine is a device,which is to make fuel burn in the cylinder and to transfer heat to mechanical power. it is the power producer of motorcycle.(the maintenance of engine please refer to the engine service manual)

## Chapter 2 Maintenance Knowledge

### Section 1 Attention Items of Maintenance

When there are some problems with motorcycle, you can have it repaired at Zongshen after-service station or professional maintenance station. Meanwhile you also can refer to this maintenance manual. Parts on the motorcycle will be worn or loose during riding. Lack of regular maintenance can affect the safety and reliability of your motorcycle and shorten the service life. So a regular maintenance will help to keep your new motorcycle operating at peak performance.

[1] When motorcycle is being repaired, please use the components, accessories, lube oil and other accessory materials which produced or recommended by our company or. If you use the components which are not suitable for this motorcycle, it will influence the motivity, reliability, stability and comfort of motorcycle. Seriously, the motorcycle will be destroyed.

[2] After disassembly and reinstallation, please replace new gasket, sealed components and open pin.

[3] When tightening bolts and nuts, you should do with the principle of diagonal crossover and completely tighten to the standard torque value during 2 or 3 times.

[4] When cleaning the components, please adopt non-burning cleaning fluid. Paint some lube oil on the moving parts of components before installation.

[5] After installation, check whether components are installed correctly. Check methods are circumrotate, movement, operation and inspection.

[6] When disassembling motorcycle, normally please use appropriate maintenance tools.

[7] Please repair motorcycle with flameout. If the motorcycle needs to be repaired while engine is working, please do it at a well ventilated place, because the exhaust gas from motorcycle contains poisonous CO.

[8] Gas is easy to burn or explode, so do not smoke or ignite at maintenance place.

[9] The electrolyte of battery consists of vitriol. If eyes, skin and clothes are spattered with electrolyte, completely clean it with water. Seriously, please go to hospital.

[10] There is hydric gas from battery, which is flammable and explosive, so do not smoke, ignite fire near battery. Especially when it is charging.

Statement in this manual preceded by the following words are of special significance:

 **WARNING**

► Indicates a potential hazardous situation, which if not avoid, may cause people hurt or death.

 **CAUTION**

► Indicates a potential hazardous situation, which if not avoid, may damage your bike.

 **ADVICE**

► Indicates special information to make maintenance easier or instructions clearer.

## Section 2 General knowledge of Maintenance

### 1 Classification of Maintenance

Maintenance can be divided into 4 parts according to the range and interval period. 4 parts contains major repair, medium repair, minor repair and assembly repair.

[1] Major repair is a thorough repair, which needs to make motorcycle completely disassembled, cleaned, measured, inspected, adjusted and so on. After the major repair, motorcycle can reach the standard of original motivity, economy, stability and safety performance.

[2] Medium repair is to repair and adjust some parts which influence the performance of motorcycle. Medium repair can eliminate potentially hazardous, avoid deterioration of problems and keep a good running condition.

[3] Minor repair is a running repair, which is mainly focus on elimination of some temporary problems or partial hurts during running.

[4] Assembly repair is a separate repair for assembly, which is caused when the requirement of a certain assembly or hurt, abrasion or distortion of a certain component influence the performance of motorcycle.

### 2 Repair Technics

#### (1) Disassembly of Motorcycle

Disassembly is a very important part during repair. The method of disassembly will directly influence the quality and efficiency of repair. If components broken or blocked caused by unproper disassembly, it will not only expand the repair range, but also will delay the repair period. Seriously, it will lead to the disassembly stop. The basic principle of disassembly is the order and direction opposite to those of installation. Normally, the order is from outside to inside, from up to down, from big to small. When disassembling, pay attention to the store environment and order to avoid damnification and confusion.

The order and method of disassembly is not absolute. Different motorcycle has different order and method of disassembly. You can refer to the following introduction of disassembly, installation and maintenance.

The basic principle of disassembly of Engine and other components is the same as principle of whole motorcycle. The order and method of disassembly is different because of different structure and characteristic of different component. Pay more attention to the store environment and order for all disassembled parts are components.

Pay attention to the following items when disassembling motorcycle and components:

[1] The components which have high requirement for position should check its position mark first when disassembling. If the mark is not clear, please re-make a mark.

[2] When dismantling the components which are too tight, please use the special tools. If you have none special tools, support the motorcycle with some wooden or soft metal, then hammer the right place with gluey hammer to avoid component damage.

[3] When dismantling the assembly of front/rear shock absorber and front/rear wheel, support motorcycle with main stand. Avoid motorcycle falling down to hurt people or damage the components.

[4] Put the components which are dismantled in order. Do not put those components directly on the ground. Such as spray components, chromeplate components and high precision components.

[5] The nuts and bolts which are dismantled should be stored carefully, which also can be installed on the original place, but don't tighten them.

[6] The components which are only dismantled by special tools, please operate as regulation. Please energize equally and pay attention to the direction.

[7] When dismantling components, please choose suitable tools, energize equally and pay attention to direction to avoid component damage.

[8] The brake pads which are dismantled should be stored separately, which are also forbidden to contact lubeoil, otherwise it will lead to brake failure.

[9] When there are some difficulties to dismantle because of the rust of screw thread components, you can dip the components in gas for several minutes, then dismantle them.

[10] When dismantling gaskets, you should be much careful to avoid damage.

#### (2) Cleaning of Components

After the components are dismantled, they must be adhibited some oil or carbon deposit. Clean them to help maintenance and installation. You can choose gas, coal oil and cleaning liquid to clean. The cleaning method is adopted according to the speciality of components.

##### [1] Oil Stain Cleaning

Cool cleaning and heat cleaning are two methods for metal parts. Use gasoline or coal oil as detergent, put the metal parts into detergent and scrub them by brush, which is called cool cleaning. Use aqueous alkali as detergent, put metal parts into detergent, heat up to 79°C~90°C and immerse for 10min~15min, then take out the metal parts and clean, which is called heat cleaning.

## [2] Carbon Deposit Removing

To remove the carbon deposit on component, we can use mechanical method or chemical method. Mechanical method is that scrape deposit with bamboo-scraper or spade and clean them with gasoline. Immerse the component, brush the carbon deposit off and clean them with hot water, which is called chemical method.

## (3) Parts Inspection

Inspect the parts after cleaning. The purpose for inspection is to check whether the parts need to be repaired or replaced. There are three methods, i.e. direct inspection, instrument inspection and troubleshooting.

### [1] Direct Inspection

Direct inspection is to check and judge the condition of parts by individual sensation instead of instrument. It is a simple and feasible method, which is widely used for maintenance.

### [2] Instrument Inspection

Instrument inspection is to measure the size and geometry shape of parts by gauge and apparatus; then compare the measured value with limiting value to figure out the condition of parts. This method can get an accurate judgement, but it needs careful inspection for the precision of instrument and reasonable selection of parts.

### [3] Troubleshooting

To find the latent fault of parts, we can apply troubleshooting. Usually we adopt the method of oil immersion and knock during maintenance. The process of this method is as following. First, immerse the parts into coal oil or diesel oil for several minutes. Second, take out and wipe the parts. Third, spread talcum powder on the surface of parts. Finally, knock the non-working surface of parts gently with a small hammer. In this way, the knock can produce vibration and oil that has remained in crack will splash for vibration. The splashed oil will dye the talcum powder yellow, so we can easily find a yellow mark in crack place.

Cleaning methods for non-metal parts differ in different materials. The best detergent for rubber parts is alcohol. Do not use coal oil or gasoline to clean rubber parts, because they can cause inflation and deformity of rubber parts. Gasoline is suitable for clutch disc and brake pads friction disc, while aqueous alkali is forbidden.

## (4) Repair methods and skills

After disassembly, cleaning and inspection, the following is the principal stage. Mastering the basic skill well is the key to ensure a good quality of maintenance. The skills for maintenance are as following:

### [1] Chiseling, filing and scraping

Chiseling is to process metal parts by hammer and chisel. The functions are cutting and parting.

Filing is to rasp off the surface of parts by a file. It includes rasp and delicate filing. Teeth of a file directly decide the roughness degree when filing metal parts. The operation of file is different because of different shape surface of parts.

Scraping is a process which scrapes off a thin layer from the surface of parts. It is a delicate work, so we should scrape the parts bit by bit with great care. Usually, scraping off 0.005~0.01mm each time. Before scraping, we need to spread red lead on the surface of parts. Then, match the parts with standard one. The unmatched parts are the aim of scraping. After several match and scraping, the contact surface of parts is bigger. So it reaches the requirement and achieves the purpose.

### [2] Rubbing

Rubbing is to rub out a thin layer from the surface of parts by grinder and crocus. This is a fine finish for the surface of parts, which can provide a precise size, exact geometrical shape and the lowest degree of roughness. It includes flat rubbing, internal rubbing and external rubbing. The rubbing tool for flat rubbing is a plane plate, while internal rubbing tool is a pestle. During maintenance, rubbing methods are usually used for rubbing the flat of crankcase and internal hole of connecting rod.

### [3] Rivet joint and welding

Rivet joint is a process which can join two parts or more together with rivets. It is widely used in maintenance, such as rivet joint of clutch disc and so on. Classified by its function, rivet joint can be divided into fixed rivet joint, active rivet joint and seal rivet joint.

Welding is a process which can bring into close union of two metal parts with welding tool and solder. It is also widely used in maintenance, such as repairing the crack of frame and other metal parts.

### [4] Drilling and Reaming

Drilling is a process which drills holes on parts or materials with drill bit. The drilling tools mainly include beam drill, bench drill, electric hand drill, rotary hand drill, drill bit and clamp.

Reaming is a fine finish by reamer, which can increase the precision degree of holes on parts and decrease the roughness degree. It improves the match precision between hole and shaft and the precision can reach grade 6 to grade 8. The basic tool for reaming is a reamer, such as fixed reamer, adjustable reamer, conical reamer and so on. Before reaming, we need to drill a bottom hole in advance, which is for the precision requirement of hole shaped and making room for reaming procedure.

[5] Tapping and thread die cutting

Tapping is to process internal thread with screw tap and thread die cutting is to process external thread with threading die. The essential tools for tapping is screw tap. Generally, screw tap consist of master tap and plug tap. The difference between these Two kinds of tap is that master tap adopt a slight bevel angle on cutting part, instead, plug tap adopt a steeply bevel angle. After tapping, we should drill a bottom hole with chamfer.

Please refer to the specialized list or the following formula for the bit diameter of bottom hole :

Diameter of drilling hole outside diameter of screw thread - 1.1mm  $\times$  screw pitch (appropriate for iron and copper)

Diameter of drilling hole outside diameter of screw thread - 1.2mm  $\times$  screw pitch (appropriate for steel and brass)

When cutting inside threads, turn master tap into the chamfer-angle hole, then take out and use plug tap to shape the threads.

The tool for outside screw threads cutting is screw plate. Screw plate includes fixed screw plate, adjustable screw plate and active screw plate. Usually, we use fixed screw plate, i.e. round screw plate. When cutting outside screw threads, choose screw plate and diameter of club-shaped material according the required material, diameter of screw thread and screw pitch. To make proper choice, please refer to the specialized list or the following formula:

Diameter of club shaped material outside diameter of screw thread - 0.13mm  $\times$  screw pitch

Bevel the end of club-shaped material in 15° ~ 20° angle before cutting outside screw threads. To ensure easy operation, the screw plate and club-shaped material should be in vertical, therefore, the minimum diameter of cone angle should less than inside diameter of screw thread.

[6] Rectification

The operation that eliminates the unevenness of plane-shaped, bar-shaped and column-shaped parts is called rectification. Rectification can reshape the parts.

The rectification depends on the flexibility of metal parts. Therefore, metal parts with good flexibility can be rectified directly, such as soft steel and red cooper ' metal parts with less flexibility need to anneal before rectification.

The factors for rectification are torsion, extension, bending and expansion.

[7] Bonding

Bonding is widely used in manufacture and repairs because it operates easily and can be done without special equipment and expensive materials. In addition, the bonding parts don't need to be processed by high precision machine, such as the bonding of handlebar and steering head, bonding of plastic label and spray-paint metal parts, bonding of brake disc and brake pads. There are various adhesive, such as epoxy adhesive, phenol formaldehyde adhesive and so on.

### (5) Motorcycle assembly

The last procedure in repair is assembly, which is a key to ensure the good quality of motorcycle.

[1] Assembly includes module assembly, parts assembly and overall assembly. In the process of assembly, we should abide by the principle that assemble module first, then parts and the overall finally. The sequence of assembly is opposite to disassembly, which is to first assemble the last disassembled components, and to last assemble the first disassembled components.

[2] Module assembly is the first stage in whole process, which makes the parts into a single module, such as the combination of front brake drum cover, the combination of brake pads, the combination of wheel.

[3] Parts assembly is based upon module assembly, which assembles the parts and module as a whole, such as front and rear wheel assembly, front fork assembly, shock absorber assembly and so on.

[4] Overall assembly is the last procedure to complete the whole working process, which connects parts and modules with frame according to installation sequence by all means.

[5] The sequences of overall assembly are similar. The operation is as following: Firstly, finish all modules assembly and parts assembly, then install engine assembly and gearbox assembly on frame. Secondly, install front fork assembly, handlebar assembly, front and rear fender assembly, shock absorber assembly, carrier assembly, front and rear wheel assembly, fuel tank assembly and seat assembly. Thirdly, install headlight, taillight, steering indicator, horn and battery assembly. The fourth, connect all electric circuit and control cables. The fifth, install driving chain, dentiform belt, wind shield and chain cover or belt cover. Last, lubricate the whole motorcycle.

[6] Consult the following reference about disassembly, installation and inspection if there is any assembly sequence difference which is caused by different type and structure.

[7] Pay attention to the following:

Choose a clean and wide place; strictly follow the assembly requirements; parts connecting should accord with specification; avoid misfitting and leaving out of any gaskets, cotter pin and fixing clip.

### 3 Adjustment after Repair

The interconnection of parts have been affected in some extent after repair. To recover the performance of motorcycle, adjust them according to the specification of user's manual. adjust as follows:

### (1) Ignition Time Adjustment

If there is a wrong ignition advance angle, it will cause a series of problems, such as hard engine starting, power decrease, high fuel consumption, engine overheating, uncomplete fuel burning, exhaust valve overrun, short service lifetime and so on. Therefore, adjust ignition advance angle firstly.

If ignition system cannot work well, check electrical ignition device, high voltage coil, ignition coil and triggering loop of magneto and so on.

### (2) Carburetor Adjustment

Carburetor adjustment is very important, which directly decides the performance of engine, so maintain it as the following:

Before carburetor adjustment, make sure the operation temperature of engine is in order, open choke valve, check whether the valve clearance and ignition timing are right, and ensure no leakage or block of engine and carburetor. Carburetor adjustment includes idle adjustment and fluid level adjustment of float chamber. The adjustment can make the operation of engine idle stabler and avoid poor or rich oil in carburetor.

### (3) Clutch Adjustment

Clutch is used to transfer power, so it plays an important role in transmission system. Adjust the free stroke of clutch operation grip within 10mm and 20mm. For some motorcycles, there is a need to adjust adjusting bolts of disengagement parts.

## Section 3 Adjusting Data of Maintenance

Table 2-1

operation/ brake/ shock absorber/wheel

items		Standard Value (mm)	limit Value (mm)
Free stroke of front brake lever		10~20	20~30
Free stroke of rear brake pedal		20~30	30~40
Free stroke of throttle control grip		2~6	10~12
Depth of flower pattern on tire surface		4.0	2.0
Stroke of front shock absorber		130	————
Free length of front shock absorber spring		425	————
Stroke of rear shock absorber		45	————
Free length of rear shock absorber spring		235	————
Wheel hub runout	axial	——	0.8
	radial	——	0.8
Axle runout	front	——	0.8
	rear	——	0.8



Table 2-2 Maintenance Cycle

Items	Times	Items Period	Mileage km			
			1000km	4000km	8000km	12000km
●	Fuel system			I	I	I
●	Fuel filter		A	R/I	R/I	R/I
●	Control system		I	I	I	I
●	Choke valve cable		I	I	I	I
	Air cleaner element		A/R	R	R	R
	spark plug gap		I	I	I	I
●●	Valve clearance		I	I	I	I
	Driving chain		I/L	I/L	I/L	I/L
	Battery		I	I	I	I
	Abrasion of brake pads		I	I	I	I
	Brake system		I	I	I	I
●	Brake light switch		I	I	I	I
●	Headlight adjusting		I	I	I	I
	Main/side stand		I	I	I	I
●●	Front/Rear shock absorber		I	I	I	I
●	nut/bolt/fixing components		I	I	I	I
	Outer tire of front and rear wheel		I	I	I	I
●●	steering system bearing		I	I	I	I

Maintain the motorcycle according to the period that is listed above. Each capital letter on the list stands for as follows:

R-clean, A-inspect, L-lubricate, I-inspect, clean, adjust, lubricate or replace

● indicates that maintaining this item by service center of our company. If maintain it by yourself, please consult this maintenance manual.

●● indicates that maintaining this item only by service center of our company. To ensure riding safety, please follow our advice.

 **CAUTION**

► Shorten the maintenance period if motorcycle usually runs in dusty region.

table 2-3 Torque tightening

	Items	Specification	Torque Value(N.m)
Motorcycle	Locknut of main pipe	M24×1	25~35
	Fixed bolt of handlebar	M10×1.25	50~60
	Front axle nut	M14×1.5	70~80
	Rear axle nut	M14×1.5	70~80
	Engine suspension bolt	M10×1.25	45~55
	Fixed nut of rear shock absorber	M10	45~55
	Locknut of chain wheel	M8	28~32
	Nut of rear rocker arm	M12×1.25	50~60
	fork shaft nut	M12×1.25	55~65
	fork shaft nut	M10×1.25	45~5

## Section 1 Fuel Supply System

Fuel supply system consists of fuel tank, fuel pump, injector, fuel filter and oil pipe.

### 1 The Structure and Working Principle of Fuel System

#### [1] Fuel Tank

Fuel tank is jointed by the armor plate which is normally 0.8mm~1.0mm. Some fuel tank is jointed apertured clapboard inside, which not only strengthens the fuel tank, but also avoids the fuel gurgitation during riding. Because of the strong erosion of oil, it must be galvanized on the surface of fuel tank. There is a fuel-adding hole on the top of fuel tank and close the fuel cap which has air hole, so that it can avoid fuel leakage during riding and ensure the balanced pressure of inner and outer fuel tank. So that fuel can flow out naturally.

#### [2] Fuel Pump

The fuel pump consists of pump, support and oil pressure adjuster. Flexible installation can decrease the vibration on the fuel pump. The pump installed in the fuel tank is to get a simple construction and non-leakage.

The pump adopts turbo, single stage and electric type. It is driven by a DC motor with 12V and controlled by ECU through the pump relay. There is a one-way valve at the exit of the pump which can prevent the oil from flowing back to the tank when engine stops and ensures a good starting performance.

#### [3] Fuel Injector

Fuel injector injects the proper amount of atomized fuel into the intake pipe of engine by ECU, thus the atomized fuel can participate in the combustion process in the cylinder.

#### [4] Fuel Filter

Fuel filter connects with the oil way between the electric fuel pump and fuel rail. This system adopts the dedicated filter for EFI to make impurities not block the nozzle. The housing of filter has enough intensity and it never break due to the fuel pressure.

#### [5] Fuel Pipe

The pressure of the fuel supply system is 250kPa. Its selection must have enough safety factor for security.



## 2 Disassembly and Maintenance of Fuel System

[1]The capacity of the fuel tank is 16L.  
When refueling, please keep air circulation and keep away from sparks and flame.

### Warning

- ▶ Fuel is highly combustible. Smoking and getting close to the fire are strictly forbidden
- ▶ Switch off the motorcycle and operate in an airy place.



[2]Check the fuel tank cap for fuel leakage. Replace the sealing ring of cap if necessary.

### WARNING

- ▶ The brand of oil allowed is 93#. Do not using other type of oil.



[3]Check the fuel tank for fuel leakage. Replace or repair it if necessary.

### CAUTION

- ▶ If the fuel tank is deformed by the collision of external force, repair it to original condition with wooden hammer. If the fuel tank has cracks, replace the fuel tank without repair.



[4]Check the fuel pipe for fuel leakage or aging. Check filter for block, repair or replace it if blocked.

### CAUTION

- ▶ If the fuel pipe has fuel leakage or aging, replace it.
- ▶ Before replacing the fuel pipe or filter, Shut up ignition switch to stop the fuel pump and avoid the fuel flow out of the fuel tank.

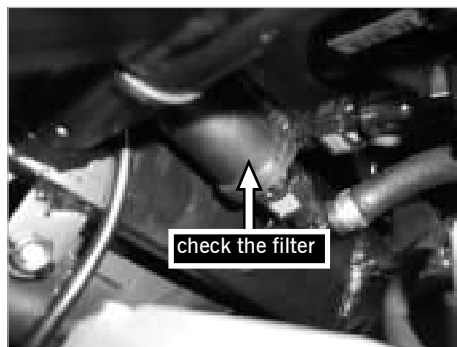



[5] First of all, dismantle the left and right side cover and seat. Then remove fixed bolt and take out the fuel tank.

**⚠ WARNING**

► Keep the oil away from fire when dumping the oil.

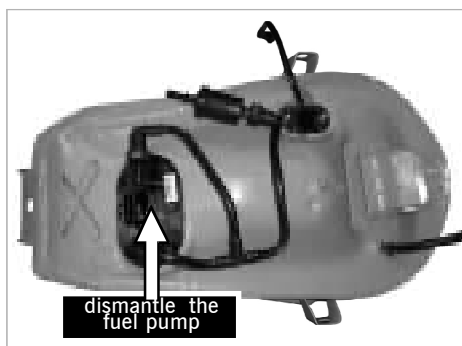

[6] Remove the six fixed bolt (M5 × 16) of fuel pump by hexagon wrench.

**⚠ WARNING**

► Please dump oil first and keep away from the fire when dismantling the pump.

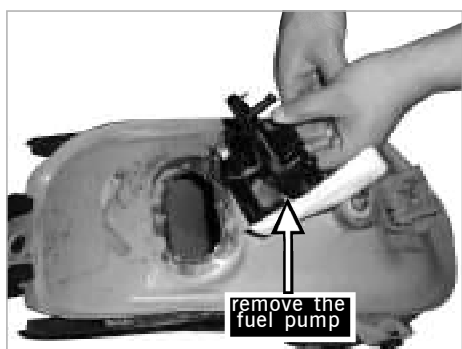

[7] Take out the pump, and then clean the oil sludge and water in the tank with oil sludge.

**⚠ CAUTION**

► After cleaning, the fuel tank could be used when drying out.

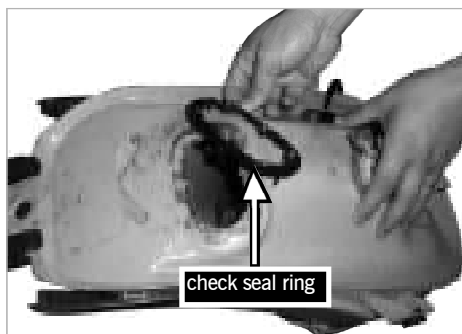

[8] Check the pump seal ring for aging, breaking or oil leakage. Replace it if necessary.

[9]Check the motor of fuel pump for running.And clean or replace the fuel strainer.

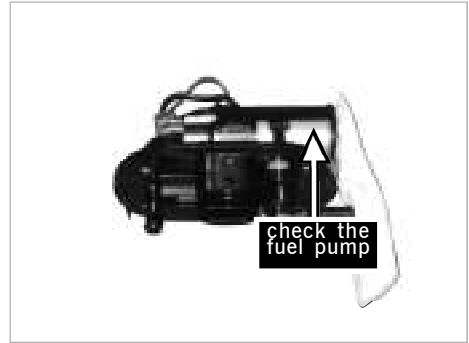

**▲ ADVICE**

► Replace the fuel filter when the motorcycle drives about 8000~10000Km.

### 3 The cause, trouble description and repair method of fuel supply system

Table 4-1 Maintenance of Fuel Supply System

component description	cause	trouble description of component	trouble description of motorcycle	repair method
fuel tank	Fuel tank body is broken.	leakage of fuel tank	—————	Repair or replace fuel tank.
	The venthole of fuel tank cap is blocked.	Fuel supply is not good.	Motorcycle cannot start.	Unblock the venthole of fuel tank cap.
	Fuel tank is deformed.	Fuel tank is accidented.	The appearance of motorcycle is bad.	Repair or replace fuel tank.
fuel pump	oil-filter screen is dirty or small holes are blocked.	Fuel supply is not good.	Motorcycle is hard to be started or cannot be started. The engine power is not enough and the idle speed is not stable.	Clean oil-filter screen.
	The fuel pump body is blocked.	Fuel supply is not good.	Motorcycle cannot be started.	Clean or replace fuel pump.
	The motor of fuel pump does not run	Fuel cannot be supplied.	Motorcycle cannot be started.	Replace the motor.
	Fuel pressure regulator is blocked.	Fuel can not be back.	Oil duct is cracked	Clean or replace the pump assembly.
Fuel pressure regulator is normally open.	The pressure of oil supply is low.	Motorcycle is hard to be started or cannot be started. The engine power is not enough and the idle speed is not stable.		

## Section 2 EFI system

The main effect of EFI system is to convert the fuel which is supplied from fuel tank into a mist, then mixture of the mist and air import into the combustion chamber.

### 1 The Structure and Working Principle of EFI system

EFI system consists of ECU, nozzle, throttle valve, intake air temperature, integrated pressure sensor, engine temperature sensor, ignition coil, CKP, fuel pump, oxygen sensor.

EFI system could control the ratio of fuel-air mixture which import into the engine cylinder, combustion process and exhaust gas conversion accurately. So as to optimize engine performance and driveability, and control the exhaust emission strictly.

ECU is a microprocessor as a core of SCM. By sensor and working request switch installed in the engine and body of motorcycle, ECM could analyse mode of operation and estimate operating conditions. Finally, controlling engine and relevant mechanisms accurately through actuator in the engine and body of motorcycle.

The type of engine speed and crankshaft angle sensor is magnetolectricity. The function of this sensor is to determine the position of the rotating and revolving speed for crankshaft.

Crankshaft angle sensor is installed on the clutch housing and it works with 24x gear ring from flywheel.

MAP sensor is installed in the intake manifold to measure the pressure, so ECU could judge air enter into the engine from this signal.

MAP sensor consists of an elastic diaphragm seal and a magnetic core. Diaphragm seal and magnetic core is placed in the coil accurately. When they sense pressure, they could produce a 0~5v output signal in direct proportion to input pressure.

Throttle position sensor is installed on the throttle body and has a same axle with throttle lever and throttle valve. The structure is a linear variable resistor and its sliding terminal is driven by throttle axle.

Resistance signal, which is passed to the ECU through this sensor, depends on the opening of throttle. EFI could judge the real-time load of engine and dynamic variation according to the signal and its rate of changes which output from the sensor.

Sensor of intake air temperature is installed on the pipe of intake system. The function of it is to test air temperature enter into the engine. It also use thermistor of NTC coefficient as a sensing element.

The change of gas temperature directly affects its density fluctuation, therefore, intake air temperature is one of the importance parameters for computing actual amount of air, which enters into the cylinder.

Nozzle is an electromagnetic switch device. Two poles elicit from coil connect with ECU through engine wires. Voltage is applied to coil under the control of ECU, and the coil produces magnetic force to overcome spring force, fuel pressures and a vacuum suction of intake manifold, suck up iron core, that could enables fuel to traverse the seal surface of ball valve which is the one with the iron core, then the fuel sprays from nozzle and forms a mist spray; After interruption of power supply, magnetic disappears and nozzle shuts.

The top of fuel injector adopts rubber sealing for forming a reliable leakproofness of fuel pressure with the port of fuel channel; The bottom of it adopts rubber sealing for forming a aeseal with engine intake manifold. Nozzle spray the fuel as mist into the inlet valve.

Throttle body is installed in the front of the intake manifold. It consists of valve body, throttle position sensor and ISCV. The main function is to control air inflow when engine is working.

Oxygen sensor is installed on the exhaust pipe of engine. It is a important part of closed-loop fuel control system.

The main sensitive materials of oxygen sensor is zirconia. Zirconia is heated to 300°C by exhaust and is activated, then oxygen ion traverses the zirconia part and gets to its external electrode. Ultimately, zirconia part induct content of oxygen from engine exhaust emission and change the output voltage value.

Oxygen sensor adopts Teflon insulated wires and stainless steel materials of component. Air for reference is imported through wire, so it is non-blocking.

When AFR becomes thin, oxygen content of exhaust increases and the output voltage of oxygen sensor reduces; Otherwise, the output voltage valve rises, it provide feedback of the real-time condition of AFR to ECU.

## 2 Disassembly and Maintenance of EFI system

The EFI of motorcycle has been calibrated before leaving the factory. When EFI system has failure, adjust idle screw of throttle voluntarily and replace or adjust parts of EFI are strictly prohibited. Please go to our service station to maintain for any queries.

EFI failure indicator is equipped in the meter. When ignition system is opened, the indicator lights up. When the indicator does not light up, that means there is failure. When engine starts, the indicator puts out. When the indicator keeps the light on or flashing, that means there is failure.

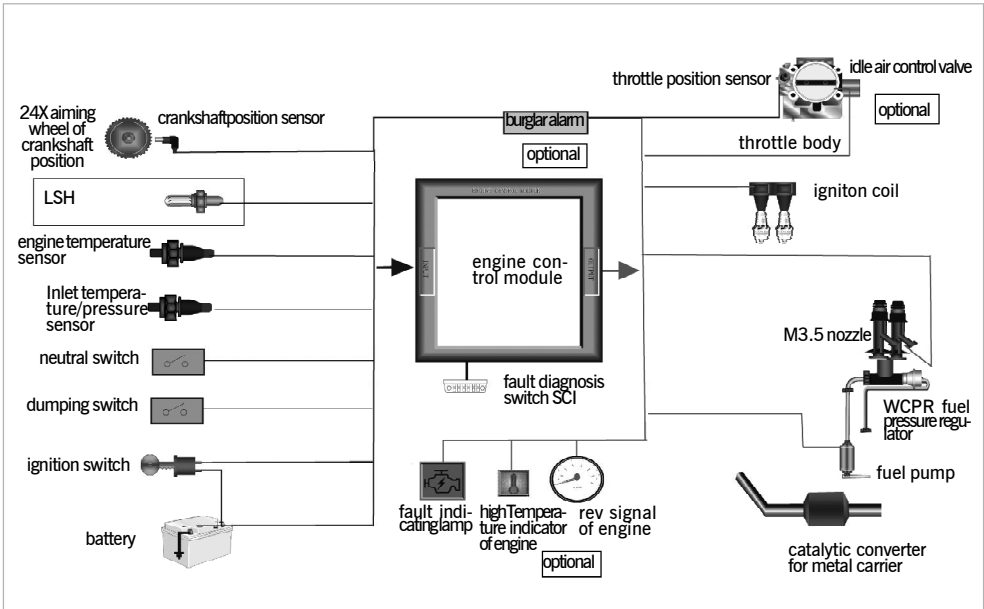

Structural drawing of EFI system

## 3 The trouble description of EFI system

Check the EFI system by the test instrument. If it has fault, replace homologous component of EFI. If not, please check the system as following:

1. Check the line connection;
2. Check whether or not the voltage reaches 9V.
3. Check the vehicle and EFI safe system
4. Check whether the oil-ways are blocked, extruded or broken.

## Section 3 Inlet and Exhaust System

The inlet system of engine mainly consists of air cleaner and inlet pipe. The main function of which is to guide and filtrate air, reduce inlet noise and control the volume of mixed gas which is going to engine.

The exhaust system mainly consists of exhaust pipe and muffler. The main function of which is to transfer the exhaust gas to atmosphere, reduce the noise when exhausting and the temperature of exhaust gas and eliminate the spark in exhaust gas. A good exhaust system can advance the inlet and exhaust system, increase engine power and reduce the fuel consumption, so it is also called exhaust muffler.

### 1 The Structure of Inlet System

#### [1] The Structure and Working Principle of Air Cleaner

Air cleaner is the important component of inlet system. The function of which is to filtrate, purify the air entering into cylinder, avoid dust, sand entering into cylinder so that it will reduce the abrasion of cylinder, piston and piston ring. Its performance has a big effect on the motivity of engine, noise of inlet and service lifetime. Experiences indicate the abrasion of cylinder will increase 8 times, the abrasion of piston will increase 3 times and the abrasion of piston ring will increase 9 times if air cleaner is not installed. In this way, the reliability of engine will reduce and the service lifetime will be shortened. Therefore, motorcycle must be installed with air cleaner. The requirement of air cleaner is not only to filtrate the air, but also the resistance of air flowing must be small so that the volume of engine inlet will enhance. More requirements are reliable working performance, simple structure, small dimension of appearance, light body and easy to maintain. The air cleaner mainly consists of element and sealed box. When engine runs, air will enter into the front cavity of air cleaner through air pipe, then flow into the rear cavity after filtration, and finally enter the throttle.

#### [2] The Structure and Working Principle of Inlet Pipe

Inlet pipe is the important component to connect throttle and engine inlet. Meanwhile, it has a function of supporting throttle and has a simple structure. Its bending shape depends on the position which the throttle should be corresponding to the engine inlet, but you should think about the influence of inlet resistance. If the pipe is long, it has an advantage of fuel pulverization, but air resistance is big. If the pipe is short, which is not good for fuel pulverization, but air resistance is small.

The mixed gas after pulverization of throttle flows into cylinder through inlet pipe and engine inlet. The inlet pipe reduces the heat which engine has transferred to throttle and separates the shake of engine from throttle.

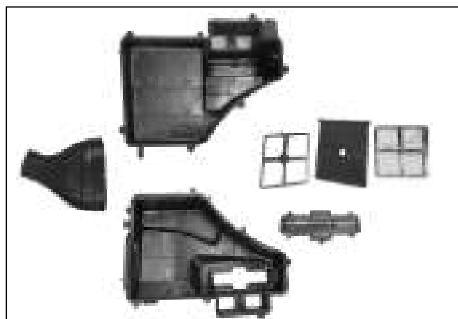

### 2 The Structure and Working Principle of Exhaust System

The exhaust pipe in exhaust muffler is made of bending steel pipe. It locates between exhaust vent of engine and muffler. Its function is to guide the exhaust gas from engine to the muffler.

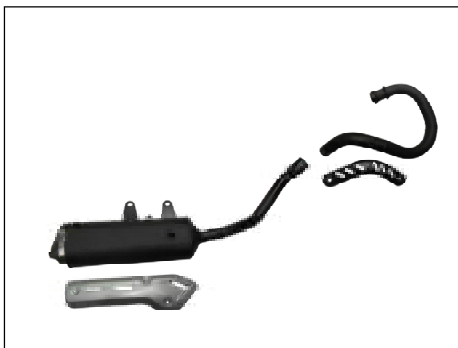



### 3 Disassembly and Maintenance of Intake System

[1] Dismantle suspension bolt of air cleaner and clamp screw of inlet pipe. Remove air cleaner assembly.

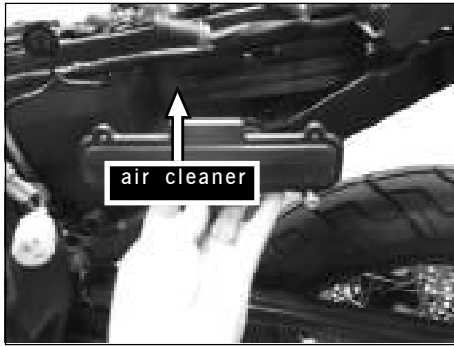

[2] Dismantle lock screw of air cleaner element. Take out the element of air cleaner and check whether there is too much dust on it. Clean it if too much dust.

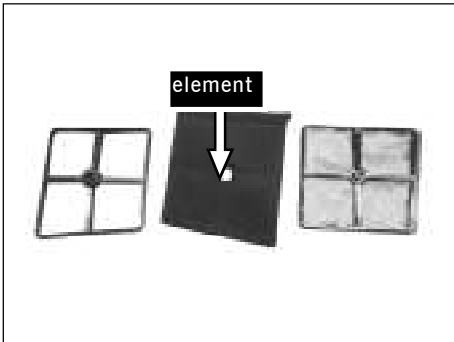

[3] Remove filter sieve of air cleaner and check whether it is damaged or dusty. Clean the filter sieve.

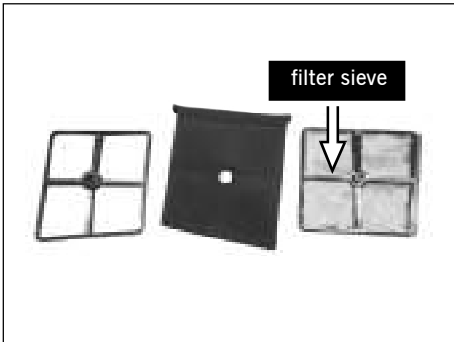

#### 4 Disassembly and Maintenance of Exhaust System

[1] Dismantle the locknut of exhaust pipe of muffler and suspension bolt of muffler. Check whether the suspension bracket is broken. Re-joint it if broken.

#### CAUTION

► When the suspension bracket of muffler is broken, replace or re-joint it.

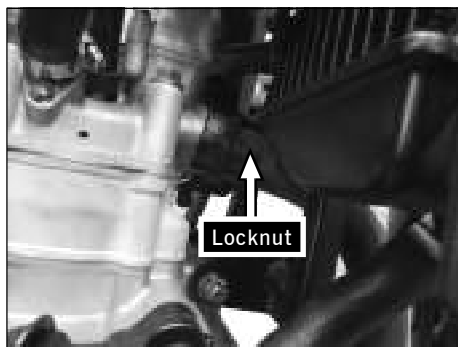

[2] Remove muffler and check whether the muffler is broken or damaged. Re-joint or replace it when broken or damaged.

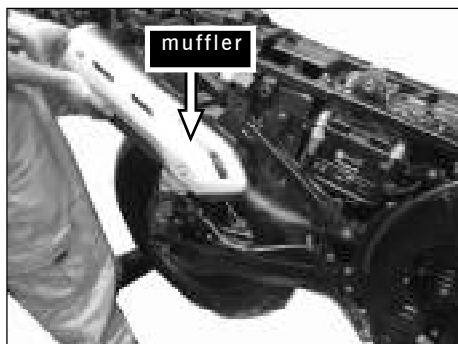

[3] Remove the seal gasket of muffler and check whether the gasket is damaged. Replace it if damaged.

#### CAUTION

► The seal gasket must be replaced every disassembly of muffler.



[4] Check whether there is carbon deposit in the muffler pipe. Clean it.

#### CAUTION

► Check Whether muffler is rusty or broken. Replace or maintain it if necessary.



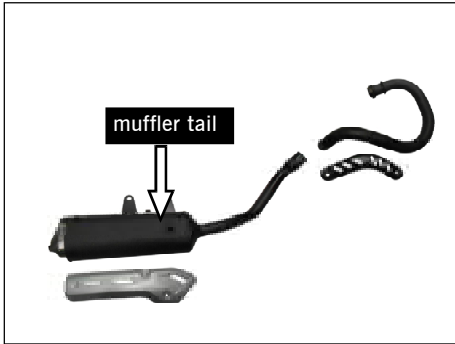

[5]Check whether there is carbon deposit at the muffler tail.Clean it.

## 5 The cause,trouble description and repair method of inlet and exhaust system

Table4-3 Maintenance of Inlet and Exhaust System

component description	cause	trouble description of component	description of motorcycle	repair method
inlet system	Element is dusty.	_____	Engine is hard to be started or cannot be started,poor engine power,unstable idle speed,high fuel consumption and black smoke from exhaust muffler.	Clean or replace element.
	The body of air cleaner is broken.	_____	The noise of engine inlet is big.	Replace air cleaner body.
exhaust system	leakage at vent of exhaust pipe	_____	The noise of engine exhaust becomes louder.	Replace seal gasket of exhaust pipe.
	The body of exhaust muffler is broken.	_____	The noise of engine exhaust becomes louder.	Replace exhaust muffler.

## Section 4 Rear Transmission Device

Because the export torque of engine is small and its rev is fast, it only can enhance the torque of engine to ensure the good working condition of motorcycle by 3-time deceleration. The first time is through the drive and driven gear of clutch. The second time is through the drive and driven bearing of derailleur. The third time is through the drive and driven gear of rear transmission device, so that the export power and rev of engine can economically and properly be used.

### 1 The Structure and Working Principle of Rear Transmission Device

The rear transmission device of this motorcycle adopts chain. It mainly consists of drive gear, driven gear, drive chain, chain tie-in, drive chain box, chain adjuster and rubber dead block.

First, it exports power through the end of countershaft of engine derailleur (power-exporting bearing), then transfers the power to driven chain through drive chain and makes 3-time deceleration. The driven chain is fastened on the cushion body by bolts. The cushion body connects with rear hub through rubber dead block. So when changing the speed during running, power is transferred flexibly through rubber cushion, so it avoids the abrasion of parts and enhances the comfort and stability of motorcycle.

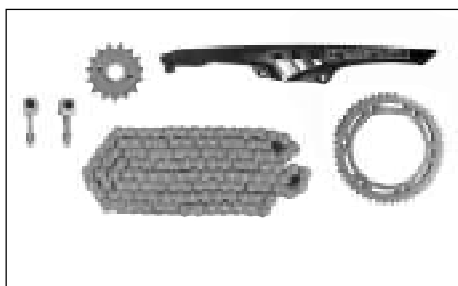

### 2 Disassembly and Maintenance of Rear Transmission Device

[1] Dismantle the fixed bolt of gearshift pedal and remove the gearshift pedal.



[2] Dismantle bolts of left rear cover of left crankcase and remove left rear cover of left crankcase.



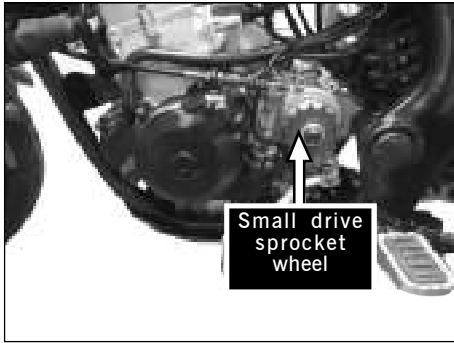

[3] Check the abrasion of small drive chain and replace the chain assembly if necessary.

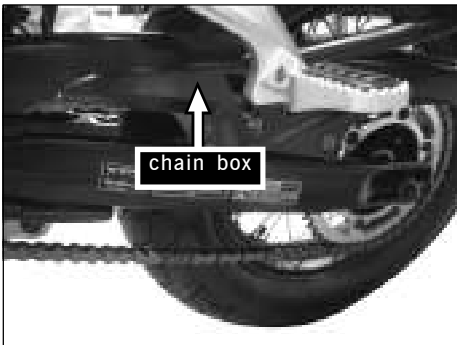

[4] Dismantle fixed bolt of chain box, and remove the chain box.

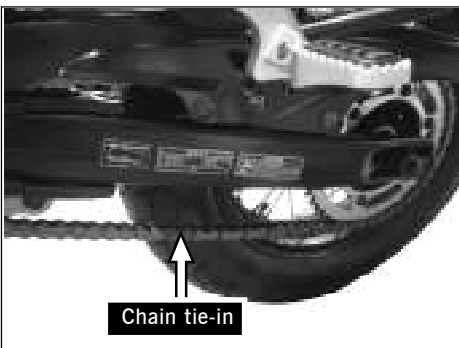

[5] Dismantle the spring clamp of drive chain. Remove tie-in of drive chain and drive chain. Check the abrasion of the tie-in of drive chain and replace it if necessary.

**⚠ CAUTION**

▶ When installing, the open end of spring clamp of chain tie-in should be opposite to the running direction of chain.

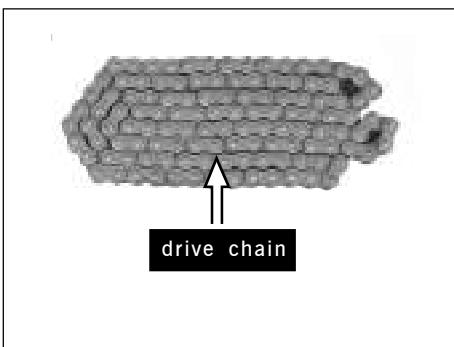

[6] Check the abrasion and distortion of drive chain. Wholly replace the big and small sprocket wheel and drive chain if necessary.

[7] Remove left gasket of rear wheel and check its abrasion. Dismantle the locknut of rear axle, then take rear wheel off.



[8] Remove the oil seal of cushion body of rear drive sprocket wheel and check its abrasion.



[9] Remove the rear drive sprocket and check it for wear.

 **CAUTION**

► When both big and small drive sprocket wheel are worn, wholly replace them, including big and small drive sprocket and drive chain.

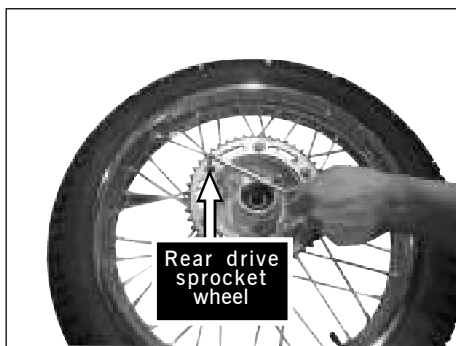

[10] Remove the gasket of rear drive sprocket wheel and check the abrasion of rear drive sprocket wheel axle. Replace it if necessary, otherwise it will influence the working of transmission system.

 **WARNING**

► When rear drive sprocket wheel axle is worn, replace it in time, otherwise it will lead to a big swing of rear wheel and a dead rear wheel.

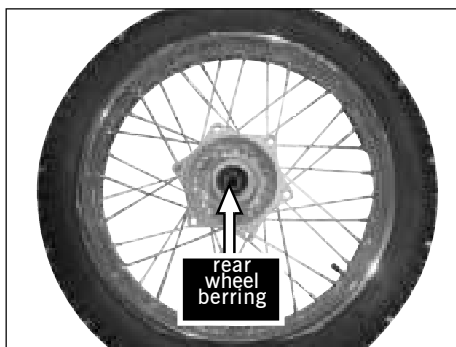

### 3 The cause, trouble description and repair method of rear transmission device

Table 4-4 Maintenance of Rear Transmission Device

component description	cause	trouble description of component	trouble description of motorcycle	repair method
drive sprocket wheel	Gear teeth are worn.	Drive chain disengages from gear.	Drive chain has strange sound and is easy to break off.	Wholly replace drive and driven sprocket wheel and drive chain.
	The inner teeth of gear are worn.	strange sound from drive chain	Drive chain is easy to break off.	Wholly replace drive and driven sprocket wheel and drive chain.
driven sprocket wheel	Gear teeth are worn.	Drive chain disengages from gear.	Drive chain has strange sound and is easy to break off.	Wholly replace drive and driven sprocket wheel and drive chain.
	The inner teeth of gear are worn.	strange sound from drive chain	Drive chain is easy to break off.	Wholly replace drive and driven sprocket wheel and drive chain.
drive chain	Drive chain is too dirty or has bad lubrication.	—————	Drive chain has strange sound.	Clean and lubricate chain.
	Drive chain is too tight.	improper tightening adjustment of chain	Drive chain has strange sound.	Adjust the tightness of drive chain to 15mm~25mm
	Drive chain is too loose.	improper tightening adjustment of chain	Drive chain has strange sound or is easy to break off.	Adjust the tightness of drive chain to 15mm~25mm
	Chain is worn.	Drive chain disengages from gear.	Drive chain is easy to break off.	Wholly replace drive and driven sprocket wheel and drive chain.
drive chain box	Drive chain box is damaged.	—————	sound from drive chain box	Replace drive chain box.
adjuster	improper adjustment of left and right adjuster	Rear wheel inclines.	Drive chain is easy to break off.	Readjust left and right adjuster and keep the left mark the same as the right mark.
	Adjuster is damaged.	Adjuster cannot be adjusted.	Drive chain is easy to break off.	Replace adjuster.
rubber cushion	Rubber cushion is worn.	Rubber cushion is damaged.	strange sound from rear wheel	Replace rubber cushion.

## Section 5 Frame and Accessories

Frame is the supporting framework of motorcycle. It is the main supporting part of motorcycle. Because motorcycle should bear mighty shake during running, its component and structure must have high intensity and the frame is required to be light. In this way, it is good for motorcycle to have a high-speed running.

### 1 Structure and Working Principle of Frame and Accessories



The frame of this motorcycle adopts pipe jointing and crooked girder. It has high intensity, good firmness and good suitability. It mainly consists of head pipe, main frame, tail pipe, rear supporting pipe and low bending pipe. It is made through the methods of jointing, riveting and so on.

Frame is used to support engine, transmission system, operation system, seat, fuel tank, brake system and so on. Meanwhile, it also offers the installing point for other accessories. It makes motorcycle as an integrated part.

### 2 Disassembly and Maintenance of Frame and Accessories

[1] Check rearview mirror for looseness and damage. Fasten or repair it if loose or damaged.

#### CAUTION

► Keep the rearview mirror clean and dustless. Adjust it to its best angle before riding.

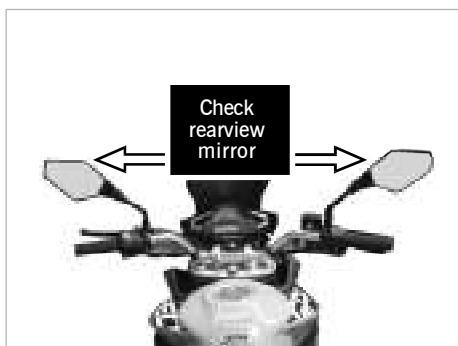

[2] Check whether side stand is bent or distorted. Repair or replace it if bent or distorted.

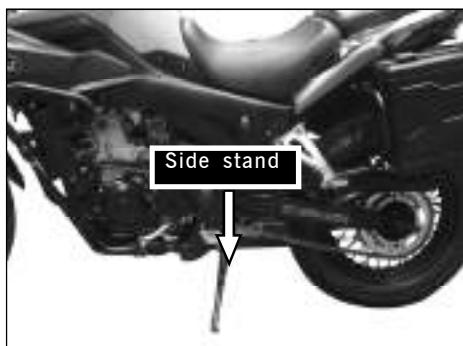



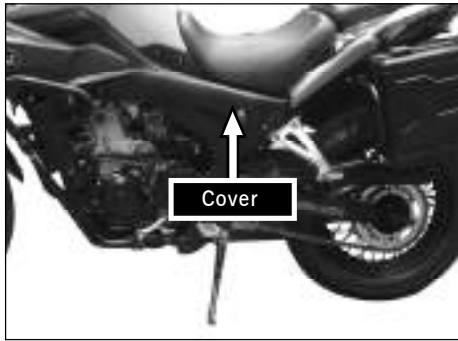

[3]Check all the covers of motorcycle. Replace them if damaged.

 **ADVICE**

► Replace the covers if damaged.

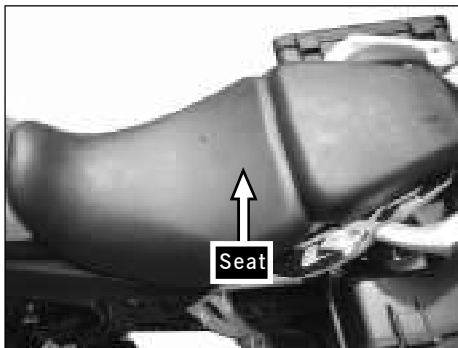

[4]Check whether the seat is damaged. Replace it if damaged.

 **ADVICE**

► Replace seat if damaged.

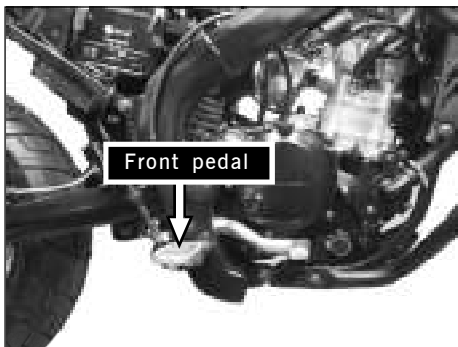

[5]Check whether the rubber cover of front pedal is damaged. Replace it if damaged.

 **ADVICE**

► Replace rubber cover of front pedal if damaged.

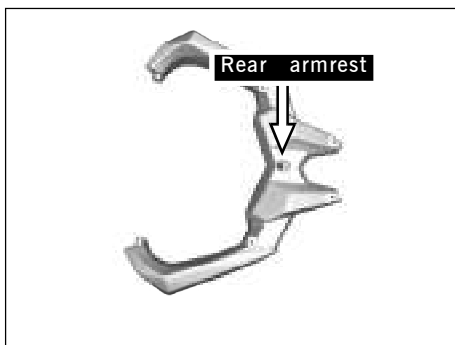

[6]Check whether rear armrest is broken. Replace or repair them if is.

 **ADVICE**

► Replace rear armrest if it parts.

### 3 The cause, trouble description and repair method of frame and accessories

Table4-5 Maintenance of Frame and Accessories

component description	cause	trouble description of component	trouble description of motorcycle	repair method
frame	Frame is struck or has fallen down.	Frame is distorted.	Motorcycle cannot run normally.	Correct or replace frame.
	Frame is struck or has fallen down.	Frame parts or crazes.	Motorcycle cannot run.	Joint or replace frame.
	Frame is influenced by road and is shaken.	The jointing of frame breaks off.	Motorcycle shakes or cannot run normally.	Joint frame.
side stand	Side stand is distorted or parts.	Side stand cannot return normally.	Motorcycle makes sound during running and parking is influenced.	Correct or replace side stand.
	Returning spring loses springiness.	Side stand cannot return normally.	Motorcycle makes sound during running and parking is influenced.	Replace returning spring.
left cover	Left cover is damaged for being struck.	Left cover is damaged.	Appearance is influenced.	Replace or repair left cover.
right cover	Right cover is damaged for being struck.	Right cover is damaged.	Appearance is influenced.	Replace or repair right cover.
front fender	Front fender gets strike or shake.	Front fender is distorted or damaged.	Motorcycle makes sound during running.	Replace front fender.
rear fender	Front fender gets strike or shake.	Rear fender is distorted or damaged.	Motorcycle makes sound during running.	Replace rear fender.
seat	—————	Seat cover is damaged.	The comfort of riding declines.	Replace seat.
front pedal	—————	Front pedal is distorted or damaged.	Riding safety is influenced.	Replace front pedal.
rear pedal	—————	Rear pedal is distorted or damaged.	Comfort for rider declines.	Replace rear pedal.
starting lever	—————	Starting lever is distorted or damaged.	Starting performance is influenced.	Replace starting lever.
rear view mirror	Rear view mirror gets strike or shake.	Rear view mirror is distorted or damaged.	Riding safety is influenced.	Replace rear view mirror.
rear carrier	Rear carrier gets strike or shake.	Rear carrier is distorted or jointing breaks off.	Setting of loads is influenced.	Joint or replace rear carrier.

## Section 6 Steering System

The direction of motorcycle is operated by steering handlebar. The steering handlebar connects with direction pole. It sees the frame as the center and run the front shock absorber and operate the front wheel through the rotation of direction pole.

### 1 The Structure and Working Principle of Steering System

#### [1] Steering handlebar

The right steering handlebar of motorcycle is the throttle control grip, Control oil flow rate. The right holding lever is the front brake lever. Also, there are left and right controlling switches, rear view mirror and choke switch respectively installed on the left and right handlebar.

#### [2] Direction pole assembly

Direction pole assembly is the important part of steering system. It mainly consists of direction pole, lower connecting board, bearing and bearing ring. Normally, the direction pole is jointed with lower board (wholly called direction pole) and installed within the frame pipe. The weight of motorcycle and rider transfers to front wheel through the direction pole. However, the weight caused by the strike of road for the front wheel transfers to motorcycle body through the direction pole. Therefore, direction pole not only must bear the big loads strike, but also ensure the flexible turning during running.

### 2 Disassembly and Maintenance of Steering System

In order to make motorcycle keep a good operation, you should maintain the steering system timely. For the first time, disassemble vehicle after 1500km, and then disassemble it every 600km. Check the abrasion of inner and outer bearing and rolling ball. Replace them if necessary. When replacing rolling ball, you must replace it completely. Don't mix the new parts with the old ones.

The maintenance of direction pole should stress on bearing. If the bearing is always lack of lubrication and adjusting nut is loose, the clearance of bearing will be too big, so that the steering handlebar will shake during running, which influences the stability and safety of motorcycle. On the other hand, if the bearing is damaged or adjusting nut is too tight, the turning resistance of steering handlebar will be too big, so that the steering handlebar will be locked, which is hard to be operated or cannot be operated. Therefore it influences riding safety.

Support motorcycle with main stand and make front wheel off the ground. Rotate the front fork and front shock absorber and check whether the bearing is loose. Turn the steering handlebar and check whether the bearing is flexible. Adjust it if the bearing is too loose or tight. First, unscrew the locknut of direction pole, rotate adjusting nut and check the tightness of bearing. Re-tighten the locknut until the bearing is normal.

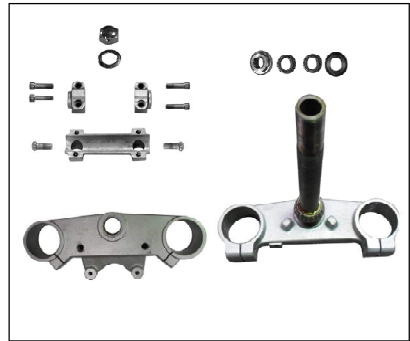

The cause, trouble description and repair method of direction pole

Table 4-6 Maintenance of direction pole

component description	cause	trouble description of component	trouble description of motorcycle	repair method
bearing ring	Adjusting nut is too tight.	The match clearance of bearing and bearing ring is too small.	Turning handlebar is not flexible.	Adjust nut with lock wrench until the handlebar is flexible and there is no bearing rolling between direction pole and frame pipe.
	Bearing ring is too worn or damaged and has pit, press mark and spit.	—————	Turning handlebar is not flexible and shakes during running.	Wholly replace bearing ring.
bearing	Bearing is worn, distorted or damaged.	—————	Turning handlebar is not flexible and shakes during running.	Wholly replace ball bearing
direction pole	Direction pole is distorted.	Direction pole is distorted.	Turning handlebar is not flexible.	Correct or replace direction pole.

## Section 7 Operating Steel Wire

### 1 Structure and Working Principle of Operating Steel Wire

Operating steel wire mainly consists of steel wire, wire head and metal spring plastic hose. The steel wire should be soft so that it doesn't break off easily and it can bear big pressure. It is normally made of several thin wires, which ensure the intensity of steel wire and make it soft. The wire head is connected with steel wire through the method of stannum jointing, zinc alloy die-casting and so on. The outside of metal spring plastic hose is plastic and inside is a spring hose made of steel wire, which can bear any bending and won't change the length when suffers axial pressure. There is a nylon bushing between the steel spring plastic hose and steel wire, which avoids the direct friction of steel wire and spring hose.

### 2 Maintenance of Operating Steel Wire

In order to keep operating steel wire working well and prolong its service lifetime, timely cleaning and lubricating is necessary. For the first time, you can do it after 1500km, and then every 3000km. Here are two methods for lubrication: one is dip in, the other is injection.

#### Dip In Lubrication

Operate as follows:

[1] Dip the whole steel wire in coal oil for 5-10min. Pull the steel wire to clean out the deposit in hose.

[2] Dip the whole steel wire in the mixed oil which has percentage of 1:1 of coal oil and lubeoil. Pull the steel wire to make mixed oil flow into the hose.

[3] Remove operating steel wire and clean the mixed oil outside.

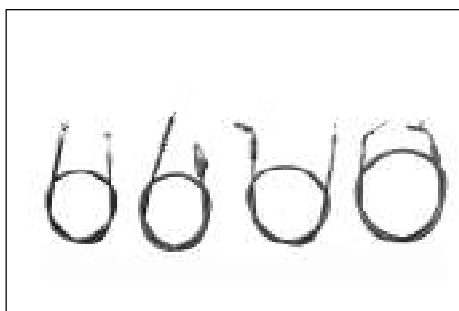

#### Injection Lubrication

Operate as follows:

[1] Enlace the end of metal spring plastic hose of operating steel wire with transparent adhesive tape. Make it as a pipe, as the picture:

[2] Raise the end with adhesive tape and pull out of steel head.

[3] Dip lubeoil in the hose with oil kettle until there is oil dripping from the lower steel wire.

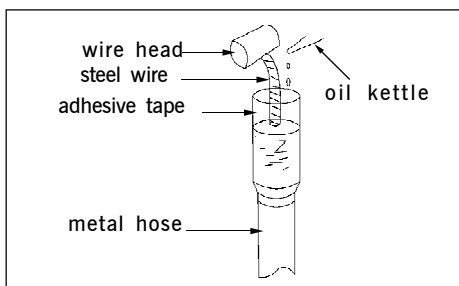

The cause, trouble description and repair method of operation system

Table 4-7 Maintenance of Operation System

component description	cause	trouble description of component	trouble description of motorcycle	repair method
handlebar	Handlebar is distorted.	Handlebar is distorted.	Motorcycle runs towards one side.	Correct or replace handlebar.
Operating steel cable of clutch	Steel wire cannot flexibly pulled outside the cable.	Clutch handlebar is hard to be operated or cannot be returned well.	Clutch slides or cannot disengage completely.	Clean, lubricate or replace operating steel cable.
	Steel wire breaks off.	—————	Clutch cannot disengage completely.	Replace operating steel cable.
rear brake pedal	The free stroke is too small.	—————	Rear brake pedal cannot be returned to the original place.	Readjust the free stroke.
	The free stroke is too big.	—————	Rear brake loses control.	Readjust the free stroke.

## Section 8 Shock Absorber

Front shock absorber is the spring connecting part between front wheel and vehicle body. Rear shock absorber mainly bear axial pressure of rear wheel. Both of them support the weight of the whole vehicle body. During motorcycle running, it reduces the concussion and shake for motorcycle and rider, reduces the pressure for components, prolongs the service lifetime of motorcycle and enhances the comfort, operation and stability for rider.

### 1 The Structure and Working principle of Front/Rear Shock Absorber

#### [1] Front Shock Absorber

The front shock absorber of this motorcycle adopts compound of hydraulic pressure and spring. It mainly consists of front shock absorber spring, seal ring, dustproof cover, piston ring, front shock absorber pole, piston lever, buffer spring, one-way valve spring socket, one-way valve spring, one-way valve, one-way valve socket, front shock absorber pipe and piston lever socket.

When the front wheel of motorcycle gets strike and shake, the front shock absorber pipe rises, the damping oil flows up through the one-way valve and small holes on piston lever. The resistance power is small at this time. When absorber pipe continues going up, the clearance between one-way valve socket and the cone-shaped surface of piston lever becomes smaller and smaller, so that the resistance becomes bigger, which avoids the bump of front shock absorber pipe and front shock absorber. When front shock absorber pipe goes down for the returning of front shock absorber spring, the damping oil only can flow from the small holes of piston lever because of the close of one-way valve, which causes a big resistance, so that it reduces the shake of front shock absorber spring.

#### [2] Rear Shock Absorber

The rear shock absorber of this motorcycle adopts compound of hydraulic pressure and spring. It mainly consists of upper tie-in, rubber cover, gasket, rear shock absorber spring, rear shock absorber lever, piston, damper and lower tie-in.

Rear shock absorber mainly gets the axial pressure of rear wheel. When the rear wheel gets the strike or shake for the road condition, rear shock absorber will compress and expand. The hydraulic pressure oil of damper is forced to flow through the damping hole, so it reduces the shake of rear shock absorber spring.

### 2 Disassembly and Maintenance of Front Shock Absorber



[1] Check the effective stroke and performance of front shock absorber, and check whether there is leakage from front shock absorber.

#### CAUTION

► Maintain front shock absorber in time if it has some problems in order to ensure the riding safety.



[2] Dismantle four fixed bolt of front shock absorber, and remove the front shock absorber.

[3] Dismantle bolt of front shock absorber and drain front shock absorber oil. Check whether the oil is bad. Replace it if bad.

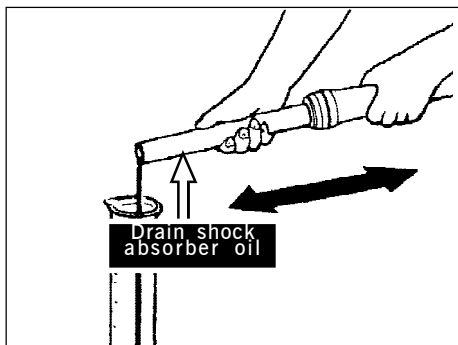

[4] Remove the oil seal and spring clamp of front shock absorber and check whether the edge of oil seal is worn. Replace it if necessary.

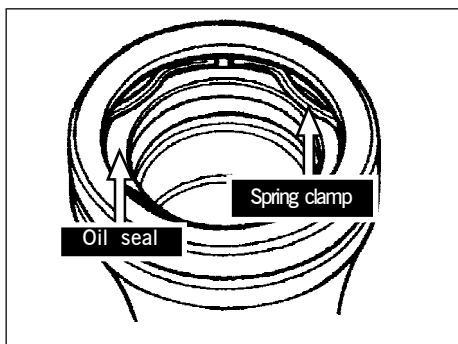

[5] Dismantle front shock absorber pole and lower pipe. Check their abrasion. Replace them if worn.

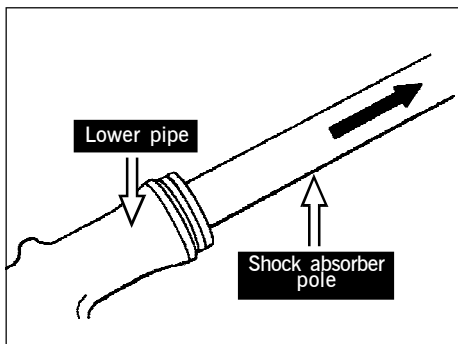

[6] Remove the returning spring of shock absorber pole and check its abrasion and distortion. Replace it if distorted.

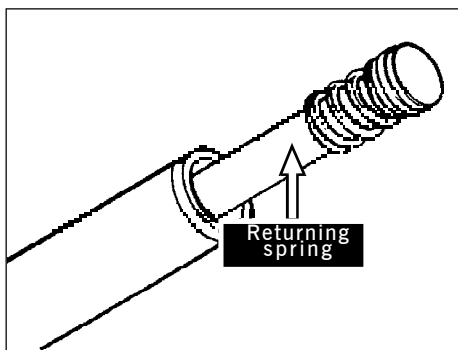

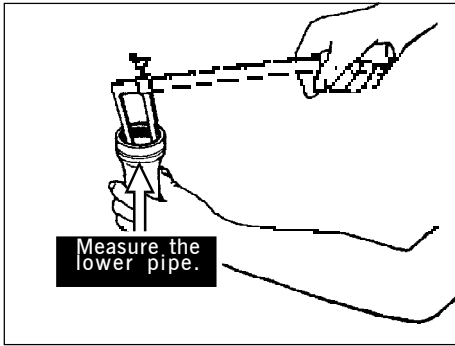

[7] Measure the inner diameter of lower pipe of front shock absorber with callipers. Check whether it exceeds the limit value of maintenance. Replace it if exceeds.

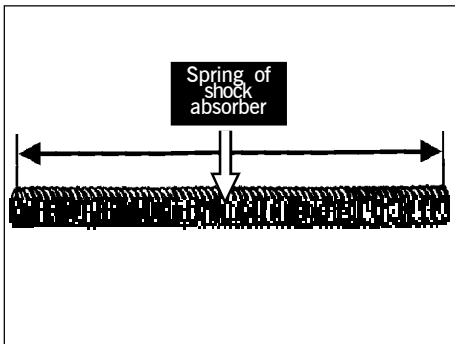

[8] Remove the returning spring of front shock absorber and check its abrasion. Replace it if worn.

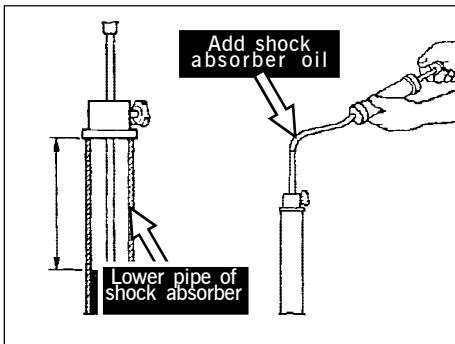

[9] When installing front shock absorber, add front shock absorber oil according to the stated. The standard volume of front shock absorber is  $(330 \pm 5)$  mL.

### 3 Disassembly and Maintenance of Rear Shock Absorber



[1] Check whether the spring of rear shock absorber becomes soft and its damper has leakage. Replace shock absorber assembly if the rear damper has leakage.

[2] Check whether the left one has the same length as the right one and check whether the spring surface of shock absorber is damaged. Replace it if damaged.



**CAUTION**

► When rubber components have abrasion or aging, replace them.

4 The cause, trouble description and repair method of front/rear shock absorber

Table 4-8 Maintenance of Front/Rear Shock Absorber

component description	cause	trouble description of component	trouble description of motorcycle	repair method
front shock absorber	The front shock absorber spring has poor elasticity or breaks off.	Front shock absorber is soft or makes strange sound.	The comfort, stability and safety of riding decline.	Replace front shock absorber or spring.
	Front shock absorber pole is distorted.	Left pole and right pole are not at the same level.	Motorcycle runs towards one side and comfort, stability and safety are influenced.	Correct and replace front shock absorber and front shock absorber pole.
	The surface of front shock absorber is damaged.	The oil seal of front shock absorber pole has leakage.	The comfort, stability and safety of riding decline.	Replace front shock absorber or its pole.
	The chrome plating tier of front shock absorber is worn so that the metal part appears.	The oil seal of front shock absorber pole has leakage.	Motorcycle runs towards one side and comfort, stability and safety are influenced.	Replace front shock absorber or its pole.
	The lower pipe of front shock absorber is worn or breaks off.	Front shock absorber has leakage.	Motorcycle runs towards one side and comfort, stability and safety are influenced.	Replace front shock absorber or its lower pipe.
	Piston lever is worn or damaged.	Front shock absorber is too soft.	The comfort, stability and safety of riding decline.	Replace front shock absorber or piston lever.
	Piston ring is worn or damaged.	Front shock absorber is too soft.	The comfort, stability and safety of riding decline.	Replace front shock absorber or piston ring.
	The edge of oil seal is worn or damaged.	Oil seal has leakage. Front shock absorber is too soft.	The comfort, stability and safety of riding decline.	Replace oil seal of front shock absorber.
	The oil of front shock absorber is not enough or bad.	Front shock absorber becomes soft.	The comfort, stability and safety of riding decline.	Add or replace front shock absorber oil according to the stated.
rear shock absorber	The spring of rear shock absorber breaks off or has poor elasticity.	Rear shock absorber is too soft.	Motorcycle runs towards one side and comfort, stability and safety are influenced.	Replace rear shock absorber.
	Rear damper has leakage.	Rear shock absorber is too soft.	The comfort, stability and safety of riding decline.	Replace rear shock absorber.
	The piston lever of rear damper is distorted or breaks off.	Rear shock absorber is distorted.	Motorcycle runs towards one side and comfort, stability and safety are influenced.	Replace rear shock absorber.
	The upper and lower connecting rubber cover are worn or have aging.	Rear shock absorber is distorted or makes sound.	The comfort, stability and safety of riding decline.	Replace upper and lower connecting rubber cover.



## Section 9 Rear Fork

The rear fork connects rear wheel with frame. It makes rear wheel rotate around a fixed point through rear shock absorber to reduce the strike and shake of rear wheel.

### 1 The Structure and Working Principle of Rear Fork

Because rear fork gets big strike and shake, the requirement on material and jointing is very high. It is made through the method of jointing and so on. It mainly consists of rear fork, dust seal, dustproof seal cover and rear cover of bearing.

In order to keep rear fork rotating up and down around the vehicle body, there is bearing shaft or bearing installed at the connection of rear fork and vehicle body. When rear fork rotates, it will make rear wheel more flexibly and more stably.



### 2 Disassembly and Maintenance of Rear Fork

[1] Check whether rear fork is distorted or cracks because of the outside force, whether the match clearance of each component of rear fork becomes big, and whether the rotating times of rear fork is too much.

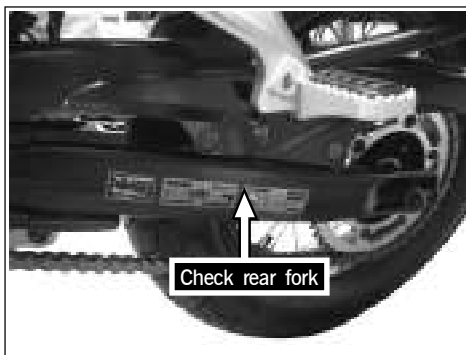

#### CAUTION

► Replace or maintain rear fork in time if it has the problems above to ensure the comfort and safety of riding.

### 3 The cause, trouble description and repair method of rear fork

Table4-9

Maintenance of Rear Fork

component description	cause	trouble description of component	trouble description of motorcycle	repair method
rear fork	Rear wheel gets strike.	Rear fork is distorted.	Motorcycle runs towards one side and comfort, stability and safety are influenced.	Correct or replace rear fork.
	Motorcycle falls down and rear fork breaks off.	Rear fork breaks off.	Motorcycle cannot run normally.	Joint or replace rear fork.
	The strike and shake to rear wheel is too big.	The jointing of Rear fork breaks off.	The comfort, stability and safety of riding decline.	Joint rear fork.
	The road is bad and the strike and shake to rear wheel are too big.	The dust seal of bearing cover of rear fork is worn.	The seal of bearing cover or bearing of rear fork is bad.	Replace dust seal of rear fork bearing cover.

## Section 10 Wheel

Front/rear wheel is the running component of motorcycle. It supports the weight of whole motorcycle and ensures a friction made by wheel and road to make wheel avoid sliding. Wheel can reduce and absorb the strike and shake caused by the road. The front wheel cooperates with operating part, which fixes the direction of running. The rear wheel is transferred power by engine, which drives motorcycle to run. Wheel mainly consists of outer tire, inner tire, aluminium tire, tire hub, bearing, bush, oil seal and axle.

### 1 The Structure and Working Principle of Wheel

#### [1] Tire

The tire of motorcycle is the important component of riding system. Its function is to touch road surface directly, support the weight of whole motorcycle, reduce strike and shake during running with its elasticity, ensure balanced motorcycle running and avoid sliding. Tire consists of outer tire, inner tire and gasket.

#### Outer Tire

Outer tire consists of tire surface, tire body, gasket and tire ring. The surface of outer tire directly touches road surface. There are different thread on tire surface, which helps motorcycle avoid sliding on different road. The tire body has a certain intensity, but in order to emit heat, it had better not be too thick. The tire ring is packed by the edge of curtain and steel ring, which makes outer tire fix on the rim. If the perimeter of tire ring is too short, which will make the disassembly of outer tire more difficult and if the perimeter is too long, which will make outer tire spring out. The curtain tier is the framework of outer tire. But the curtain tier of outer tire crosses with the transect of tire, which makes an angle. But the curtain tier of meridian tire arrays as the direction of earth meridian. The meridian tire has the good characters of reducing power consumption, fuel consumption and prolonging service lifetime.

#### Inner tire and Gasket

Inner tire is made of rubber. It is a circle. There is a valve on it, which can adjust the pressure of inner tire. The main requirement of inner tire is seal. The pressure of inner tire is the main reason of influencing the usage of wheel and tire. The gasket is a round rubber cincture, which separates inner tire and rim, protects the seal of inner tire and prevents the break caused by the spiculate thing.

#### [2] Rim

Rim is the framework for supporting and fixing the tire. The rim of this motorcycle has two types, die-casting rim and spoked rim. The former is made from aluminum alloy, which integrates the rim and hub by casting and then machining. This kind of rim has high intensity, simple arts and crafts, convenient installation, but poor elasticity and cannot be adjusted. If the rim is distorted or damaged, you should replace the whole rim. The spoked rim is made from steel strip. In the wheel rim, there is a lot of hole seats, in which a spoke and spoke nut are installed. The other end of spoke connects the wheel hub. Therefore, the spoked rim has a good shock resistance, adjustable characteristic and convenient maintenance. In this part, it mainly discusses the die-casting rim.

#### [3] Wheel Hub

The wheel hub of motorcycle is divided into front hub and rear hub. The structure of front hub and rear hub is very familiar. The rear wheel is drive wheel, so there is power transmission device installed on rear hub. There are bearing, bearing gasket, oil seal and axle installed in the front and rear hub, which is good for the operation of wheel hub.

### 2 Disassembly and Maintenance of Wheel

[1] Check whether tire pressure is within the normal scale. Clean out the deposit of outer tire thread. Avoid inner and outer tire damaged.



#### CAUTION

► Check the abrasion of outer tire. Replace it if it exceeds the limit value: 2.00mm.

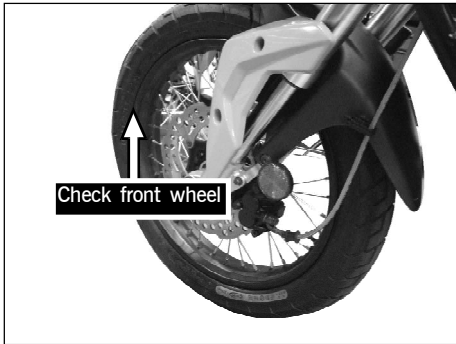

[2]If front wheel is deformed by striking or vibration, so that the bike run out of way or steering control trembling or vibrating. The wheel need to be replaced or adjusted.

**⚠ CAUTION**

► Replace the wheel when it trembling over the maintenance limit value.

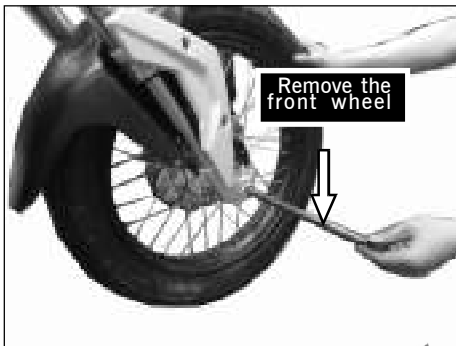

[3]Before dismantling front wheel, fix the bike first and leave the wheel of ground, then take off tightening nut of front wheel shaft (M14) and take out front wheel shaft and front wheel assembly.



[4]Take out front wheel shaft bush to check whether it was abraded. If it was worse,replace it.

**⚠ CAUTION**

► Add grease when assembling the bush.

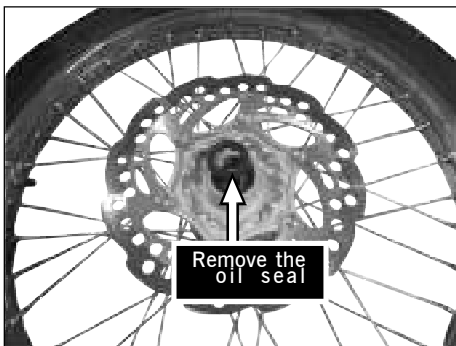

[5]Take out the oil seal to check whether the blade is abraded. Replace it when needed.

[6]Put front wheel on rectification desk and rotate it in high speed to check the abrasion condition and free strock. if it is abraded, dismantle it and replace.

**CAUTION**

► When there is noise or free strock turn wide, replace it with new bearing. And assemble beering with the oil seal inside.

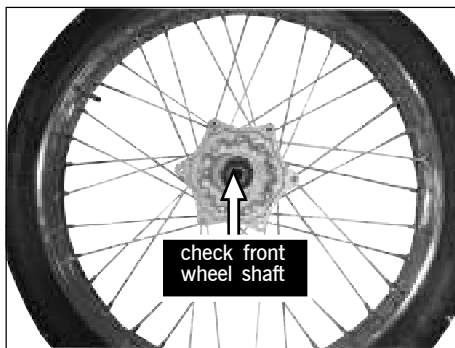

[7]If front wheel shaft abrade badly, knock it out by using shaft disassembling tools and replace it with the new one.

**CAUTION**

► When assembling front wheel shaft, add grease on it and assemble beering with the oil seal inside.

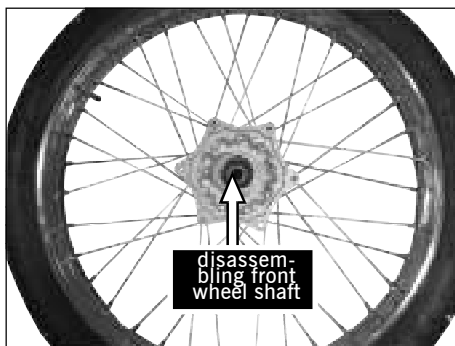

[8]Put front wheel on rectification desk to check the vibration of it. Rotate it with hand and use dial indicator to test the value and read the value.

Maintainance limit value:

Radial 2.0mm

Axial 2.0mm

**CAUTION**

► If the vibration value is over maintainance limit value above, rectify or replace it.

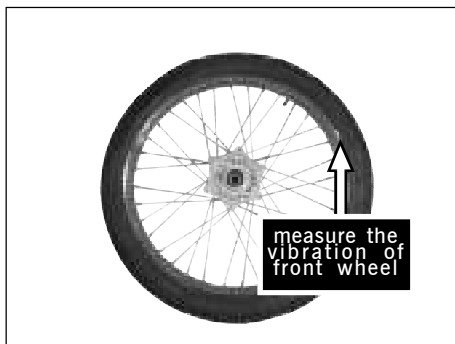

[9]Check the abrasion of front outer tyre. The maintainance limit value of front outer tyre thread is 2.00mm. If the pressure of front wheel is insufficient, check whether inner tyre valve core has leakage,then check whether inner tyre has leakage.

**CAUTION**

► If inner tyre valve core has leakage, repair or replace the core, If inner tyre has leakage, fix or replace inner tyre.





[10] Dismantle the locknut of rear axle. Remove rear axle and rear wheel assembly.

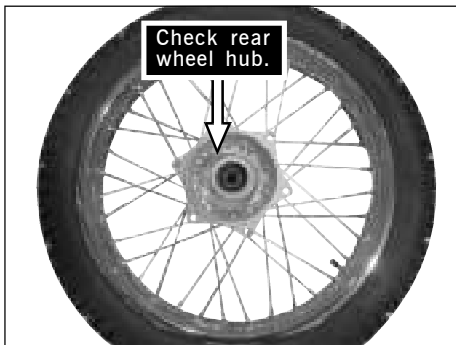

[11] Dismantle rear wheel and check whether rear wheel hub is damaged. Replace it if damaged.

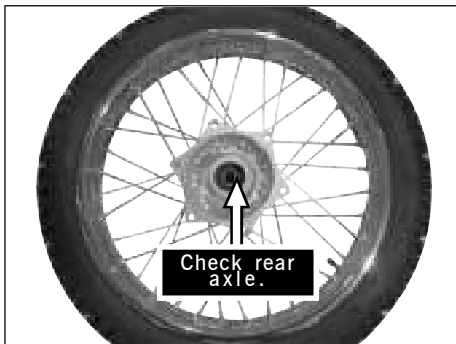

[12] Check whether rear axle is worn. Replace it if worn.

 CAUTION

► Smear lubricant when installing..



[13] Check whether the front and rear rim are distorted. Correct or replace them in time. Check whether the outer tire thread of rear wheel is worn. Replace outer tire if the abrasion value exceeds 2mm.

### 3 The cause, trouble description and repair method of wheel

Table4-10 Maintenance of Wheel

component description	cause	trouble description of component	trouble description of motorcycle	Repair method
front wheel	Front wheel is distorted.	Front wheel is distorted.	Motorcycle runs towards one side and turning handlebar shakes during running.	Replace front wheel.
	The bearing hole of wheel hub is worn.	The match of bearing hole of wheel hub and bearing is too loose.	Motorcycle runs towards one side and turning handlebar shakes during running.	
	Bearing is worn or damaged.	The axial and radial clearance of inner and outer bearing is too big or its rotation is not flexible.	Motorcycle runs towards one side and turning handlebar shakes during running.	Replace bearing
front wheel	Tire is worn.	—————	It is easy to slide during running and it is hard to avoid side sliding.	Replace outer tire.
gear box of speedometer	Gear is damaged.	—————	Speedometer finger cannot swing.	Replace the gear box of speedometer.
	The transmission ring of gear wheel is damaged.	—————	Speedometer finger cannot swing.	Replace the gear box of speedometer.
rear wheel	Rear wheel is distorted.	Rear aluminium wheel is distorted.	Motorcycle runs towards one side and rear wheel shakes during running.	Replace bearing.
	Rear wheel is damaged.	—————		
	The bearing hole of wheel hub is worn.	The match of bearing hole of wheel hub and bearing is too loose.		
	Bearing is worn or damaged.	The axial and radial clearance of inner and outer bearing is too big or its rotation is not flexible.		
rear tire	Rear tire is worn.	—————	It is easy to slide during running and it is hard to avoid side sliding.	Replace outer tire.

## Section 11 Brake

Motorcycle usually needs to decelerate and stop during riding, so brake is used to make resistance to wheel to achieve that purpose. For normal motorcycles, front brake is operated by right hand and rear brake is operated by right foot. However, among some motorcycles with automatic clutch, such as moped or scooter, the rear brake can be operated by left hand. The brake of motorcycle consists of drum brake and disc brake. This motorcycle adopts front disc brake and rear drum brake.

### 1 Structure and working principle of brake

Disc brake consists of mechanism type and hydraulic type. At present, hydraulic brake is in common use on motorcycle. The hydraulic brake normally consists of brake handle (brake pedal), main oil reservoir, reserve oil reservoir (The reserve oil reservoir and main reservoir are usually integrated), brake caliper, brake disc and brake oil pipe. When operating brake, brake handle compresses the main oil reservoir, which enhances the pressure in hydraulic pressure system, drives the main piston in brake caliper and tightens the friction pieces on brake disc. Therefore, the brake disc fixed on wheel can get the braking power. The characters of disc brake is soft working, automatic cleaning and hard to lose control.

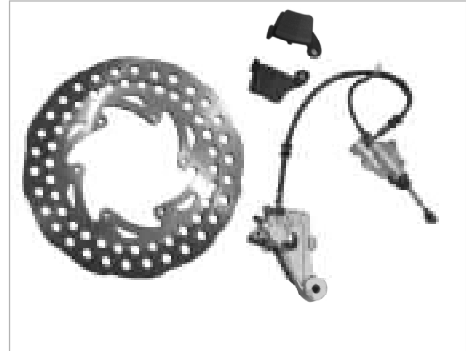

Structure drawing of disc brake

### 2 Disassembly and maintenance of brake

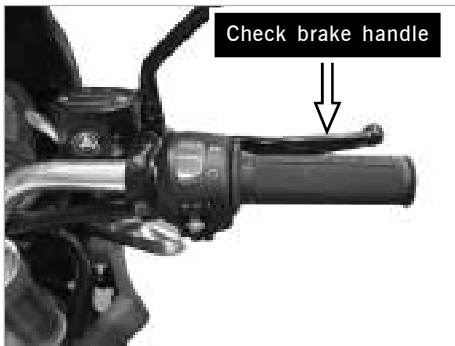

[1] Hold front brake control with right hand to check the brake performance of front brake. The standard free stroke is: 10mm~20mm

#### CAUTION

► If front brake control can not reach the standard value, readjust front brake.

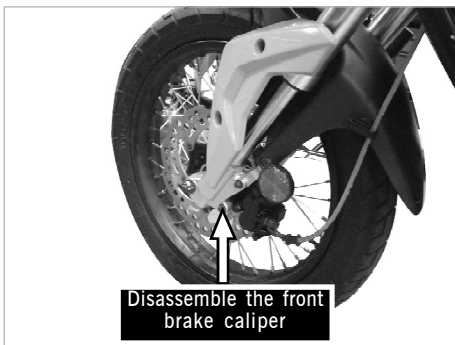

[2] Disassemble the front brake pliers locking bolt, remove the front brake caliper

[3] Disassemble disc brake friction plate and check the piston of brake caliper for working condition. If it cannot work well, repair or replace hydraulic brake.

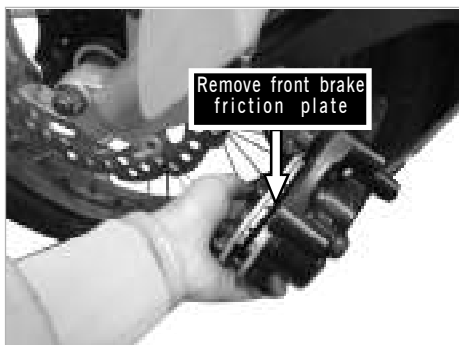

[4] Disassemble locking nut of front axle and Mileage line, then remove the front wheel.

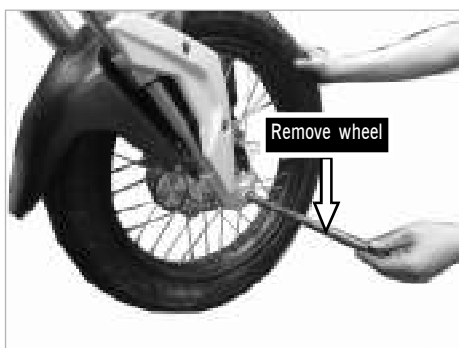

[5] Remove the speed counter and check the wear breaking of the seal blade. Replace it if necessary



[6] Remove the front wheel, remove the front brake disc fixed bolt, remove the front brake disc.



 **WARNING**

► Please smear glue on the bolt before installing the front brake disc to avoid bolt looseness.



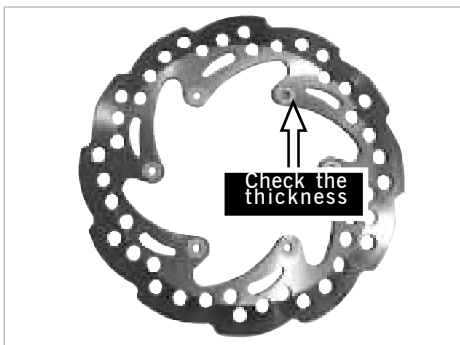

[7] Measure the thickness of front brake disc with micrometer. The limit value of repair is 2.0mm.

**CAUTION**  
 ▶ If the thickness of brake disc exceeds the limit value of repair 2.0mm, replace the brake disc.

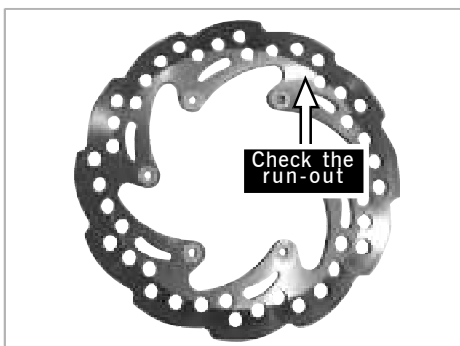

[8] Measure brake disc run-out with dial indicator, and the limit value of repair is 0.3mm.

**CAUTION**  
 ▶ If the run-out of brake disc exceeds the limit value of repair 0.3mm, replace the brake disc.

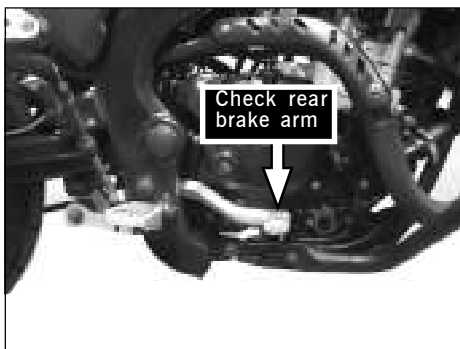

[9] Step rear brake pedal by foot, check it for performance. The standard free stroke of brake pedal is: 20mm ~ 30mm.

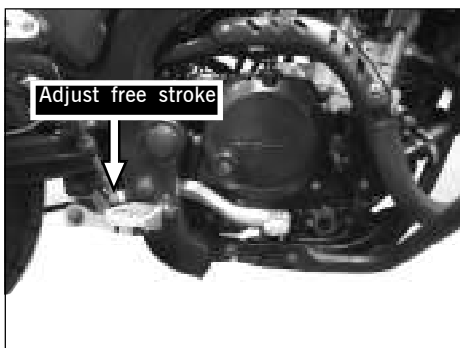

[10] If the free stroke of rear brake pedal cannot reach the standard value, readjust the nut of rear brake rod.

[A] Regulate adjusting nut of rear brake and adjust the free stroke of rear brake pedal to 20mm ~ 30mm.  
 [B] Step rear brake pedal for several times and release it. Rotate the rear wheel assembly and check the rear wheel for free rotation.

[11] Disassemble the nut of rear wheel axle and remove the wheel axle and rear wheel assembly.

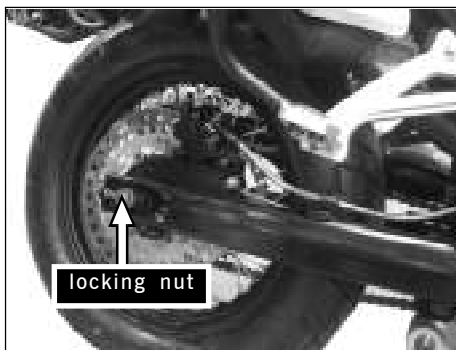

[12] Remove friction lining and Measure the thickness of it with the limit value of repair is 2.0mm. Check the piston of brake caliper. If it cannot run normally, fix or replace hydraulic brake.

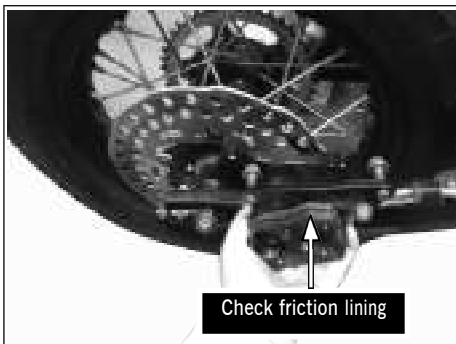

[13] Disassemble the fixed bolt of brake disc and remove it.

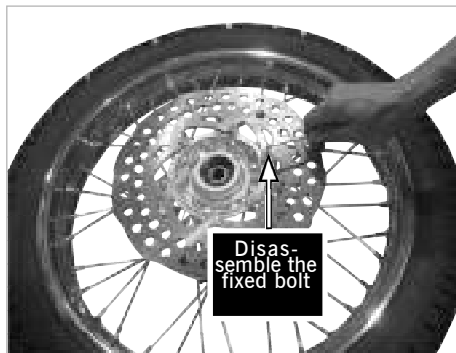

**WARNING**  
▶ Please smear glue on the bolt before installing the rear brake disc to avoid bolt looseness.

[14] Check the wear for brake disc. measure the inner diameter by callipers. The limit value of repair is 131.0mm.

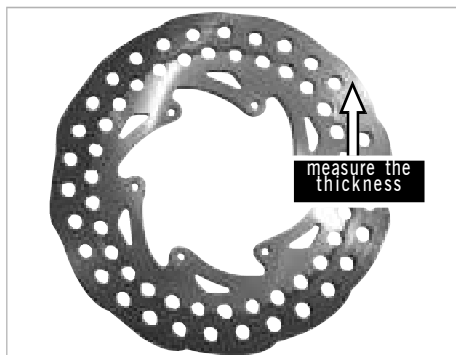

**WARNING**  
▶ If the value of inner diameter exceed the limit value, replace it.

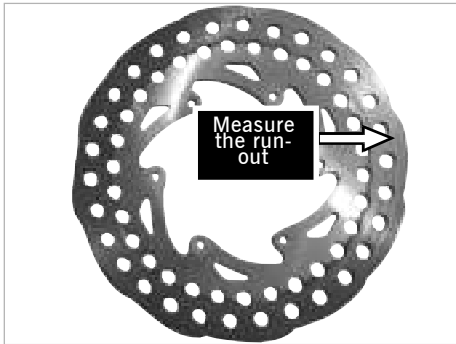

[15] Measure the run-out of brake disc by dial indicator and the limit value is 0.3mm.

**⚠ CAUTION**

▶ If the value of run-out exceed the limit value, replace it.

3 The cause, trouble description and repair method of front/rear brake see Table 3-13:

Table 3-11 Maintenance of Front/Rear Brake

Component	Cause	Trouble description of component	Trouble description of motorcycle	Repair method
Brake pads	Friction plates are worn.	—————	Brake is out of control or brake pads cannot return.	Replace brake pads as a set.
	The end of brake pad is worn to a slot.	—————	Rear brake makes abnormal sound or is out of control.	
	The area of brake shoe touching with brake drum is too small.	—————	Brake is out of control	Repair or replace friction plates of brake pads
	The elasticity of brake shoe spring is not enough or broken.	—————	Brake pads cannot return.	Replace return spring.
Brake cam	Moving parts are rusty or have foreign things.	The rotation of brake cam is not flexible.	Brake is out of control or cannot return.	Clean and lubricate brake cam.
	The circle surface of brake cam is worn.	—————	Brake is out of control	Replace brake cam.

## Section 12 Meter

The meter of motorcycle is to indicate the working condition of motorcycle.

### 1 The Structure and Working Principle of Meter

#### [1]Speedometer

Speedometer is to indicate the running speed of motorcycle and the total mileage.It is driven by front wheel.The rev of front wheel is sent to speedometer through gearshift system and soft axle,which makes magnetic cylinder rotate.Coil cuts magnetic wire,which makes whirlpool and magnetic field to cooperate with the magnetic field of magnetic cylinder,makes whirlpool disc get a torque,overcomes a resistance and drives the finger to rotate.The higher the speed is,the stronger the magnetic field of whirlpool disc is.The torque is bigger,so the angle of finger swing augments and it can reach the higher mark on board.Meanwhile,the rotating main axle drives counter through whirlpool lever.Therefore,the total mileage of motorcycle is indicated by the counter. Maintain speedometer once a year.Add lubeoil to where it needs.

#### [2]Fuel Meter

Fuel meter is to indicate the fuel volume in fuel tank.It guides the resistance changes in sensor which caused by the change of fuel level to fuel volume indicator and indicates the change of fuel volume through fuel volume indicator.



### 2 Disassembly and Maintenance of Meter

[1]When fingers of meter don't work,dismantle speedometer and check it.

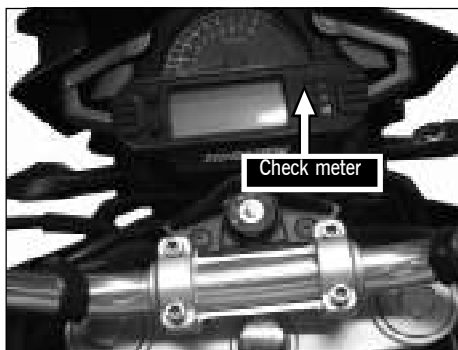

[3]Check whether the connection of speedometer is looseness.

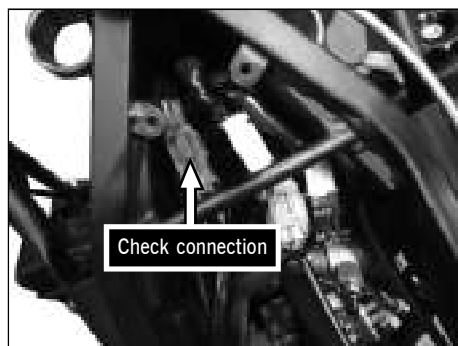

### 3 The cause, trouble description and repair method of meter

**Table4-12 Maintenance of Meter**

component description	cause	trouble description of component	trouble description of motorcycle	repair method
meter assembly	The filament of indicator is burned-out.	The filament of indicator is burned-out.	Indicator doesn't work.	Replace bulb of indicator.
	The filament of meter head lamp is burned-out.	The filament of meter head lamp is burned-out.	Meter, head lamp doesn't work.	Replace the bulb of meter indicator.
	Speedometer is damaged.	Speedometer is damaged.	Speedometer doesn't work.	Replace speedometer

## CHAPTER 4 ELECTRICAL SYSTEM

### Part 1 Basic Knowledge

In order to get a further understanding of structure and working principle of motorcycle electrical system, you should have a general conception about basic knowledge of electrics firstly.

#### 1 Electricity, electric current, voltage and resistance

The basic component of any substance is atom. There exists electropositive atomic nucleus and electronegative electron inside the atom. The quantity of nucleus is the same as electron, so which makes the positive electricity counteract the negative electricity and causes atom to be neutral. If the substance is influenced for friction or magnetic field, this balance will be broken. So the electron will increase or decrease because of moving. At that time, the substance has electric charge because the atom is not neutral. The electric charge of substance has the relationship with the increasing and decreasing of atom. When the atom increases, the substance will be electronegative. When the atom decreases, the substance will have positive electricity.

Electric charge moves regularly in conductor along a stated direction, which is called electric current. The quantity of electric charge per second is used to scale the strength of electric current. In electrics, we use  $I$  to stand for electric current. Its strength unit is Amp(A). Normally, the stated direction of electric current is from the anode of battery to the cathode.

There is an interaction force between electric charge. In order to make electric charge move, such force must be overcome. When moving the positive charge, the work for conquering the force between electric charge is called potential. The differential potential between any two points is called voltage. We use  $U$  to stand for and its unit is V.

When electric current flows in a substance, the substance will produce a resistance, which is called electric resistance. We use  $R$  to stand for, its unit is  $\Omega$ . Different substance has different resistance. For example, the resistance of copper, iron, aluminium is small, which is called conductor. However, the resistance of wood, china, plastic is big, which is called dielectric. Also, there are some other substances, such as silicon, whose electric performance is between conductor and dielectric, which is called semiconductor.

#### 2 Ohm's Law

Ohm's law indicates the relationship among voltage, resistance and electric current. Viz. Electric current ( $I$ ) and voltage ( $U$ ) have direct proportion and electric current ( $I$ ) and resistance ( $R$ ) have inverse proportion. Its formula is  $I=U/R$ : Also,  $U=IR$ ,  $R=U/I$ .

#### 3 Electric apparatus, direct current(DC), alternating current(AC) and electrical source

Electric apparatus is usually called load, which is an equipment that can consume electric power and transfer the power to other kind of power.

The device which offers power to electric apparatus is called electrical source or power supply.

The electric current what electrical source offers to electric equipment has two types: One type whose intensity and direction don't change according to the change of time is called direct current(DC). The other one whose intensity and direction change periodically according to the change of time is called alternating current(AC).

#### 4 Circuit, series circuit and parallel circuit

The closed circuit which is made up of electrical source, electric apparatus and connecting lead is called circuit. The circuit is divided into two basic types: series circuit and parallel circuit. In series circuit, several electric apparatuses connect with each other and there is no cut in the middle. At this time, the electric current which is through each electric apparatus is the same. But in parallel circuit, the beginning and the end of each equipment connects between the two points and the voltage of two end is the same. In the complicated circuit of motorcycle, both series circuit and parallel circuit coexist.

#### 5 Short circuit and open circuit

In a normal circuit, if two leads, of which electrical source passes electric apparatus, don't pass electric apparatus and connect with each other, which is called short circuit. In the circuit which is made up of electrical source, electric apparatus and connecting lead, because of the cut of lead, it makes electric current not form a closed circuit, which is called open circuit.

#### 6 Left-hand rule and right-hand rule

In the magnetic field which can produce electromagnetism induction, stretch out the left hand, make palm flat, make thumb plumb the other four fingers, let magnetic line plumb and get through the center of palm and make four fingers towards the direction of electric current. At this time, the direction which thumb points to is the direction of magnetic field power, which is called left-hand rule.

Unwind the thumb of right hand, hold coil along the direction of electric current with the other four fingers. At this time, the direction which the thumb points to is the direction of magnetic wire which coil produces magnetic field, which is called right-hand rule.

Electrical system is an important part of motorcycle. Its structure and function directly influence the performance and riding comfort of motorcycle. The electric system is divided into three parts: power supply, control and power consumption. Because the ignition system of electrical system is the core of motorcycle, it is described in the engine part. During the common usage, you should maintain the electrical system frequently. The common trouble of electrical system of motorcycle can be looked up through the circuit diagram, so the circuit diagram is attached both in user's manual and maintenance manual.

## Section 2 Power Supply

### 1 The structure and working principle of power supply

Power supply part mainly consists of generator and battery. Its function is in the closed circuit of motorcycle, generator and battery has parallel connection and offers electric current to the electro-equipment in electrical system, then stores the rest power in battery.

According to the character of electric current export, generator can be divided into DC generator and AC generator. According to the different structure, the AC generator can be divided into AC flywheel generator, AC magnet rotor generator and AC three-phase generator. The magnetic pole of first two has permanent magnet, so it is also called AC permanent magnet generator. However, the last one produces magnetic pole through electricifying the coil, so it is called AC excitation generator. Usually, the generator we talk about is AC flywheel generator.

According to the different rated voltage of battery, it can be divided into 6V battery and 12V battery. If the rated voltage is the same, according to the different volume, it can be divided into big and small. According to the different structure, it can be divided into plumbum acid battery and complete seal and maintenance-free battery.

#### [1]The Structure and Working Principle of DC Generator

DC generator works according to the principle of electromagnetism induction. Viz. when lead plumbs magnetic wire and moves in the well-proportioned magnetic field, there is inductive electromotive force produced in the lead. If the lead forms a closed circuit with other outer circuit, there is inductive electric current produced in the lead. The direction of this electric current can be estimated through right-hand rule.

#### [2]The Structure and Working Principle of AC Generator

AC generator mainly consists of AC flywheel generator, AC magnet rotor generator and AC three-phase generator. Like DC generator, it also works according to the principle of electromagnetism induction. But it doesn't produce electric current through the method that lead plumbs magnetic wire and moves in the well-proportional magnetic field. It produces inductive AC through the method that the rotor which made of permanent magnet rotates continuously and comes into being a rotating magnetic field, then makes magnetic wire continuously and alternately pass the fixed coil.

#### [3]The Structure and Working Principle of Storage Battery

This kind of storage battery has light weight, small bulk, good seal and shockproof performance. and the plumbum acid storage battery has small inner resistance and stable voltage. It mainly consists of battery body, cover, plate, electrolyte and clapboard. The battery body is made of hard rubber or plastic which is acidproof, heat-resistant and shock-proof. The battery is divided into 3 or 6 unattached parts according to the different stated voltage. There must be marked two marks outside the battery body. The upper mark is H and the lower one is L, which respectively indicate the upper limit and lower limit. Meanwhile, there are anode and cathode marked on battery. "+" is anode and "-" is cathode.

Plate is the main substance, where storage battery does chemistry of charging and discharging. It is made of plumbum antimony alloy pieces which are painted active substance and processed through electrochemistry. The plate is divided into anode plate and cathode plate. The active substance on anode plate is PbO<sub>2</sub> and on cathode plate is Pb.

Electrolyte is liquid mixed vitriol with distilled water. The temperature of electrolyte density for standard measurement is 20°C. When battery is at the standard temperature and in full charge condition, its density is between 1.24~1.29g/cm<sup>3</sup>. In each independent part of battery body, there is a set of plates and electrolyte installed inside. Each set of plates respectively does the chemistry with electrolyte, and makes up of an independent battery. Its voltage is about 2V. 3 or 6 batteries are series-wound and come into being a storage battery with the 6V or 12V voltage. The battery cover is made of high insulative hard rubber and hard plastic, which forms an integrated inner space with battery body.

[1] Remove fuse tube and check whether it melts down. Replace it with the same type.

Fuse tube type: 12V/20A

**CAUTION**

▶ When fuse tube is damaged, replace it with the same type.

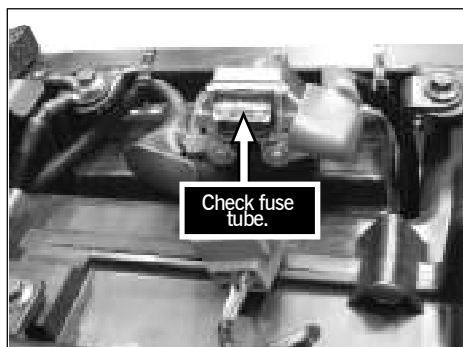

[2] Remove storage battery and measure whether its voltage is above 12V. When it's lower than 12V, remove and charge it.

**CAUTION**

- ▶ Screw down connecting bolt of storage battery when it is loose.
- ▶ Add distilled water when the electrolyte level of storage battery is lower than the lower limit mark.
- ▶ Keep away from fire while battery is charging. Because it will diffuse combustible and explosive gas during charging.

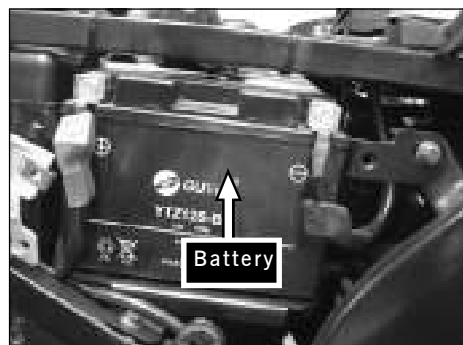

[3] Dismantle the socket of charging coil of generator and measure the charging coil with multimeter. Check whether the coil has short circuit. Replace it if short circuit.

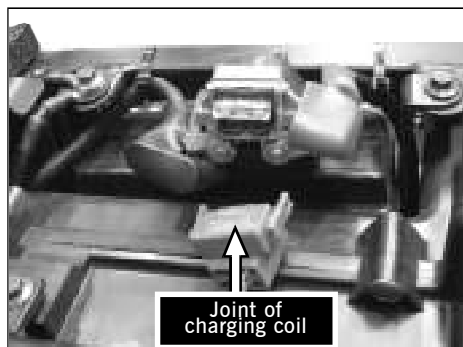

[4] Remove left cover of engine and the stator of generator. Measure the resistance of generator stator with multimeter and check whether the resistance has short circuit or open circuit. Replace it if short or open circuit.  
Resistance Value

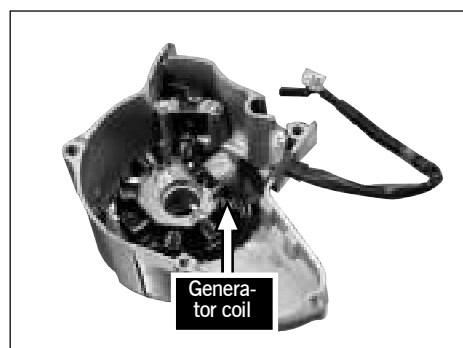



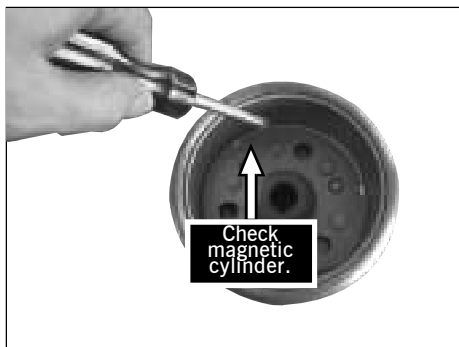

[5] Check whether the magnetic cylinder of generator rotor fades magnet. Replace magnetic cylinder if fades.

### 3 The cause, trouble description and repair method of power supply part

Table5-1 Maintenance of Power Supply Part

component description	cause	trouble description of component	trouble description of motorcycle	repair method
charging coil	short circuit	Battery has poor power.	Headlight cannot illuminate. Engine is hard to be started and poor engine power and unstable idle speed.	Replace charging coil.
	open circuit (limit value $\infty$ )	There is no spark spurt between piston electrode.	Engine cannot be started.	
generator rotor	distorted	no electric current export or poor export of generator	Engine is hard to be started or cannot be started. The electric power of motorcycle is not enough. Electroequipment cannot work normally.	Replace generator rotor.
	fades magnet	no electric current export of generator	Engine cannot be started. Headlight cannot illuminate.	
storage battery	damaged	no power	Starting motor doesn't run.	Replace storage battery.
	Storing time is too long.	Electric power is not enough and voltage is too low.	Starting motor doesn't run or runs feebly. Signal system is deviant.	Charge or replace storage battery.
	Electrolyte is not enough.	Electric power is not enough and voltage is too low.	Starting motor doesn't run or runs feebly. Signal system is deviant.	Add distilled water or replace storage battery.
fuse tube	Fuse tube is damaged or melts	no power	Starting motor doesn't run.	Replace fuse tube.

## Section 3 Control Part

### 1 Composing and Function of Control Part

In electrical system of motorcycle, control part is to ensure the good working condition of power supply part and power consumption part, and ensure their harmony. It can make rider control the electrical system momentarily.

Control part mainly consists of adjuster, rectifier, flash relay, starting relay, fuse tube, control switch and cable assembly.

#### (1) Adjuster

Adjuster is the important component of power supply part of motorcycle electrical system. It can be divided into DC generator adjuster and AC generator adjuster according to the engine type.

##### [1] DC generator adjuster

Because the voltage export of DC generator adjuster and the rev has direct proportion, it will bring some problems: [A] When motorcycle runs with high speed, the engine rev is very fast and the voltage export of DC generator is very high, which will easily make the electro-equipment burn out and make the storage battery over charge. [B] When motorcycle runs with low speed, the engine rev is very low, which makes storage battery export power to DC generator with strong electric current so that the DC generator is burned out. So it is necessary to make adjuster cooperate with generator.

##### [2] AC generator adjuster

The motorcycle with generator not only needs the rectifier to transfer the AC to DC, but also it needs AC adjuster to stabilize the export of generator. At present, the AC adjuster which is usually used is AC electronic adjuster.

AC adjuster mainly consists of transistor, diode and thyristor. When generator works, the lighting and signal coil will produce AC.

#### (2) Rectifier

Rectifier is normally divided into two types: single-phase half wave rectifier and full-wave bridge rectifier. These two rectifiers work as the principle of one-way electric character of silicon diode. It is like an electronic valve, which only allows one side electric current to go through.

#### (3) Flash Relay

Flash relay is called flasher. It is mainly divided into three types: thermal resistance, capacitance and transistor.

#### (4) Starting Relay

When starting electromotor works, the electric current will be very strong. It can reach tens of amp.

Starting relay is an electromagnetic switch. When pressing the starting switch of right handlebar, electric current will connect with the cathode of battery through storage battery, battery connection, relay coil and connection of starting switch, then it will make a closed circuit.

#### (5) Tube

Generally, fuse is composed of plastic fuse boxes fitted up with the fuse tube.

#### (6) Control Switch

The control switches of electrical system are centralized on the left and right handlebar. Normally, from up to down, there are switches of high/low beam light, turning light and horn on the left handlebar. Also, from up to down, there are switches of position light, headlight and electric starter on the right handlebar. The general electrical switch is in the middle of handlebar.

#### (7) Main Cable

Each part of electrical system of motorcycle is connected by lead. In order to avoid leads in a mess and be propitious to arrange on the frame, leads with the same direction are usually bound by insulative rubberized fabric. This is cable assembly.

### 2 Disassembly and Maintenance of Control Part

[1] Measure the voltage export of relay with multimeter and check whether it is within 13.0V~14.0V. Replace the voltage -adjusting relay when the voltage export is lower than 13.0V.

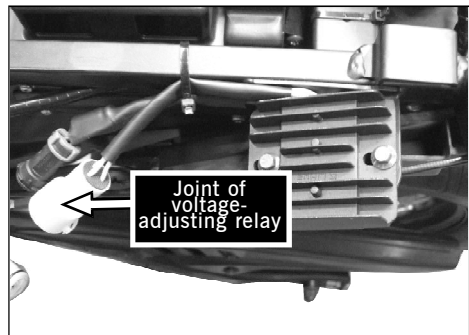

#### ⚠ CAUTION

▶ Replace the rectifier when the cooling fins of it are broken.

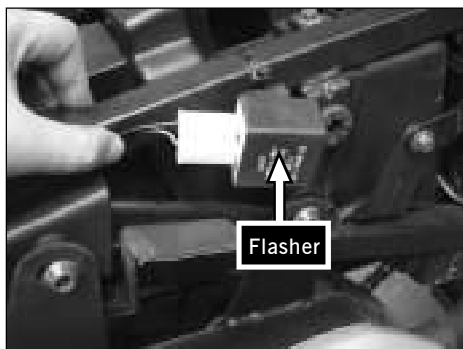

[2] Remove the flasher socket of signal system and measure the flasher with multimeter. Check whether it has short circuit. Replace it if short circuit.

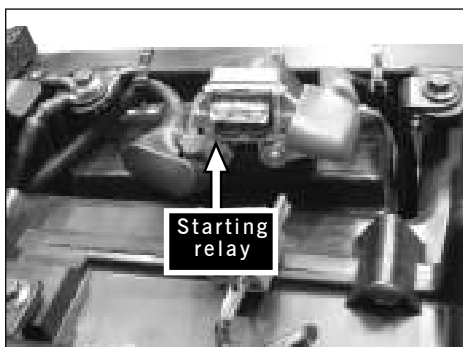

[3] Check whether starting relay is in good working condition. Replace it with the same type if it is not in good working condition.

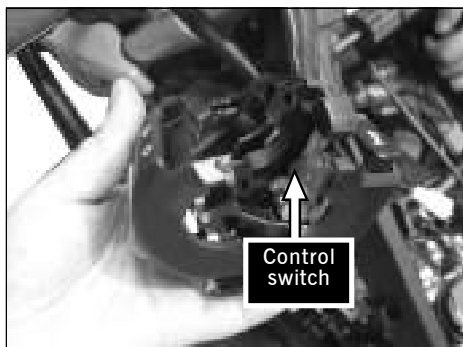

[4] Dismantle the switches of left and right controls. Check whether they are damaged or have short circuit. Repair or replace them if have problems.

**⚠ CAUTION**

- ▶ Check whether front/rear brake switches are in good working condition. Readjust or replace them if they are not in good working condition.
- ▶ If front/rear brake light do not shine when braking, then there is no electric power to start.

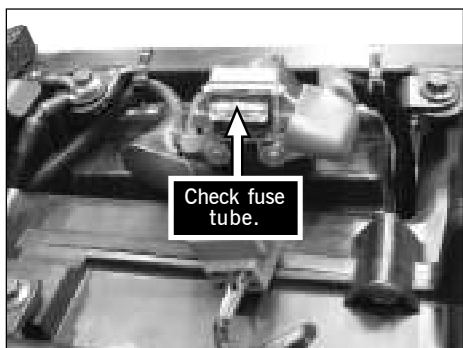

[5] Remove fuse tube and check whether it melts. Replace it with the same type.  
Fuse tube type: 12V/20A

**⚠ CAUTION**

- ▶ Replace fuse tube with the same type when it is damaged.

[6] Check whether the main cable is damaged. Bundle the leads in time if the insulative rubberized fabric is damaged.



### 3 The cause, trouble description and method repair of control part

Table 5-2 Maintenance of Control Part

component description	cause	trouble description of component	trouble description of motorcycle	repair method
rectifier	damaged	Rectifier has short circuit or open circuit.	Storage battery cannot be charged. Illuminating light illuminates dimly or cannot illuminate, and is easy to be burned out.	Replace rectifier.
starting relay	Inner coil has short circuit or open circuit. Inner connecting point is burned-out.	Starting motor doesn't work.	Motorcycle cannot be started with electric starter.	Replace starting relay.
		Starting motor runs feebly.		
starting button	Inner connecting point connects bad or is damaged. Inner connecting point is burned-out.	Starting motor doesn't work.	Motorcycle cannot be started with electric starter.	Replace button.
		Starting motor doesn't work or runs feebly.	Motorcycle cannot be started with electric starter.	Check storage battery.
fuse tube	Fuse tube is damaged or melts down.	no electric power	Starting motor cannot run.	Replace fuse tube.
illuminating/light-changing switch	Inner connecting point connects bad or is damaged.	Inner connecting point connects bad or is damaged.	Illuminating light is not in good working condition or cannot work.	Repair or replace illuminating/light-changing switch.
Direction indicator switch	Inner connecting point connects bad.	Inner connecting point connects bad or is damaged.	Direction indicator lamp doesn't illuminate.	Repair or replace direction indicator lamp.
flasher	The inner flasher is burned-out.	The inner flasher is burned-out.	Direction indicator lamp doesn't illuminate.	Replace flasher.
brake light switch	The inner connecting point cannot be returned or is damaged.	Brake switch cannot be returned or is damaged.	Brake light illuminates for a long time or doesn't illuminate.	Repair or replace brake light switch.
horn button	Inner connecting point connects bad or is damaged.	Inner connecting point of horn connects bad or is damaged.	Electric horn doesn't work or its sound is not normal.	Repair or replace horn button.

## Section 4 Power Consumption Part

The power consumption part of electrical system of motorcycle consists of following::

### (1) Light-signalling Device

Illuminating signal device consists of headlight, position light, taillight and meter indicator. Its main function is when motorcycle runs at night, they illuminate and have motorcycle noticed by other vehicles in order to ensure the riding safety.

Signal device consists of turning indicator, horn, gear indicator and brake light. It is used to indicate the running condition of motorcycle and express the operation of rider through sound and light signal.

### (2) Electric Starter Device

Electric starter device consists of starting motor and mesh setup. It is mainly used to start engine. (for the details, please refer to section 7, chapter 2).

## 1 Light-signalling Device

### (1) Headlight and Position Light

Headlight illuminates the front road for rider. It makes rider see the road condition and other running vehicles and also, it can send signal to the coming people and vehicles. Its flash can make the front vehicles noticed its overtaking intention. When motorcycle runs on a fog day, headlight is also usually opened to ensure its riding safety.

Position light is used to indicate the position of motorcycle and make motorcycle noticed by other people at a district where the illuminating condition is good or motorcycle passes other vehicles at night. It is usually installed in headlight assembly.

Headlight mainly consists of focus lamp, glass cover, bulb, lamp holder and cover.

The function of focus lamp is to make the light from bulb gather into a bright beam of light. Its material is aluminum board, which is made through pressing.

The main function of glass cover is to diffuse the beam of light which reflected by spotlight mirror and ensure front road to have enough area to be illuminated. It avoids making the coming drivers have the feeling of swimming.

Bulb is divided to single filament and double filament.

Bulb holder is made of galvanizing sheet iron after pressing. It is cylindrical. There are 3 uneven bulge at the edge of holder and there is a hole which lead can get through.

Lampshade and cover make up of a complete space, which contains the other parts of headlight.

### (2) Taillight and Brake Light

Taillight is used to indicate the position of motorcycle to the back vehicles when running at night and make the registration mark seen clearly.

Taillight mainly consists of lampshade, cover, lamp holder and bulb. The lampshade is made of red organic glass. There is transparent organic glass window embeded at lower part so that the registration mark can be illuminated.

The light cover is made of plastic. There are two side stands with holes at the bottom. The lampshade and light cover can be connected by screw.

### (3) Horn

During motorcycle running, rider can let horn make sound and make motorcycle noticed by passer-by and other vehicles to ensure running safety.

According to the different way of power supply, electric horn can be divided into AC electric horn and DC electric horn. This motorcycle adopts DC electric horn.

### (4) Turning Light

When motorcycle needs to turn, turning light will send out yellow flash signal through flash relay to make other people notice this motorcycle is going to turn. Normally, the turning light consists of cover, holder, bulb and lampshade.

## 2 Disassembly and Maintenance of light Signalling Device

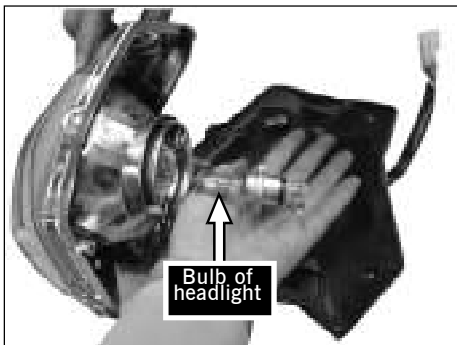

[1] Dismantle the cover of headlight and check whether the holder and bulb are in good working condition. Remove the bulb and check whether it is burned-out. Replace it with the same type if burned-out.

Bulb type: HS1 12V 35/35W

[4]Check whether the taillight is burned-out. Replace it with the same type if burned-out.



[3]Check whether the turning light is burned-out. Replace it with the same type if burned-out.

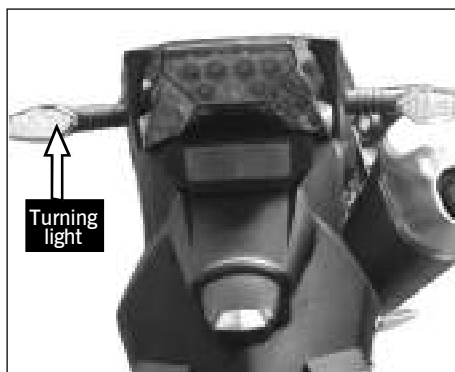

[4]Check whether the bulb of meter indicator is burned-out. Replace it if burned-out.



[5]When the sound of electric horn is hoarse and electric horn has no sound, adjust the horn volume according to the actual situation or replace the horn with the same type.

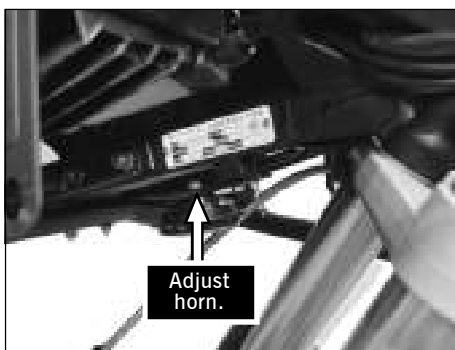

### 3 The cause, trouble description and repair method of power consumption part

Table5-3 Maintenance of Power Consumption Part

component description	cause	trouble description of component	trouble description of motorcycle	repair method
headlight assembly	The adjustment of beam of light is improper.	The beam of light of headlight is too far or too close.	—————	Adjust the beam of light of headlight.
	The filament of headlight is burned-out.	The filament of headlight is burned-out.	Headlight doesn't illuminate.	Replace the bulb of headlight.
taillight / brake light	The filament of brake light/brake light is burned-out.	The filament of brake light/brake light is burned-out.	The filament of brake light/brake light is burned-out.	Replace the bulb of brake light/brake light.
turning light	The filament is burned-out.	The filament of turning light is burned-out.	Turning light doesn't illuminate.	Replace the bulb of turning light.
gear indicator	The filament is burned-out.	The filament of gear indicator is burned-out.	Gear indicator doesn't illuminate.	Replace the bulb of gear indicator.
electric horn	The inner horn is burned-out or damaged.	The inner horn is burned-out or damaged.	Electric horn has no sound or the sound is not normal.	Replace electric horn.

## Chapter 5 Analysis of Motorcycle Troubles

### Section 1 Analysis of Engine Trouble

#### 1.1 Analysis of Poor Idle Speed of Engine

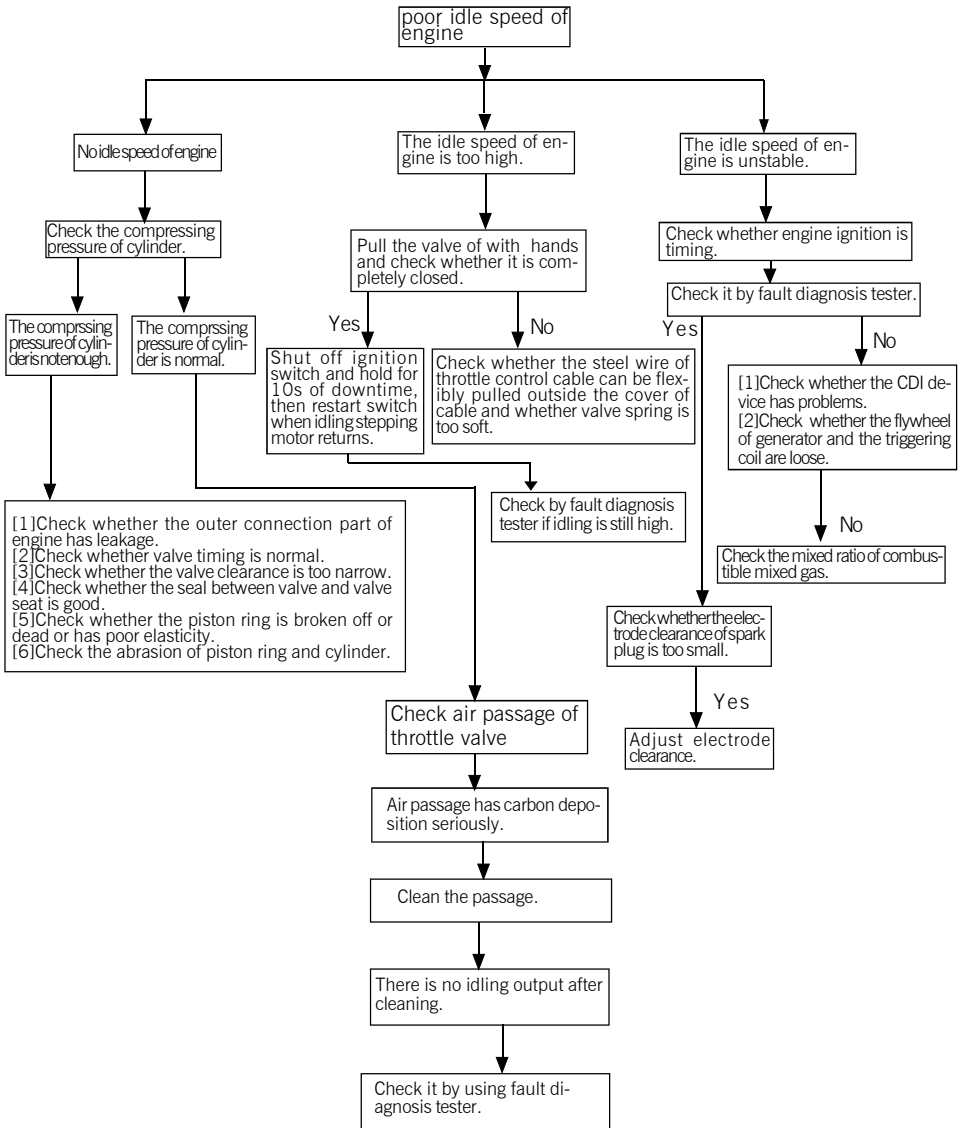



## 1.2 Analysis of Insufficient Engine Power

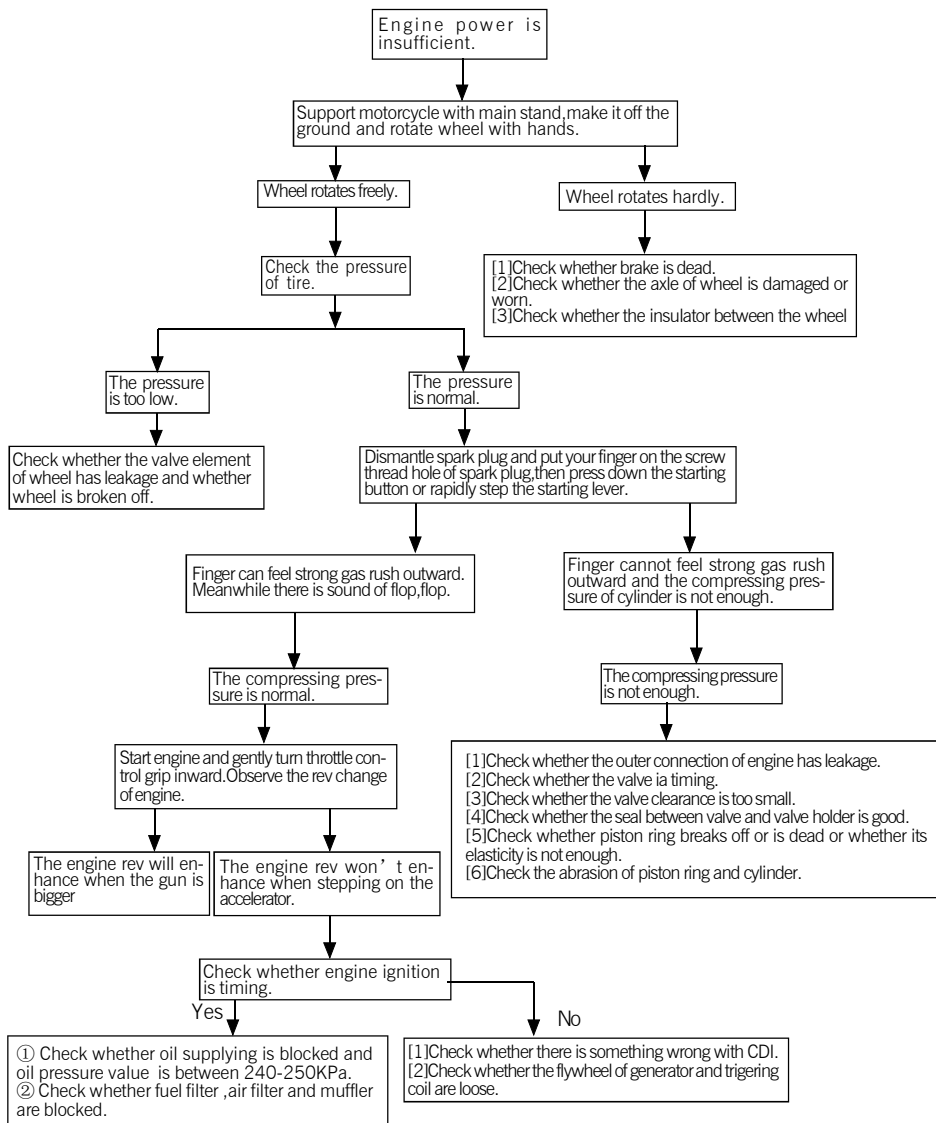

### 1.3 Analysis of Engine Start

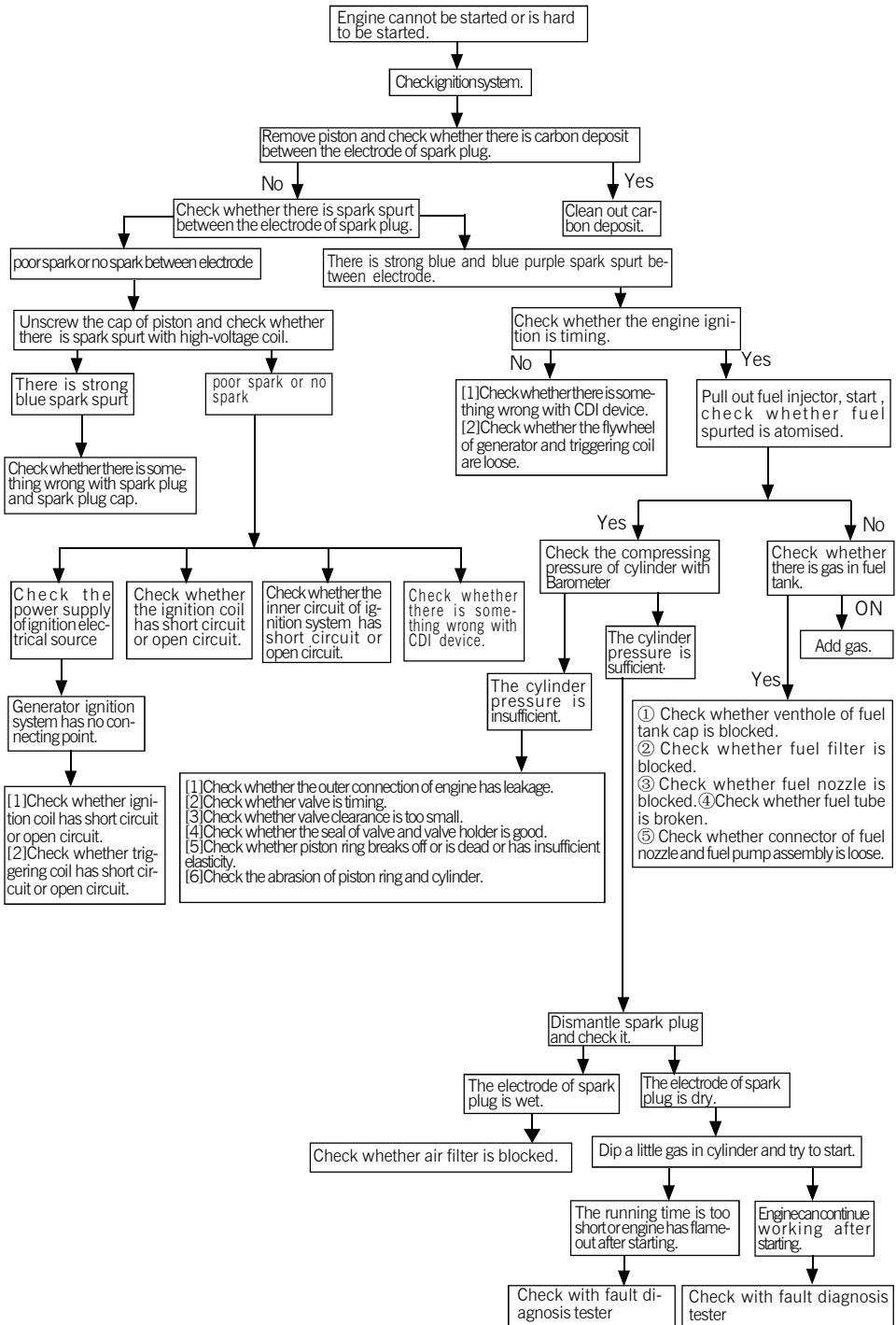



## 1.4 Analysis of engine overheating

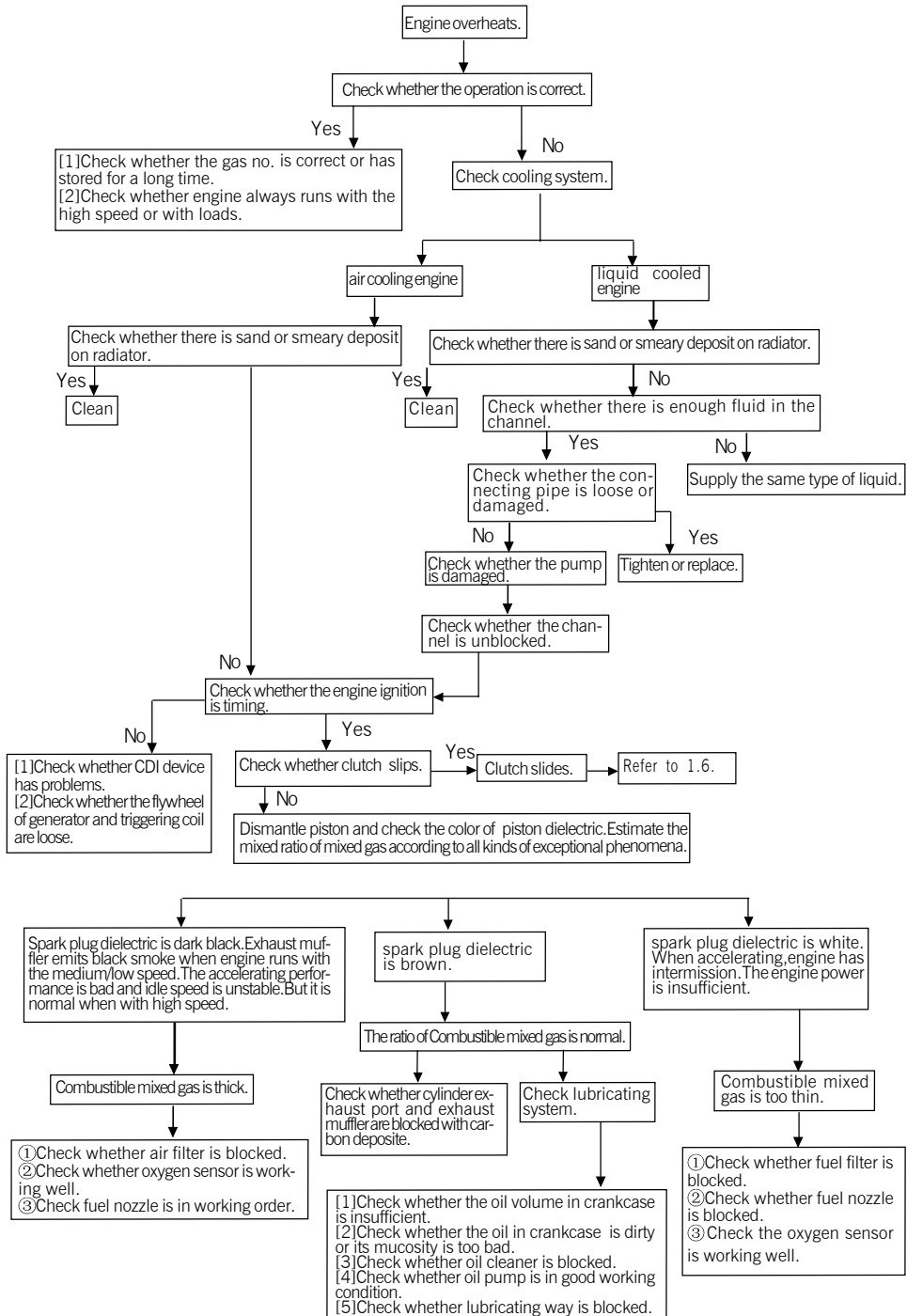

## 1.5 Analysis of over consumption of engine fuel

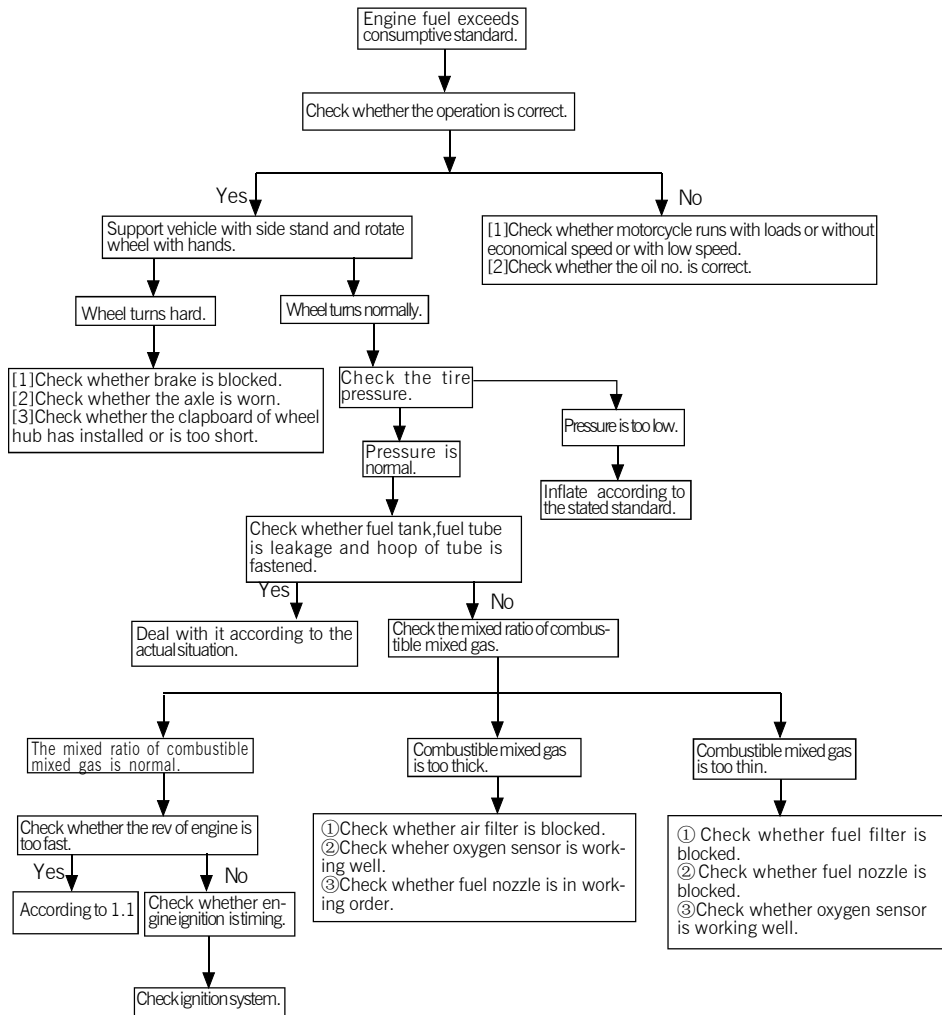

## 1.6 Analysis of exhaust muffler of 4-stroke engine

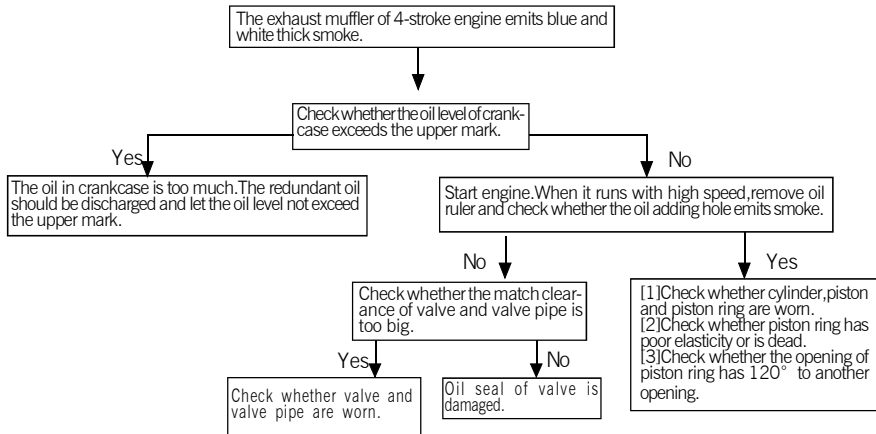

## 1.7 Analysis of gearshift

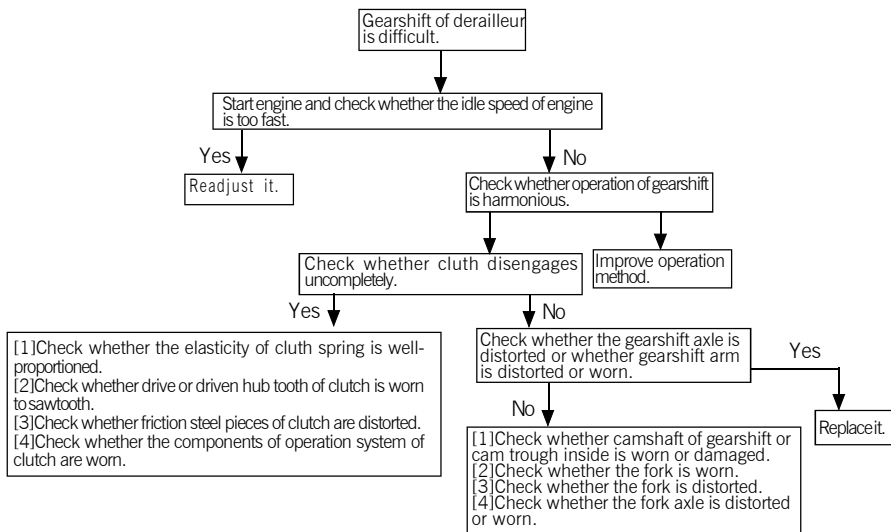

## 1.8 Analysis of derailleur gearshift

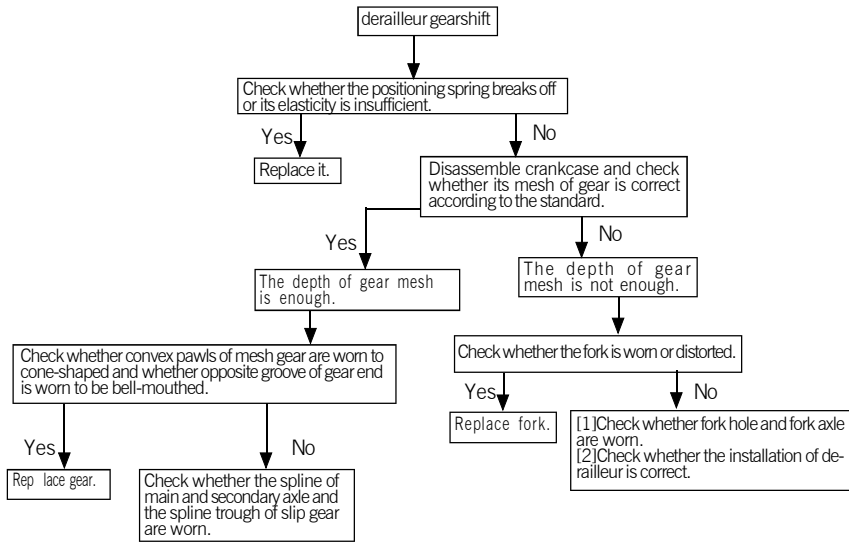

## 1.9 Analysis of slide and incomplete disengagement of clutch

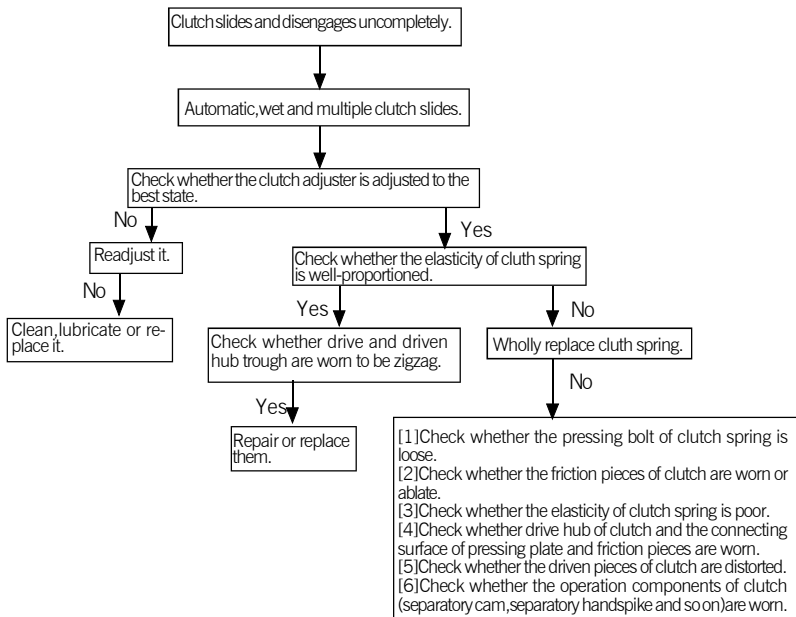

## Section 2 Analysis of electrical part

### 2.1 Analysis of battery

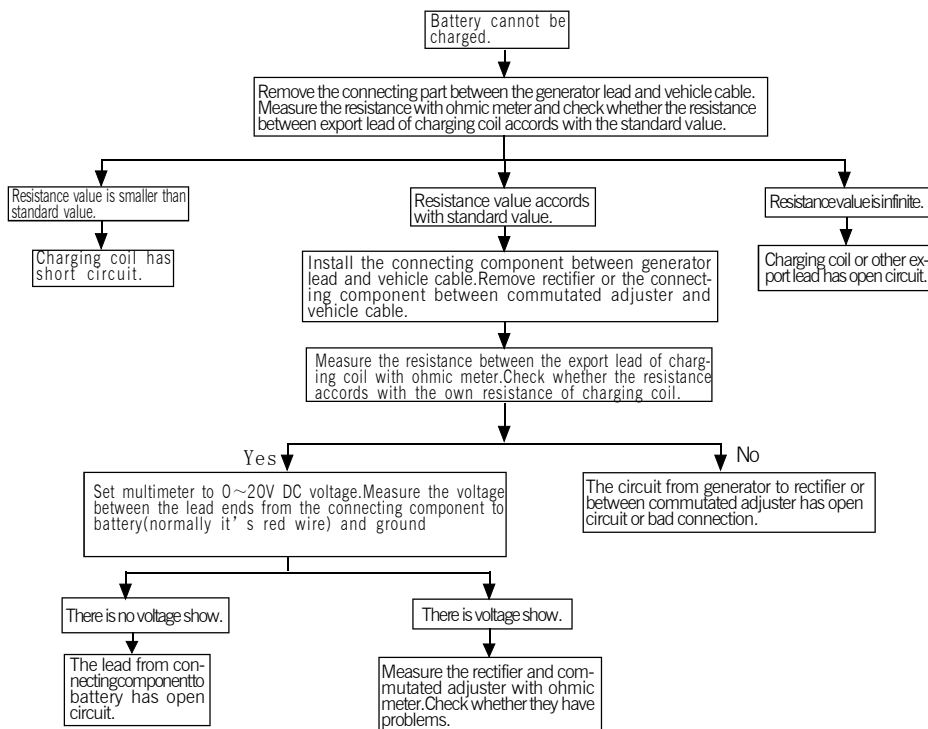

### 2.2 Analysis of battery

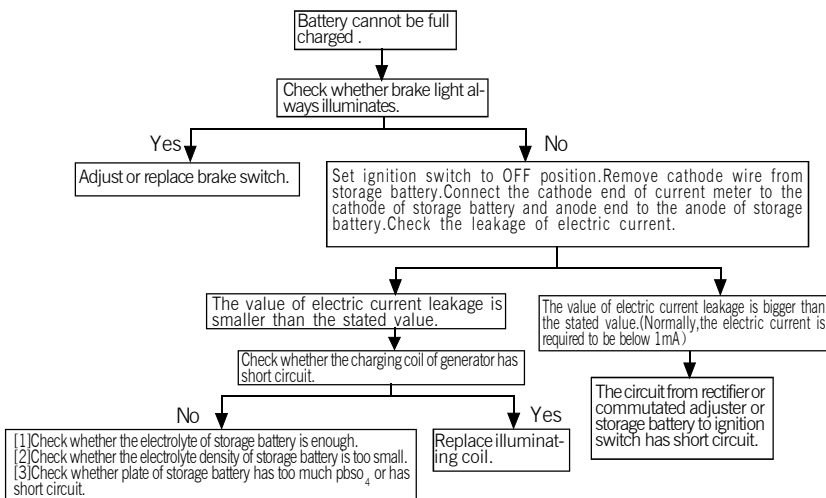

### 2.3 Analysis of starting motor

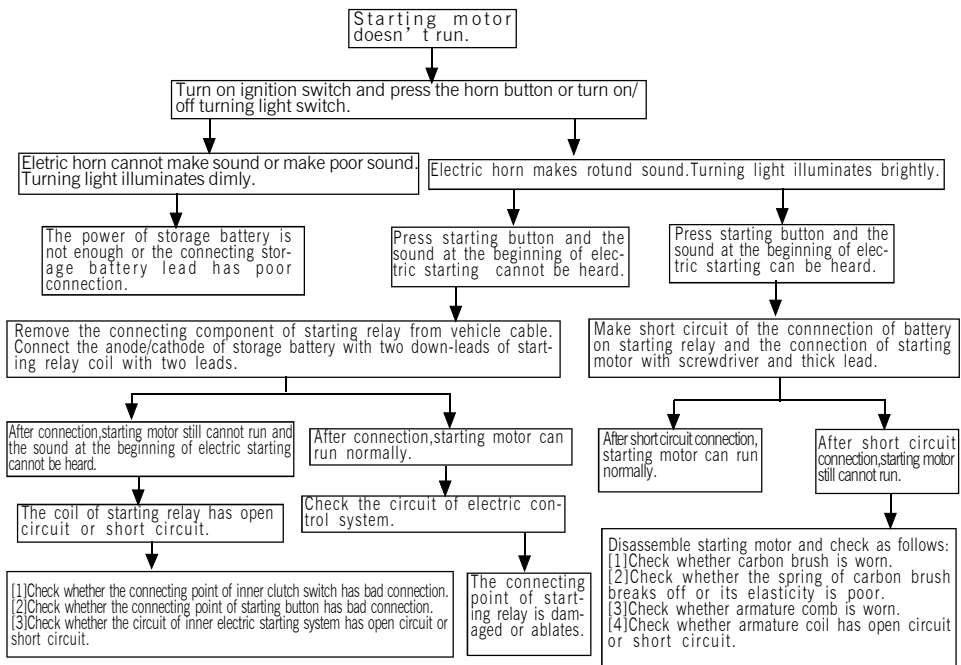

### 2.4 Analysis of starting motor

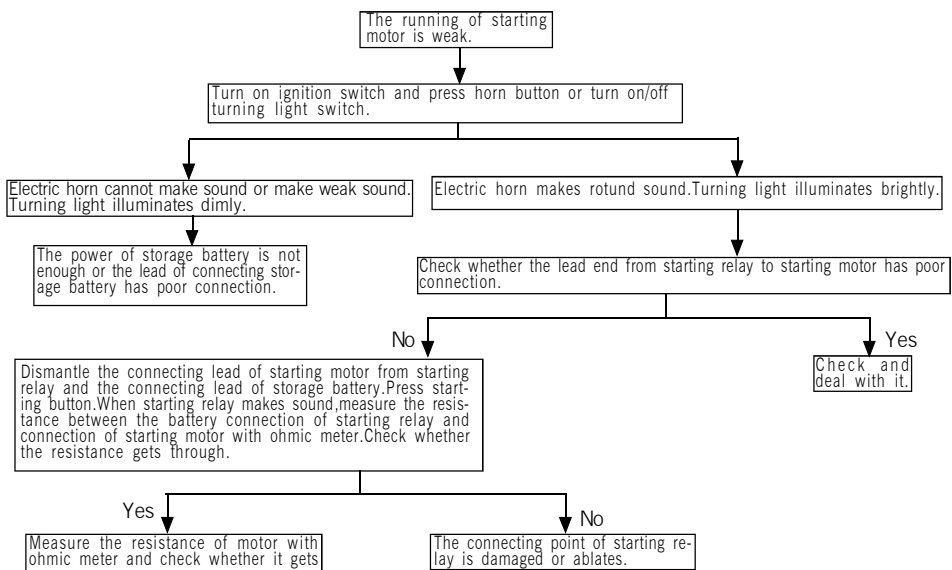



## 2.5 Analysis of illuminating light

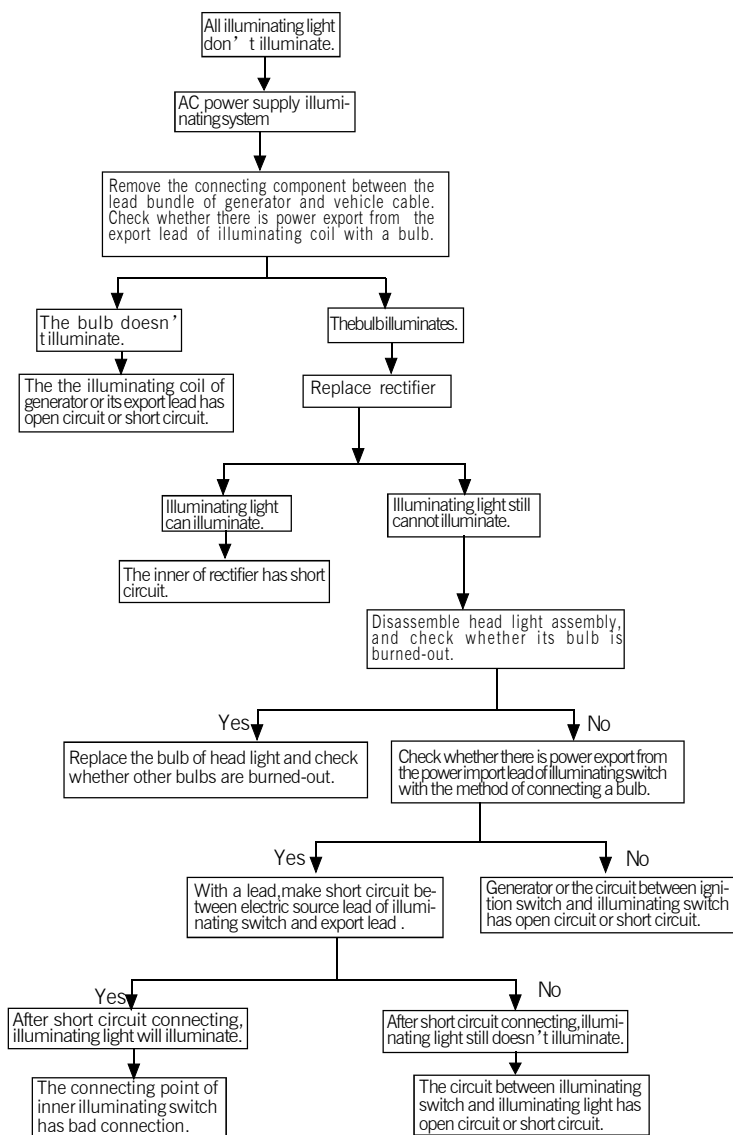

## 2.6 Analysis of illuminating light bulb

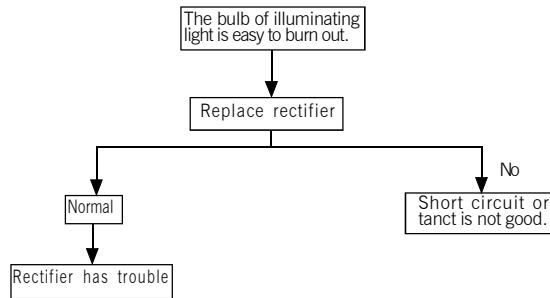

## 2.7 Analysis of illuminating light

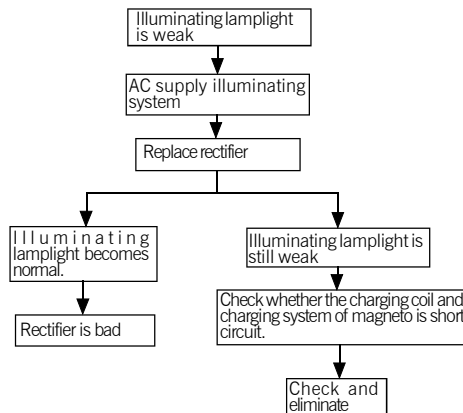

## 2.8 Analysis of turning light

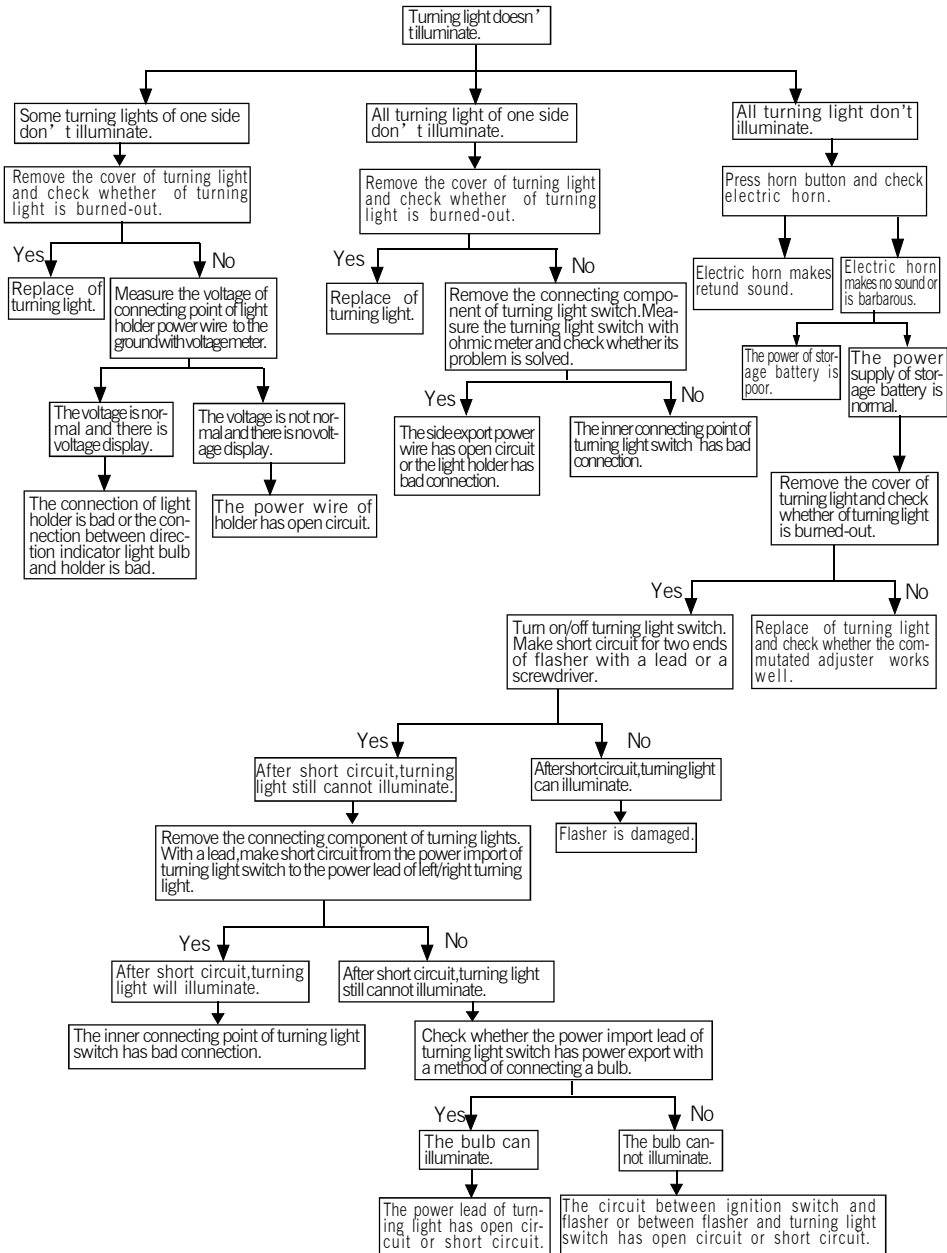

## 2.9 Analysis of electric horn

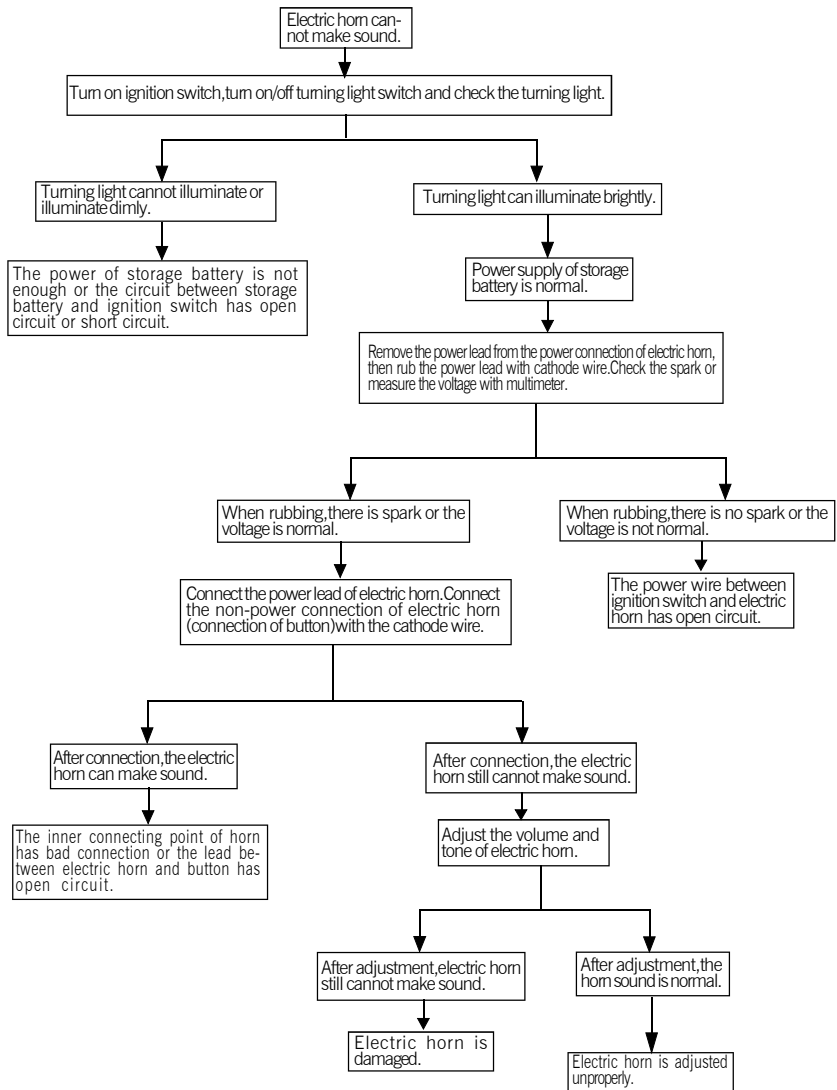

## 2.10 Analysis of brake light

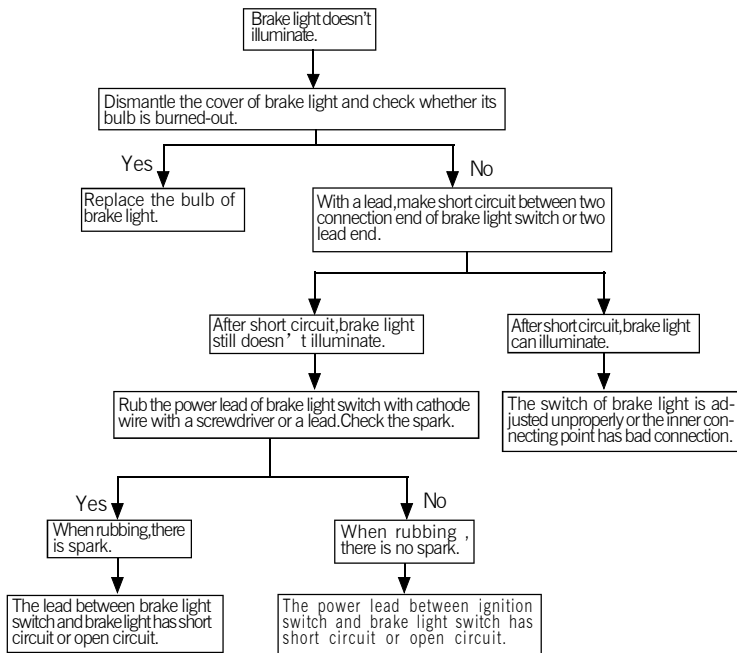

## 2.11 Analysis of ignition system

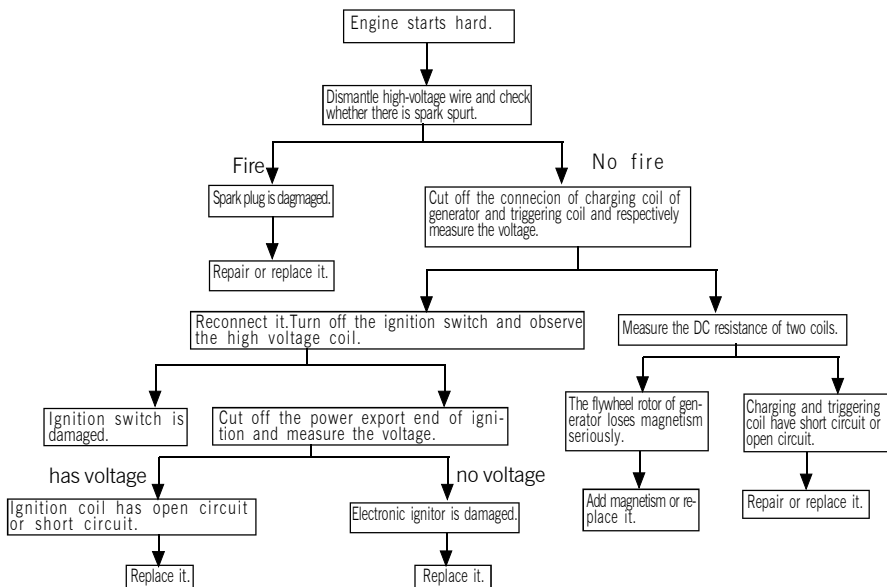

# APPENDIX CIRCUIT DIAGRAM

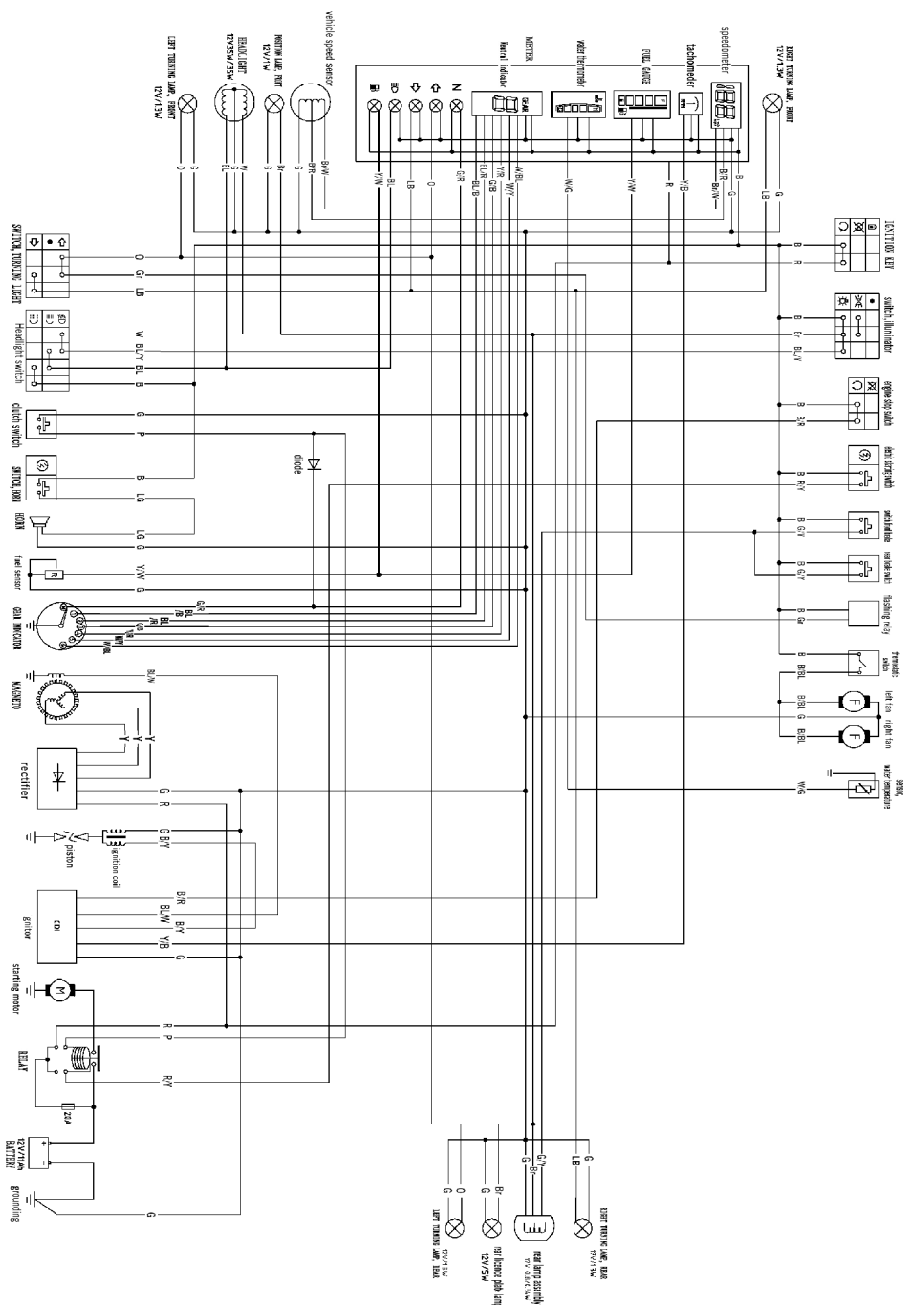

Copyright reserved by  
Zongshen group  
Format160mm × 230mm  
The 1st edition Aug,2013  
The 1st print Aug,2013



ZONGSHEN

ZONGSHEN MOTORCYCLE

CHONGQING ZONGSHEN MOTORCYCLE INDUSTRY MANUFACTURE CO.,LTD.

■ ADDRESS: CHAOYUOCHANG BANAN DISTRICT CHONGQING CHINA

■ SERVICE HOTLINE 4007903086