

USER'S MANUAL

MOTORCYCLES DAYTONA SERIES DD125E-5C DD350E-6C DD400E-6C

The engine of this motorcycle rotates at high speed. In order to make sure that the engine can run normally, prolong its service life and safeguard your interests, please operate the motorcycle according to the following regulations:

This manual including the following model

- DD125E-5C
- DD350E-6C
- DD400E-6C

Since this manual covers a few model and specification, the pictures listed are not covering all of the parts or spec, so please take the actual products as the standard.

CONTENTS

Safety driving through	2
Position of parts mounting.....	3
Function of parts	4-8
1.Lubrication	9
2.Tire pressure	9
3.Operating instructions.....	10
4.Repair and maintenance	11-16
5.Fault maintenance	17-18
6.Maintenance period table	19
7.Motorcycle main specs	20-24
8.Motorcycle electrical schematics	25

Motorcycle safety riding and &important notice PROTECTIVE APPAREL

A motorcycle rider ususally has his /her head injured in an accident. In order to ensure personal safety, the rider should wear a helmet, goggles, boots, gloves etc.The passenger should wear the same gear.

The temperature of the muffler is very high when the motorcycle is ridden. The passenger should wear boots or shoes high enough to cover his/her angles to prevent his/her feet from being scalded. The rider should wear close-fitting clothes to prevent loose clothing catching the handlebar, kick stand, footpegs and tyres.

ACCESSORIES

Accessories produced by our company have been under special design and test, and can render the motorcycle safe. They are optional for users. Users will take responsibility for their selection, installation and use of accessories not produced by our company. Please obey safe riding rules and follow the next points: Carefully check your accessories, make them out of sight line, reduce

distance between them and the ground and side up angle, and keep suspension or steering device from moving or affect handling. Avoid attaching any electrical equipment.Otherwise it can bring trouble to the electrical system.

ATTENTION

Proper use can extend the lifetime of the engine
Play a complete role of new bike function, please ride bike according to following requirements.

1. During the first 1000km, avoid full throttle and never labor the engine. The rotating speed of the engine should be strictly restricted to less than 6000rpm.
2. After the first 300 km, 600km and 1000km, please clean the engine and change. The engine oil in accordance with the requirements of operation and maintenance Manual.

Warning:

EFI model has fuel injection system replying on power.Please do not add extra equipment to cause the problem like default or distroy the ECU.

Motorcycle parts position

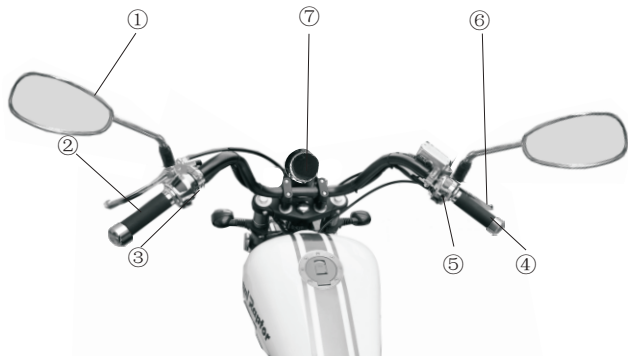

REAR MIRROR CLUTCH CONTROL GRIP
LEFT SWITCH THROTTLE GRIP RIGHT SWITCH
BRAKE LEVER ODOMETER



FUNCTION OF PARTS

IGNITION SWITCH

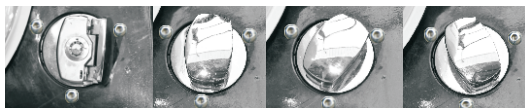

Switch at ① right side of chasis, pls open the switch cover first. Insert key,turn 90° at clockwise, the ignition switch can turn both sides, start the engine, the key can pull out any condition.

Ignition at position②: engine can not start with all routing shut off.

Ignition at position③: engine can start with all routing on Meanwhile all head light , tail light,etc are on. Odometer dial is bright.

Ignition switch turn to position ④ : engine can start , but position light and meter dial light is off. Kindly suggest you to switch the ignition to position 4 when start.

Headlock

headlock①is below the steering. Please turn to the very left,take out the key and turn at clockside, take out the key



①

Attention:

When lock the bike, please don't move orstart the bike

FUNCTION OF PARTS

ODOMETER

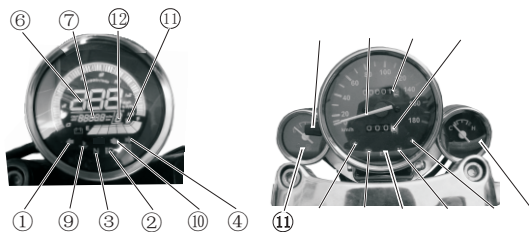

① Left indicator

switch to the left, it will flash when making a left turn.

high beam

high beam will be on by turning the switch to high beam

neutral light

when engine is in neutral, the N light will be on, and others are off.

right indicator

switch to the right, it will flash when making a right turn.

distance data resetting
anticlockwise the odometer handle, the distance data changes to 0.

speed

showing the km/hr,

odometer

it can grand total the number KM/miles, do not delete the numbers.

short distance data

for short distance purpose, it can be changed to 0.

water temperature indicator (except DD400E-6C)

Suit for water cooling model

it shows the temperature of water cooling. When it turns to the red, means the temperature is too high.

Warning:

When red light is on, please stop riding, check the fun, coolant is enough or not. please check the details until bike okay.

⑩ EFI warning light

EFI Bike valid

The EFI light is on when switched, it is off when start the engine. If the light still on, it means that the bike still have problem.

Please use the Diagnostic to check the failure code and solve it.

⑪ Fuel gage

For EFI bike

It shows the fuel in tank. If indicating below red line, please fuel the bike a.s.a.p.

Warning:

The EFI bike need enough fuel. otherwise few fuel will cause the fuel pump idling and destroy the fuel pump.

Left switch

horn

Press horn if you need to use it.

turning light switch

If you need to turn left, then move “ ← ” position , If you need to turn right, then move to “ → ” position. Move the arrow to the middle, then it is ,

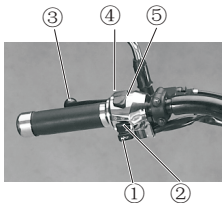

clutch controll handle

when you want to shift the gear, please hold the handle with grip hardly to seperate the clutch

If you wanna to start the engine, please pull the handle as well, then the bike can start up.

④ Overtake

If you want to overtake the others. Please press the high beam continuously for safety.

headlight changing switch

If you need dipped headlight, please switch to “ D ” position ; if you need high beam, please switch to “ D ” .

⑥ Choke handle

carburator version only.

Please dial down the choke handle, open the choke when starting the bike,

By starting the bike, please dial up the choke handle, close the choke.

Right handle switch(no AHO)

cutoff preset switch

“ ⊗ ” position : all circuit shut off engine can not start or cutoff the running engine.

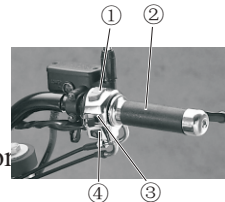

“○” : means the bike circuit on, you can start the engine. Please set the switch to “○” position.
throttle grip

adjust the throttle full-size , controlling the bike speed grip turning to rider yourself, it's accelerating. otherwise it's slowing speed.

headlight switch

It has three switches “” “” and “●”.

“” : headlight, taillight, odometer light are on

“” : front position light, tail light, odometer light are on.

“●” : front light, tail light, front position light, odometer light are closed.

power with electric press-button

1. Engine is in Neutral or in gears, grasp the clutch handle to separate the clutch disc.
2. key to the ignition switch, turn to “○” position.
3. cutoff switch to “ ” position, press power with electric button “” turn throttle grip, the engine can start

Right handle switch(EURO IV)

cutoff preset switch

“” position : all circuit shut off engine can not start or cutoff the running engine.

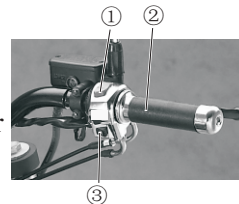

“○” : means the bike circuit on, you can start the engine. Please set the switch to “○” position.

throttle grip

adjust the throttle full-size , controlling the bike speed grip turning to rider yourself, it's accelerating. otherwise it's slowing speed.

power with electric press-button

1. Engine is in Neutral or in gears, grasp the clutch handle to separate the clutch disc.
2. key to the ignition switch, turn to “○” position.
3. cutoff switch to “ ” position, press power with electric button “” turn throttle grip, the engine can start

NOTE : EURO 4 AHO.

warning:

Every ignition less than 5s and 10s between twice. If failure, please check oil-way & system

REAR SHOCK

You can adjust the position please loose the locknut ①, loose or tighten the nut ②. adjust the spring tension, to tighten or loosen the rear suspension.

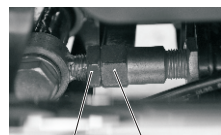

①locknut ②Adjust

please make sure the same tension

Fuel tank & tank cover

Open the cover, insert the ignition key turn right at 90 degree. You can open the cover. Press it when you want to close it and pull back&take out the key.

Fuel tank cover



Attention:

It's not well locked to pull out the key. Please do not extract it strongly forced.
please do not over fuel exceeding the neck of it. Please lock it when fully fueled.

Fuel tank switch

Suit for carburator models

☑ Turn on

please turn to this position, the fuel enters into the carburator smoothly.

☑ Spare

When normal fuel is used up, please handle this to use the spare.



● Close

☑ Turn on ☑ Spare ● Close

The whole fuel is closed by this position, Please close this fuel switch by long time riding.

Warning:

Please fuel the bike immediately when you start to use spares(only 2.7L), please turn on the switch after fueling it.

Fuel pump

Suit for EFI models

EFI fuel the bike using fuel pump Open the ignition lock, fuel pump runs 5 s. Stop working after 2-3 seconds. Pump always working after engine starts, It's destroyed by the pump idling. please pay attention to the fuel always.

Fuel pump assy.



Shifter

This engine has 5 gears internationally, The relationship chart please refer to following :



Lubrication fuction

lubrication oil is very important for engine lifetime, please forbid to use bad quality oil.

We suggest to use SAE15W / 40 API SJ oil. If you want to use others, the level need to reach above SG, the viscosity shows a rather pronounced variation with temperature. Please exhaust all lubrication in the crankcase and fuel the new lubrication oil,

Attention: :

Please send the used lubrication to the recycle bin. to avoid polluting the environment.

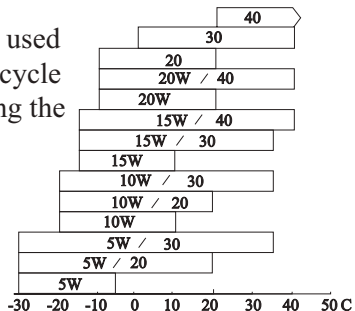

Tyre pressure

Correct tyre pressure can hold the best stable ride and comfort ride, make the tyre long time use.

Load	Pressure(Kpa)	Pressure(Kpa)
Rider	F.tyre:225	rear tyre:225
rider and passengers	front tyre:250	rear tyre:250

Please check the tyre pressure. Check its scratch, nail or others sharps when bike is not started. Check the tyre sunk or out of shape. If problem, please repair it or replace it immediately.

Please change tyre of following limits pattern

min.limit Deep pattern (mm)	
Front tyre: 1.5	Rear tyre: 2.0

Dangerous

It's dangerous to use over worn tyre, and effect stability, steering and operation improper pressure can cause the extra worn and cause accident, Less pressure can cause the damage or get out of rim and lead to accident.

Operation Guide

Engine grinding-in

New bike grinding in is 1000km

Please use only $\leq 3/4$ throttle to avoid over grinding in

Change gears oftenly to avoid continuously running at one RPM.

Control the engine RPM max. less than 6000r/min
Max. speed shall less than 55km/h during 500km;
during 500-1000km max speed shall less than 70km/h.

Keep fit after first grind. tighten all screws, adjust all parts, replace all polluted oil, examine the first 1000km to ensure the best status of your motorcycles, extend the life time of your engine.

Examination before ride

Take your few minutes to check your bike before usage, it can save the failure rate and guarantee the safety riding.

check level of engine lubrication if need, add oil, and check if it is oil leakage.

Check front, rear brake... Check & adjust the free route of brake, check braking function (locking or no braking)

Check tyre... check both tyre pressure and wear damage, please filling or fixing it

Check throttle control... check free route of grip to handle, cable connect, adjust it or change it if necessary.

Check lighting and signal... check front light, tail light, turning light and function of horn.

Adjust it if necessary.

Check drive chain... check its tension or lubrication, If seriously worn or damaged, please change it.

Check steering control mechanism... check its flexibility and stability, adjust it when necessary.

Check engine... check its noise or not

Check the coolant enough or not.

Warning:

Please don't start engine at narrow space to escape the pollution. Please forbid to start engine when engine is in gear. It can damage the engine parts or cause accident.

Ride

Heating up the engine gradually

1.To release clutch when engine idling,change gears to first gear position.

2.throttling engine speed,releasing clutch handle, coordinate these two steps for better starting.

3.when you ride the bike steady, disconnecting clutch, shifting to 2nd gear;please use the same way shifting to other speed.

Dangerous :

Please do not shift gears without holding hard clutch hand shank, otherwise it can cause the transmission chain damaged.

please do not shift to neutral when down hilling, you need to hold the bike by engine power.

Brake and park

Please reduce throttle until close for low speed Lowing speed by front&rear brake,hold clutch handle, shift to neutral, hold the bike and kick the stand up.

Before cornering please close the throttle&low it by brakes. Otherwise, you could not control it by sudden braking and cause the slide and turnover.

please pay attention to control bike evenly on wet road,If you accelerate it too much, the bike can be out of control

Check and keep in good repair

Oil level check

Please check the oil lever before running the bike. There is engine oil dipstick①backward the right crankcase to measure the lubrication level.

Please measure it after 5 minutes by stopping the engine. Please lay the bike vertical with the ground. Clean the dipstick, insert the dipstick into the oil, unlock screw, check the level.

Level is between②and③two means it is full of lubrication.

Level is under③, please add SAE 15W/40 API Sj engine oil to this top level.

Fit on the dipstick&check whether it is leakage



① Oil gauge

② upper calibration line
③ lower line



warning:

It leads to parts damage due to less oil. It effects the max.speed due to over oil.

Change lubrication oil

Oil by machinery running can be poured out thoroughly.

Set a suitable vessel for used oil under the engine, then open refueling cover and piston, release oil and lock the screw, Leaning the engine for 2-3 hours until used oil is all out, then add 1.8L new oil.

DD150E-2 add 0.9L new oil

Please strike the strainer then clean it.

Please reverse spring, take out the strainer by holding the pot head.

Please ensure the oil pump seal ring is well before fitting on the drain plug. Otherwise please change the seal ring to avoid leakage.

Spark plug

Take out plug cap, clean it, strike the spark plug by special spanner, Please clean its dirt by wire brush, check it damaged or not, fired by electrodes, if damaged, please change the spark plug.

check the clearance between side electrode ①, and adjust to 0.6-0.7mm.



drain plug



oil pump seal ring



strainer



side electrode

Check the spark plug seal gasket is ok.

Attention:

Please mount the spark plug by hand, then tighten it by the special spanner.

Pay attention to the dirt inside the engine during having the spark plug out.

How to choose spark plug

① low speed or winter time, electrode show black please choose type CR5HSA

② High speed or hot summer time, electrode shows white, please choose type CR7HSA

③ standard type is CR6HSA (original is CR6HSA)。

Air filter

The core is made by filter, please always check it to avoid blocking up by dirt and reduce the output power.

Disassemble the outer cover, loose every bolt ②, take out the air filter cover ①.

take out the locator, strike the core ③, install new core. please use new air filter core.

Install air filter with different step as above.



① ②



③

BATTERY

Please check its electrolyte always keep it between "UPPER" and "LOWER". If below "LOWER", please add distilled water to Upper. Forbid to add other liquid.

Check voltage of battery either UPPER LOWER end, charging it below 12.3V.

If you start the engine hard or meet the electricity failure due to lack of electrolyte, please examine it by local repair station.

Attention:

Check outtake and air drain of battery well connected.

Pls take off battery if you do not use bike long time. Please take out the negative first, store at ventilated place after charging.

Please clean the wiring terminal of battery oftenly, and ensure it is not loose.

Please use same battery spec as 12V9Ah

Red sheath wire to connect positive, black to negative. Please do not mix them.

Adjust of clutch lever

The free clearance is 10-20 mm by holding clutch handle and feeling the resistance. If you find the free clearance wrong, please adjust it as following steps:

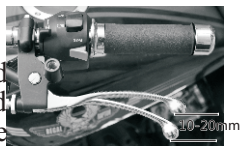

Loosen the locknut at crankcase clutch control plate bracket, adjust screw rod, turn according to (A), reduce travel of left handle; turn according to (B) side, increase free travel. Lock the top and bottom nuts after finishing adjustment.

Adjust screw rod at left switch can adjust the free travel. Loosen locknut, adjust the adjusting rod, locknut it when handle has enough free travel.

Adjust of throttle cable

check throttle grip flexible from open to close side.

Check if cable from throttle grip to carburetor well connected. If cable is wrenched cut or improper routing, you should replace cable. Check the grip idling free travel is between 2 ~ 6mm.

Please loosen locknut if it is adjusted,

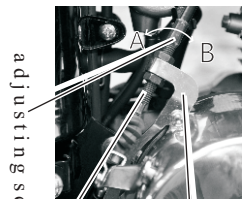

① locknut
② plate bracket



adjust pole
locknut



① locknut
② upper adjust coil

Then turn top adjust coil②、 still need adjust, loose nut a、 b adjust pole to 2~6mm free travel, lock adjust nut a、 b.

Adjust idle of carburator

Suit for carburator models

Heat the engine, operate it after high temperature.



WARNING:

you can not adjust EFI model since it is softwared

Check ,adjust &lubricate drive chain

Check the sprocket,chain

Check the pin of chain loose or not、 damaged on pin roller

Check rusty or dry up on chain ,

Check chain moving flexible ,

Check it over worn on chain and sprocket

Check teeth of sprocket damage

Check the loose of fixing bolt loose or not

Lubrication on chain

Dirty chain will wear the sprocket and chain more Please check regular date according to c h e c k l i s t "

Clean chain by detergent oil , after dry please add proper engine oil or chain oil .

attention :

ensure the open side of clip is opposite as normal running way .



Lock clip



④ ③ ②



Adjust on drive chain

Loose the rear axle nut②and drive chain adjuster locknut④, turn adjuster③by same adjusted dose.

Both adjusters should be same level, check the swing between 10~20mm Then tighten the rear axle nut.

Brake DISC

Brake disc will be worn after use. To ensure the proper braking and reliabity, please change it by max worn.

Max worn is 3mm.

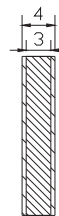

Disc Max worn limit

Adjustment on brake

Rear brake disc suitable

Holding motorcycle, test the pedal from update to free travel, it is 20–30mm.

If adjustment, loose the nuts ⑦, adjust the doble bolts⑧, increase or reduce pedal route and brake it several times,release brake, turn rear wheel checking its running, lock it.



Fuse box

Fuse replacement

please check fuse first when bike incorporation or cutoff.

Loose the cross screw on right cover when replacing. disassemble the right cover,open the fuse box you can replace it.

The rated fuse is 15A.

If you happens often burnout fuse, short circuit or overload. Please check with the local repair station.

Coolant

Suit for water cooling bike

Coolant is made by coolant and distilled water . freeze-proofing function It can reduce the engine temperature by circularly radiation of coolant .

The new bike is with coolant . Pleae pay attention to volume of coolant when maintaining You need to add if needed open water bottle cover , add coolant into water bottle until 80%

If coolant become muddy or time for maintain please change coolant .

Please follow the below steps . :

Stand the motorcycle at smooth ground .



Radiator cover①

Water bottle cover

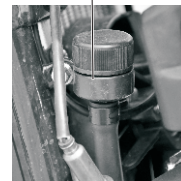

Checklist on braking system:

A:check the level of brake liquidcup

B:check leakage

C:check the cable leakage or crack

D:check worn of disc &friction plate

E:front brake lever free travel
5-10mm, rear brake foot bar free
travel is 20-30mm

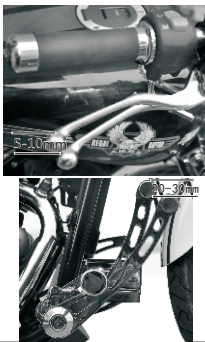

Attention:

Liquid disc brake pump is working under high pressure to ensure its safe, please do not change it exceeding.

Please maintain the braking system or disc brake to special appointed repair station.

Brake friction plate

Check if the friction plate is max worn .Please change it if exceeding

Attention:

Please do not ride it just after changing. Please run the front brake lever several time or rear foot bar, let the disc brake and caliper well cotact, function of braking sytem return to normal

Brake liquid

Check the liquid level of right handle switch and brake liquid cup. If it is few, please add the appointed brake liquid inside.

If the brake disc is worn, then the liquid will be auto matically flow into oil-pressure pipe.Check and fill in liquid is the most important item.

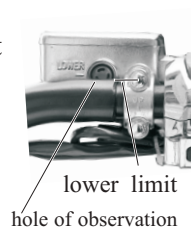

Danger:

Liquid has strong corrosive. Please disgorge it if you drink it,please wash it if it is in eye or on skin. And see doctor immediately.



Screw up the radiator cap , put fully coolant

Screw tightly after fitting on radiator cover .

Start the bike and idle it at 2 -3seconds open it cap again continuously add coolant Add tripe coolant , tighten it open water bottle cap put approx 400 ml coolant ,total volume is 1600ml

Attention :

When engine temperature reaches 125°C , odometer sense light on, means the engine need to have a rest, otherwise it will effect lifetime of engine.

Warning :

Please use 3500 anti-rusty antifreeze fluid coolant is harmful and corrosive. please do not drink it or infect with skin. Please recycle it to avoid pollution.

Please do not open the radiator cover, to avoid expulsion out and hurt people.

Please exhaust coolant by disassembly cylinder body when repairing engine, this can avoid it into crankcase.

Please check the leakage every 400km

water pump or circulating tube is leaked.

Press the tube to find if it has flaw and replace it.

Please contact maintainance people if leakage, Please do not open it by yourself.

Fault repair

Suit for carburator model

Please check out the reason if engine can not start :

1.Check if the fuel tank switch at open position .

2.Check if fuel is enough

3.Pull out the oil tube below fuel tank and check if fuel is outflowing

4.disassemble spark plug and connect ignition coil please put spark plug on unpainted hardware , press electric botton .If it has blue spark ,ignition system is fine .If no spark ,please go to the repair station and fix it .

Fault repair Suit for EFI model

Please check as following if engine can not start (EFI fault light no on) :

1.check the fuel indicator and ensure if you have enough fuel

2.Check if the battery connect is correct .

3.Check if the fuse is okay

Warning :

Start 3-5 minutes after replacing ECU,close ignition switch and re start

please shut down ignition switch when you want to pull out the EFI connector otherwise it will leave the historic record, you need to get rid of it by special diagnostic. please press the plug connector and pull out.

Clean

You should clean the motorcycle, and check its damage, wear and oil leakage or not.

Please do not clean the bike by high-pressure water to cause the damage. :

Ignition switch, electric switch, odometer, exhaust ex. fuel tank.

please avoid wet the exhaust, spark plug and battery
please use clean water to wash

Dry motorcycle, start engine by running few minutes.
lubricate the drive chain.

please test your brakes for good function before you ride out.

Motorcycle storage

You should do special check before your longtime storage.

1. clean and dry the motorcycle
2. exhaust the fuel in fuel tank and carburetor and have some antirust.

3. Take out the spark plug, put some (15-20ml) lubrication in cylinder body. Close ignition switch, press it several time again for more oil inside cylinder, please install spark plug again.

4. disassemble the battery and store it into well ventilate, dry shady place.

Attention: please close ignition switch, please disassemble negative wire first, then positive electrode; please fix positive first then negative, close ignition

switch when installation.

5. air the tyre to regular air pressure, stand it until front & rear wheel out of ground.

6. Please cover the motorcycle by cloth or breathability, save in the dry with good ventilation place.

Use it

1. Take off the cover, clean it.
2. check the voltage of battery, if it is below 12.3V, charge the bike then install battery.
3. get rid of antirust agents, add new fuel
4. test the bike carefully.

Daily maintain

Please clean it by cloth oftenly, dry the wet.
Put some antirust oil on chrome, put some wax on paint.

air the tyre according to pressure.
check every bolt and nuts to avoid falling down and cause accident.

Check the tyre and brakes flexibility, if it is over worn or damage, please change it.

Maintain chart

Please maintain the bike according to following symbols:

- *you can fix it by your self if you can
- **you need to go the maintain shop to fix it

Remark :

- ① Often clean it driving in dusty area
- ② if data is over max speed of odometer, please check details according to below details.
- ③ to adjust timing chain and valve clearanc, must be adjusted by authorized service shop for safety.

Times Period		period	Milage (km)			
			1000	4000	8000	12000
*	Fuel route		check	check	check	check
*	throttle system		check	check	check	check
*	carburator		↘	check	check	check
	core	Replace	check	check	check	check
	spark plug	4000km	check	check	check	check
	lubricate	first 500km, them 1000 km				
	filter net	clean it by placing the oil				
**	tention	adjust	check	check	check	check
**	valve clearance	adjust	adjust	adjust	adjust	adjust
	drive chain	c	check	check	check	check
**	rear brake		↘	check	check	check

times project period		times	maintance KM			
			1000	4000	8000	12000
	brake wear		check	check	check	
**	pipe	every 4 years	check	check	check	check
**	fluid cup		check	check	check	check
**	fluid	once every 2 years				
**	front brake		check	check	check	check
*	rear brake	per month	check	check	check	check
			check	check	check	check
	clutch	change friction disc	adjust	adjust	adjust	adjust
	hanger		check	check	check	check
	bracket		check	check	check	check
*	nut bolt	one month	check	check	check	
**	wheel/ tyre	3months	check	check	check	check
**	bearing	3months	check	check	check	check
**	coolant		check	check	check	check
**	fuel injector	clean every 30000km				

Remark : valid for all EFI modles.

DD125E-5C specification

Part	Item	Unit	Specification	Part	Item	Unit	Specification
Body	size	mm	2335×965×1100	Engine	Model		DD244MI
	wheel base		1660		type		Water cooling
	weight	kg	184		displacement	ml	125
	Max.load		150		min.fuel consuming	g/(kw-h)	340
	Max speed	km/h	≥90		compression ratio		10. 2: 1
	front tyre		90/90-21 225kpa		min.idle speed	r/min	1500±100
	rear tyre		160/80-16 225kpa		clearance of spark plug	mm	0. 6~0. 7
	fuel tank capacity	L	13. 5		Fuel type		RQ-93
	Ignition	L	EFI		Lubrication tyre		SAE15W/40 APE SJ
					Max Power(9500r/min)	kw	7. 8
			transmission type		five gears		
Electrical installation	front light		12V35W/35W	primary ratio		3. 833	
	F&R turning light		12V10/3W (12V10W)	1st ratio		2. 769	
	Tail light		12V21/5W	2nd ratio		1. 882	
	license plate		12V10W	3rd ratio		1. 450	
	spark plug		CR7HSA	4th ratio		2. 217	
	battery		12V9A. H	5th ratio		1. 083	
	fuse		15A	last ratio		2. 857	
	horn		12V 105dB	Cooling	Fan switch temp	°C	85
					sensor temp	°C	125
					cooling liquid capacity	L	1. 6
			cooling liquid type			3500 anti-cold	

DD350E-6C specification

Part	Item	Unit	Specification	Part	Item	Unit	Specification
Body	size	mm	2335×965×1100	Engine	Model		DD262MP
	wheel base		1660		type		Water cooling
	weight	kg	184		displacement	ml	320
	Max.load		150		min.fuel consuming	g/(kw-h)	340
	Max speed	km/h	≥130		compression ratio		10. 2: 1
	front tyre		90/90-21 225kpa		min.idle speed	r/min	1500±100
	rear tyre		160/80-16 225kpa		clearance of spark plug	mm	0. 6~0. 7
	fuel tank capacity	L	13. 5		Fuel type		RQ-93
	Ignition		EFI		Lubrication tyre		SAE15W/40 APE SJ
					Max Power(9500r/min)	kw	16. 8
			transmission type		5 gears		
Electrical installation	front light		12V35W/35W	primary ratio		3. 631	
	F&R turning light		12V10/3W (12V10W)	1st ratio		2. 846	
	Tail light		12V21/5W	2nd ratio		1. 777	
	license plate		12V10W	3rd ratio		1. 333	
	spark plug		CR7HSA	4th ratio		1. 083	
	battery		12V9A. H	5th ratio		0. 913	
	fuse		15A	last ratio		2. 286	
	horn		12V 105dB	Cooling	Fan switch temp	°C	85
					sensor temp	°C	125
					cooling liquid capacity	L	1.6
			cooling liquid type			3500 anti-cold	

DD400E-6C specification

Part	Item	Unit	Specification	Part	Item	Unit	Specification
Body	size	mm	2335×965×1100	Engine	Model		DD269FMQ
	wheel base		1660		type		Air cool
	weight	kg	184		displacement	ml	396
	Max.load		150		min.fuel consuming	g/(kw-h)	354
	Max speed	km/h	≥130		compression ratio		9.8: 1
	front tyre		90/90-21 225kpa		min.idle speed	r/min	1500±100
	rear tyre		160/80-16 225kpa		clearance of spark plug	mm	0.6~0.7
	fuel tank capacity	L	13.5		Fuel type		RQ-93
	Ignition		EFI		Lubrication tyre		SAE15W/40 APE SJ
					Max Power(9500r/min)	kw	19.8
			transmission type		5 gears		
Electrical installation	front light		12V35W/35W	primary ratio		3.631	
	F&R turning light		12V10/3W (12V10W)	1st ratio		2.846	
	Tail light		12V21/5W	2nd ratio		1.777	
	license plate		12V10W	3rd ratio		1.381	
	spark plug		CR7HSA	4th ratio		1.083	
	battery		12V9A. H	5th ratio		0.913	
	fuse		15A	last ratio		2.286	
	horn		12V 105dB	Cooling	Fan switch temp	°C	85
					sensor temp	°C	125
					cooling liquid capacity	L	1.6
			cooling liquid type			3500 anti-cold	

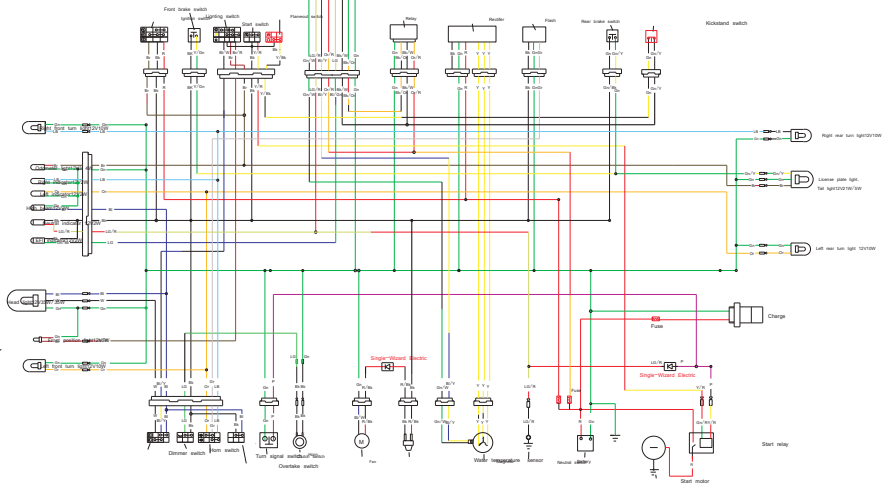
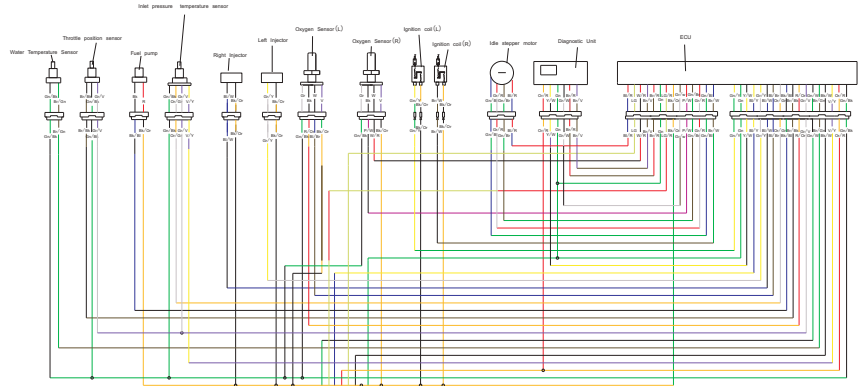

1	2	3	4	5	6	7	8	9	10	11	12	13	14	15	16	17	18	19	20	21	22	23	24	25	26	27	28	29	30	31	32	33	34	35	36	37	38	39	40	41	42	43	44	45	46	47	48	49	50	51	52	53	54	55	56	57	58	59	60	61	62	63	64	65	66	67	68	69	70	71	72	73	74	75	76	77	78	79	80	81	82	83	84	85	86	87	88	89	90	91	92	93	94	95	96	97	98	99	100
---	---	---	---	---	---	---	---	---	----	----	----	----	----	----	----	----	----	----	----	----	----	----	----	----	----	----	----	----	----	----	----	----	----	----	----	----	----	----	----	----	----	----	----	----	----	----	----	----	----	----	----	----	----	----	----	----	----	----	----	----	----	----	----	----	----	----	----	----	----	----	----	----	----	----	----	----	----	----	----	----	----	----	----	----	----	----	----	----	----	----	----	----	----	----	----	----	----	----	-----

