

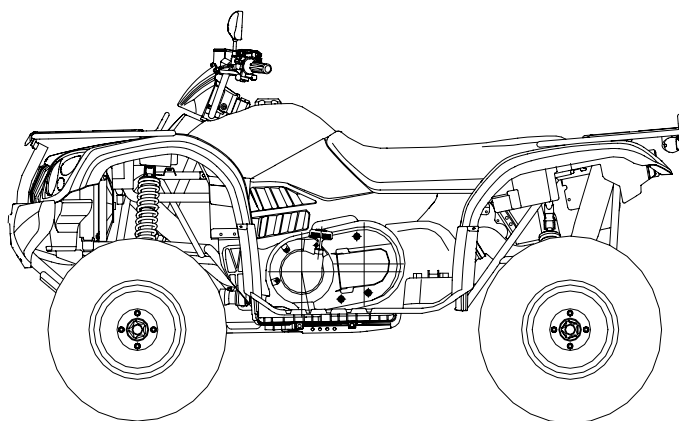

CF500/CF500-A

Service Manual



2006 By Chunfeng Holding Group Co. Ltd.

First Edition, August 2006

All Rights Reserved
Any reproduction or unauthorized use of this manual
without written permission of CFMOTO is
extremely prohibited

FOREWORD

This manual contains an introductory description of procedures for inspection, maintenance, overhaul, disassembly & assembly, removal and installation of components and parts, troubleshooting and service data together with illustrations of our All Terrain Vehicle Model CF500 and CF500-A

Chapter 1: general service information, tools, vehicle structure and technical data.

Chapter 3: key points for inspection and adjusting, service guide.

Chapter 2 and after Chapter 3: disassembly of parts and components, installation, overhaul and troubleshooting.

The manufacturer reserves the right to make improvements or modifications to the products without prior notice. Overhaul and maintenance should be done according to the actual state and condition of the ATV.

INDEX

Vehicle	
Service Information	1
Vehicle Body, Muffler	2
Inspection & Adjustment	3
Cooling System	4
Removal and Installation of Engine, Drive Train and Gearshift Unit	5
Front Wheel, Front Brake, Suspension, Steering	6
Rear Wheel, Rear Brake, Suspension	7
Battery, Charging System	8
Ignition System	9
Lighting, Instruments & Switches	10
Circuit Diagram, Wiring Diagram	11
Troubleshooting	12
Engine	
Engine Overhaul Information	13
Checks & Maintenance	14
Engine Removal, Inspection and Installation	15
Carburetor	16
Cooling and Lubrication System	17
Electrical System	18
Troubleshooting	19

Conversion Table

Item	Example	Conversion
Pressure	200Kpa (2.00kgf/cm ²) 33kpa(250mmHg)	1kgf/cm ² =98.0665kpa 1kpa=1000pa 1mmHg=133.322Pa=0.133322Kps
Torque	18N · m(1.8kgf-m)	1kgf · m=9.80665N · m
Volume	419ml	1ml=1cm ³ =1cc 1l=1000cm ³
Force	12N (1.2kgf)	1kgf=9.80665N

Cautions.....	1-1	Tightening Torque.....	1-10
VIN Number & Engine Number.....	1-4	Lubricant, Sealing Agent.....	1-11
Main Data Table.....	1-5	Cable Routing.....	1-12
Overhaul Data Table.....	1-6		

Cautions

Safety Cautions

1. Hazardous components in exhaust. Do not run the engine in a enclosed or poorly ventilated place for long time.
2. Do not touch the engine or muffler with bare hands after the engine has just stopped to avoid scalding. Wear long-sleeve work clothes and gloves for operation.
3. Battery liquid (dilute sulfuric acid) is highly caustic and may cause burns to skin and eyes. Flush with water if splashed to skin and get immediate medical attention. Flush with water if splashed to clothes to avoid burns. Keep battery and liquid away from reach of children
4. Coolant is poisonous. Do not drink or splash to skin, eyes or clothes. Flush with plenty of soap water if splashed to skin. If splashed into eyes, flush with water and consult the doctor. If drinking the coolant, induce vomit and consult the doctor. Keep coolant away from reach of children.
5. Wear proper work clothes, cap and boots. If necessary, wear dust-glass, gloves and mask.
6. Gasoline is highly flammable. No smoking or fire. Also keep against sparks. Vaporized gasoline is also explosive. Operate in a well-ventilated place.
7. When charged, Battery may generate hydrogen which is explosive. Charge the battery in a well-ventilated place.
8. Be careful not to get clamped by the turning parts like wheels and clutch.
9. When more than two people are operating, keep reminding each other for safety purpose.

Cautions for Disassembling and Assembling

1. Use genuine CFMOTO parts, lubricants and grease
2. Clean the mud, dust before overhauling
3. Store the disassembled parts separately in order for correct assemble.
4. Replace the disassembled washers, o-rings, piston pin retainer, cotter pin with new ones.
5. Elastic retainers might get distorted after disassembled. Do not use the loosened retainers.

6. Clean and blow off the detergent after disassembling the parts. Apply lubricants on the surface of moving parts. Measure the data during disassembly for correct assembling.
7. If you do not know the length of screws, install the screws one by one and make sure they are screwed in with same depth.
8. Pre-tighten the bolts, nuts and screws, then tighten according to the specified torque, from big to small and from inner side to outer side.
9. Check if the disassembled rubber parts are aged and replace if necessary. Keep the rubber parts away from grease.
10. Apply or inject recommended lubricant to the specified parts.
11. Use special tools wherever necessary.
12. Replace the disassembled ball bearings with new ones.
13. Turn the inner and outer rings of ball bearing to make sure the bearing will turn smoothly. Replace if the axial or radial play is too big. If the surface is uneven, clean with oil and replace if the cleaning does not help.
When pressing the bearing into the machine or to the shaft, replace the bearing if it could not be pressed tight.
14. Install the one-side dust-proof bearing in the right direction. When assembling the open type or double-side dustproof bearing, install with manufacturer's mark outward.
15. Keep the bearing block still when blowing dry the bearing after washing clean. Apply oil or lubricant before assembling.
16. Install the elastic circlip properly. Turn the circlip after assembling to make sure it has been installed into the slot.
17. After assembling, check if all the tightened parts are properly tightened and can move smoothly.
18. Brake fluid and coolant may damage coating, plastic and rubber parts. Flush these parts with water if splashed.
19. Install oil seal with the side of manufacturer's mark outward.
Do not fold or scratch the oil seal lip. Apply grease to the oil seal lip before assembling
20. When installing pipes, insert the pipe till the end of joint. Fit the pipe clip, if any, into the groove. Replace the pipes or hoses that cannot be tightened.
21. Do not mix mud or dust into engine and/or the hydraulic brake system.

22. Clean the gaskets and washers of the engine casing before assembling. Remove the scratches on the joint faces by polishing evenly with an oilstone.
23. Do not twist or bend the cables too much. Distorted or damaged cables may cause poor operation.
24. When assembling the parts of protection caps, insert the caps to the grooves, if any.

VIN Number and Engine Number

Vehicle Identification Number: LCELDTS~

Engine Number: CF188~



Engine Number

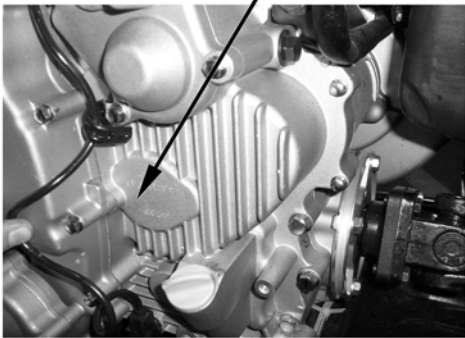

VIN Number



Main Data Table

Item		Parameter
Model		CF500/CF500-A
Length		2120mm/2320mm
Width		1170mm
Height		1230mm
Wheel base		1290mm/1490mm
Engine type		CF188
Displacement		493ml
Fuel type		Unleaded gasoline 90 Octane or above
Dry weight		337Kg/340Kg
Number of Passengers		1 for CF500, 2 for CF500-A (including driver)
Max. Load		150kg/225Kg
Tire	Front	25x8-12
	Rear	25x10-12
Ground Clearance		275mm
Min. turning diameter		4.5m/4.8m
Engine	Starting	Electrical starting/Recoil starting
	Engine type	Single cylinder, 4-stroke, Liquid-cooled, 4 valves, OHC
	Combustion chamber type	Triangle
	Valve Driving type	SOHC chain driving
	Bore x stroke	87.5mm X 82.0mm
	Compression Ratio	10.2:1
	Max. power	24Kw/7000 rpm
	Max. torque	36N.M/5500 rpm
	Lubrication type	Pressure & Splash
	Oil pump type	Rotor
	Oil filter type	Full flow filter screen
	Cooling type	Closed coolant circulation

Item		Parameter		
Fuel device	Air Filter type		Sponge element filter	
	Carburetor	Type	Vacuum Diaphragm type MIKUNI BSR36-89	
		Diameter of mixing valve	36mm	
Gearing	Clutch	Type	Wet, auto-centrifugal	
		Operation mode	Automatic (CVT) + Parking & Gear shifting	
	Initial Transmission	Gear type	Bevel gear	
		Reduction ratio	2.938	
	Secondary transmission	Gear type	Bevel Gear	
		Reduction ratio	2.938	
	Gearbox	Type	Automatic (CVT) + Parking & Gear shifting	
		Function	Auto-centrifugal	
		Transmission ratio	2.88~0.70	
		Gear Ratio	Final Ratio	1.333 (24/18, bevel gear)
			Secondary Ratio	1.952 (41/21)
Gears		Low Gear: 2.25 (36/16), High Gear: 1.35(27/20), Reverse Gear: 3.828		
Total	Low Gear: 5.857, High Gear: 3.514, Reverse Gear: 3.828			
Steering device	Steering angle	Right	30°	
		Left	30°	
Brake type		Front	Hydraulic Disc	
		Rear	Hydraulic Disc	
Bumper Device	Suspension	Swing Arm		
Frame type			Welded steel tube and plate	

Overhaul Datasheet

Lubricating device

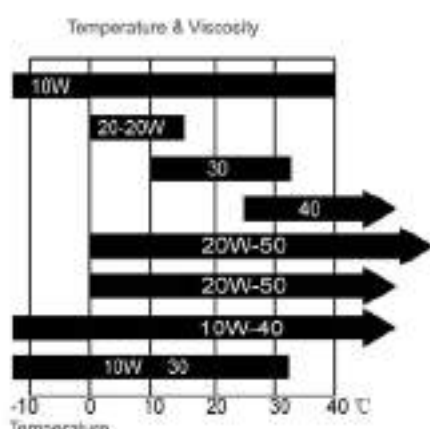
Item		Standard	Service limit
Engine Oil Capacity	Volume when replacing	1900m/	—
	Full capacity	12200 m/	—
Recommended Oil (see original)		<ul style="list-style-type: none"> ●Specially for 4-stroke motorcycle SAE-10W-40、20W-50 Substitutes must be used in the following range. ●API type: SE or SF grade ●SAE type: Choose from the left chart according to the environmental temperature 	
			
Oil pump Rotor	Gap between inner and outer rotors	0.07~0.15mm	0.20mm
	Gap between outer rotor and body	0.07~0.17mm	0.25mm
	End face gap	0.05~0.10mm	0.12mm

Fuel Device

Item		Standard
Fuel Tank Capacity	Full capacity	19.0/
Carburetor	Type	MIKUNI BSR36-89
	Main jet	N102221-130#
	Idle jet	N224103-22.5#
	Idle speed	1300±100r/min

Cooling Device

Item		Standard
Coolant capacity	Full Capacity	1140m/
	Reservoir tank capacity	340m/
	Standard density	30%
Opening pressure of radiator cap		108kpa(1.1kgf/cm ²)
Thermostat	Temperature / valve open	72±2C°
	Temperature/valve full open	88 C°
	Overall lift	3.5-4.5mm

Front Wheel

Item		Standard	Service Limit	
Front Wheel	Play of wheel rim	Vertical	1.0mm	2.0mm
		Horizontal	1.0mm	2.0mm
	Tire	Groove	--	3.0mm
		Pressure	35kpa(0.35kgf/cm ³)	--

Rear Wheel

Item		Standard	Service Limit	
Rear wheel	Play of wheel rim	Vertical	1.0mm	2.0mm
		Horizontal	1.0mm	2.0mm
	Tire	Groove	--	3.0mm
		Pressure	35kpa(0.35kgf/cm ³)	--

Brake System

Item		Standard	Service Limit
Front brake	Brake lever play	0mm	--
	Brake disc thickness	3.5mm	4mm
Rear brake	Brake lever play	5-10mm	--
	Brake Pedal Play	0mm	
	Brake disc thickness	7.5mm	6.5mm

Battery、Charging System

Item		Standard	
AC magneto Motor	Model	Permanent magnet AC type	
	Output	3- phase AC	
	Charging coil Resistance (20°C)	0.2-0.3Ω	
Rectifier	Three-phase annular rectification, Silicon controlled parallel-connected regulated voltage		
Battery	Capacity		12V18Ah
	Terminal point voltage	Fully charged	12.8V
		Insufficient charge	<11.8V
	Charging current/time	Standard	0.9A/5~10H
Quick		4A/1H	

Ignition system

Item		Standard
Ignition		CDI ignition
Spark Plug	Type	DPR7EA-9(NGK)
	Optional	DR8EA, D7RTC
	Spark plug gap	0.8-0.9mm
Ignition timing	Max. advanced angle	32° CA
Peak voltage	Ignition coil	Above 200V
	Pulse generator	150V

Light、Instrument 、 Switch、 Pickup coil

	Item	Standard
Fuse	Main	20A
	Auxiliary	10A 15Ax3
Light, Bulb	Head light (Hi/Lo)	12V-35W/35W
	Brake light/tail light	12V-21W/5W
	Turning light	12V-10Wx4
	Dashboard indicator light	12V-1.7W
	Other indicators	12V -3.4W

Tightening torque

Item	Torque N·m(kgf·m)	Item	Torque N·m(kgf·m)
5mm Bolt, nut	5(0.5)	5mm Screw	4(0.4)
6mm Bolt, nut	10(1.0)	6mm Screw	9(0.9)
8mm Bolt, nut	22(2.2)	6mmSH Bolt with flange,	10(1.0)
10mm Bolt, nut	34(3.5)	6mm Bolt with flange, nut	12(1.2)
12mm Bolt, nut	54(5.5)	8mm Bolt with flange, nut	26(2.7)
		10mm Bolt with flange, nut	39(4.0)

For others not listed in the chart, refer to the standard tightening torque.

Notes: 1. Apply some engine oil on the part of screw thread and contact surface.

Item	Thread Dia. (mm)	Quantity	Torque N·m(kgf·m)
Front Upper Bolt, Engine	M8x60	1	35~45
Rear Upper Bolt, Engine	M10x1.25x110	1	40~50
Front Upper Bolt, Engine Bracket	M8x14	1	35~45
Rear Upper Bolt, Engine Bracket	M8x14	1	35~45
Lower Mounting Bolt, Engine	M12x1.25x140	2	50~60
Bolt, Swing Arm	M10x1.25x70	16	40~50
Bolt, Rear Absorber	M10x1.25x50	4	40~50
Bolt, Front Absorber	M10x1.25x50	4	40~50
Bolt, Rear Wheel Support	M10x1.25x100	4	40~50
Mounting Nut, Rim	901-07.00.02 M20	16	50~60
Nut, Rim Shaft	901-07.00.03 M10	4	110~130
Mounting Screw, Rear Brake Pump	M6x25	2	18~22
Bolt, Rear Brake Caliper	M10x1.25x20	2	40~50
Bolt, Front Brake Disc	901-08.00.03 M8	8	25~30
Bolt, Front Brake Caliper	M8x14	4	35~45
Bolt, Handlebar	M8x55	4	20~30
Nut, Tie-rod	M10x1.25	4	40~50
Locknut, Steering Stem	M14x1.5	1	100~120
Rear Mounting Bolt, Muffler	M8x30	1	30~50
Bolt, Exhaust Pipe	M8x14	1	30~35
Mounting Bolt, Muffler	M8x40	1	30~35
Mounting Bolt, Rear Axle	M10x1.25x110	2	40~50
Mounting Bolt, Front Axle	M10x1.25x90	1	40~50
Mounting Bolt, Front Axle	M10x1.25x25	2	40~50
Bolt, Front Axle Support	M8x14	2	35~45
Bolt, Rear Transmission Shaft Rear End	901-30.00.01	6	40~50
Bolt, Rear Transmission Shaft Front End	901-29.00.01	4	35~45
Bolt, Front Transmission Shaft	901-29.00.01	8	35~45
Thermoswitch	CF250T-420500	1	28~30
Bolt 1, Front Rack	M8x14	2	35~45
Bolt 2, Front Rack	M6x12	2	25~30
Bolt, Rear Rack	M8x14	4	35x45

Lubricant, Sealing Agent

Application Areas	Cautions	Lubricants & Grease
Oil Seal Lip, Steering Stem Pivot, Rear Brake Pedal Joints, Throttle Cable Throttle Lever		Multi-purpose Lubricating Grease
Dust-proof Seal Lip, Front Shock absorber		#5 Absorber Oil
Inner surface, Handlebar		Engine Oil

Cable Routing

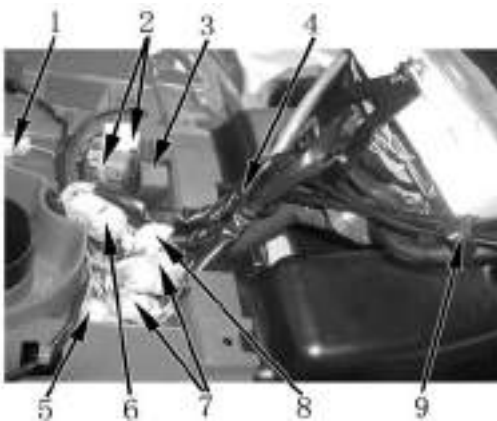
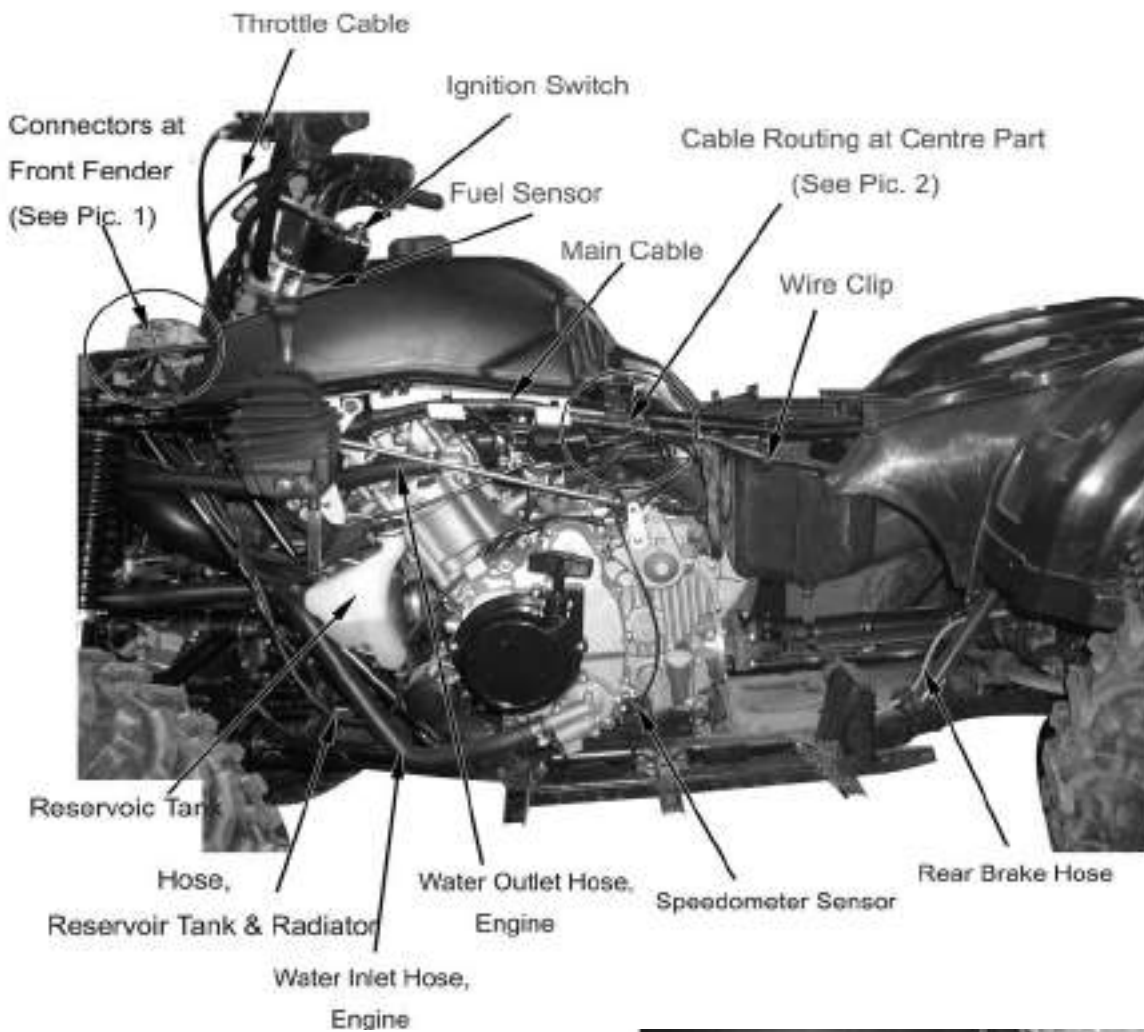

- | | |
|--------------------------------------|-------------------|
| 1. Connector, Fan Motor | 2. Connector, CDI |
| 3. CDI | 4. Wire Clip |
| 5. Connector, Starting Switch | |
| 6. Connector, Dashboard | |
| 7. Connector, Handlebar Switch (L&H) | |
| 8. Connector, Ignition Switch | |
| 9. Wire Clip | |



- | | |
|---|----------------------------------|
| 1. Ignition Coil | 2. Water Temperature Sensor |
| 3. Cable, Parking | 4. Breather Hose, Reservoir Tank |
| 5. Vacuum Tube | 6. Wire Clip |
| 7. Connector for Magneto, Gear Sensor and Pickup Coil | |
| 8. Fuel Pipe, Carburetor | |
| 9. Wire, Starting Motor | |
| 10. Steel Wire Clip | |

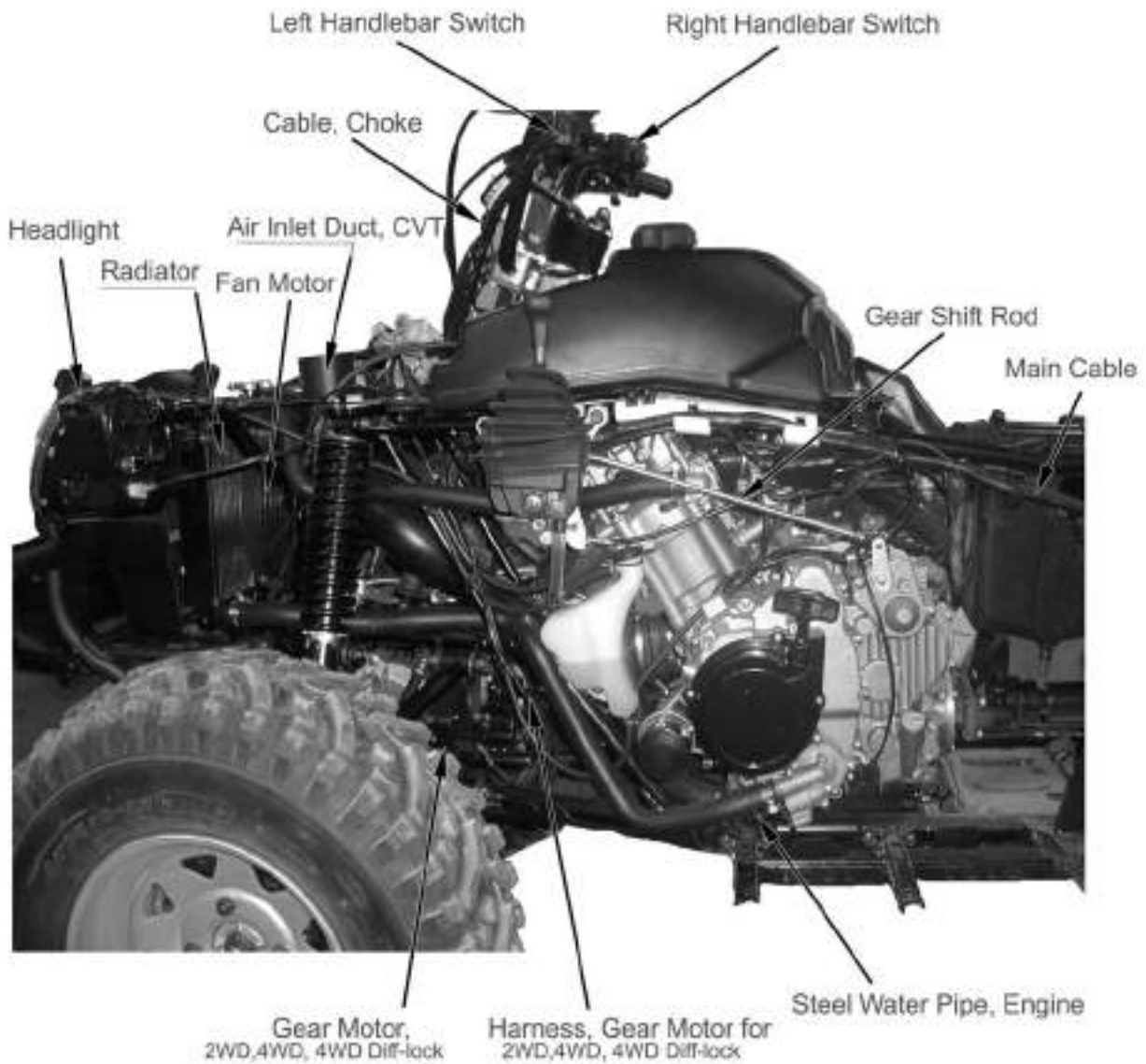

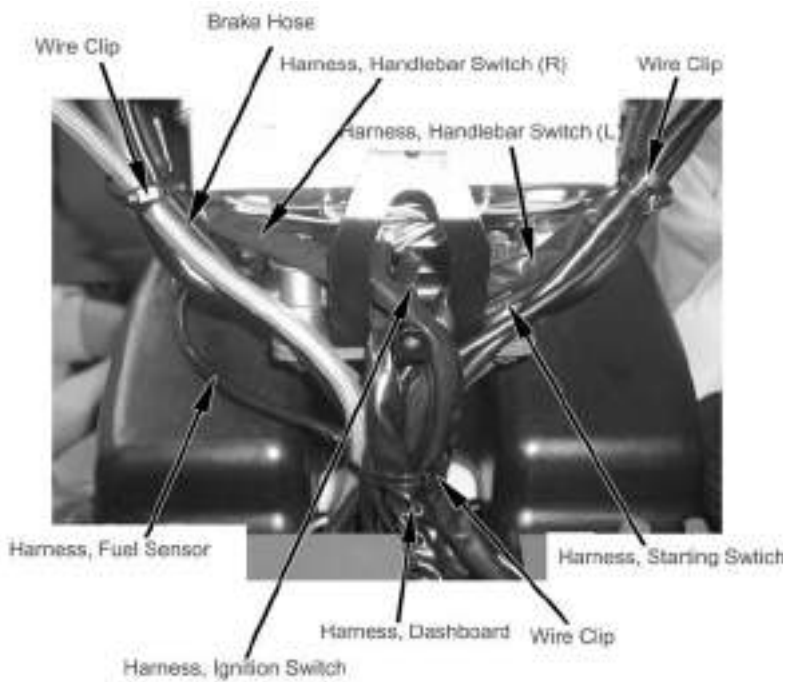
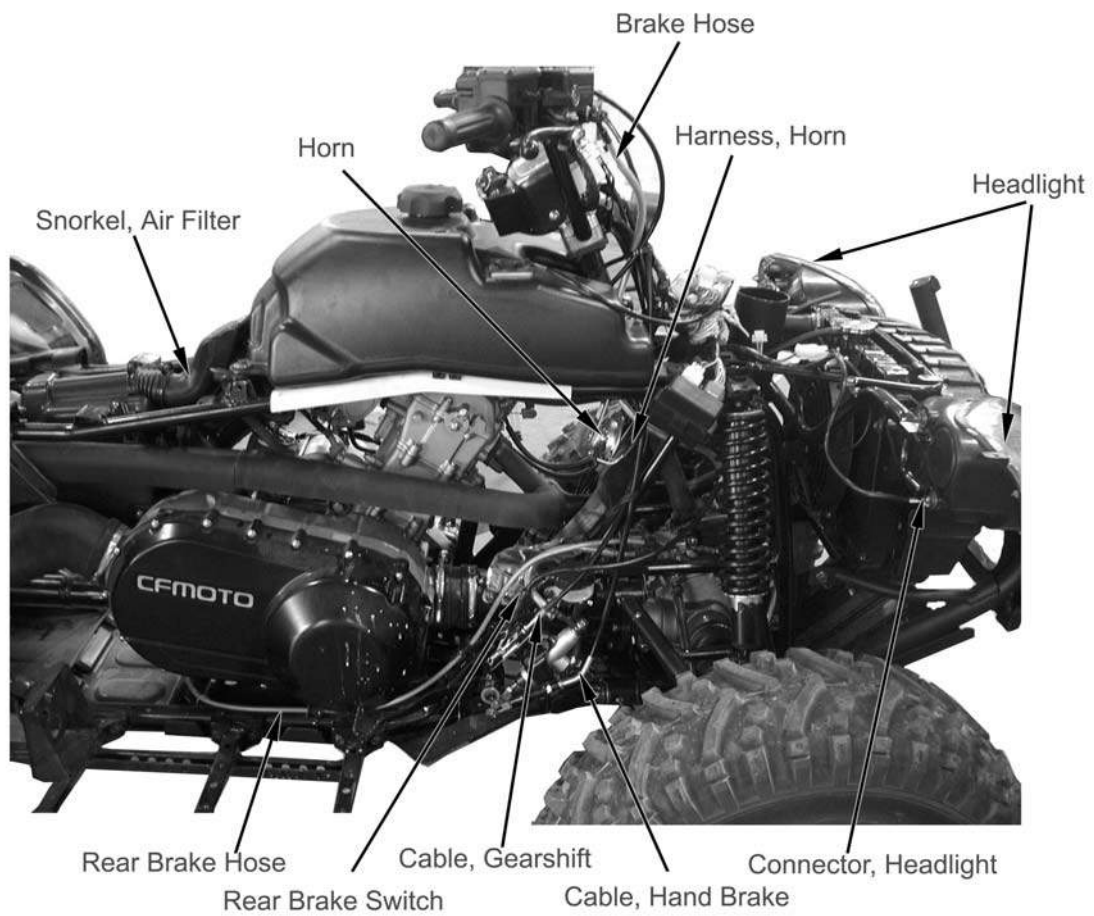

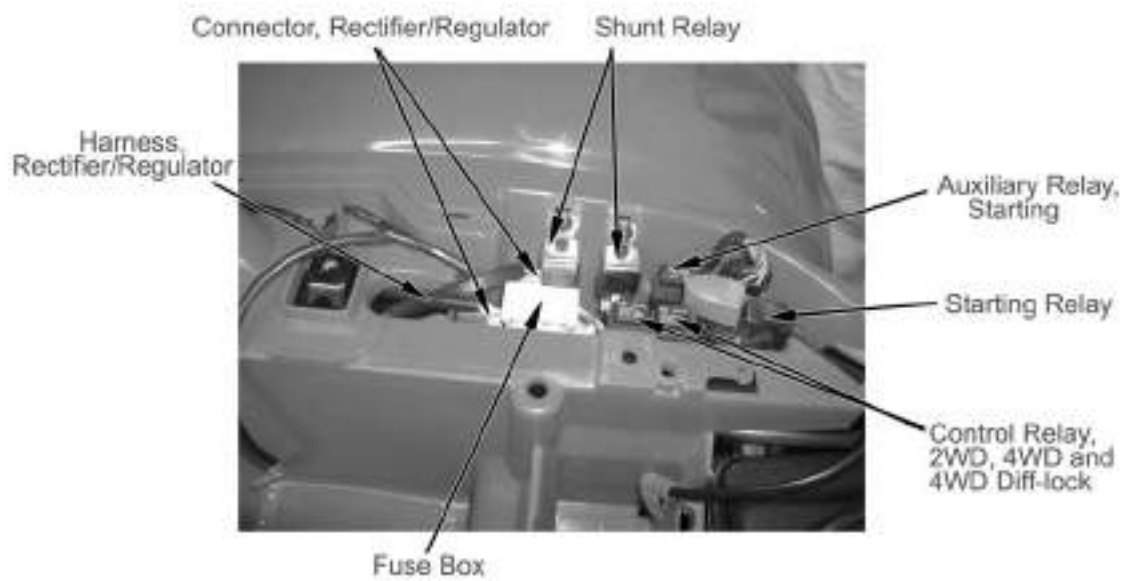
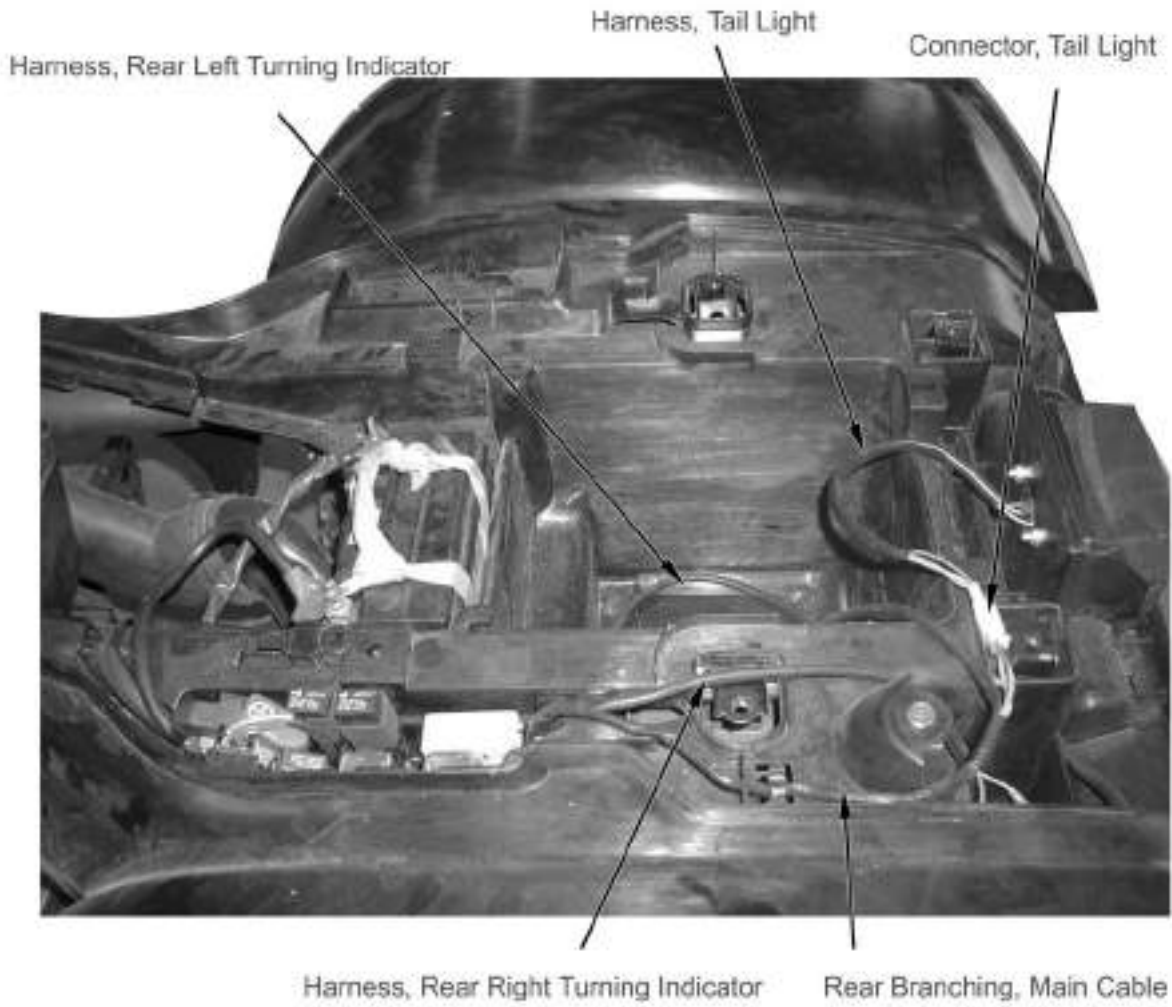

Overhaul Info.....	2-1	Rear Fender, Engine Skid Plate (Front, Center, Rear),	
Troubleshooting.....	2-1	Double Seat, Protection Plate.....	2-10
Front Rack, Bolt Cap.....	2-2	Front Inner Fender (RH,LH), Front Protector (RH, LH)...	2-12
Seat, Seat Support & Rear Rack.....	2-3	Rear Protector (RH,LH), Bumper, Bumper Protector.....	2-13
Front & Rear Rack Panels, Front Top Cover....	2-4	Bumper Cap.....	2-14
Rear Top Cover.....	2-5	Front Vent Grille, Fuel Tank.....	2-15
Left Side Panel.....	2-6	Bottom Plate, Fuel Tank.....	2-16
Right Side Panel.....	2-7	Muffler.....	2-17
Fuel Tank Top Cover, Front Fender.....	2-8	Description of Visible Parts.....	2-18
Footrest Board (LH, RH).....	2-9		

Overhaul Information

Operation Cautions

Warning

Gasoline is highly flammable, therefore smoke and fire are strictly forbidden in the work place. Special attention should also be paid to sparks. Gasoline may also be explosive when it is vaporized, so operation should be done in a well-ventilated place.

Remove and Install muffler after it is fully cold.

- This chapter is on the disassembly and installation of rack, visible parts, exhaust pipe, muffler and fuel tank.
- Hoses, cables and wiring should be routed properly.
- Replace the gasket with a new one after muffler is removed.
- After muffler is installed, check if there is any exhaust leakage.

Tightening torque

Muffler Rear Fixing Bolt: 35-45N.m

Muffler Exhaust Pipe Bolt: 35-45N.m

Muffler Body Fixing Bolt: 35-45N.m

Troubleshooting

Loud exhaust noise

- Broken muffler
- Exhaust leakage

Insufficient power

- Distorted muffler
- Exhaust leakage
- Muffler clogged

Front Rack, Bolt Cap

Remove:

Remove 2 nuts from the bottom of front fender

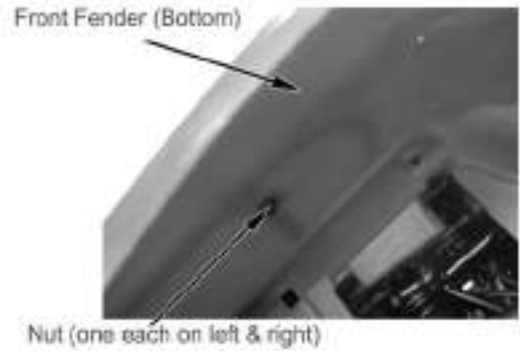

Exert upward and remove bolt cap



Remove:

--Fixing Bolt 1 , Bolt 2

--Fixing Bolt 3, Bolt 4

--Front rack

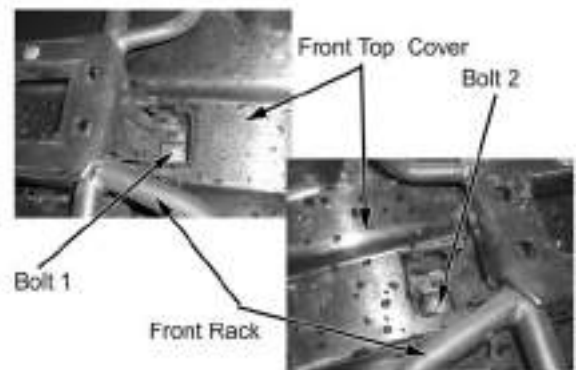

Installation:

Reverse the removal procedure for installation

Tightening Torque: Fixing Bolt 1, Bolt 2
35 N.m -45N.m
Fixing Bolt 3, Bolt 4
25 N.m -30N.m



Seat

Remove:

Pull upward seat buckle
Lift and push seat backward

Installation:

Press upward seat buckle
Press seat forward and down

Note:

Make sure that the seat is firmly installed.



Seat Buckle

Seat Support, Rear Rack

Remove:

--Seat (→2-3)
--Bolt 1, bolt 2
Remove seat support

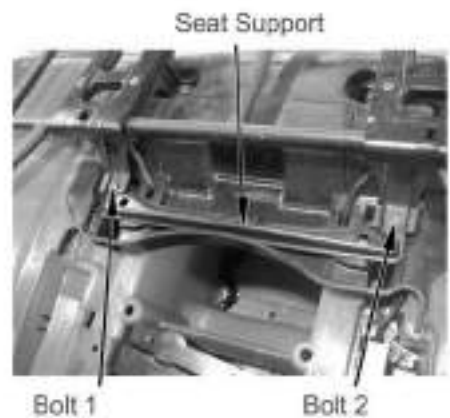

Remove the 2 nuts for rear rack and rear fender from rear fender bottom

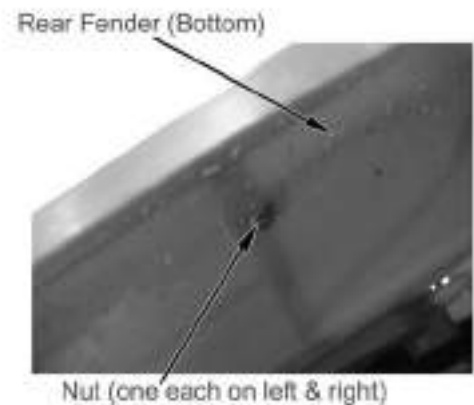

Disconnect connectors of rear turning indicator



Remove Bolt 1, Bolt 2
Remove rear rack

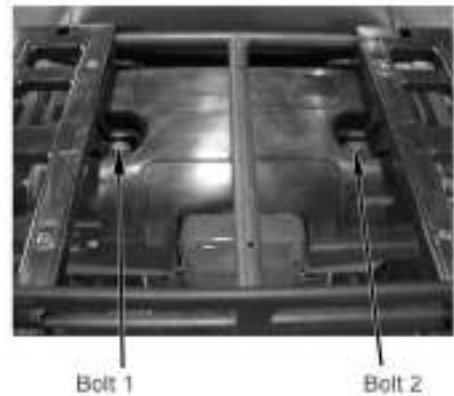

Installation

Reverse the removal procedure for installation

Tightening Torque: Fixing Bolt, Rear Rack
35 N.m -45N.m

Ornament Panel, Front Rack

Remove:

Remove four tapping screw from front rack

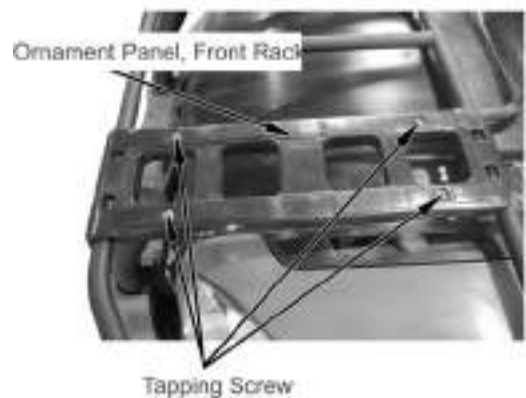

Installation:

Reverse the removal procedure for installation.

Ornament Panel, Rear Rack

Repeat above procedure for removal and installation of ornament panel, rear rack.

Front Top Cover

Remove:

Remove front rack (→2-2)

Push upward plastic screw from front fender bottom with a flat screwdriver;
Remove plastic screw and plastic screw seat

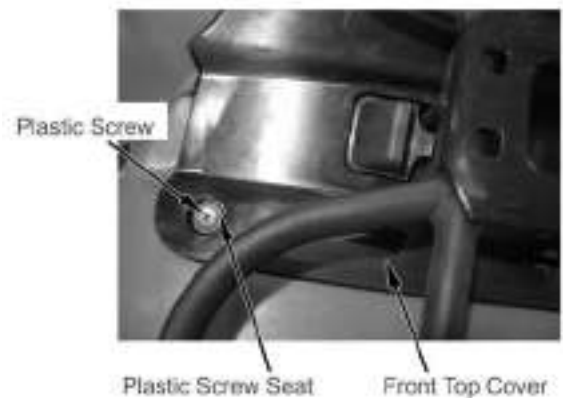

Separate clasps of top cover from fuel tank and front fender as illustrated on the right;
Push forward and remove front top cover.

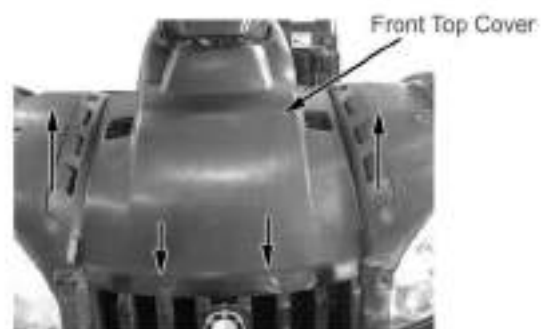

Installation:

Reverse the removal procedure of installation.

Rear Top Cover

Remove:

--Rear rack (→2-3)

Separate clasps of rear top cover from rear fender

Remove rear top cover



Installation:

Reverse the removal procedure and direction for installation.

Left Side Panel

Remove

--Seat (→2-3)

Remove Bolt 1 for left side panel and fuel tank top cover

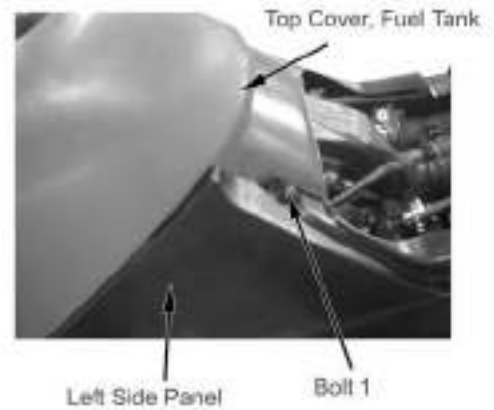

Remove Bolt 2 for left side panel and front fender

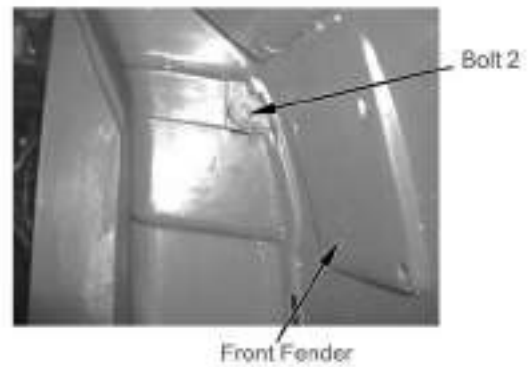

Remove screw for left side panel and footrest board

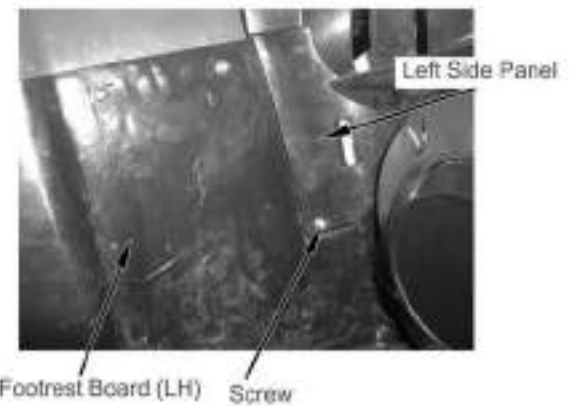

Remove left side panel in the direction as illustrated on the right



Installation:

Reverse the removal procedure of installation.

Right Side Panel

Remove:

--Seat (→2-3)

Remove Bolt 1 for right side panel and fuel tank top cover

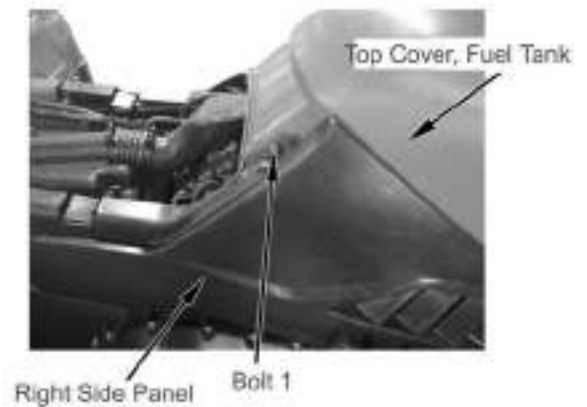

Remove Bolt 2 for right side panel and front fender

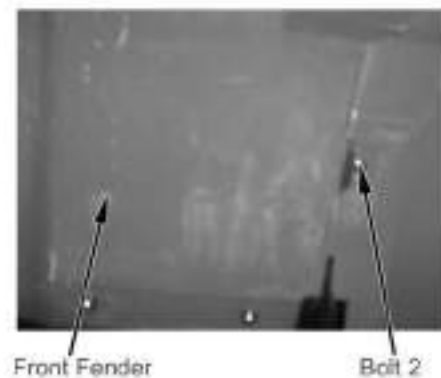

Remove screw for right side panel and right footrest board

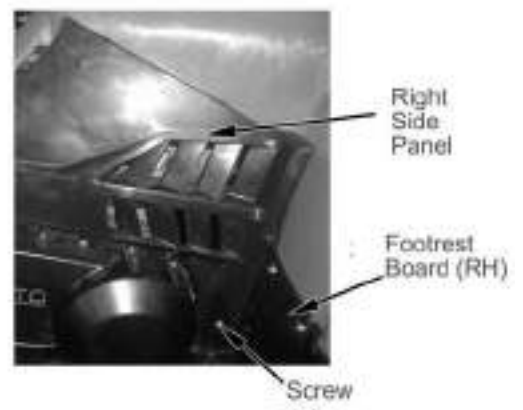

Remove right side panel in the direction as illustrated on the right



Installation:

Reverse the removal procedure of installation.

Top Cover, Fuel Tank

Remove:

- Seat (→2-3)
- Front rack (→2-2)
- Front top cover (→2-4)
- Left side panel (→2-6)
- Right side panel (→2-7)
- Bolt 1, Bolt 2

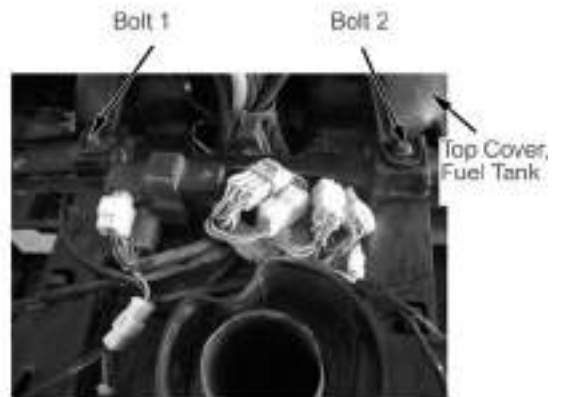

- Bolt 3, Bolt 4
- Top cover, fuel tank

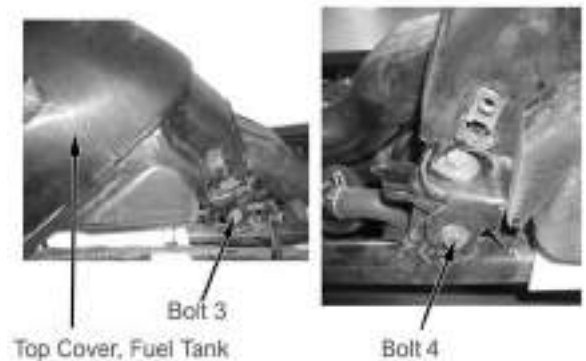

Installation:

Reverse the removal procedure of installation.

Front Fender

Remove:

- Front rack (→2-2)
- Front top cover (→2-4)
- Left side panel (→2-6)
- Right side panel (→2-7)
- Top cover, fuel tank (→2-8)

Disconnect wiring connectors from front fender;
Remove electrical components from front fender;
Remove 3 bolts from frame

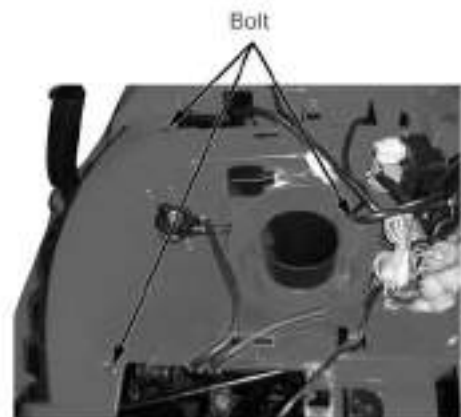

Remove 6 screws and nuts from left and right footrest board

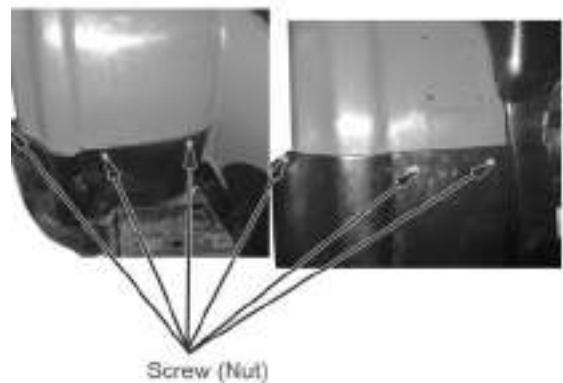

Remove front fender

Left Footrest Board

Remove:

- Left Side panel (→2-6)
- 3 screws & nuts for front fender

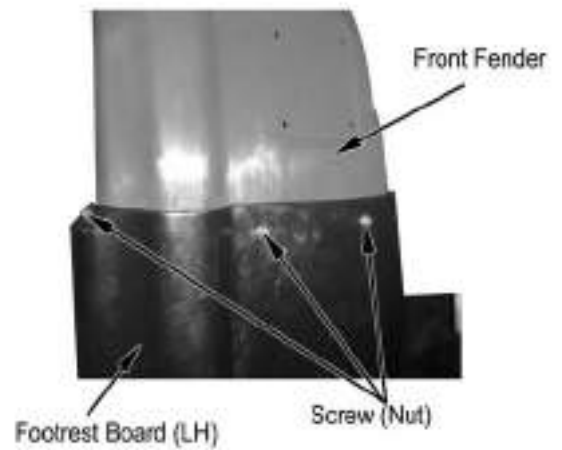

- 3 screws & nuts for rear fender

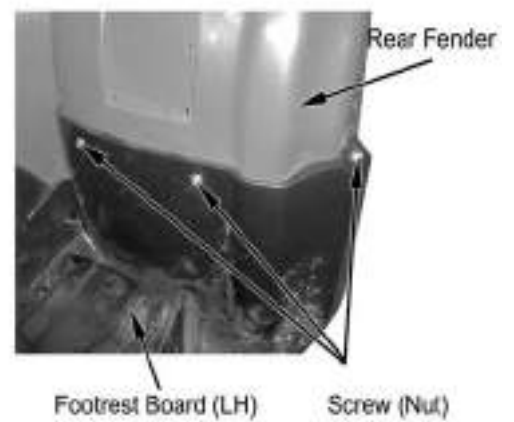

- Bolt 1
- Bolt 2
- Bolt 3
- Bolt 4
- Left footrest board

Installation:

Reverse the removal procedure for installation.

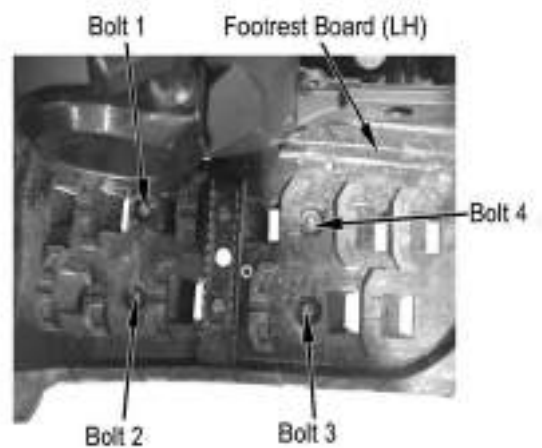

Right Footrest Board

Refer to Left Footrest Board for removal and installation

Rear Fender

Remove:

- Seat (→2-3)
- Rear rack(→2-3)
- Rear top cover (→2-5)
- Left & right side panel (→2-6) (→2-7)
- Battery fixing plate, battery cover (→8-4)

Remove battery

Remove electrical components from rear fender
(Chapter 8)

Disconnect wiring connectors from rear fender
(Chapter 8)

Lift upward and remove rear fender

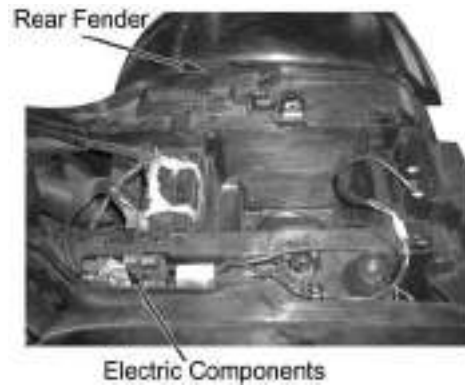

**Engine Skid Plate(Front), Engine Skid Plate (Center),
Double Seat Protection Plate, & Engine Skid Plate
(Rear)**

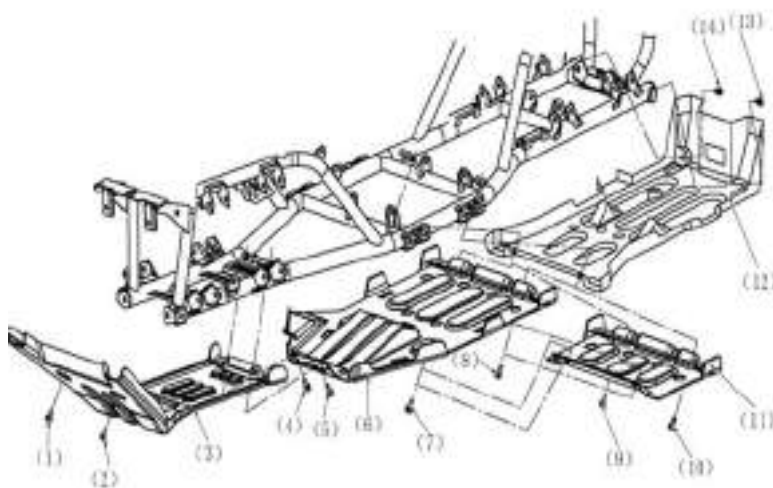

- (1) Bolt 1
- (2) Bolt 2
- (3) Engine Skid Plate(Front)
- (4) Bolt 3
- (5) Bolt 4
- (6) Engine Skid Plate (Center)
- (7) Bolt 5
- (8) Bolt 6
- (9) Bolt 7
- (10) Bolt8
- (11) Double Seat Protection Plate
- (12) Engine Skid Plate (Rear)
- (13, 14) Bolt 9
- (15) Bolt 10

Disassembly

Note: Side skid plate (front), side skid plate (center), side skid plate (rear) and double seat protection plate are located at the bottom of vehicle.

The maintenance person should have to work under the vehicle bottom when disassembling the above parts. For safety purpose, make sure that the vehicle should be firmly parked.

Engine Skid Plate (Front)

Remove:

- Bolt 1
- Bolt 2
- Bolt 3
- Bolt 4
- Engine skid plate (Front)

Installation:

Reverse the removal procedure for installation.

Engine Skid Plate (Center)

Remove:

- Bolt 5
- Bolt 6
- Engine skid plate (center)

Installation:

Reverse the removal procedure of installation.

Double Seat Protection Plate

Remove:

- Bolt 7
- Bolt 8
- Double seat protection plate

Note: This part is not available for single seat vehicle.

Installation:

Reverse the removal procedure of installation.

Engine Skid Plate (Rear)

Remove:

- Bolt 9
- Bolt 10
- Engine skid plate (rear)

Installation:

Reverse the removal procedure for installation.

Front Right Inner Fender

Remove:

- Bolt 1
- Bolt 2
- Front right inner fender

Installation:

Reverse the removal procedure for installation.

Note: The clasp of front right inner fender should hook water pipe when it is assembled.

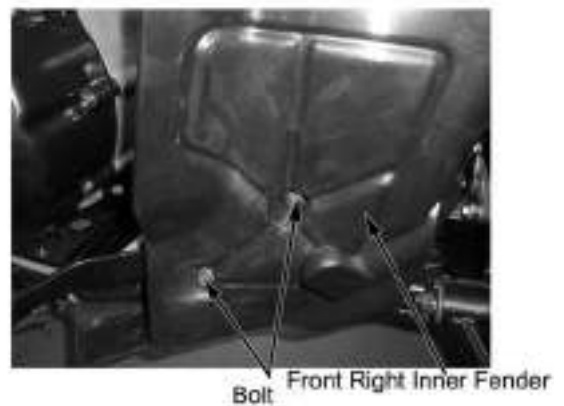

Front Left Inner Fender

Remove:

- Bolt 1
- Bolt 2
- Front left inner fender

Installation:

Reverse the removal procedure for installation.

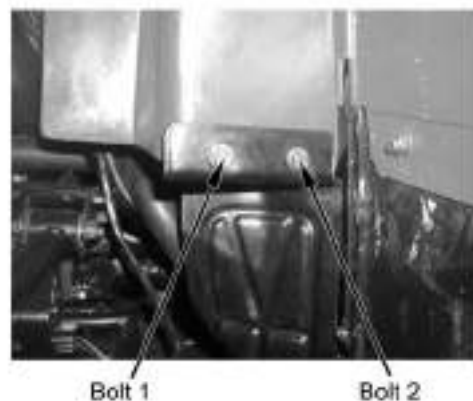

Front Left Protector

Remove:

- Bolt 1
- Pull backward and remove front left protector

Installation:

Reverse the removal procedure for installation.

Front Right Protector

Repeat the above procedure of removal and installation for front right protector.

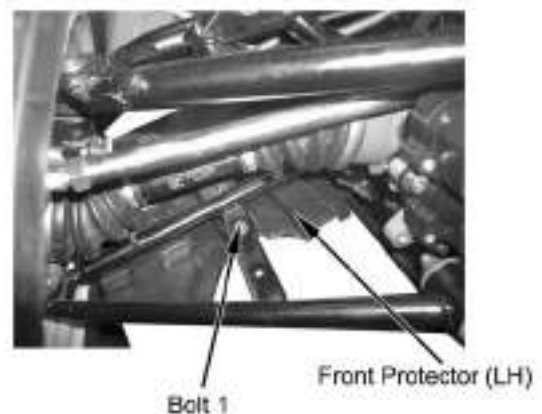

Rear Left Protector

Remove:

- Bolt 1
- Bolt 2
- Rear left protector

Installation:

Reverse the removal procedure for installation.

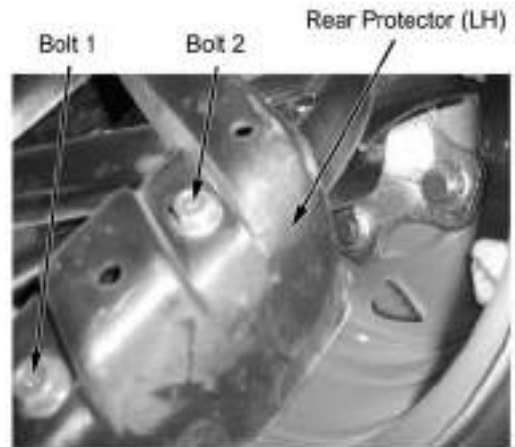

Rear Right Protector

Repeat the above procedure of removal and installation for rear right protector.

Bumper, Bumper Protector,

Remove:

- 2 bolts from engine skid plate (front)

- Bolt 1
- Bolt 2
- Bolt 3
- Bolt 4

Remove bumper with bumper protector

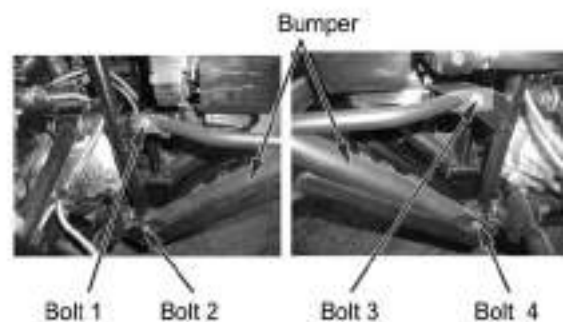
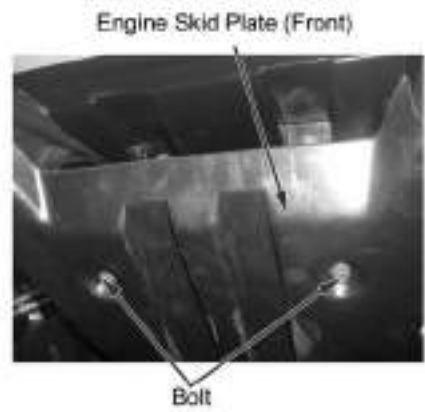

Remove Bolt 5 and Bolt 6 for bumper and front rack



Bumper Protector

Remove:

Remove bumper with bumper protector (→2-13),
Remove tapping screw of protector from bumper

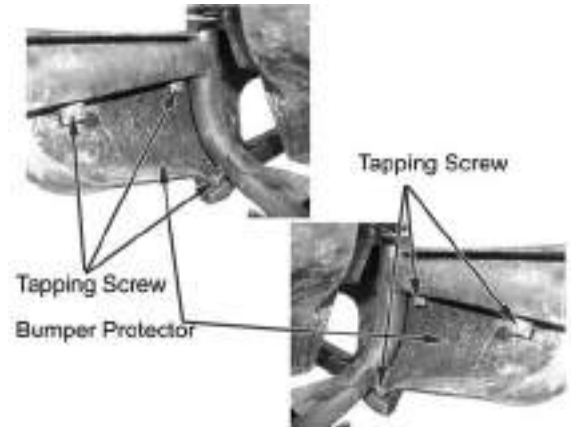

Installation:

Reverse the removal procedure for installation

Bumper Cap

Remove:

There are four pieces of bumper caps, each
at the end of bumper pipe.
Pull bumper cap out from the end of bumper.



Installation:

Press bumper cap into bumper pipe.

Front Vent Grille

Remove:

- Front fender (→2-8)
- Bumper (→2-13)
- Bolt 1, Bolt 2, Bolt 3, Bolt 4
- Front vent grille

Note: For removal of front vent grille only, Just remove 2 fixing bolts of bumper and 2 center fixing bolts, then pull bumper down

Installation:

Reverse the removal procedure for installation

Fuel Tank

Warning: Gasoline is highly flammable, therefore smoke and fire are strictly forbidden in the work place. Special attention should also be paid to sparks. Gasoline may also be explosive when it is vaporized, so operation should be done in a well-ventilated place.

Remove:

- Left and right side panel (→2-6)
- Front fender (→2-8)
- Fuel tank top cover (→2-8)
- Bolt 1, Bolt 2

Disconnect 3P connectors of fuel sensor

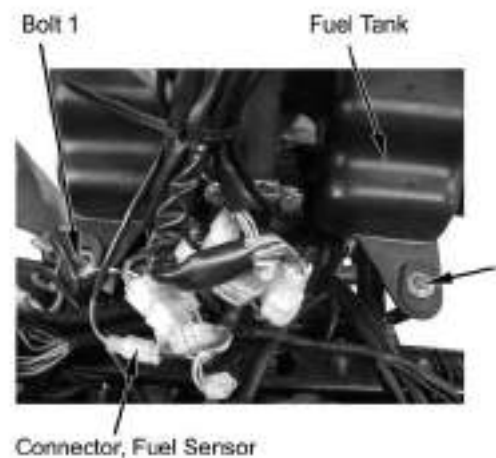
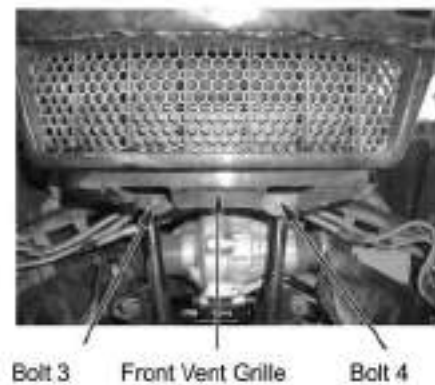
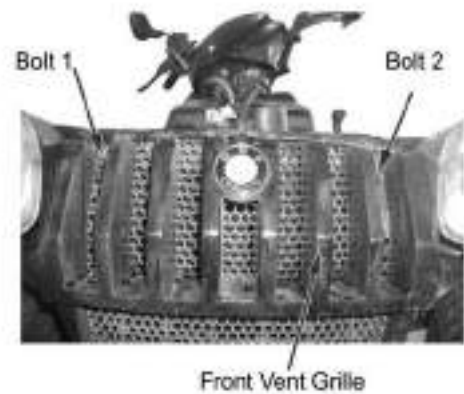

Remove Bolt 3, Bolt 4

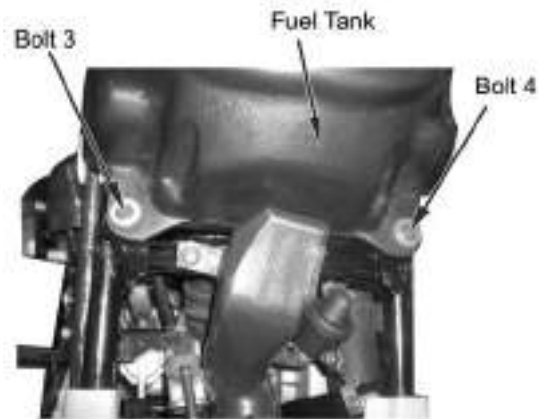

Remove:

- Fuel hose I and Clamp
- Fuel tank

Installation:

Reverse the removal procedure for installation.

Note:

Be careful not to damage main cable, pipes and hoses. Main cable, cables, pipes and hoses should be routed properly according to the routing drawing. Take precaution against fuel leakage when removing fuel Fuel Hose I

Fuel Hose I (Clamp)



Fuel Tank Bottom Plate,

Remove:

- Fuel tank (→2-15)
- Bolt 1
- Bolt 2
- Fuel tank top cover

Installation:

Reverse the removal procedure for installation.

Note:

Be careful not to damage main cable, pipes and hoses. Main cable, cables, pipes should be routed properly according to the routing drawing



Bottom Plate, Fuel Tank Bolt

Muffler

Caution: Perform disassembly only after the muffler is cooled down.

Remove:

- Seat (2-3)
- Right side panel (2-7)
- Nut1, Nut 2 for exhaust pipe elbow

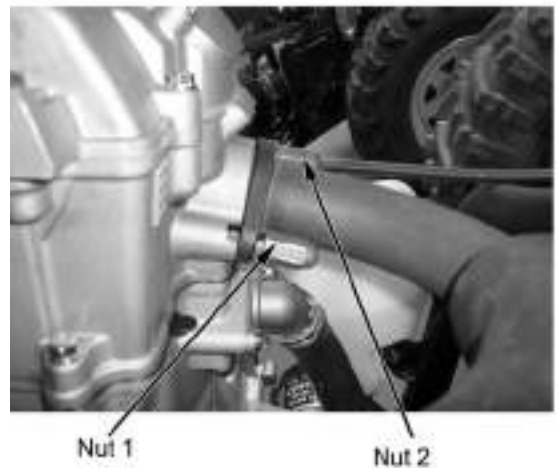

Remove Bolt 1

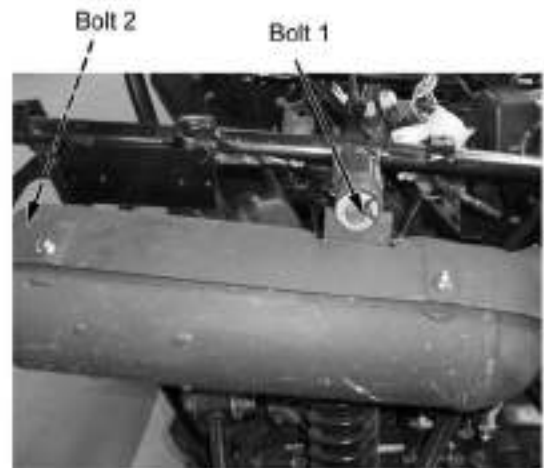

Remove Bolt 2, Bolt 3
Remove muffler

Installation:

Reverse the removal procedure for installation.

Note:

Replace sealing gasket when installing the muffler.

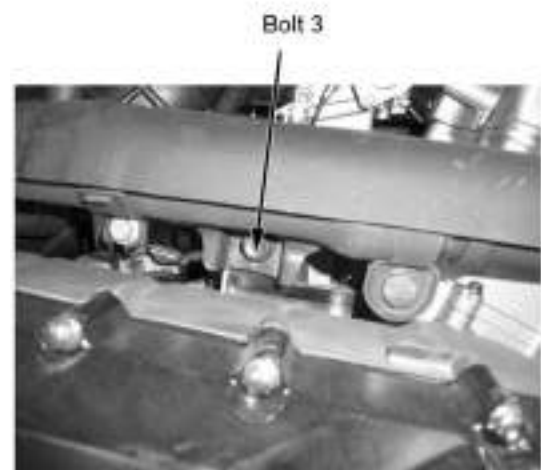

Visible Parts

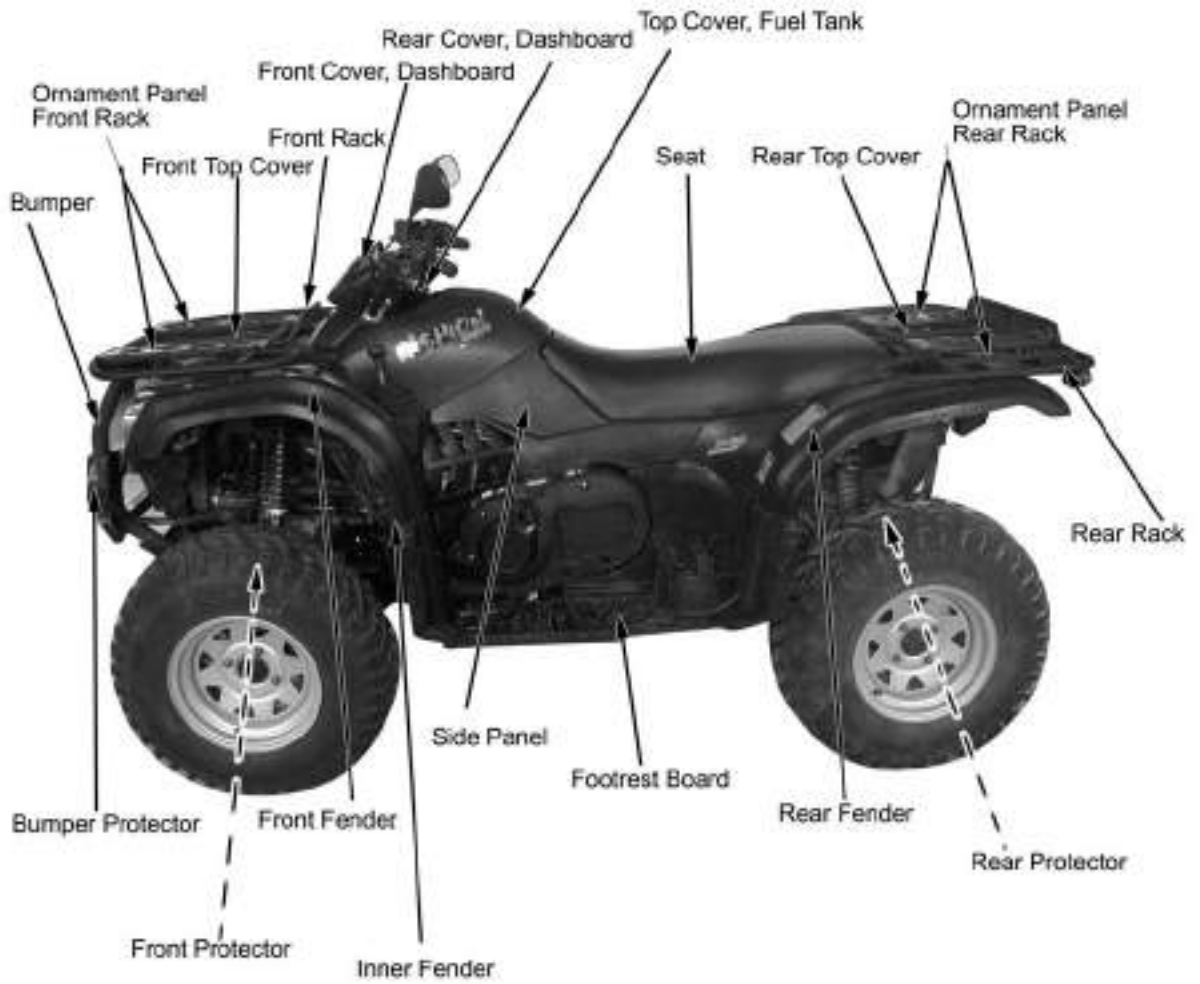

Overhaul Info.....	3-1	Suspension System.....	3-9
Inspection & Maintenance.....	3-2	Gear Shifting, Fuel Device.....	3-10
Steering Stem, Brake System.....	3-5	Cooling System.....	3-12
Wheels.....	3-7	Lighting System.....	3-14

Overhaul info**Operation Cautions****Note**

- DO NOT keep the engine running for long time in a poorly ventilated or enclosed place because of the harmful components like CO, etc, in the exhaust gas.
- The muffler and engine are still very hot when the engine is just stopped. Careless contact may cause serious burn. Be sure to wear fatigue dress with long sleeves and gloves if the work has to be done after the engine is just stopped.
- Gasoline is highly flammable, smoking is strictly forbidden in the work place. Keep alert on the electrical sparks. Besides, vaporized gasoline is highly explosive, so work should be done in a well-ventilated place.
- Be careful that your hands or clothes not get nipped by the turning or movable parts of the driving system.

Note

The vehicle should be parked on hard and level ground.

Periodic Maintenance Table

The table below lists the recommended intervals for all the required periodic maintenance work necessary to keep the vehicle at its best performance and economy. Maintenance intervals are expressed in terms of kilometer, miles and hours, whichever occurs first.

Note: More frequent maintenance may be required on vehicles that are used in severe conditions.

Interval Item	Km	Initial 200	Every 1000	Every 2000	Remark
	Miles	Initial 100	Every 600	Every 1200	
	Hours	Initial 20	Every 40	Every 80	
Valve Clearance		I	--	I	IN: 0.05~0.10 EX:0.17~0.22
Idle Speed		I	I	I	1300±100r/Min
Spark Plug		--	--	I	No carbon deposit
	Replace every 6000Km				Gap: 0.8~0.9mm
Air Filter		--	C	C	Replace every 2000Km
Fuel Hose, Carburetor		--	--	I	Replace every 4 years
Clutch		--	--	I	
Drive Belt		--	I	R	
Oil Filter		R	--	R	
Coolant Level		I	I	I	
Water Hose & Pipes		I	I	I	
Coolant	Replace every 2 years				

I=Inspection and adjust, or replace if necessary

R=Replace

C=Clean

Inspection & Maintenance

○: Interval

Item		Intervals			Standard	
Part	Item	Daily	1/2 Year	Annual		
Steering System	Handlebar	Operation agility	○			
	Steering system	Damage	○			
		Installation condition of steering system	○			
		Sway of ball stud	○			
Brake System	Brake lever	Free play	○	○	○	Front: lever end 0mm Rear : lever end 0mm
		Brake Efficiency	○	○	○	
	Connecting rod, oil pipe & Hose	Looseness, Slack and damage	○		○	
	Hydraulic brake and brake disc	Front and rear brake fluid level	○	○	○	Brake fluid should be above LOWER limit
		Brake disc damage and wear	○	○	○	Replace when the thickness of front brake disc is less than 2.5mm, rear brake less than 6.5mm.
Driving System	Wheel	Tire pressure	○	○	○	Front tire: 35kPa (0.350kgf/cm ²) Rear tire: 35kPa (0.35kgf/cm ²)
		Chap and damage	○		○	
		Groove depth and abnormal wear	○		○	No wear indication on the surface of tire (the remained depth of groove should not be less than 1.6mm)
		Loosened wheel nut and axle	○	○	○	
		Sway of front wheel bearing	○		○	
		Sway of rear wheel bearing	○		○	

Buffer System	Suspension arm	Sway of Joint parts, rocker arm damage	○		○	
	Shock absorber	Oil leakage and damage	○		○	
		Function			○	
Drive Train	Front axle	Transmission, lubrication	○		○	
	Rear axle	Transmission, lubrication	○		○	
	Gear box	Transmission, lubrication	○		○	Remove filling bolt, add oil till oil level reaches edge of filling hole.
	Final shaft (Drive shaft)	Looseness of joint parts	○	○	○	
		Sway of Spline			○	
Electrical System	Ignition Device	Spark plug		○	○	Spark plug gap: 0.8-0.9mm
		Ignition timing		○	○	
	Battery	Terminal Joint			○	
	Wiring	Looseness and damage of joints			○	
Engine	Fuel device	Fuel leakage		○	○	
		Throttle			○	Throttle grip clearance: 3~5mm
	Cooling system	Coolant level	○	○	○	
		Coolant leakage			○	

Lighting device and turning indicators	Function	<input type="radio"/>	<input type="radio"/>	<input type="radio"/>	
Alarm and lock device	Function			<input type="radio"/>	
Instruments	Function			<input type="radio"/>	
Exhaust pipe and muffler	Looseness or damage caused by improper installation			<input type="radio"/>	
	Function of muffler			<input type="radio"/>	
Frame	Looseness and/or damage			<input type="radio"/>	
Others	Lubrication & grease of frame parts			<input type="radio"/>	
Abnormal parts which can be determined when driving	Make sure if there is any abnormal with relative parts.	<input type="radio"/>			

Steering Stem

Park the vehicle on level place, hold steering handlebar, and shake in the direction as illustrated on the right and see if there is any sway.

In case of any sway, check if it is the problem of the steering stem or other parts and then do the maintenance accordingly.

In case of sway of the steering stem, tighten the locknut or disassemble the steering stem for further check.

Park the vehicle on level place, slowly turn the handlebar left and right to see if it can turn freely.

In case there is any hindrance, check if it is from the main cable assembly or other cables.

If no, check the steering tie-rod end, and check if the steering stem bearing is damaged.

Note:

**Make sure the steering can be operated freely.
An accident may occur
if the handlebar is out of control.**

Brake system

Front brake lever free play

Operate front brake lever and check brake efficiency and brake lever function.

Check free play of front lever end.

Free play: 0mm



Master Cylinder

<Fluid level>

Check the brake fluid level

When the brake fluid level is near to the lower limit line, check master cylinder, brake hoses and joints for leakage. Remove the two mounting screws on fluid reservoir cap.

Remove the cap, add DOT3 or DOT4 brake liquid till the upper limit line.

- Do not mix with dust or water when adding brake fluid.
- Use only the recommended of brake fluid to avoid chemical reaction.
- Brake fluid may cause damages to the surface of the plastic and rubber parts. Keep the fluid away from these parts.
- Slightly turn the handlebar left and right till the master cylinder is in horizontal, then remove the fluid reservoir cap.



Brake Disc, Brake Pad

< Wear of brake pad>

Check the brake pad wears from the mark as indicated.

Replace the brake pad if the wear has reached position of wear limit trough.

Note

The brake pad must be replaced with a whole set.

Checking and replacing the brake disc

Front brake disc thickness: ≤ 2.5 mm → Replace

Rear brake disc: ≤ 6.5 mm → Replace

Min. limited thickness of the front brake disc: 2.5mm

Min. limited thickness of the rear brake disc: 6.5mm

Change the Brake Fluid

< Changing Brake Fluid>

Change the brake fluid once every year.



Wheels

Lift front wheel on level place, and make sure there is no loading on the wheels.

Shake the front wheel left and right to check whether the joint of front wheel is tightened and check whether it sways.

Not tighten enough: →Tighten it
Sway: →Replace the rocker arm

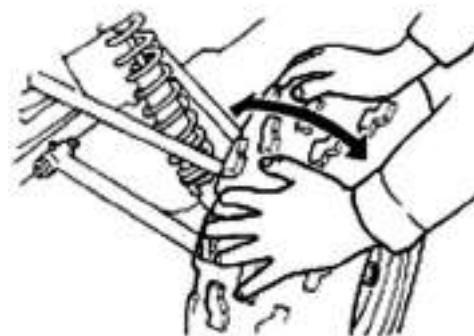

Front Toe-in size

Park the vehicle on level place, measure the front toe-in

Toe-in: $B-A=0-10\text{mm}$

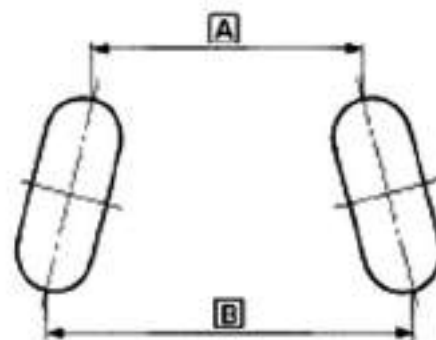

Toe-in out of the range: → Adjust the locknut of tie-rod

Note:

After the toe-in has been adjusted, slowly run the vehicle to check whether the direction of vehicle can be controlled by handlebar.

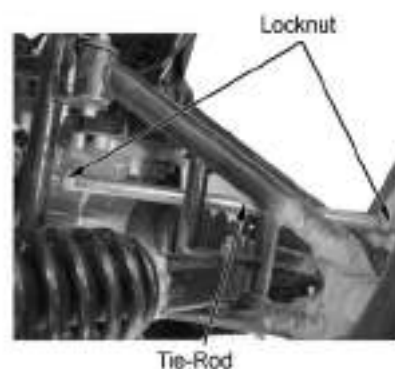

Tire Pressure

Check the pressure of the tires with a pressure gauge.

Note

Check the tire pressure after tires are cooled.

Driving under improper tire pressure will reduce the comfort of operation and riding, and may cause deflected wear of the tires.

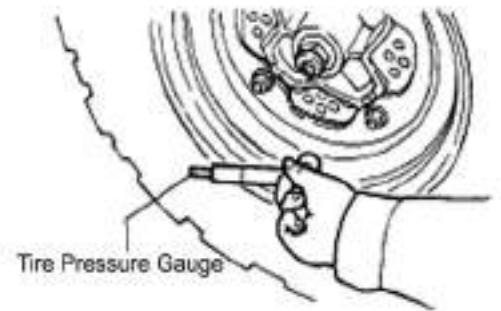

Specified pressure /tire

	Front wheel	Rear wheel
Pressure	35kPa(.035k gf/cm ²)	35kPa(0.50k gf/cm ²)
Tire Size	25x8-12	25x10-12

Tire Tread

Check the tire tread.

Tread Height: < 3mm→Replace with new tires

Note:

When the tread height is less than 3mm, the tire should be replaced immediately.

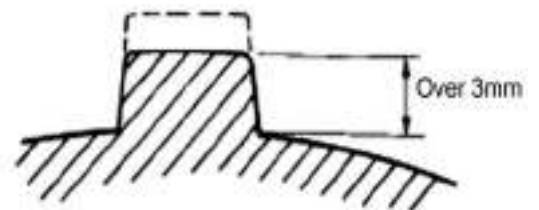

Wheel Nut and Wheel Axle

Check front and rear wheel axle nuts for looseness

Loosened axle nuts: →Tighten

Tightening Torque:

Front wheel axle nut:

110-130N • m(11.2kgf • m-13.3kgf • m)

Rear wheel axle nut:

110-130N • m(11.2kgf • m-13.3kgf • m)



Nut, Wheel Axle

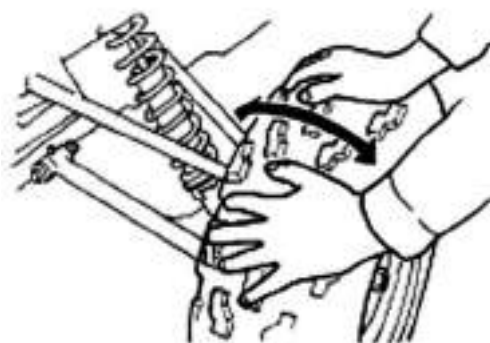

Sway of Wheel Bearing

Lift the front wheel

Make sure there is loading on the vehicle

Shake the wheel in axial direction for any sway

In case of any sway,

disassemble the front wheel and check the bearing

Suspension System

Park the vehicle on level place, press the vehicle several times up and down as illustrated on the right.

In case of any rocking or abnormal noise, check whether there is any oil leakage from absorbers, or any damage or looseness of tightening parts.



Adjusting the Absorber

Use special tools to adjust the length of absorber according to loading requirement

Turn clockwise to adjust from high to low

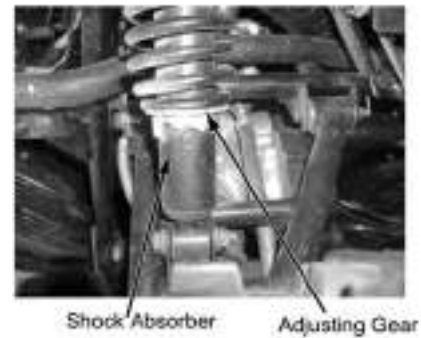

Gear Shifting

Shift the gear to check for flexibility and gear engagement

Adjust the gearshift rod if necessary

Release the locknut to adjust the length of gearshift rod



Fuel Device

Status of the fuel system

Remove the seat (→2-3)

Check the fuel hose for any aging or damage.

Aged or damaged fuel hose: → Replace

Check if there is cracks or bending with the vacuum tube.

Cracked or bended vacuum tube: → Replace



Checking the Throttle Lever



Check the free play of throttle lever

Free play: 3-5mm

Out of range: →Adjust

Loosen locknut of throttle cable
turn the regulator and adjust free play of throttle lever

After adjusting, tighten locknuts and install throttle cable sleeve

Replace with a new throttle cable if the specified free play could not be acquired by adjusting the regulator or if there is still stickiness with the throttle.

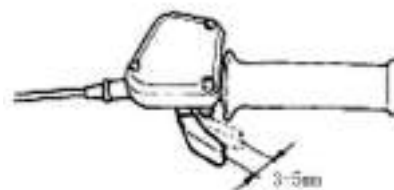

Adjusting the Speed Limiter

The speed limiter is to limit the opening of throttle
Check the maximum length of limiter screw thread

Maximum screw thread: $a=12\text{mm}$

Adjust with a cross driver.



Note:

For beginners, the speed limit should be fully tightened.

Drivers with certain skills may adjust the throttle with speed limiter

Maximum length of screw thread is 12mm.

It is recommended to adjust the thread length to 3-5mm.

Cooling System

Note

- Check coolant level from reservoir tank.
Do not check from radiator.

If the radiator cap is opened while the engine is hot (over 100 °C), the pressure of the cooling system will drop down and the coolant will get boiled rapidly.

DO NOT open the radiator cap until the coolant temperature drops down.

- Coolant is poisonous, DO NOT drink or splash it to skin, eyes, and clothes.
 - In case the coolant gets to the skin and clothes, wash with soap immediately.
 - In case the coolant gets into eyes, rinse with plenty of water and go to consult the doctor
 - In case of swallowing the coolant, induce vomit and consult the doctor.
- Keep the coolant in a safe place and away from reach of children.

Coolant level

Coolant might reduce due to natural evaporation.
Check the coolant level regularly.

Note

- Coolant can prevent rust and resist freeze. Ordinary water may cause engine rust or cracks in winter due to freezing.
- Park the vehicle on level ground for checking of the coolant. Inclined vehicle body will cause incorrect judging of the coolant level.
- Check the coolant after the engine is warmed up.
Start and warm up engine.

Stop the engine.

Remove left side panel (→2-6)

Check if the coolant level is between the upper and lower limit.

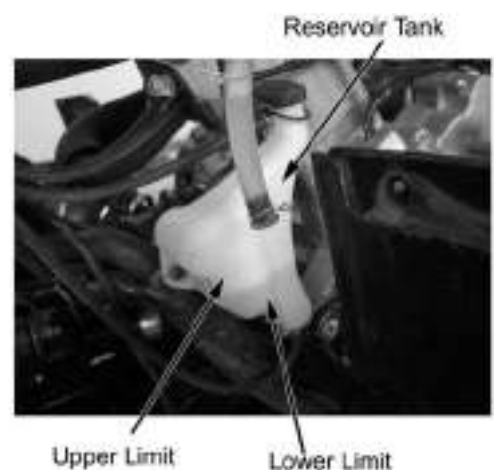

When the coolant level is below the LOWER limit, remove reservoir tank cap and add coolant till upper limit. (Add coolant or diluted original liquid).

Recommended coolant: CFMOTO coolant

Standard density: 50%

(Freezing temperature of coolant varies according to the different mixture ratio. Adjust the mixture ratio according to the lowest temperature in the place where the vehicle is used.)

If the coolant reduces very fast, check if there is any leakage. The cooling system may be mixed with air when there is no coolant in the reservoir tank and the air should be discharged before adding coolant.



Coolant Leakage

Check radiator hose, water pump, water pipes and joints for leakage.

In case of any leakage, disassemble and do further check.

(Refer to Chapter 4)

Check the radiator hose for aging, damages or cracks.

The rubber hose will naturally get aged after a period of service time. The aged hose may get cracked when the cooling system is heated. Nip the hose with fingers and check if there are any tiny cracks.

In case of any abnormal, replace with a new hose.

Check the clamps of the coolant pipes and hose.

Tighten properly in case of any looseness.

Check radiator fins for mud and dust clog or damage.

Correct the bent fins; clean the mud with water and compressed air. When the damaged area of the radiator fin is over 20%, replace with a new radiator.

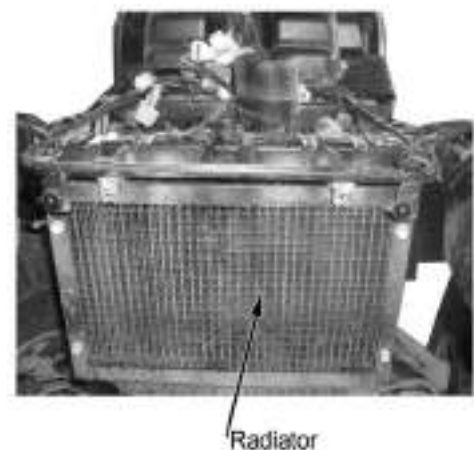

Check Water Temperature Gauge

When engine is not working, the water temperature should be in the "0" position. Start the engine to check if the indicator works. If the indicator is not working, do the maintenance in time.



Water Temperature Gauge Dashboard

Lighting System

Adjusting headlight light beam

Turn the headlight beam adjusting screw with a cross screwdriver and adjust the high/low beam to meet the requirement.



Adjusting Screw, Headlight Beam

Overhauling Info.....	4-1	Adding Coolant.....	4-7
Trouble Shooting.....	4-2	Cooling System Chart.....	4-10
Check and Maintenance.....	4-3		
Reservoir Tank.....	4-5		

Overhaul Information

Note

- If the radiator cap is opened when the coolant temperature is above 100°C, the pressure of coolant will drop and get boiled rapidly. The steam jet may cause danger and injury. Cover the cap with a piece of rag after the coolant temperature goes down and open the cap slowly.
- Inspection of coolant should be done after the coolant is fully cooled.
- Coolant is toxic. Do not drink or splash it to skin, eyes or cloth.
 - If coolant splashes in your eyes, thoroughly wash your eyes with water and consult a doctor.
 - If coolant splashes on your clothes, quickly wash it away with water and then with soap and water.
 - If coolant is swallowed, induce vomit immediately and see a physician.
 - Store the coolant properly and keep it away from reach of children.
- Check radiator fins for mud block and/or damage. Correct the bent fins. Clean off the mud with water and compressed air. Replace with a new one if the damaged fin area reached 20%.
- The overhauling of the water pump can be done without removing the engine.
- Add coolant through reservoir tank. Do not open the radiator cap except when disassembling the cooling system for adding or drainage of coolant.
- Do not stain the plastic parts with coolant. In case of any coolant stains, flush with water immediately.
- After disassembly of the cooling system, check the joints for leakage with a radiator cap tester (available in the market).
- Refer to Chapter 10 for overhauling of temperature transducer.

Inspection standard

	Item	Standard
Coolant Capacity	Full capacity	1140ml
	Reservoir tank capacity	340ml
	Standard density	30%
Opening pressure of radiator cap		108kpa(1.1kgf/cm ²)
Thermostat	Valve open temperature	72±2°C
	Full open Temperature	88°C
	Full open lift	3.5-4.5mm

Tightening torque

Drainage bolt, water pump:	8N · m(0.8kgf · m)
Thermoswitch	10N · m(1.0kgf · m)

Trouble Shooting

Sharp rise of water temperature

- Faulty radiator cap
- Air in cooling system
- Faulty water pump
- Faulty thermostat (thermostat is not open)
- Clogged radiator pipe or cooling pipes
- Damage or clogged radiator fin
- Coolant is not enough
- Faulty or malfunction of fan motor

No rise or slow rise of water temperature.

Faulty thermostat (thermostat is not closed)
Faulty circuit of water temperature display

Coolant leakage

- Faulty water seal
- O-rings are aged, damaged or improperly sealed.
- Washers are aged, damaged or improperly sealed.
- Improper installation of pipes or hoses
- Pipes and/or hoses are aged, damaged or improperly sealed

Check and Maintenance

Checking coolant density

Note:
Open the radiator cap after coolant is fully cooled.

- Remove:
- Front top cover (→2-4)
 - Radiator cap (counter clockwise).

Check with a densimeter if the coolant density adapts to the local temperature.

Check coolant for stains or impurities.

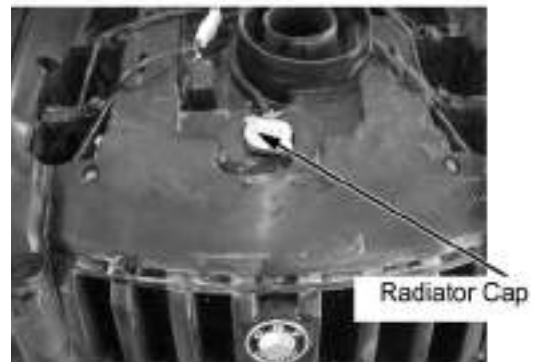

Inspection of radiator cap

Note
Open the radiator cap after the coolant is fully cooled.

- Remove:
- Front top cover (→2-4)
 - Radiator cap (→4-3).

Note
Apply coolant on the sealing surface of radiator cap before attaching the tester to the radiator cap.

Install the radiator cap tester to the radiator cap;

Apply the specified pressure (radiator cap opening pressure) for 6 seconds and make sure that there is drop in pressure.

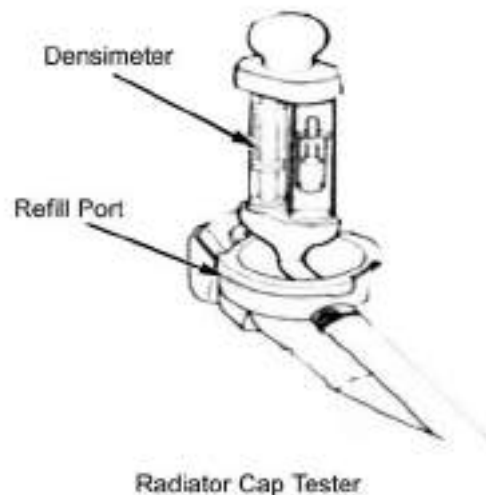

Opening pressure of radiator cap:

108kpa(1.1kgf/cm²)

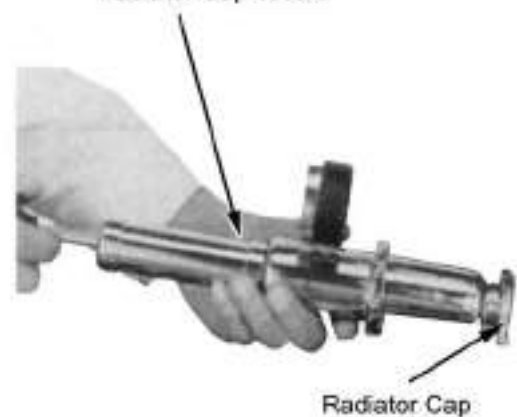

Pressure testing of cooling system

Install the radiator cap tester to the radiator cap;

Apply the specified pressure (radiator cap opening pressure) for 6 seconds and make sure that there is drop in pressure.

Note

Do not apply pressure over the specified pressure [108kpa(1.1kgf/cm²)], or the cooling system may be damaged.

In case there is any pressure leakage, check the pipe, joint parts, joints of water pump and drainage (→4-5).

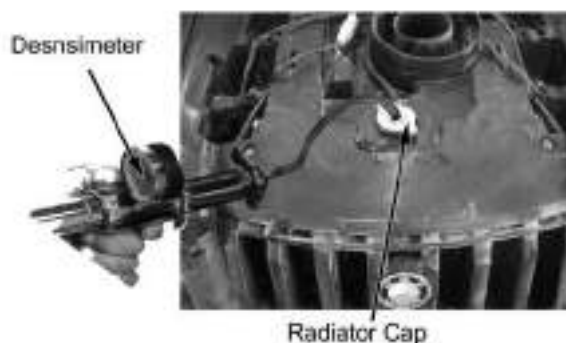

Replacing Coolant, Air Discharge

Preparation of coolant

Coolant is toxic, DO NOT drink or splash it to skin, eyes, and clothes.

- If coolant splashes in your eyes, thoroughly wash your eyes with water and consult a doctor.
- If coolant splashes on your clothes, quickly wash it away with water and then with soap and water.
- If coolant is swallowed, induce vomit immediately and see a physician.
- Store the coolant properly and keep it away from reach of children.

Note

Mix the coolant (undiluted) with soft water according to the temperature 5°C lower than the actual lowest local temperature.

Coolant should be made from undiluted coolant with soft water.

Standard density of coolant: 30%

Recommended coolant: CFMOTO coolant
(Direct application without having to be diluted)

Drainage of coolant

Remove radiator cap cover

Note

Open the radiator cap after the coolant is fully cooled.

Remove:

- Front top cover(→2-8)
- Radiator cap. (→4-3)

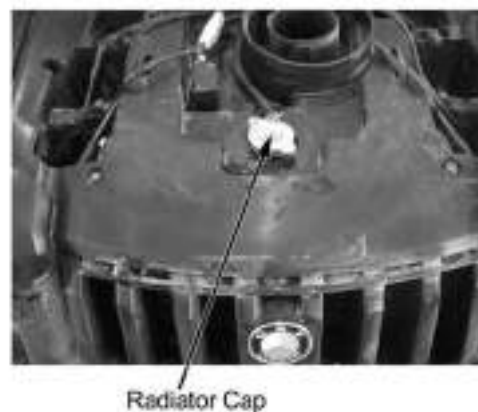
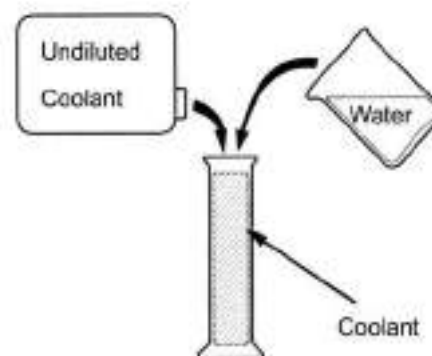

Remove drain bolt

Remove drain bolt, seal gasket from water pump, and drain coolant.
After drainage, assemble with a new seal gasket, drain bolt and tighten.

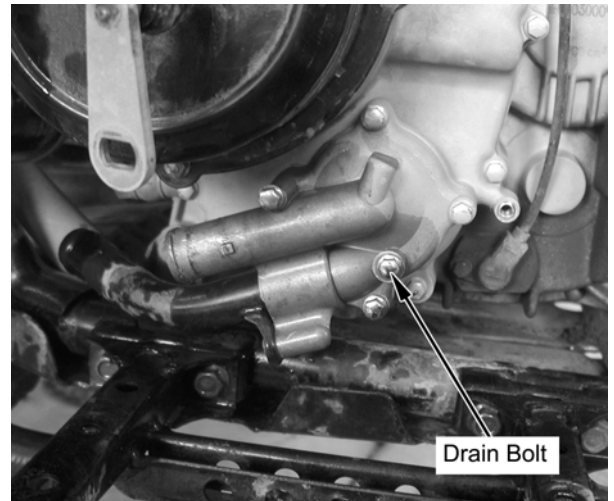

Reservoir Tank

Remove:

- Seat (→2-3)
- Left side panel (→2-6)
- 2 Mounting bolts
- Water hose of reservoir tank

Remove reservoir tank; discharge coolant;
Flush reservoir tank.
Install reservoir tank;
Install water pipe.

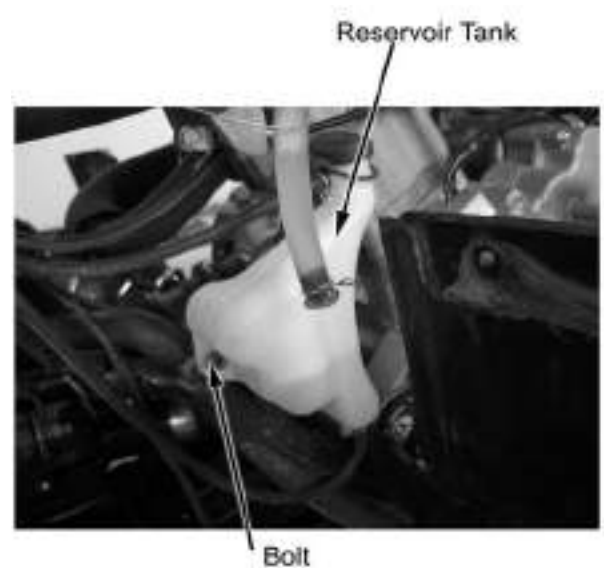

Adding Coolant

Add coolant through filling port.

Start the engine and discharge air from cooling system. Check from filling port that air is fully discharged from cooling system and install the radiator cap.

Remove reservoir tank cap and add coolant till the upper limit.

Note:

Check coolant level when the vehicle is on an even ground.



Refill Port

Air Discharge

Discharge the air from cooling system according to the following steps:

1. Remove drain bolt (→4-5), discharge air and install it.
2. Start the engine and run it several minutes at idle speed;
3. Quickly increase throttle 3~4 times to discharge air from cooling system;
4. Add coolant till filling port;
5. Repeat step 2 & 3 till no more coolant can be refilled;
6. Check coolant level in reservoir tank and refill till upper limit.
7. Install reservoir tank cap.



Lower Limit

Cooling System Chart

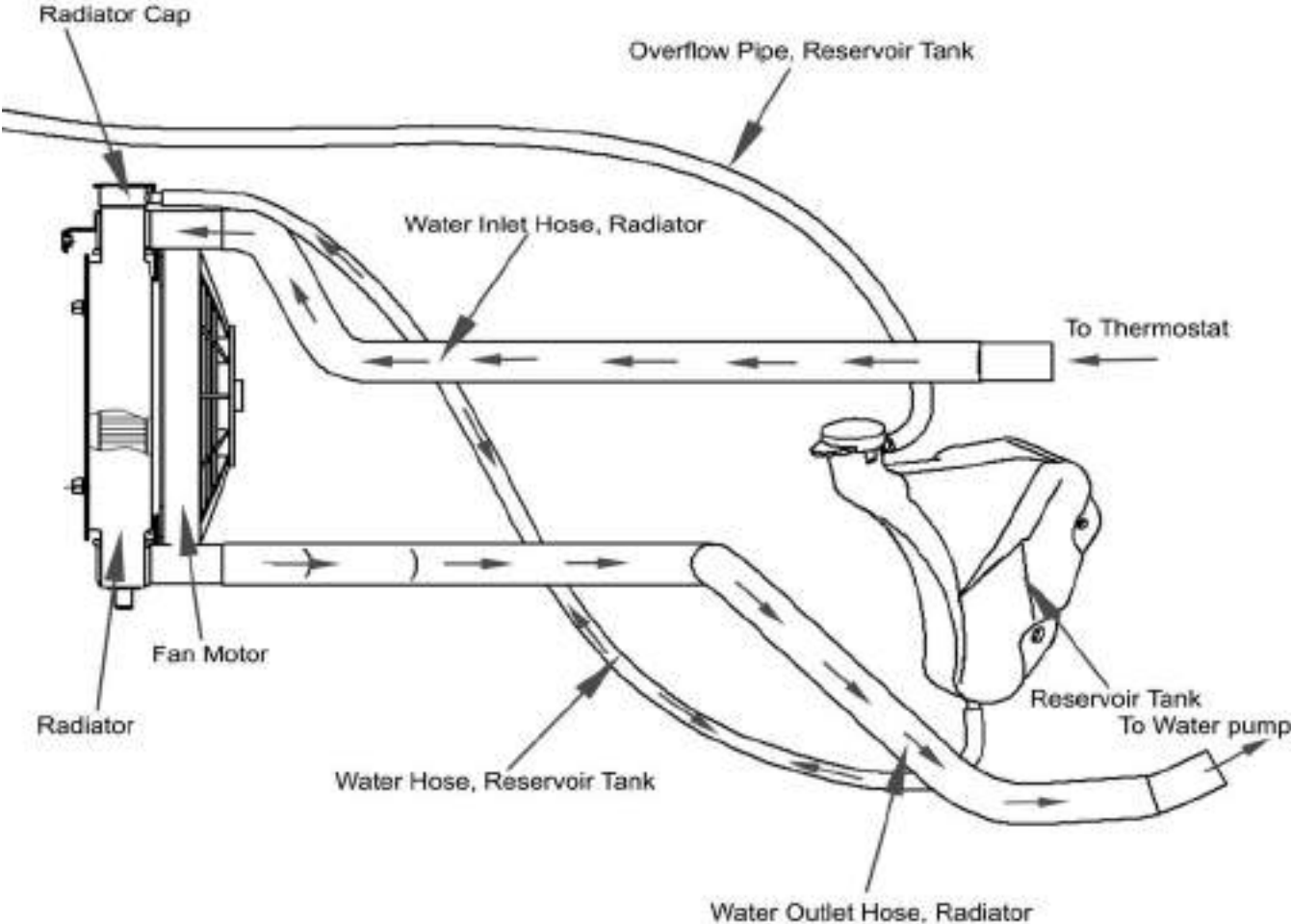

5. Removal and Installation of Engine, Drive Train and Gearshift Unit

Overhaul Info.....	5-1	Removal and Installation of Front and Rear Axle.....	5-5
Engine Removal and Installation.....	5-2	Removal and Installation of Gearshift Unit.....	5-7

Overhaul info

Operation cautions

◆Securely support the ATV with bracket when removing or installing engine.

Take care not to damage frame, engine body, bolts and cables.

◆Wrap the frame to avoid any possible damage when removing or installing the engine.

◆Following operation doesn't require removal of engine from the vehicle:

- Oil pump
- Carburetor, air filter
- Cylinder head cover, cylinder head, cylinder body, camshaft
- CVT system, CVT cover
- Gearbox
- Right side cover, AC magneto, water pump
- Piston, piston ring, piston pin

◆Following operation require removal of engine from vehicle:

- Crankshaft

Tightening torque:

Engine front upper mounting bolt:	35N~45N • m
Engine front rear mounting bolt:	40~50N • m
Bolt, engine front rear mounting bracket	35~45N • m
Bolt, engine front upper mounting bracket	35~45N • m

Engine Removal

Remove:

- Plastic(→ Chapter 2)
- Air Filter(→ Engine service chapter)
- Carburetor (→ Engine service chapter)
- Clamp
- Water Inlet Hose



Water Inlet Hose, Engine Clamp

Remove screw

Remove gearshift rod



Screw

Remove clamp

Remove water outlet hose



Water Outlet Hose, Engine Clamp

Remove Sleeve.

Remove connectors of magneto, enriching device lead, pickup, water temperature transducer, gear sensor as illustrated on the right.



Sleeve

Connectors

5. Removal and Installation of Engine, Drive Train and Gearshift Unit

Remove spark plug cap from cylinder.



Spark Plug Cap

Remove protection sleeve of starter relay.

Remove Nut.

Disconnect positive wire of starter relay.



Positive Wire, Starting Motor

Remove nut.

Remove negative wire of starter relay.



Negative Wire, Starting Motor

Remove Bolt 1 and Nut 1 of upper engine hanger.



Bolt 1,
Upper
Engine
Hanger

Nut 1, Upper Engine Hanger

5. Removal and Installation of Engine, Drive Train and Gearshift Unit

Remove Bolt 2 and Nut 2 of upper engine hanger.

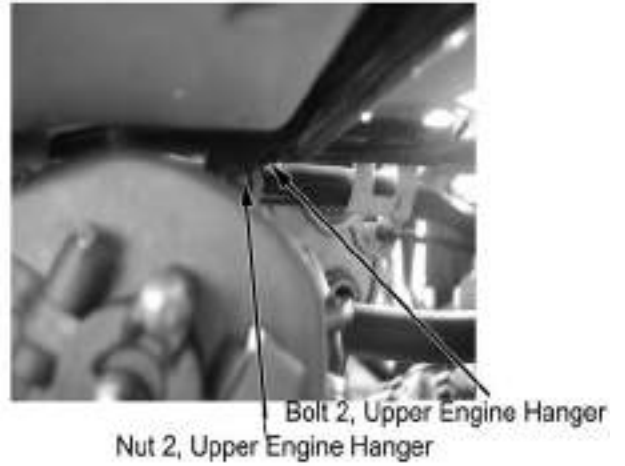

Remove Bolt 1 and Nut 1 of lower engine hanger.

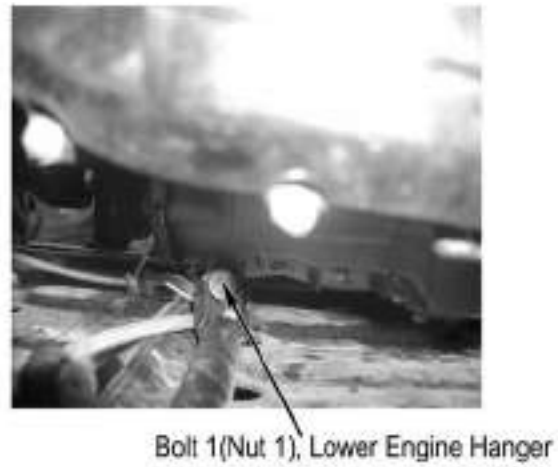

Remove Bolt 2 and Nut 2 of lower engine hanger.

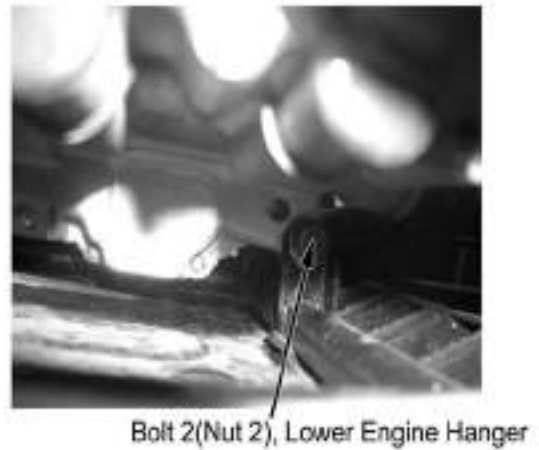

Engine Installation

Put engine onto the frame, install the two lower mounting bolts and nuts. Then install the upper and lower engine hangers.

Tightening torque: Engine upper hanger bolt:35~45N.m
Engine lower hanger bolt:50~60N.m

Install:

- Water outlet and inlet hoses to engine with proper clamps.
- Positive and negative starting wires to engine.
- Connect all the connectors.
- Spark plug cap.
- Gearshift rod to engine.
- Air filter, carburetor and removed parts.

Removal and Installation of Front and Rear Axle

Support the vehicle with jack, make sure the vehicle will not fall.

Remove:

- Plastic parts for frame(→Chapter 2)
- Front and rear wheels and arms(→Chapter 6)
- Air filter(→engine service chapter)
- Carburetor(→engine service chapter)
- Engine
- Rear brake caliper(→7-4)

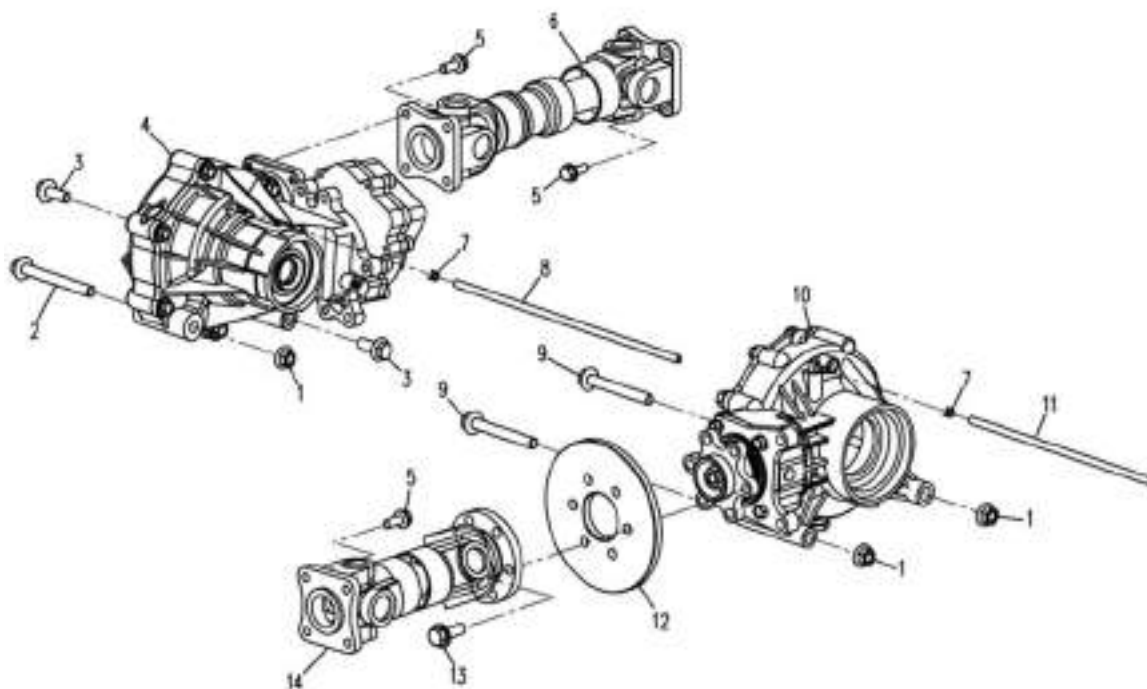

1. Nut 2. Bolt 1 3. Bolt 2 4. Front Axle 5. Bolt 3 6. Front Drive Shaft
7. Clamp 8. Breather Hose, Front Axle 9. Bolt 4 10. Rear Axle
11. Breather Hose, Rear Axle
12. Rear Brake Disk 13. Bolt 5 14. Rear Drive Shaft

5. Removal and Installation of Engine, Drive Train and Gearshift Unit

Remove nut and bolt of front axle from frame.

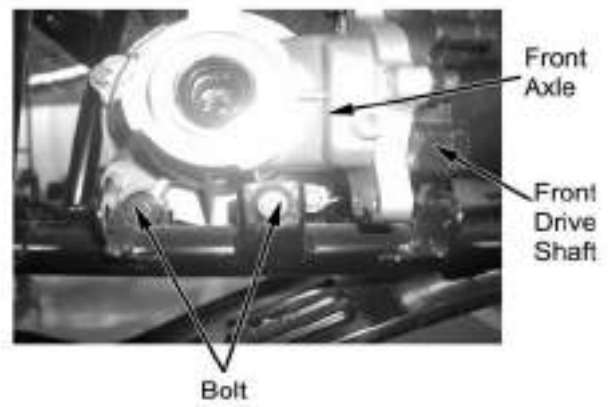
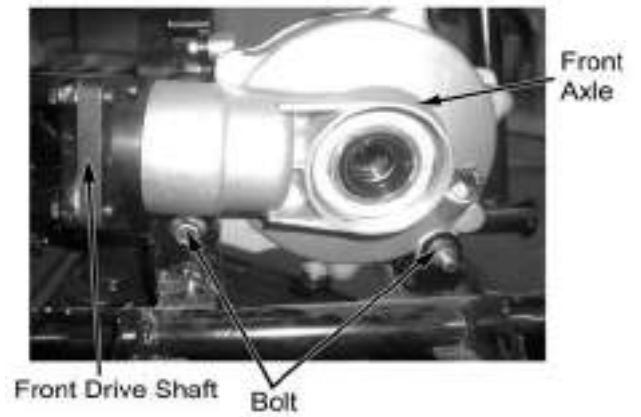

Remove nut and bolt of rear axle from frame.

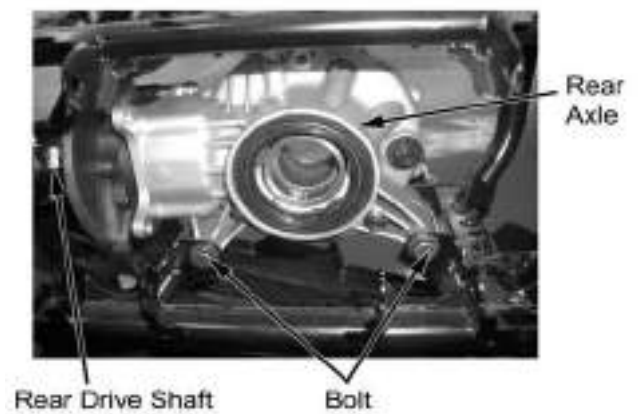
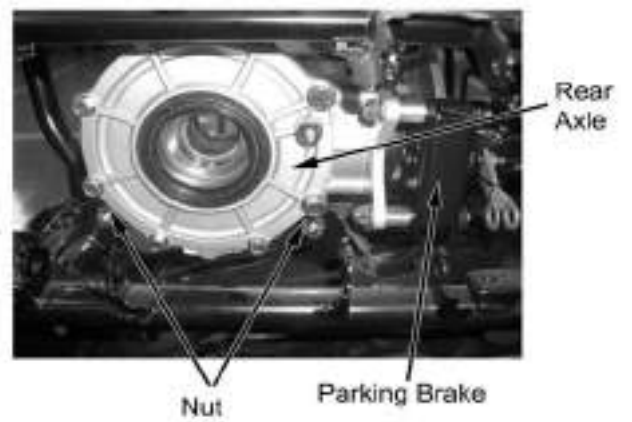

5. Removal and Installation of Engine, Drive Train and Gearshift Unit

Remove the 18 bolts for drive shafts and front and rear axles.
(Refer to P. 5-5, Bolt 3 of Part No.5)

Remove:

--Front and rear axles, drive shafts, rear brake disc

Installation:

Reverse the removal procedure for installation.

Tightening torque:

Bolt, front axle: 40-50N.m

Bolt, rear axle: 40-50N.m

Bolt, front and rear drive shafts: 40-50N.m



Bolt

Gearshift Unit

Remove:

--Left and right side panel (→2-6)

--Fuel tank top cover (→2-8)

--Front fender(→2-8)

--Bolt 1

--Gearshift rod



Gear Shift Rod

Screw

Remove the 2 bolts

Remove gearshift unit

Installation:

Reverse the removal procedure for installation.

Make sure that gearshift is flexible.

In case of any inflexibility, adjust the gearshift rod to ensure the gear engagement.



Bolt

Gear Shift Unit

6. Front Wheel, Front Brake, Suspension, Steering

Overhaul Info.....6-1	Front Brake.....6-4
Troubleshooting6-2	Suspension.....6-7
Front Wheel 6-3	Steering6-12

Overhaul Information

Operating cautions

Notes

- ◆ Securely support the vehicle when overhauling the front wheel and suspension system.
- ◆ Refer to chapter 10 for overhaul and inspection of lighting, instruments and switches.
- ◆ Do not overexert on the wheel. Avoid any damage to the wheel.
- ◆ When removing tire, use the special tire lever and rim protector.

Maintenance Standard

Item		Standard	Service Limit	
	Rim Vibration	Longitudinal	0.8mm	2.0mm
		Lateral	0.8mm	2.0mm
	Tire	Remained groove	--	3.0mm
		Tire Pressure	35kpa(0.35kgf/cm ²)	--
Front brake	Free play (brake lever)	0mm	--	

Tightening torque

Nut, Tie-rod	40-50N.m
Lock nut, steering stem	110-120N.m
Nut, front wheel axle	110N.m
Fixing bolt/nut, absorber	40-50N.m
Nut, front rim	50-60N.m
Nut, front wheel axle	110-130N.m

Special tools

Rod, bearing remover
Head 10mm, bearing remover
Handle A , Driving Tool
Sleeve, Driving Tool 28x30
Guide tool 10mm
Locknut spanner
Bearing remover set
Rotor puller
Remover shaft
Remover hammer
Assembling tool shaft

Troubleshooting

Heavy Steering

- Upper thread is over tightened
- Steering bearing is damaged or worn
- Inner & outer bearing races are damaged, worn or stepped
- Steering stem is distorted
- Tire pressure is too low
- Low tire pressure
- Worn tire

Shaking Handlebar

- Steering bearing is damaged, or not well tightened
- Right and left shock absorbers are not matched
- Deflected tires
- Deformed frame
- Worn tires
- Shaking of wheel bearing

Vibration of Front Wheel

- Wheel rim distorted
- Faulty wheel bearing
- Faulty tire

- Improper tightening of wheel axle
- Improper balance of wheels

Wheel Cannot Turn Freely

- Steering bearing is damaged or worn.
- Front wheel axle is bended
- Brake drag

Front Suspension Is Too Soft

- Weakened front shock absorbers
- Tire pressure is too low

Front Suspension Is Too Hard

- Front shock absorber is bended
- Tire pressure is too high

Noise With Front Absorbers

- Faulty front shock absorbers
- Loosened tightening parts of front shock absorbers

Poor Brake Efficiency

- Faulty brake adjustment
- Stained brake disc
- Worn brake shoes

Front wheel

Removal

Securely support the front wheels

Remove:

- Wheel cap.
- 4 bolt from wheel hub
- Front wheel.

Inspection

Rim

Damage, warpage or serious scrapes:→ Replace

Replace with a new one, if any.

Slowly turn the wheel, measure the rim vibration with a dial gauge.

Service limit: Axial: 2.0mm
Radial: 2.0mm

Assembling:

Press rim into wheel.

Install rim on the wheel hub.

Tightening Torque:

Bolt, Wheel hub: 50-60 N.m

Front Wheel Hub

Disassembly

Remove:

- Front wheel(→6-3)
- Front brake caliper(→6-4)
- Rim axle nut
- Brake disc and wheel hub
- 4 bolts of front brake disc
- Wheel hub

Installation

Reverse the removal procedure for installation

Torque, Rim axle nut: 110-130N.m

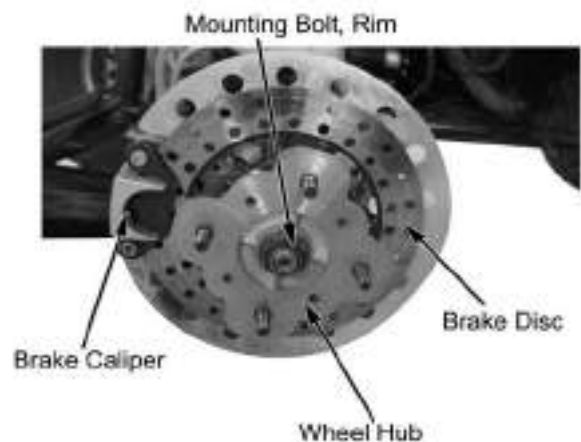

Brake System

Front caliper

Remove:

- Front wheel(→6-3)
- 2 bolts from arm
- Front caliper

Inspection

Check cracks of brake calipers and oil leakage from the tightening parts.

If any, replace.

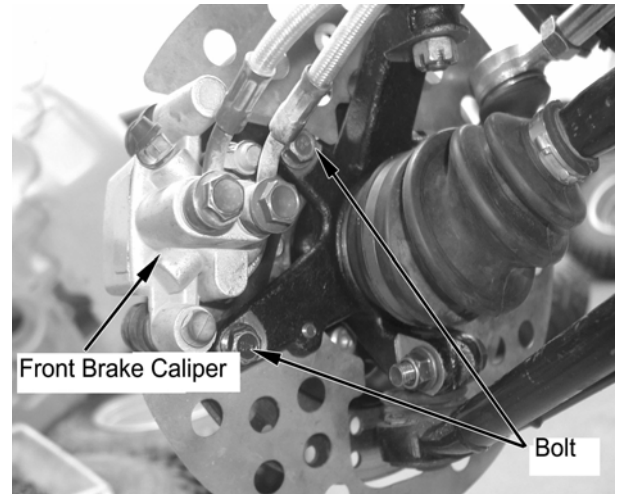

Installation

Reverse the removal procedure for installation.

Tightening Torque

Fixing Bolt, Brake Caliper: 40-50N.m

Brake disc

Remove:

- Front wheel (→6-3)
- Brake caliper(→6-4)
- Front brake disc and wheel hub
- 4 bolts from brake disc
- Brake disc.

Inspection:

Brake disc thickness: < 2.5mm→ Replace

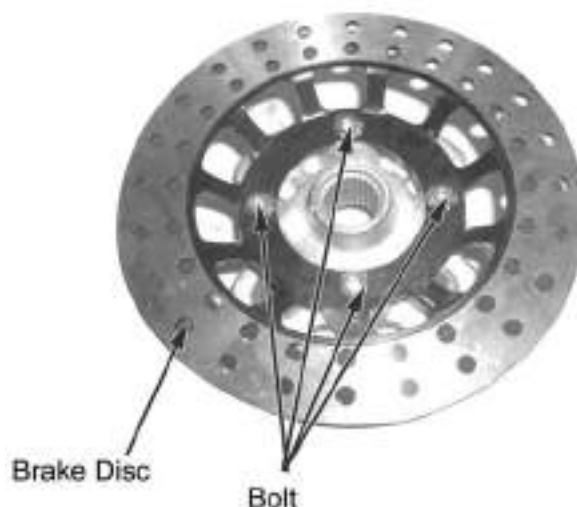

Installation

Install brake disc

Fixing bolt, brake disc: 25-30N.m

Front Brake Master Cylinder

Disassembly

Remove Bolt 1, Bolt 2

Separate front brake master cylinder from handlebar

Do not remove front brake master cylinder from vehicle unless when replacing master cylinder assembly.

NOTE:

Do not hang master cylinder on braking hose.

Do not put the master cylinder upside down to avoid possible entrance of air into brake system.

Keep the master cylinder in the installation position and fix it to the handlebar.

Refer to Chapter 1 for proper routing of brake hose.

Check brake efficiency after installation.

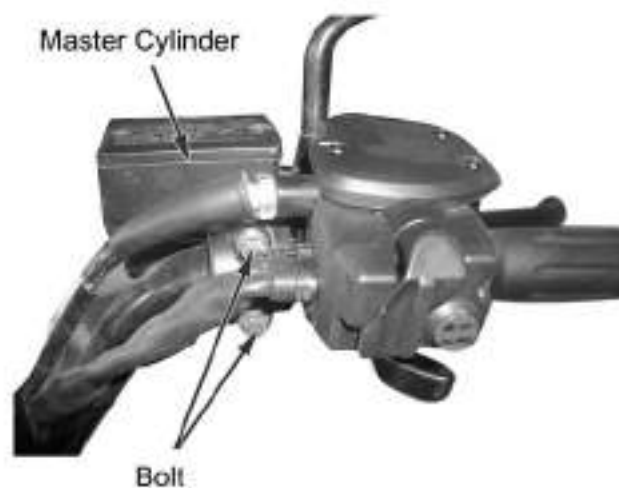

Disassembly

Remove:

- Footrest board(→2-9)
- Front right inner fender (→2-12)
- Bolt 1, Bolt 2

Separate foot brake master cylinder from vehicle

Assembly

Reverse the removal procedure for installation.

NOTE

Do not put the master cylinder upside down to avoid possible entrance of air into brake system.

Keep the master cylinder in the installation position and fix it to the frame.

Refer to Chapter 1 for proper routing of brake hose.

Check brake efficiency after installation.

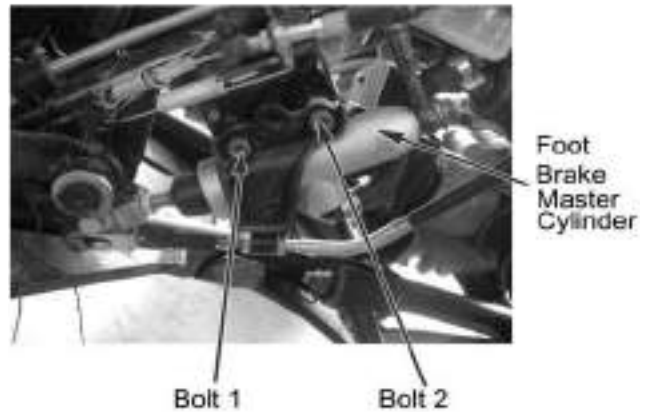

Brake Hose T-Pipe

Remove:

- Front right inner fender (→2-12)
- Bolt 1
- T-Pipe

Installation

Reverse the removal procedure for installation

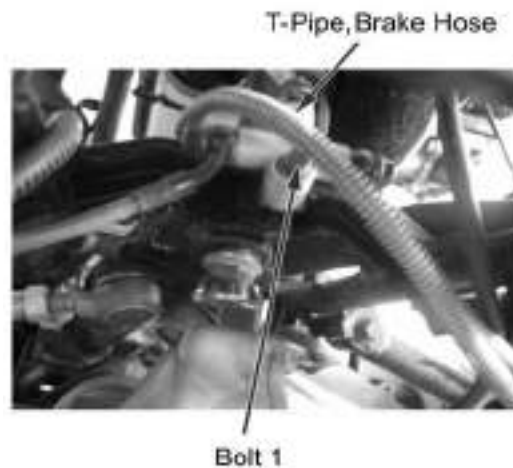

Note:

Check front and rear brake linkage after installation.

Brake Hose Cross Pipe

Remove:

- Front right inner fender (→2-12)
- Bolt 1, Bolt 2
- Brake hose cross pipe

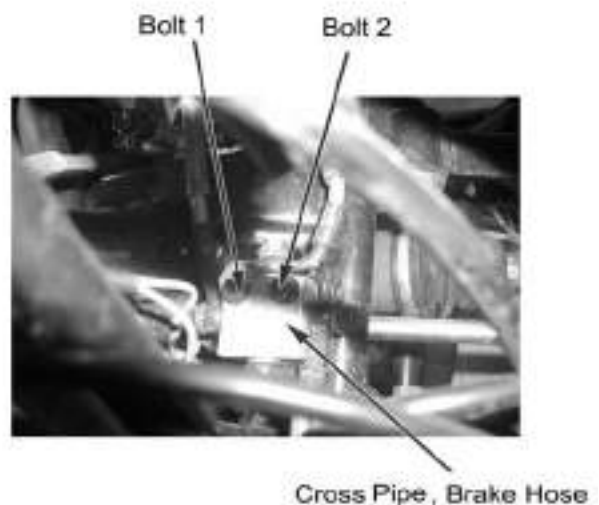

Installation

Reverse the removal procedure for installation.

NOTE

Note:

Check front and rear brake linkage after installation.

Front Suspension system

Front left Suspension

NOTE

DO NOT remove both left and right suspension at the same time to avoid fall down of the vehicle.

Park the vehicle on a level ground and securely support front part of the vehicle.

Removal:

- Front wheel (→6-3)
- Front wheel hub (→6-3)
- Front brake caliper(→6-4)
- Bolt 1, Nut 1

--Bolt 2, Nut 2

--Bolt 3, Nut 3, Bolt 4, Nut 4

Remove slotted nut.

Remove tie-rod.

Pull out steering knuckle from CV joint.

Remove front left suspension.

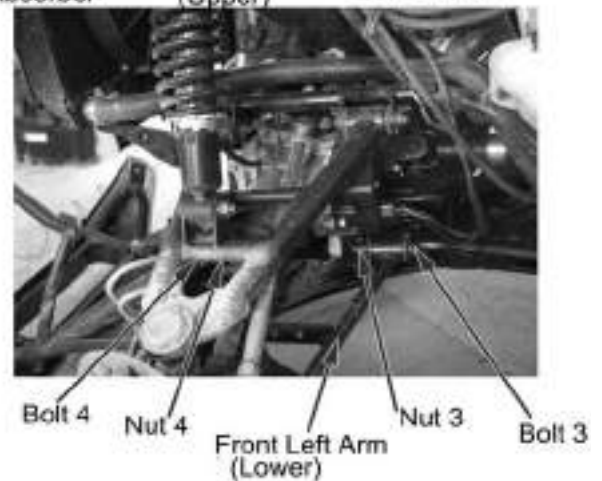
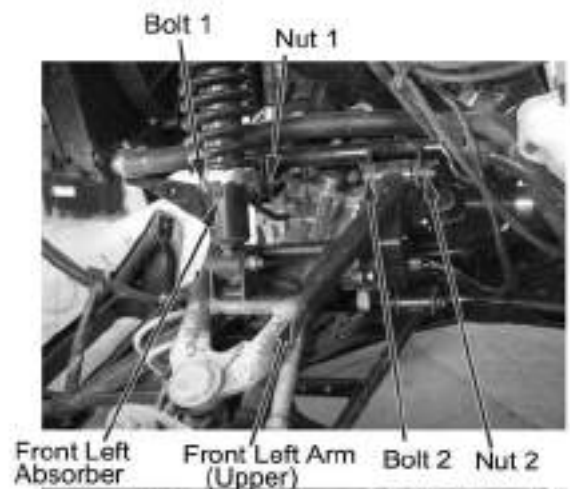
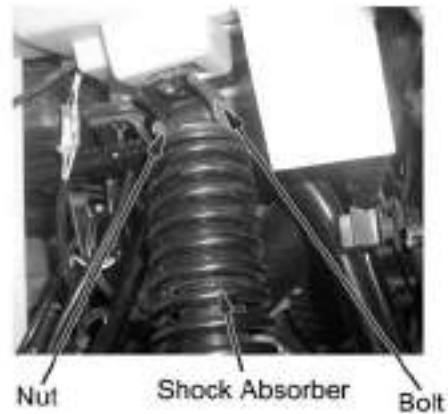

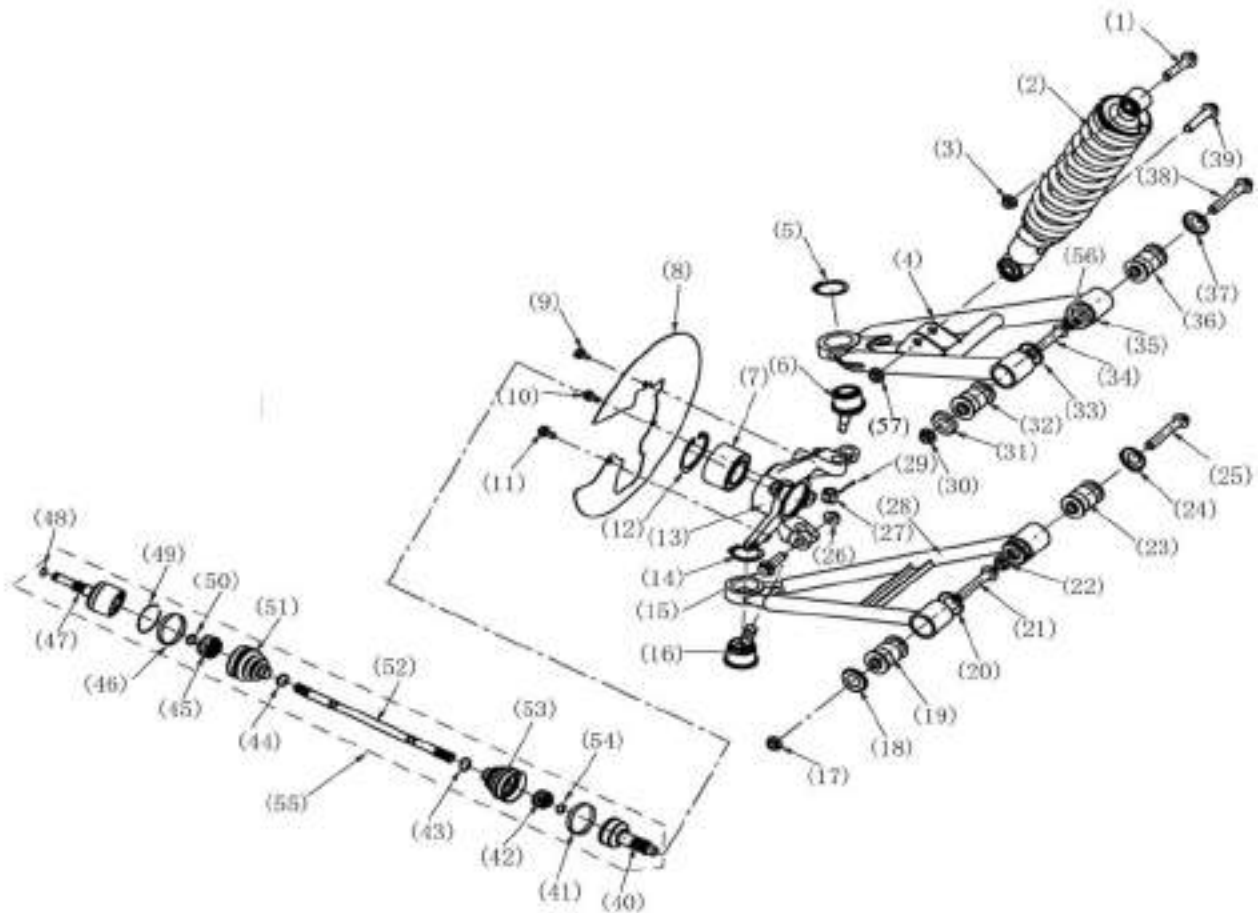

- | | | |
|------------------------------|---|------------|
| (1) Bolt 1 | (29) Cotter pin | (56) Nut 7 |
| (2) Front right absorber | (30) Nut 5 | (57) Nut 8 |
| (3) Nut 1 | (31) Cap, buffering collar | |
| (4) Front right arm (upper) | (32) Buffering collar | |
| (5) Circlip, bearing | (33) Cap, buffering collar | |
| (6) Upper ball pin | (34) Bolt 8 | |
| (7) Bearing, hub | (35) Nut 6 | |
| (8) Brake disc guard | (36) Buffering collar | |
| (9) Bolt 2 | (37) Cap, buffering collar | |
| (10) Bolt 3 | (38) Bolt 9 | |
| (11) Bolt 4 | (39) Bolt 10 | |
| (12) Circlip | (40) Rzeppa universal joint | |
| (13) Right steering knuckle | (41) Big clamp, fixed end | |
| (14) Circlip | (42) Bearing, fixed end | |
| (15) Bolt 5 | (43) Small clamp, fixed end | |
| (16) Bottom ball pin | (44) Small clamp, fixed end | |
| (17) Nut 2 | (45) Bearing, motion end | |
| (18) Cap, buffering collar | (46) Big clamp, motion end | |
| (19) Buffering collar | (47) Rzeppa universal joint | |
| (20) Bolt 6 | (48) Wire circlip | |
| (21) Bolt 3 | (49) Wire circlip 2 | |
| (22) Nut 3 | (50) Spacing shim | |
| (23) Cap, buffering collar | (51) Dust boot, motion end | |
| (24) Buffering collar | (52) Front left shaft | |
| (25) Bolt 7 | (53) Dust boot, fixed end | |
| (26) Bolt 4 | (54) Wire clamp I | |
| (27) Slotted nut | (55) Left CV drive shaft left, front axle | |
| (28) Front right arm (lower) | | |

Disassembly:

Note: Replacing the front shock absorber does not require removal of other parts.

Remove Bolt 10 (39) and Nut 8 (57)

Remove front right shock absorber

Inspection:

Oil leakage, aged oil seal, damage → **Replace**

Installation:

Reverse the removal procedure for installation.

Refer to **Front Right Shock Absorber** for disassembly, installation and inspection of **Front Left Absorber**.

Suspension Arms

Note: This vehicle has 8 suspension arms. The removal, disassembly, inspection and installation of the 8 arms are the same.

This service manual will only introduce the removal, disassembly, inspection and installation of **Front Left Upper Arm, Front Left Lower Arm**.

Refer to **Front Left Upper Arm, Front Left Lower Arm** for removal, disassembly, inspection and installation of other suspension arms.

Front Right Arm

Disassembly

Remove:

- Front right absorber (→6-8)
- Bolt 9 (38) and Nut 7 (56);
- Bolt 8 (34) and Nut 5 (30)
- Bolt 7 (25) and Nut 3 (22)
- Bolt 6 (21) and Nut 2 (17)

Remove wheel, brake caliper and wheel hub before removing absorber;

Remove tie-rod before removing bolts;

Pull out steering knuckle from CV drive shaft before removing front right arm.

Inspection

Ball Pin

Check if Upper Ball Pin (6) for Front Right Upper Arm (4) and Lower Ball Pin for Front Right Lower Arm (28) can turn freely in all directions.

Check clearance of upper and lower ball pins.

Clearance out of range, no free turning: → **Replace Ball pin**

Right Steering Knuckle

Inspection:

Damaged steering knuckle: → Replace

Check wheel hub bearing for free turning and clearance.

Bearing cannot turn freely or clearance out of range: → **Replace**

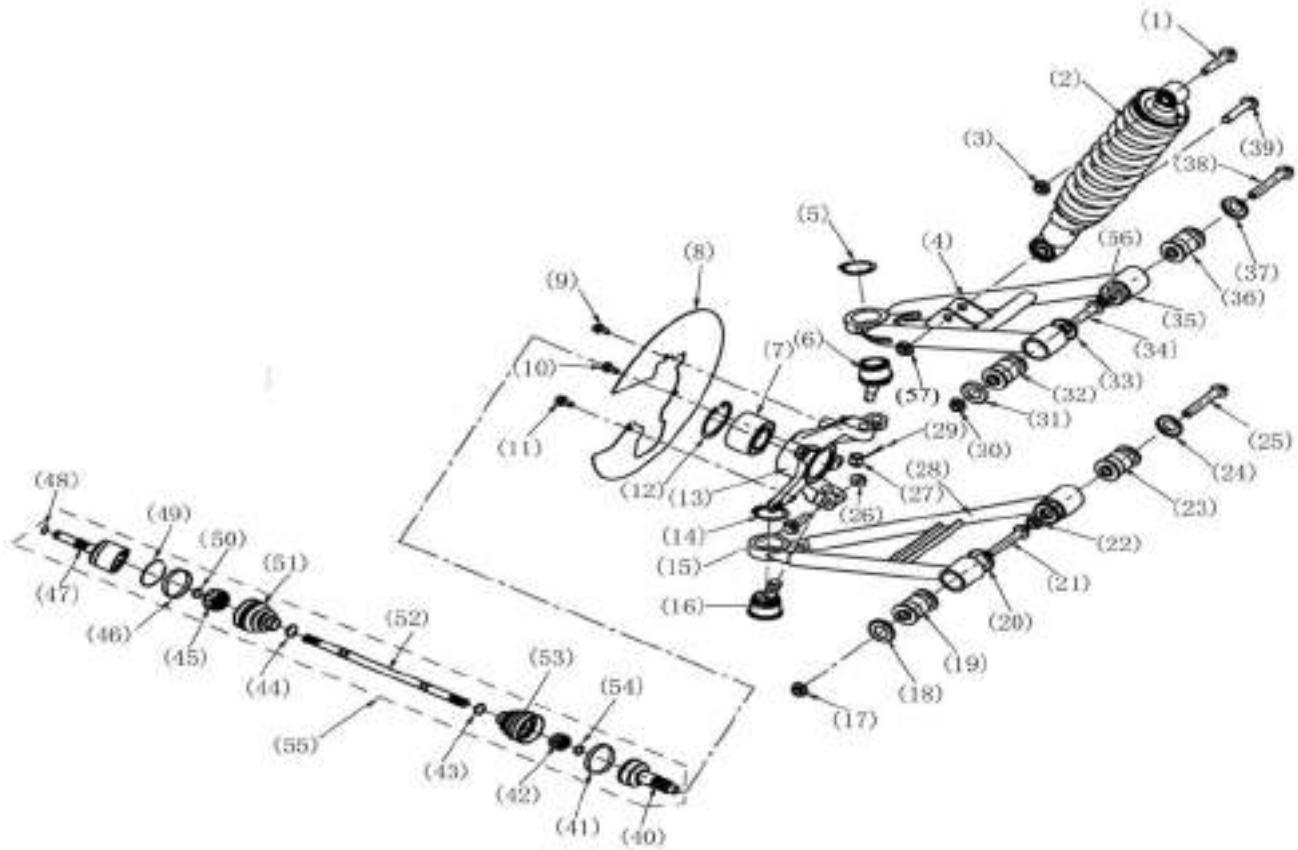

- | | | |
|-----------------------------|------------------------------|---|
| (1) Bolt 1 | (23) Cap, buffering collar | (45) Bearing, motion end |
| (2) Front right absorber | (24) Buffering collar | (46) Big clamp, motion end |
| (3) Nut 1 | (25) Bolt 7 | (47) Rzeppa universal joint |
| (4) Front right arm (upper) | (26) Bolt 4 | (48) Wire circlip |
| (5) Circlip, bearing | (27) Slotted nut | (49) Wire circlip 2 |
| (6) Upper ball pin | (28) Front right arm (lower) | (50) Spacing shim |
| (7) Bearing, hub | (29) Cotter pin | (51) Dust boot, motion end |
| (8) Brake disc guard | (30) Nut 5 | (52) Front left shaft |
| (9) Bolt 2 | (31) Cap, buffering collar | (53) Dust boot, fixed end |
| (10) Bolt 3 | (32) Buffering collar | (54) Wire clamp I |
| (11) Bolt 4 | (33) Cap, buffering collar | (55) Left CV drive shaft left, front axle |
| (12) Circlip | (34) Bolt 8 | (56) Nut 7 |
| (13) Right Steering Knuckle | (35) Nut 6 | |
| (14) Circlip | (36) Buffering collar | |
| (15) Bolt 5 | (37) Cap, buffering collar | |
| (16) Bottom ball pin | (38) Bolt 9 | |
| (17) Nut 2 | (39) Bolt 10 | |
| (18) Cap, buffering collar | (40) Rzeppa universal joint | |
| (19) Buffering collar | (41) Big clamp, fixed end | |
| (20) Bolt 6 | (42) Bearing, fixed end | |
| (21) Bolt 3 | (43) Small clamp, fixed end | |
| (22) Nut 3 | (44) Small clamp, fixed end | |

Constant Velocity Drive Shafts

NOTE: The disassembly, inspection and installation of left and right constant velocity drive shafts of front rear axles are the same.

The following will give instruction only on the disassembly, inspection, installation of Left Constant Velocity Drive Shaft of front axle.

Refer to Left Constant Velocity Drive Shaft for disassembly, inspection, installation of other drive shafts.

(55)Left Constant Velocity Drive Shaft, Front Axle

Disassembly

NOTE: Maintenance of Left Constant Velocity Drive Shaft of front axle only does not require removal of front suspension.

Remove:

--Front wheel(→6-3)

--Front left brake caliper(→6-4)

--Front left wheel hub (→6-3)

Check dust boot.

Damaged dust boot: → Replace

Shake constant velocity drive shaft, check the agility of rzeppa universal joint, free turning of bearing, and any gap between rzeppa constant velocity joint and spline.

Stagnated turning, noise, gap with spline: →Replace

Warning:

An accident may occur if the rzeppa constant velocity joint cannot run freely because of the loss of control of wheel steering.

Installation

Press ball pin into arm with special tool.

Reverse the removal procedure for installation.

Note:

There should be no rocking or sway with the installed left and right arms.

Tightening Torque: 40~50 N•m

Steering system

Handlebar

Dashboard Front Cover

Disassembly

Remove

-- 2 tapping screws.



--Bolt1

--Dashboard front cover

Installation:

Reverse the removal procedure for installation

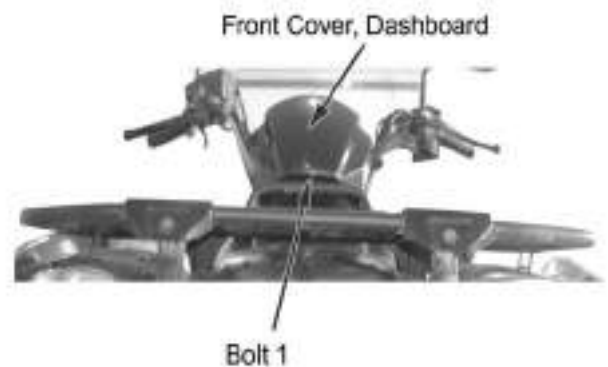

Right Handlebar Switch

Remove:

--Front top cover (→2-4)

--Right handlebar switch connector

--2 bolts

--Right handlebar switch

Installation:

Install right handlebar switch (→6-15)

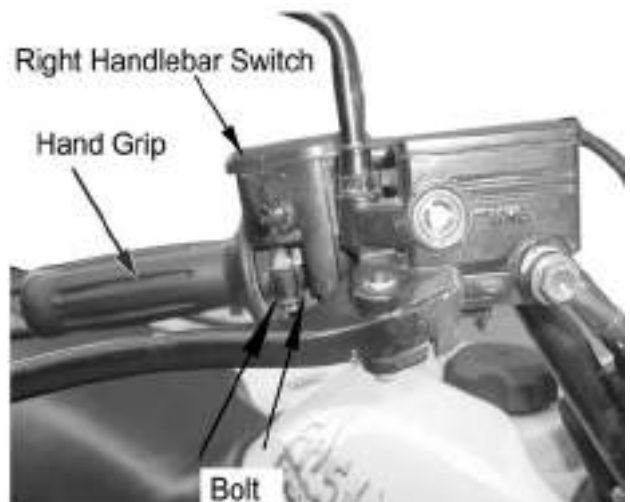

Left Handlebar Switch

Disassembly

Remove

- 2 screws
- Left handlebar switch connector
- Left handlebar switch

Installation

Install left handlebar switch (→6-15)



Rear View Mirror

Disassembly

Turn counter clockwise and loosen nut,
Remove left rear view mirror by turning it counter clockwise.

Note:

Left rear view mirror is right-threaded.

Turn counter clockwise for removal.



Connector, Handlebar Switch

Turn clockwise and loosen nut,
Remove right rear view mirror by turning it clockwise.

Note:

Right rear view mirror is left-threaded.

Turn clockwise for removal.

Installation:

Reverse the removal procedure for installation



Handlebar, Dashboard Rear Cover

Disassembly

Remove:

- Dashboard front cover (→6-12)
- Left & right handlebar switch (→6-12)

Separate left & right master cylinders from handlebar

Remove:

- Screw1, Screw2
- Dashboard rear cover
- 4 fixing bolts
- Handlebar

Installation

Reverse the removal procedure for installation

Tightening Torque: 20-30N.m (2.0-3.0kgf.m)

Note

Main cable, throttle cable, brake hose, cable wiring should be routed properly

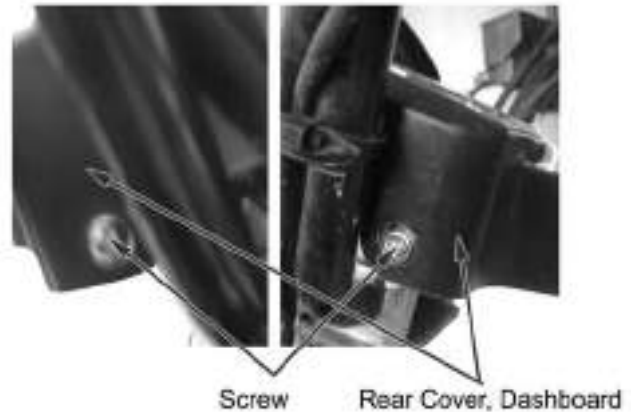

Installation of Throttle Cable

Remove:

- 3 screws
- Right handlebar top cover

Install:

- Throttle cable
- Right handlebar switch top cover

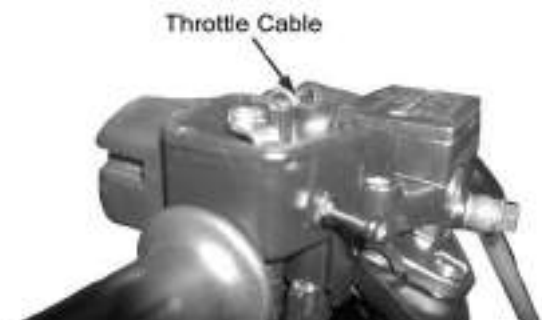

Installation of Left Handlebar Switch

Match the limit pin of left handlebar switch with positioning hole on handlebar.,

Tighten with Screw 1 and 2 from under

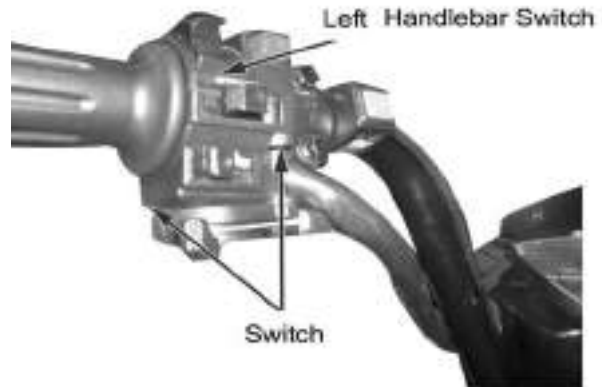

Insert connector of left handlebar switch into socket of main cable

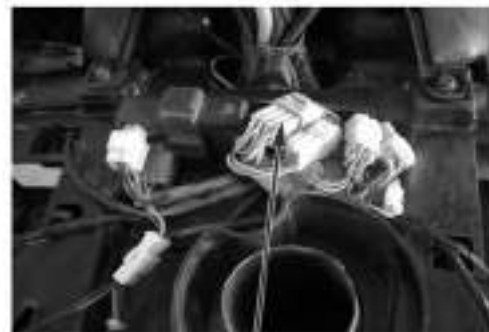

Connector, Handlebar Switch

Installation of Right Handlebar Switch

Match the limit pin of right handlebar switch with positioning hole on handlebar.

Tighten with Screw 1 and 2 from under.



Insert connector of right handlebar switch into socket of main cable.

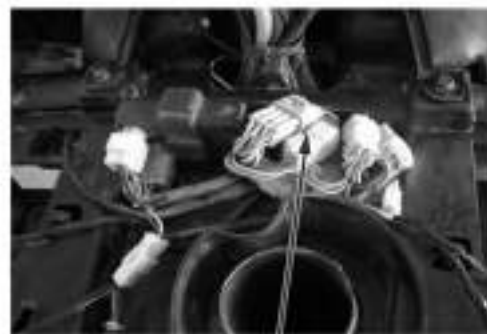

Connector, Handlebar Switch

Installation of Left and Right Grip

Clean off stains and grease from handlebar and inner left and right grips.

Dry completely.

Apply glue between handlebar and left and right grips.

Install left and right grips.

NOTE:

Wait several hours till the glue dries after the left and right grips are installed.



Installation of Master Cylinder

Keep the UP mark on master cylinder upward.

Install master cylinder.

NOTE:

Main cable, throttle cable, brake hose and wiring should be routed properly.

Install:

--Rear view mirror(→6-13)

--Dashboard(→6-10)

--Dashboard front and rear cover(→6-14)

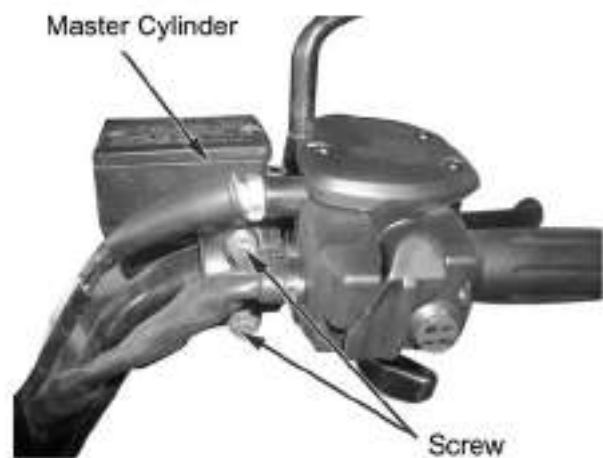

Steering System

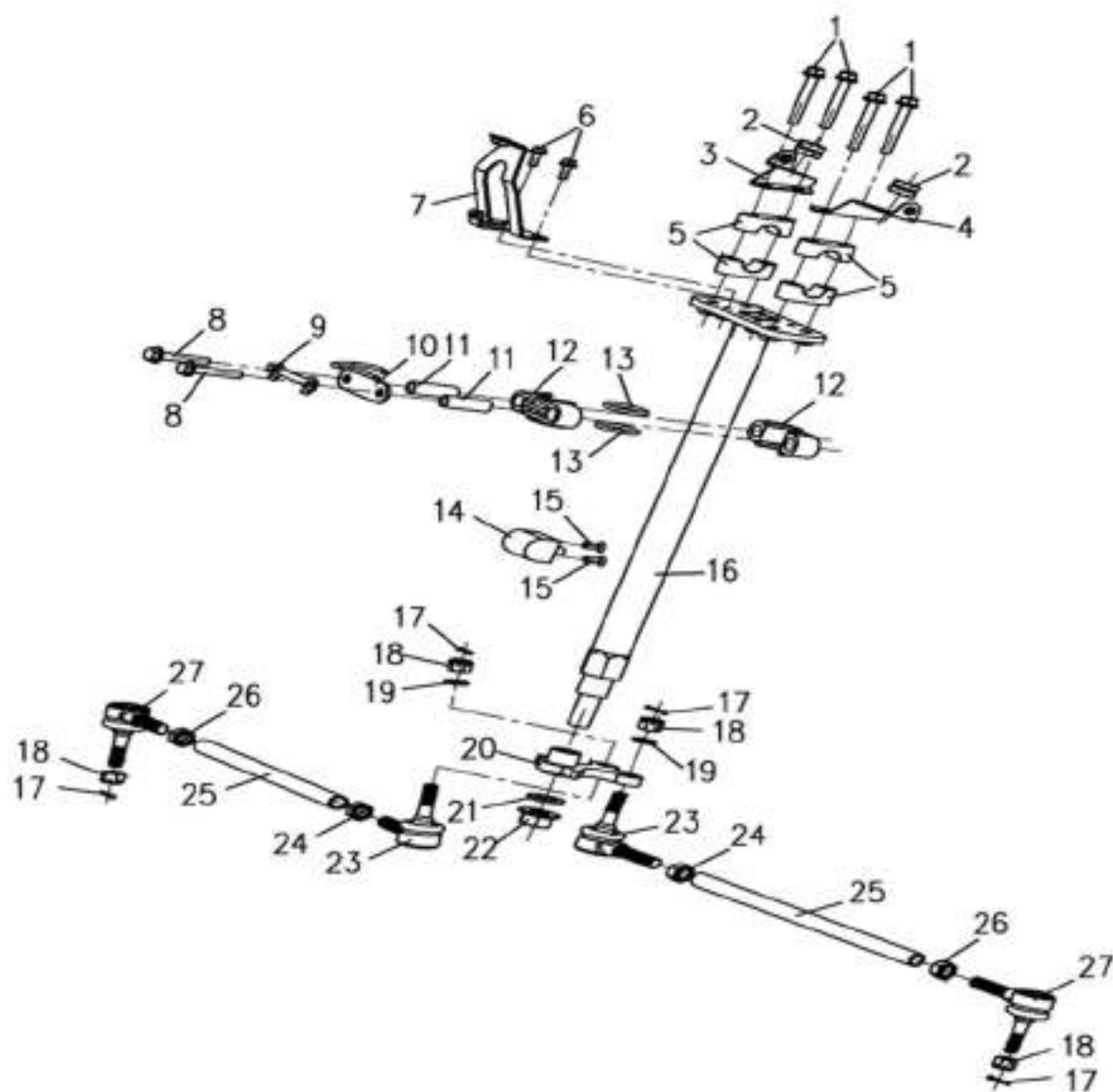

- | | | |
|-----------------------------|------------------------|------------------------|
| 1 Bolt 1 | 13, Seal Ring | 25, Tie-Rod |
| 2 Rubber | 14, Steering Lock | 26, Nut 4 |
| 3, Right Bracket, Dashboard | 15, Screw 2 | 27, Steering Knuckle 2 |
| 4, Left Bracket, Dashboard | 17, Cotter Pin | |
| 5, Alum Cover, Handlebar | 18, Nut 1 | |
| 6, Bolt 2 | 19, Washer 1 | |
| 7, Front Bracket, Dashboard | 20, Pitman Arm | |
| 8, Bolt 3 | 21, Washer 2 | |
| 9, Lock Pad | 22, Nut 2 | |
| 10, Adapter Plate | 23, Steering Knuckle 1 | |
| 11, Bush | 24, Nut 3 | |
| 12, Bushing, Steering Stem | | |

6. Front Wheel, Front Brake, Suspension, Steering

Steering Stem

Remove:

- Dashboard front cover(→6-12)
- Front wheel (→6-2)

Disconnect handlebar switch connector

Hammer the lock pad flat with a flat screwdriver and hammer

Remove:

- Bolt 1 and Bolt 2
- Steering stem bushing, adapter plate

- Cotter pin
- Tie-rod nut and washer

Press down steering tie-rod and separate from steering stem

Remove fixing bolt of steering stem

Lift steering stem with handlebar from vehicle.

Installation:

Reverse the removal procedure for installation

NOTE:

Check steering after installation (3-3)

Main cables and wires shall be routed properly (chapter 1)

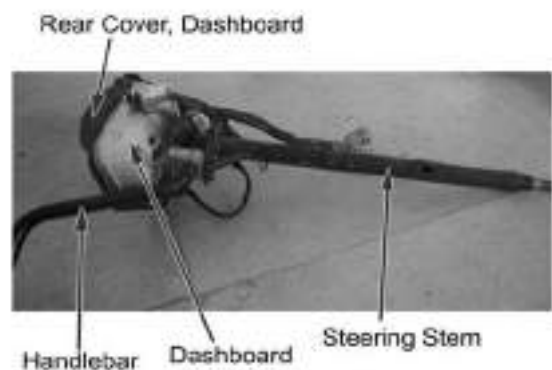
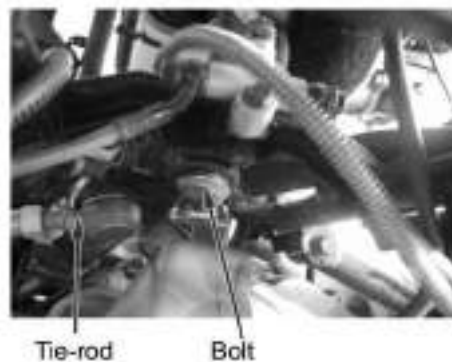
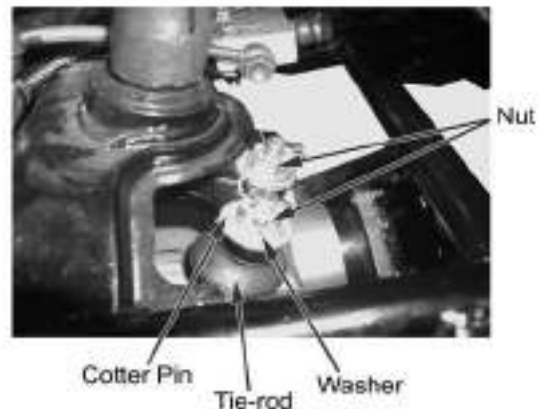
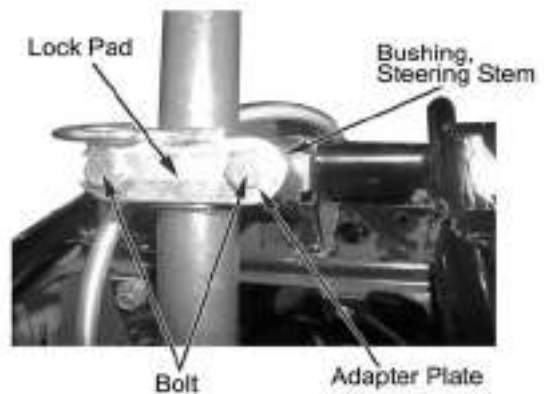

Steering Bearing, Oil Seal

Remove:

- Front wheel (→6-2)
- Steering stem (→6-18)

Remove front left & right arms(upper & lower)(→6-9)

Remove steering bearing and oil seal from frame with special tool

Special tools:

- Bearing removal tool set
- Rotor puller
- Removal tool shaft
- Removal tool hammer

Installation

Reverse the removal procedure for installation.

Special tools:

- Tool A, Bearing Race
- Tool shaft

Note:

Use special tools for installation of bearing.

Reverse the removal procedure for installation of the steering system.

NOTE:

Check steering after installation.

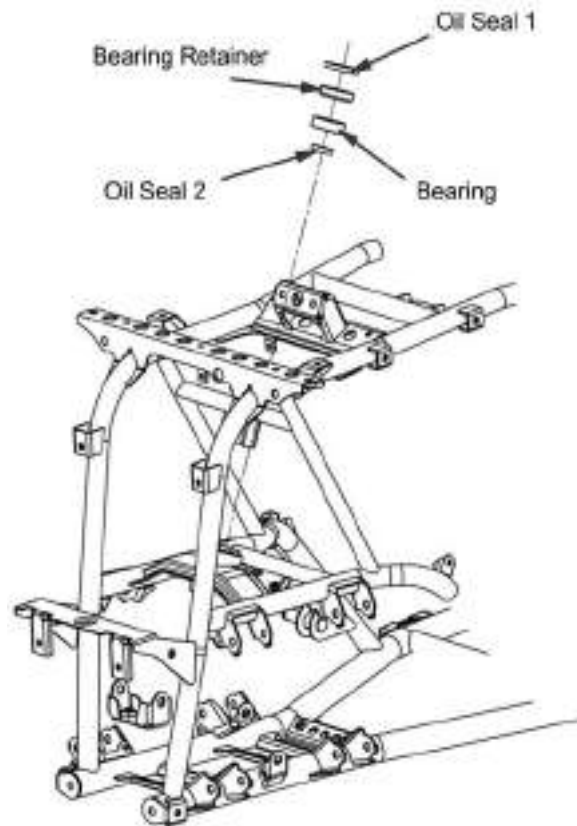

7. Rear Wheel, Rear Brake, Suspension

Overhaul Info.....	7-1
Troubleshooting.....	7-2
Rear Wheel.....	7-3

Rear Fork.....	7-4
Rear Shock Absorber.....	7-5

Overhaul information

Note

- ◆ Securely support the vehicle when overhauling the rim and suspension system.
- ◆ Use genuine parts of bolts and nuts for rear rim and suspension.
- ◆ Do not overexert on the wheels to avoid possible damage to the wheels.
- ◆ When removing tire from rim, use special tire lever and rim protector to avoid damage to the rim.

Overhaul standard

Item		Standard	Limit
Rear Wheel	Rim Vibration	Longitudinal	—
		Horizontal	—
	Tire	Remained Tire Tread	—
		Tire Pressure	35kpa(0.35kgf/cm ²)
Rear Brake	Brake Lever Free Play	10—20mm	—

Tightening torque

Rear wheel axle nut	110-130N•m
Rim mounting bolt	50-60N•m
Upper mounting bolt, Shock absorber	40-50N•m
Lower mounting bolt, Shock absorber	40-50N•m

Troubleshooting

Rear Wheel Wobbles

- Rim warpage
- Faulty tire.
- Tire pressure too low
- Improper wheel balance
- Improper tightening of wheel axle nut
- Loosened wheel nut

Rear Shock Absorber Is Too Soft

- Weak spring.
- Oil leakage from rear shock absorber

Rear Shock Absorber Is Too Hard.

- Bent rear shock absorber
- Tire pressure is too high

Poor Brake Efficiency

- Improper brake adjustment
- Stained brake pad or brake disk
- Worn or damaged brake pad

Rear Wheel

Removal:

Refer to front wheel removal (→6-3)

Inspection:

Rim:

Damage, warpage, serious scrapes:→ Replace

Slowly turn the wheel, measure the rim vibration with a dial gauge.

Service limit: Axial: 2.0mm
Radial: 2.0mm

Installation:

Refer to front wheel installation (→6-3)

Wheel Hub

Remove:

- Rear wheel (→7-3)
- Rim axle nut
- Wheel Hub

Installation:

Reverse the removal procedure for installation.

Tightening torque, Rim Axle Nut: 110-130N.m

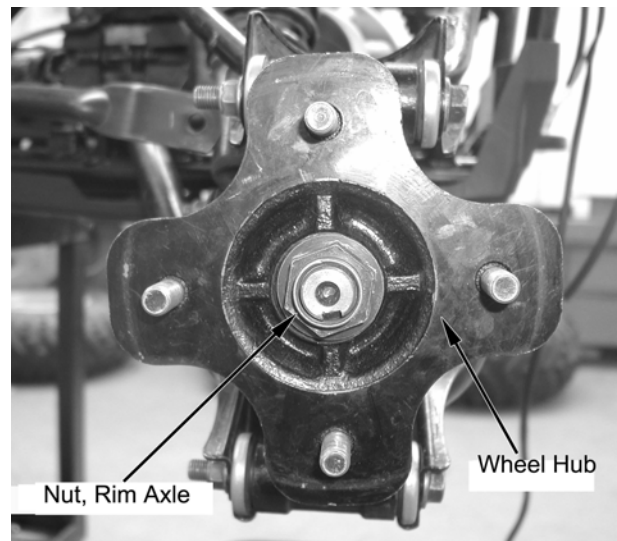

Rear Brake

Rear Brake Caliper

Remove:

- Rear left wheel (→7-3)
- 2 bolts from arm
- Brake caliper

Inspection:

Brake Caliper: Cracks, Oil leakage: →Replace

Installation

Reverse the removal procedure for installation.

Note:

Refer to Chapter 1 for brake hose routing.

Rear Brake Disc

Remove:

- Rear left wheel (→7-3)
- Rear drive shaft
- Rear brake caliper (→7-4)
- 6 shear bolts
- Parking brake (→7-4)
- Rear brake disc (→6-3)

Inspection

Brake Disc: Thickness < 6.5mm: → Replace

Installation

Reverse the steps of removal for installation.

Note:

Refer to Chapter 1 for brake hose routing.

Parking Brake

Remove:

- Rear left wheel (→7-3)
- Rear drive shaft
- Rear brake caliper (→7-4)
- 6 shear bolts
- Parking brake

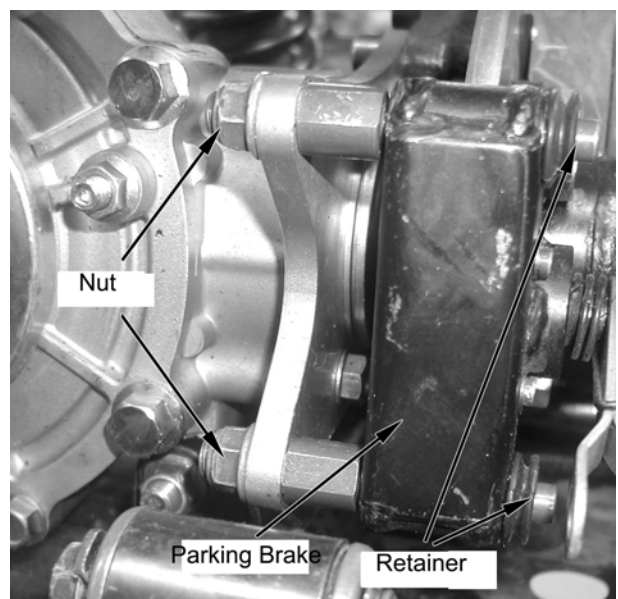
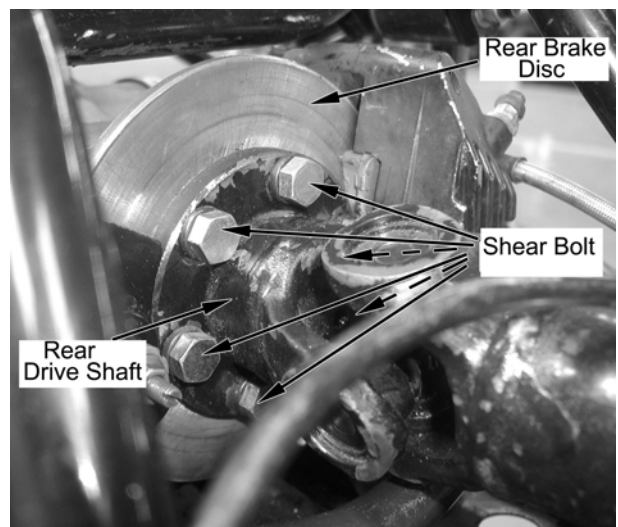
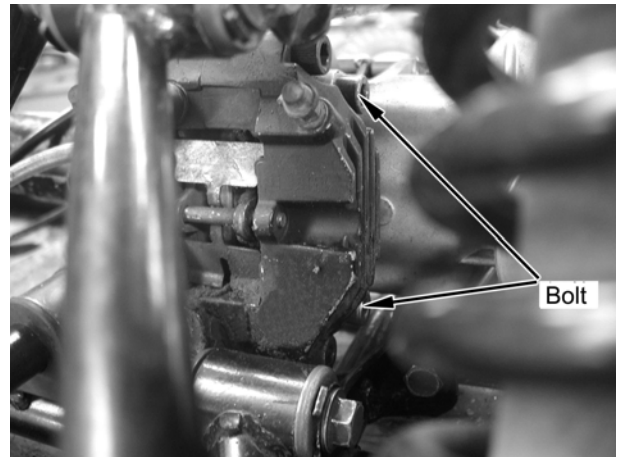

Rear Suspension System

Rear Right Suspension

NOTE

DO NOT remove both left and right suspension at the same time to avoid fall down of the vehicle.

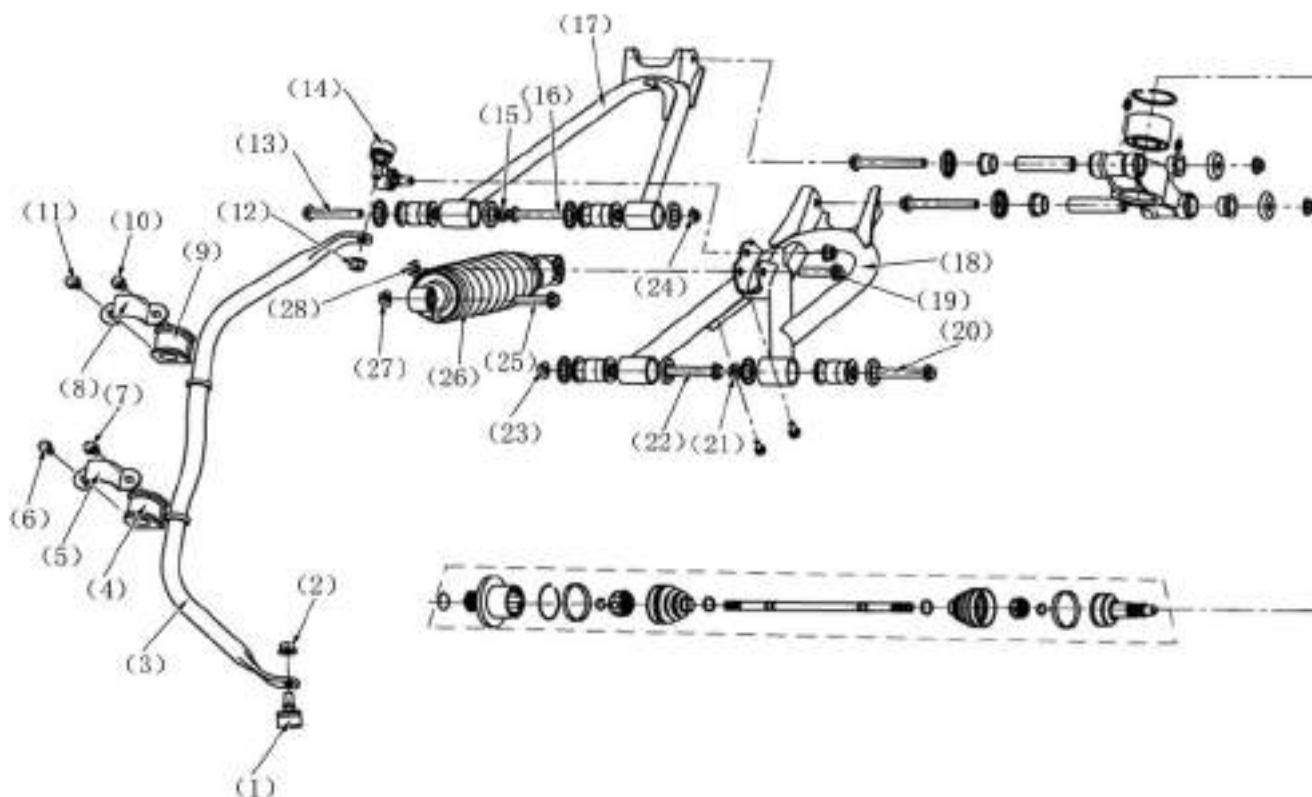

- | | | |
|------------------------------------|---------------------------|--------------------------|
| (1) Left Ball Pin | (11) Bolt 4 | (21) Nut 4 |
| (2) Nut 1 | (12) Nut 2 | (22) Bolt 9 |
| (3) Stabilizer Bar | (13) Bolt 5 | (23) Nut 5 |
| (4) Rubber Support, Right Rear Arm | (14) Right Ball Pin | (24) Nut 6 |
| (5) Bracket | (15) Nut 3 | (25) Bolt 10 |
| (6) Bolt 1 | (16) Bolt 6 | (26) Rear Right Absorber |
| (7) Bolt 2 | (17) Rear Right Upper Arm | (27) Nut 7 |
| (8) Bracket | (18) Rear Right Lower Arm | (28) Nut 8 |
| (9) Rubber Support | (19) Bolt 7 | |
| (10) Bolt 3 | (20) Bolt 8 | |

Disassembly

Stabilizer Bar

Remove:

Bolt 1(6), Bolt 2 (7), Bolt 3 (10), Bolt 4 (11), Bracket (8)and(5), Rubber Support (4) and (9), Nut 2 (2), Nut 10 (12), Left Ball Pin (1), Right Ball Pin (14)

Remove: Stabilizer Bar (3)

Installation:

Reverse the removal procedure for installation

Right Rear Absorber

Removal

Note: Securely support the vehicle when removing rear left and right absorbers. Suspend wheels from ground.

Maintenance of rear absorbers only does not require removal of rear suspension.

Remove the following parts for rear right shock absorber

- (25) Bolt 10
- (27) Nut 7
- (19) Bolt 7
- (28) Nut 8

Remove rear right shock absorber

Installation:

Reverse the removal procedure for installation.

Rear Right Arm

Refer to **Front Left Upper Arm** in Chapter 13 for the removal, inspection and installation of **Rear Right Arm**

Rear Left Suspension

Refer to **Rear Right Suspension** for the removal, inspection and installation of **Rear Left Suspension**.

Charging System Layout.....	8-1	Inspection of Charging System... ..	8-5
Overhaul Info.....	8-2	Rectifier/Regulator.....	8-6
Troubleshooting	8-3	Inspection of AC Magneto.....	8-8
Battery.....	8-4		

Charging System Layout

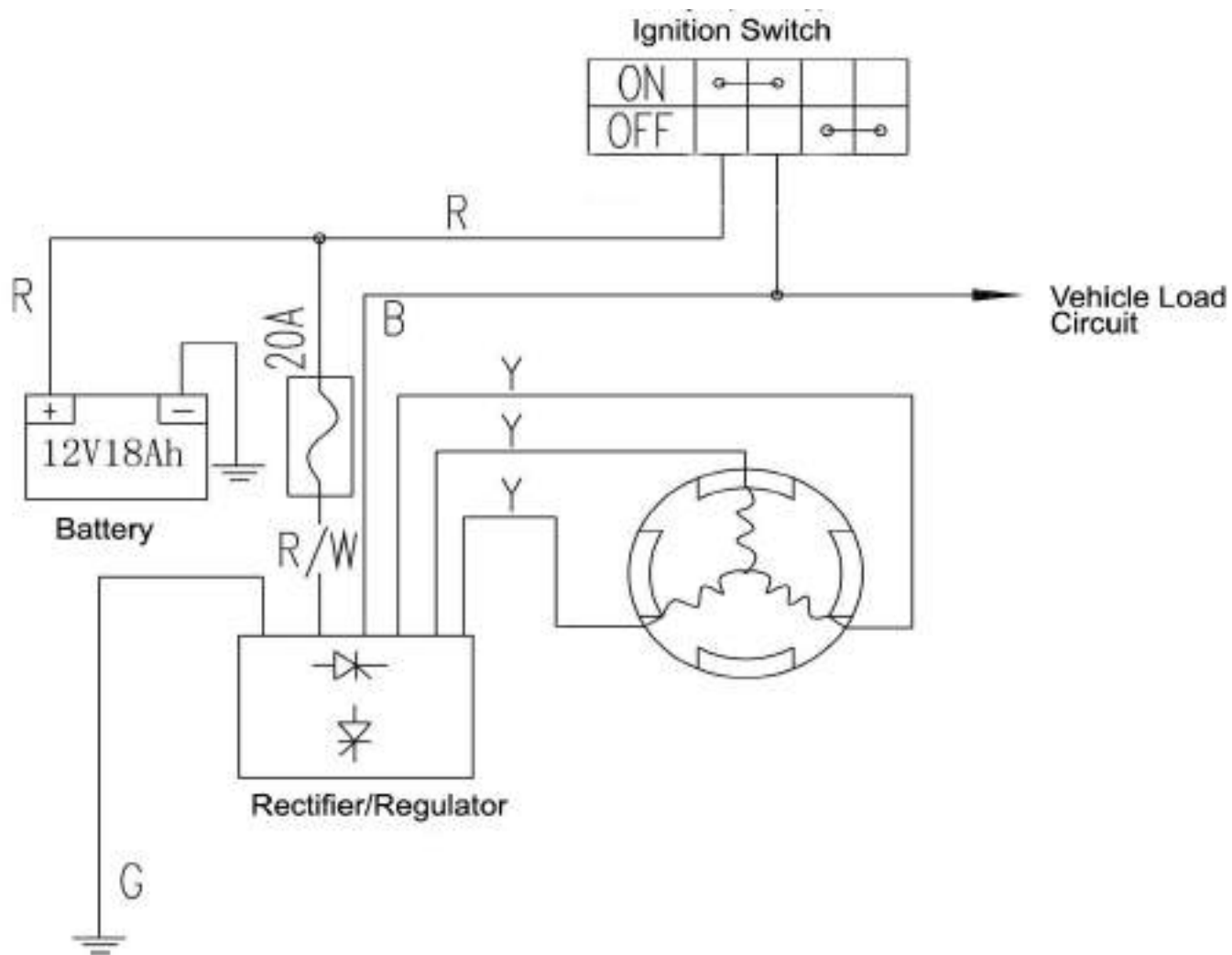

Overhaul information

Note

- ◆ Usually no hydrogen will be generated during charging except when overcharged. Keep away from fires when charging.
- ◆ Electrolyte is highly corrosive, splash to clothes, skin or eyes will cause burn or loss of sight. Wash with plenty of water if splashed. In case of splash into eyes, wash with plenty of water and consult the doctor. The electrolyte on the clothes may contact the skin as well, it will cause damage to the clothes if stained for a long time. Change a clothes and wash away the electrolyte.

Note

- ◆ Spark arc may be generated when removing or joining the electrical parts with switch on and will damage the electrical parts such as rectifier. Operation should be done with ignition switch OFF.
- ◆ Remove battery from vehicle for charging and do not open the electrolyte cover.

Note

Replace if the battery service life expired.

- Keep the ignition switch OFF when removing electrical parts.
- Disconnect the negative connection of battery if it is stored on the vehicle
- Fast charging is not recommended as it may reduce the battery life.
- If battery is repeatedly charged and discharged fully (fully-charged and fully-discharged), it may cause damage to the battery or shorten the service life or lower the capacity of battery. In addition, the capacity of battery will also lower in 2~3 years even under normal use. So the battery should also be replaced.
- If the open voltage is less than 12.4V, charge the battery normally to raise the open voltage up to 12.4V.
- Refer to troubleshooting table (→8-3) for inspection of charging system
- Refer to Engine Maintenance for removal and installation of AC magneto
- Inspection of battery should be done following the owner's manual of battery tester.

Overhaul standard

Item		Standard	
AC magneto	Model	Permanent magnet alternator	
	Output	3-phase AC	
	Resistance of charging coil (20°C)	0.2-0.3Ω	
Rectifier Type		3-phase loop rectification, controllable parallel connection, regulated voltage	
Battery	Capacity	12V10Ah	
	Current Leakage	Less than 1mA	
	Voltage between terminals	Fully-charged	12.8V
		Insufficient charge	Less than 11.8V
	Charging current/time	Standard	0.9A/5~10hours
Fast charge		4A/60minutes	

Troubleshooting

Battery overflow

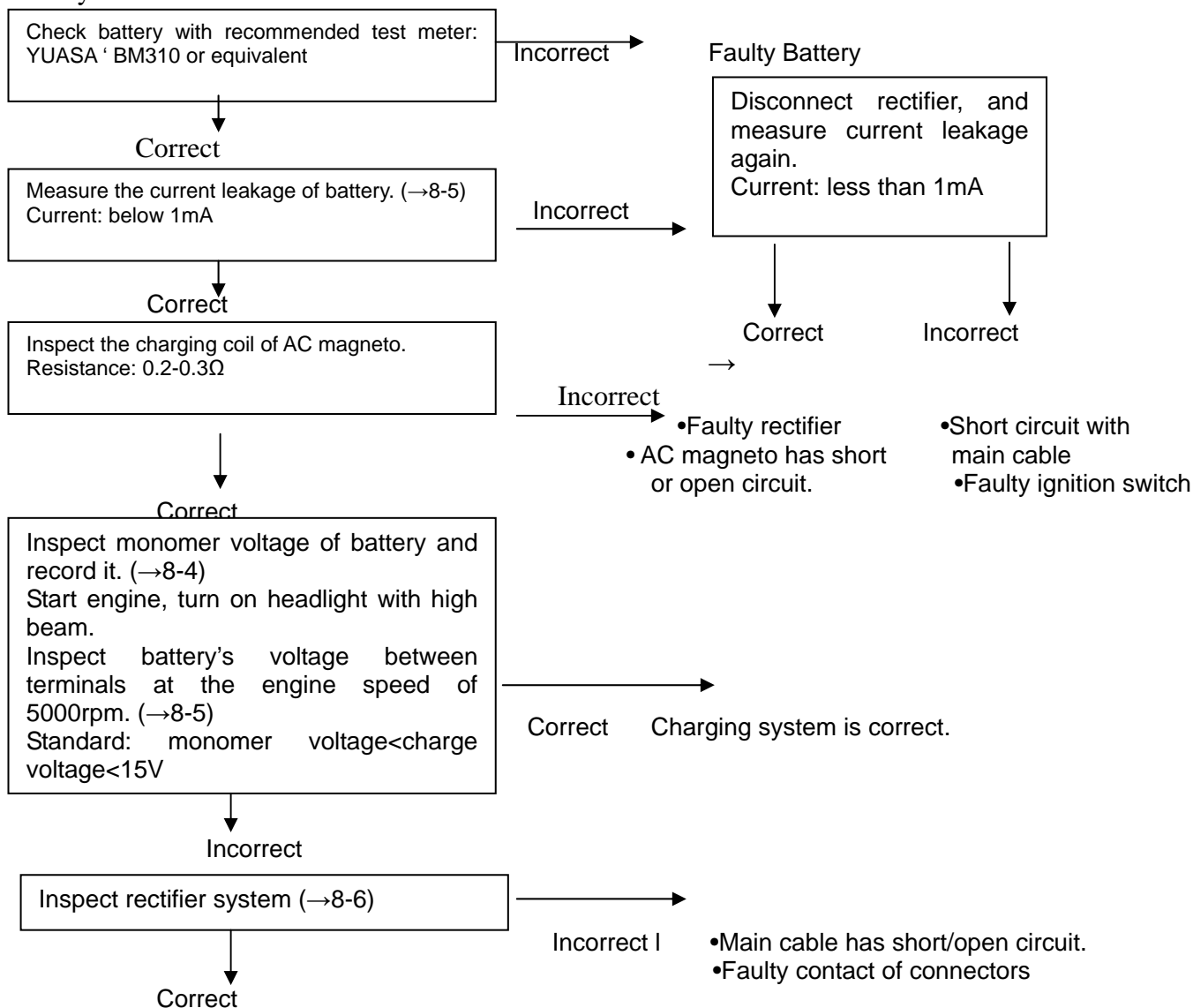

Battery

Note:

Keep the ignition switch at OFF before operation.

Remove:

- Seat (→2-3)
- Bolt1&Bolt2
- Battery fixing plate
- Battery cover

Loosen negative pole screw and disconnect negative lead.

Remove positive pole cap and screw.

Disconnect positive lead.

Installation:

Reverse the removal procedure for installation.

Note:

- Apply clean lubricant grease to the pole after installation.
- Install cap firmly on the positive pole after installation.

Inspection:

Measure voltage between battery terminals, and check test status.

Complete test: 12.8V

Insufficient test: <11.8V

Insufficient charge: → Recharge

Note:

When recharging after normal charging, measure the voltage between terminals after 30 minutes. Measuring immediately after recharging will not gain the correct test due to the sharp voltage changes between the terminals.

Battery

Note:

Usually no hydrogen will be generated during charging except when overcharged. Keep away from fires when charging.

Charge according to the current and time specified on the label of battery.

Remove battery from vehicle. (Refer to above content)

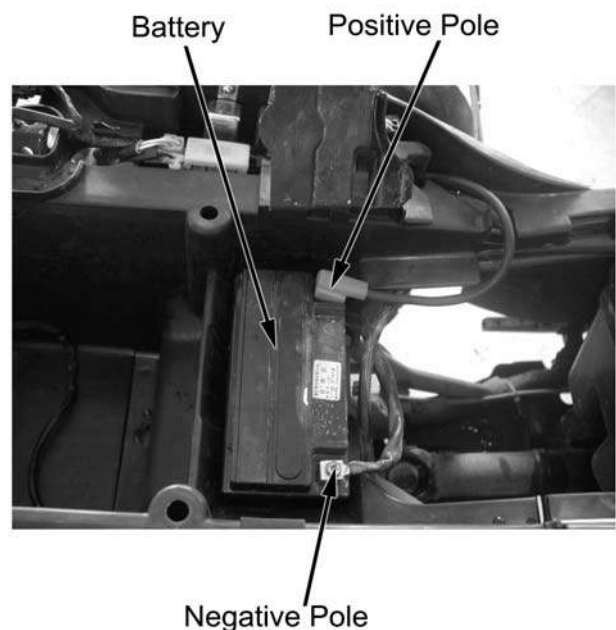
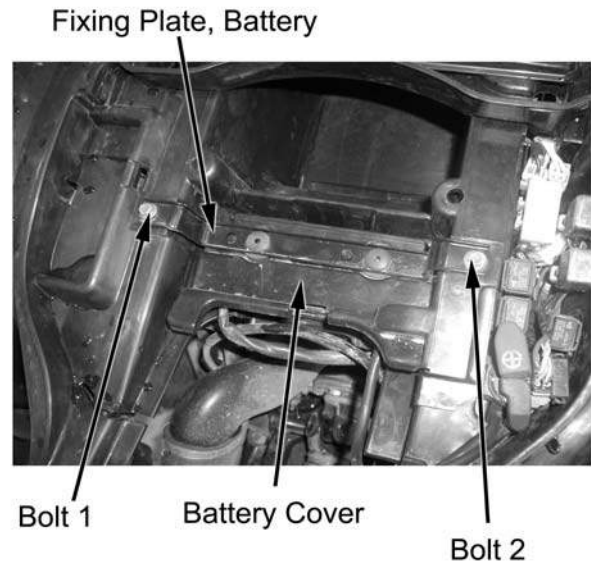

Connect charger's positive wire to battery's positive pole.

Connect charger's negative wire to battery's negative pole.

**Charging current/time: Standard: 0.9A/5~10hours
Fast charge: 4.0A/60mins**

Note:

- Keep the electrolyte temperature under 45 °C . Reduce current to adjust the temperature if it is too high.
- Fast charge will reduce battery's life or cause damage to battery. Do not use fast charge unless in emergency case.

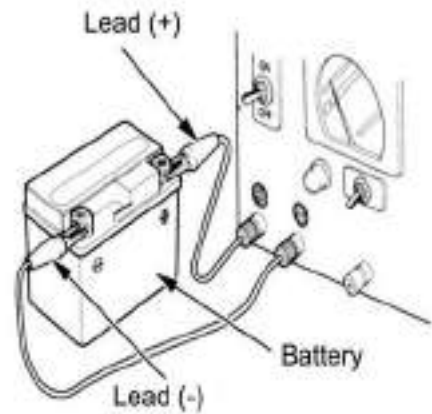

Inspection of Charging System

Inspect charging status

- Remove battery (→15-4) and install a fully charged battery.
- Keep ignition switch at "OFF" position.
- Connect voltmeter between battery's terminals after engine is started and warmed up.

Note:

- **Avoid short circuit when measuring**
- **Overvoltage may be generated when removing or joining the battery terminals with switch ON and will damage the multimeter and the electrical parts. Operation should be done with ignition switch OFF.**
- **Use a fully charged battery for inspection.**



Start engine and turn on high beam.

Increase engine speed slowly. Check voltage between battery terminals.

Voltage between terminals at engine speed of (5000r/min): 13.5-15V

Standard:

Battery's monomer voltage<charging voltage<15V (5000rpm)

Electric Leakage Test

Remove seat (→2-3)

Remove battery fixing plate (→2-3)

Open battery cover

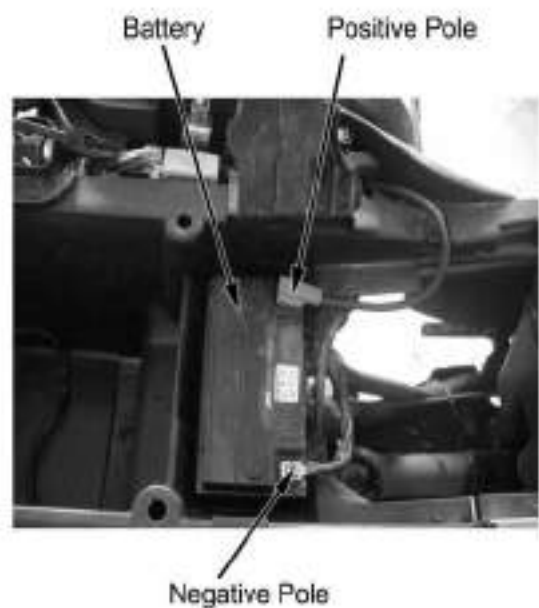

Keep ignition switch at the "OFF" position, and remove negative wire from battery.

Remove fuse box from inside of rear fender.



Connect amperemeter between battery negative pole and negative lead

Measure current leakage with ignition switch at the "OFF" position.

Note:

- If the measured current is higher than the maximum limit, the multimeter will be burnt. Therefore, measure the current by shifting from the high to the low range.
- Do not turn on the ignition switch when measuring the current.

Current Leakage: less than 1mA

When current leakage is higher than specified limit, there is fault with the return circuit.

Disconnect terminals and connectors while measuring current to check out the faults.

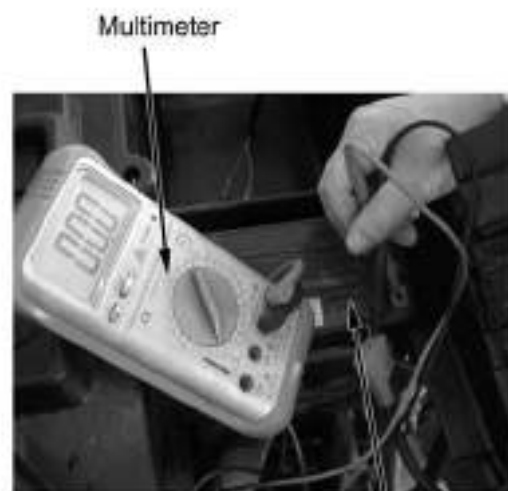

Rectifier/Regulator System inspection

Note:

Inspection can be done without removing the AC magneto from engine.

Remove:

- Seat (→2-3)
- Right & left side panels (→2-6)
- Rear top cover(→2-5)
- Battery cover and battery(→8-4)
- Rear fender(→2-10)

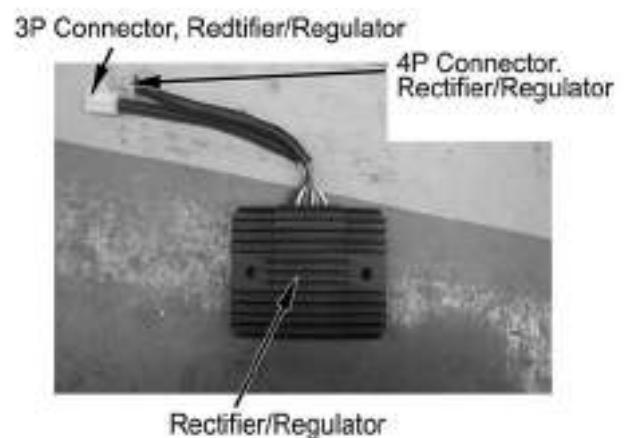

Disconnect the 2 connectors of rectifier/Regulator

Check the connector terminals for loosening, bending, rust or come-off.

Check the following items of the main cable terminals of the two rectifier connectors:

Item	Result
Battery wire (red)	There should be voltage between red terminal (+) and frame body earth wire
Earth wire (green)	Green terminal must be connected with frame body earth wire
Charging coil (yellow, yellow, yellow)	Resistance between yellow terminals is: 0.2-0.3Ω (at 20°C)
Ignition switch lead wire (black)	Black lead wire must be connected with black terminal.

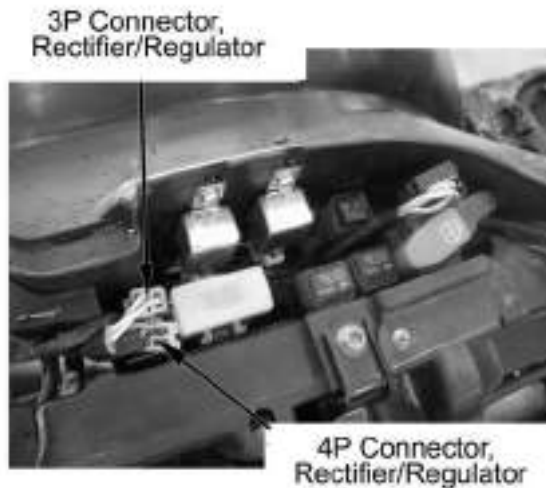

Installation:

Reverse the removal procedure for installation.

Note:

Wires, hoses and cables should be routed properly.
(→Chapter1)

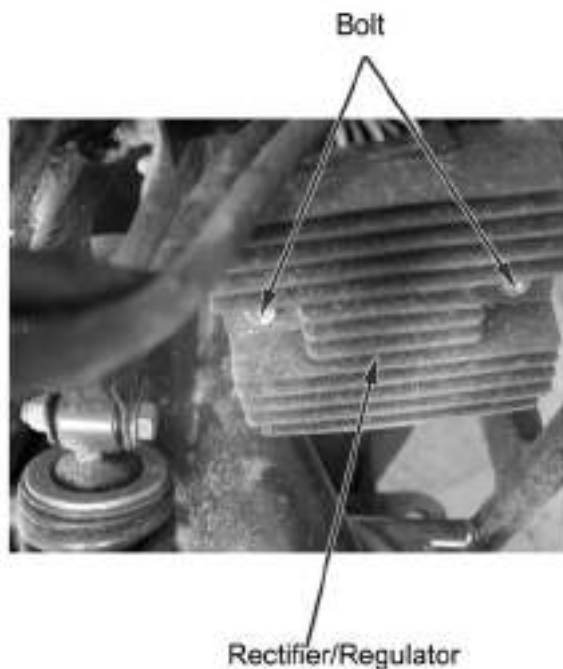

Inspection of AC magneto

Remove left side panel (→2-6)

Disconnect connectors of AC magneto (yellow, yellow, yellow) and pickup coil (black/white/green).

Measure the resistance between the yellow terminals of the AC magneto 3P connector.

Resistance: 0.2-0.3Ω (at 20°C)

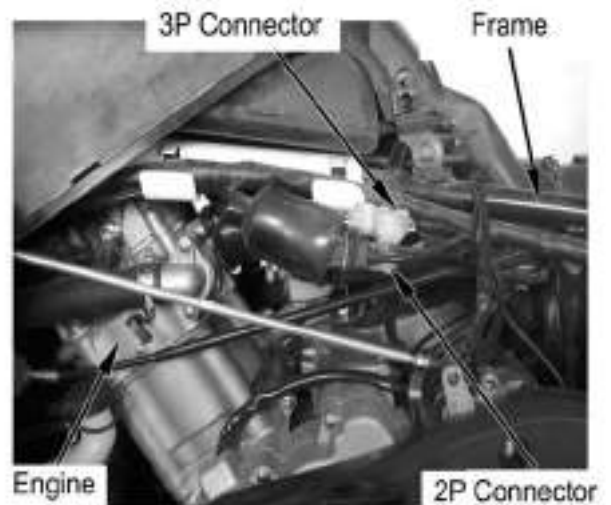

Make sure the yellow terminal of AC magneto 3P connector is not connected with frame body earth wire.



Replace with a new AC magneto in case of any faults found in above check. (→Engine maintenance manual)

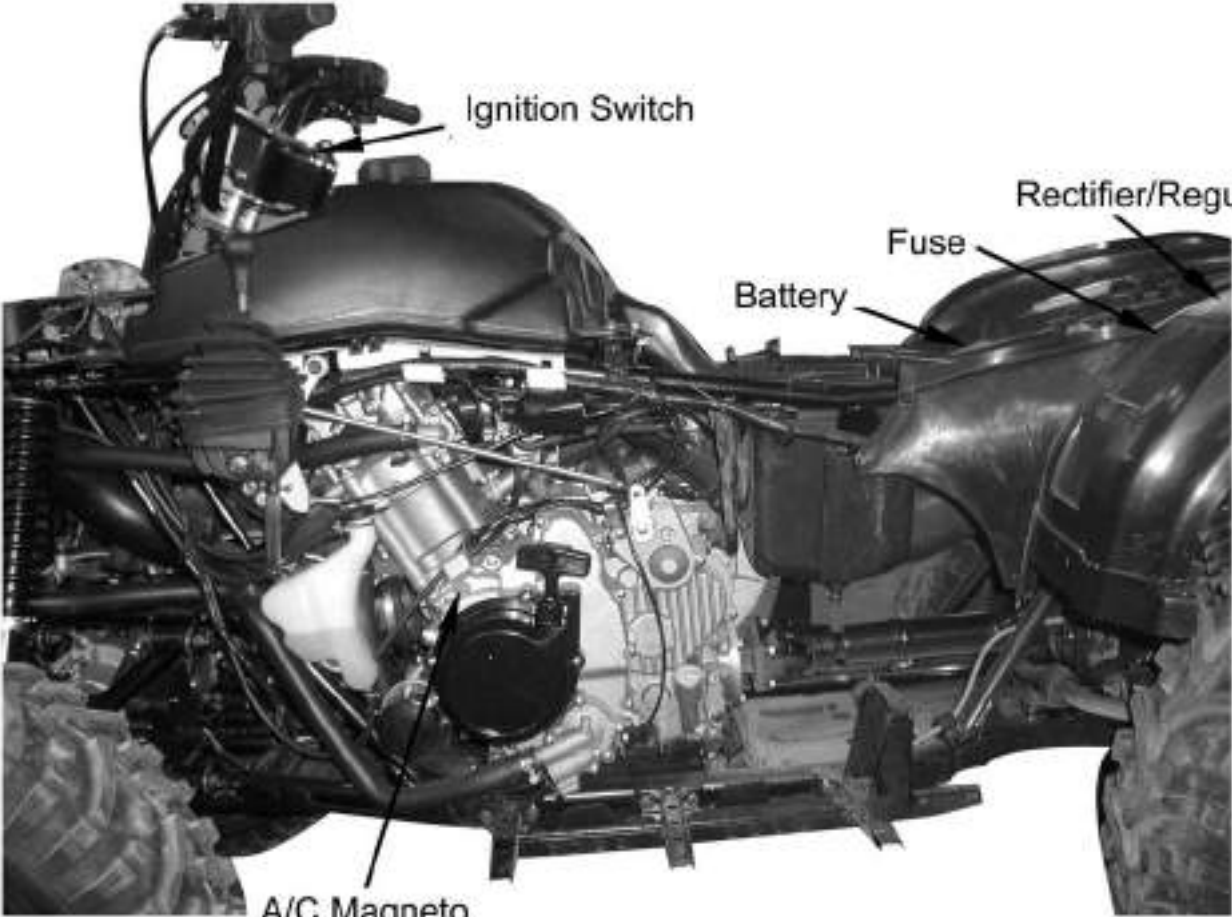

Overhaul Info.....	9-1	Pickup Coil	9-6
Troubleshooting.....	9-3	Ignition Coil	9-6
Inspection of Ignition System.....	9-4	Ignition System Diagram	9-7

Overhaul information

Note:

Exhaust gas contains toxicant, DO NOT keep the engine run for a long time in a closed or poorly ventilated place.

- ◆ Inspect ignition system in the order of the content in troubleshooting table
- ◆ Refer to (9-7) for ignition system diagram
- ◆ Ignition advancer is integrated in the CDI, so the ignition system will automatically adjust ignition time.
- ◆ Be careful with CDI overhaul. Dropping or strong impact may cause damage to CDI. In addition, overvoltage may be generated on CDI and cause damage to return circuit when removing or joining the connectors and terminals with switch ON .Always shut the ignition switch when overhauling.
- ◆ Most of the failures of ignition system are caused by faulty contacts between connectors and terminals. Check all the connections for any faults before overhauling.
- ◆ Select spark plug of proper heat value. Improper spark plug may cause malfunction or damage of engine.
- ◆ Refer to Chapter 10 for inspection of switches

Overhaul standard

Item		Standard
Ignition		CDI, battery DC digital ignition
Spark Plug	Standard	DPR7EA-9(NGK)
	Optional	DR8EA, D7RTC
	Spark plug gap	0.8-0.9mm
Ignition timing	Maximum advance angle	34° CA
Peak voltage	Ignition coil	>200V
	Impulse generator	4V

Special tool**Peak voltage oscillograph 07HGJ-0020100**

(Use together with digital multimeter available in the market with input resistance over 10MΩ/DCV)

Troubleshooting

- ◆ Engine cannot be started.
- ◆ Check fuel and air channels for any faults; If the fuel and air channels are normal, check the ignition system.
- ◆ Inspect ignition system for the following items:

1. Spark inspection:

Check in the following steps:

Remove spark plug

Remove spark plug cap

Set high tension flexible cable end to earth

Check spark arc

It is normal if spark arc is more than 8mm, while it is weak if it is less than 5 mm.

If the spark is normal, check the spark plug.

A faulty spark plug may be caused by the following reasons:

- (1) Spark plug is too wet and drowned. This is because the gas mixture is too thick. Cut the fuel and start the engine several times..
 - (2) Carbon deposit on spark plug---Mixture too thick or oil combustion in the combustion chamber. Clean and burnish the spark plug.
 - (3) Cracks with spark plug insulator.
 - (4) Spark plug electrodes have short circuit or it is obstructed between negative pole and thread or positive pole and input end.
2. Faulty spark includes: no spark and weak spark.
- Inspect the following aspects if there is no spark.
- (1). Inspect ignition coil with multimeter or measurement in the following steps:
 - 1) Measure primary bobbin resistance, usually it is about 1Ω.
 - 2) Measure secondary bobbin resistance, usually it is about 4.2K.
 - 3) Measure damp resistance, usually it is about 5K.
 - (2). Check CDI if it is out of service.
 - (3). Check ignition circuit. Usually the voltage between black wire and earth wire (green) should be 12V. If there is no voltage, check from the battery positive terminal to the end of black wire.
 - (4). Check the cable: check if there are any faults from the input of trigger signal (output of magneto pickup) to output (CDI terminal) and ignition output wire (black/yellow).
 - (5). Check stop switch. When switch is at the ignition position, black/white wire should be cut with green wire.

In case of weak spark, check the following:

- (1). Check CDI .
- (2). Check ignition coil and secondary coil whether there is short circuit, or fault with the damp resistance.

Inspection of Ignition System

Note:

- If the spark plug generates no spark, check first if there is come-off, loosening or poor contact with the wiring, then measure the peak voltage.
- Different multimeter has different input resistance and shows different readings. Measure with digital multimeter with input impedance over 10MΩ/DCV).

Connect peak voltage oscillograph with digital multimeter.

Special tools

Peak voltage oscillograph 519-922-150000

(Use together with digital multimeter available from the market with input impedance over 10MΩ/DCV)

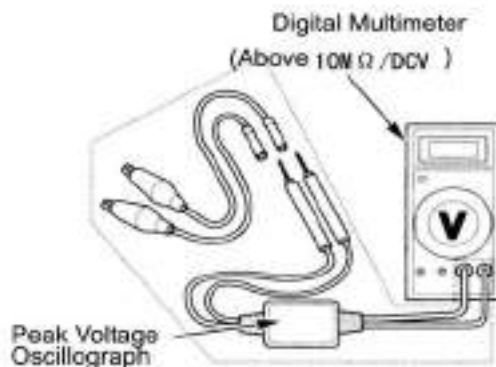

Ignition Coil Primary Voltage

Note:

- Measure after all the wires are correctly connected.
- Inspection should be done when the spark plug and spark plug cap are properly installed. If the spark plug is removed, the peak voltage will rise.

Remove left side panel. (→2-6)

Keep spark plug in the cylinder head, install qualified spark plug on the spark plug cap and earth the engine. Open rubber cover of ignition coil, keep the ignition wire connected, and connect peak voltage oscillograph between primary wire terminal and frame body earth wire.



Special tool

Peak voltage oscillograph

(Use together with digital multimeter available from the market with input impedance over 10MΩ/DCV)
Connecting terminals: black/yellow (+) –frame earth wire (-)

Turn ignition switch to the ON position, and start engine.

Peak voltage: above 150V

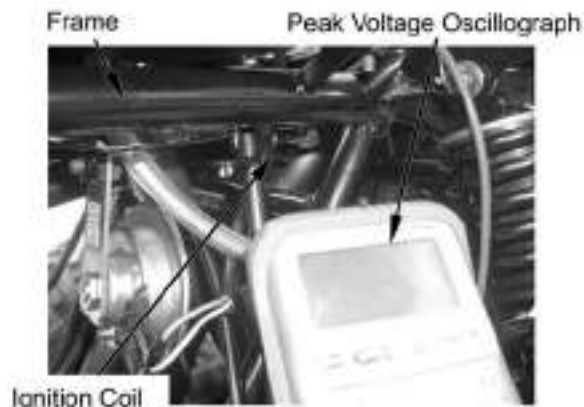

Pickup Coil**Note:**

- Measure after all the wires are correctly connected.
- Inspect with compression pressure in the cylinder, spark plug and spark plug cap are properly installed. If the spark plug is removed and then do the measurement, the peak voltage will rise.

Remove left side panel (→2-3)

Disconnect CDI unit connector.

Connect peak voltage oscillograph terminal with the following terminal of main cable.

Special tools**Peak voltage oscillograph 07HGJ-0020100**

(Use together with digital multimeter available from the market with input impedance over 10MΩ/DCV)

Connecting terminal: blue/yellow (+) –green (-)

Turn ignition switch to the ON position, and start engine.

Peak voltage: over 0.8V

Note:

When measuring the voltage, do not touch the terminal with finger to avoid electric shock.

If peak voltage obtained from CDI unit connector is improper, measure again the peak voltage on the AC magneto 2P connector.



Pickup

Remove:

- AC magneto connector
- Water pump inlet hose and outlet hose, and drain coolant. (→Chapter 4)
- Crankcase breather hose. (→Engine Service)
- Muffler. (→Chapter 2)
- Engine right side cover. (→Engine Service)

Note:

Stator is installed on the right side cover and is attached by the magnet of rotor. Be careful not to hurt the fingers when removing.

Disconnect primary terminal of ignition coil.
Loosen bolt, remove AC magneto stator and pickup.

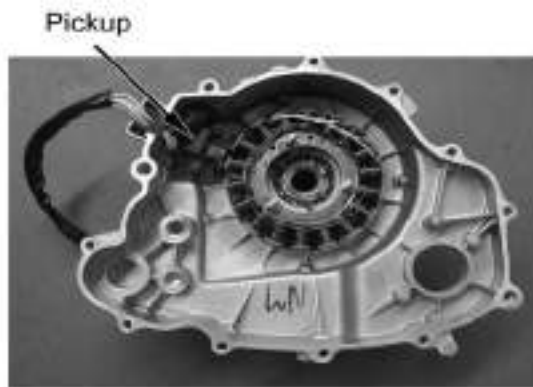

Installation

Reverse the removal procedure for installation.

Ignition Coil

Remove left side panel (→2-6)
Remove spark plug cap from spark plug (→Engine Service)

Loosen bolt, and remove ignition coil.

Installation

Reverse the removal procedure for installation.

Note:

Wires, cables and hoses should be routed properly (→Chapter 1).

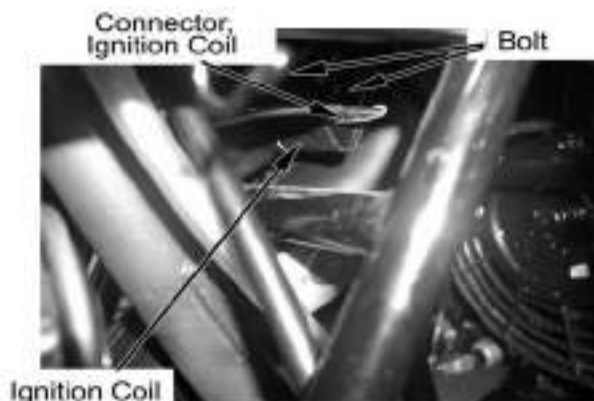
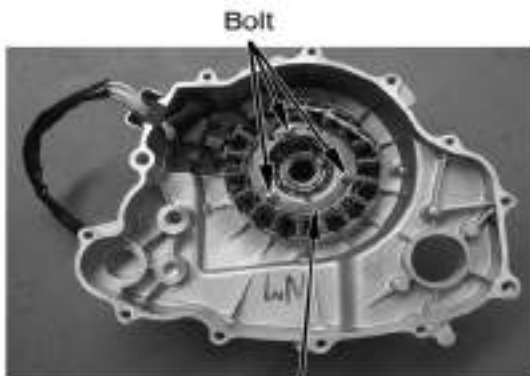
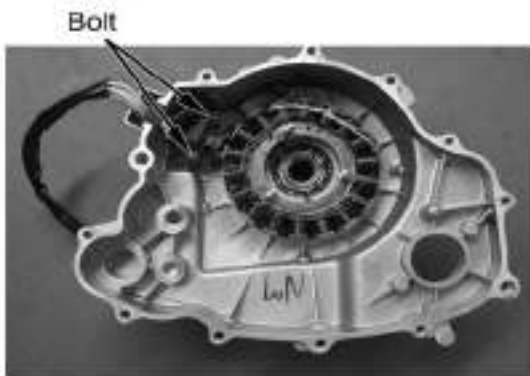

Ignition System Diagram

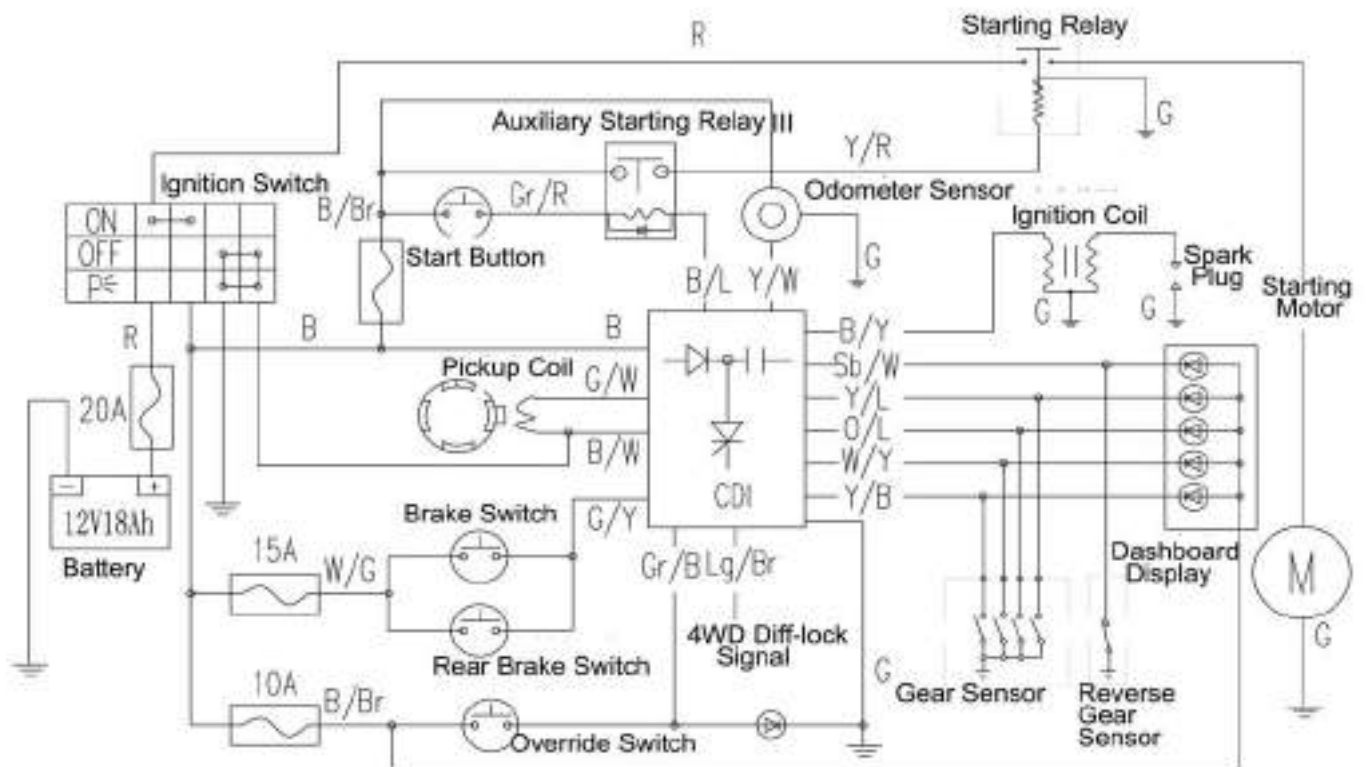
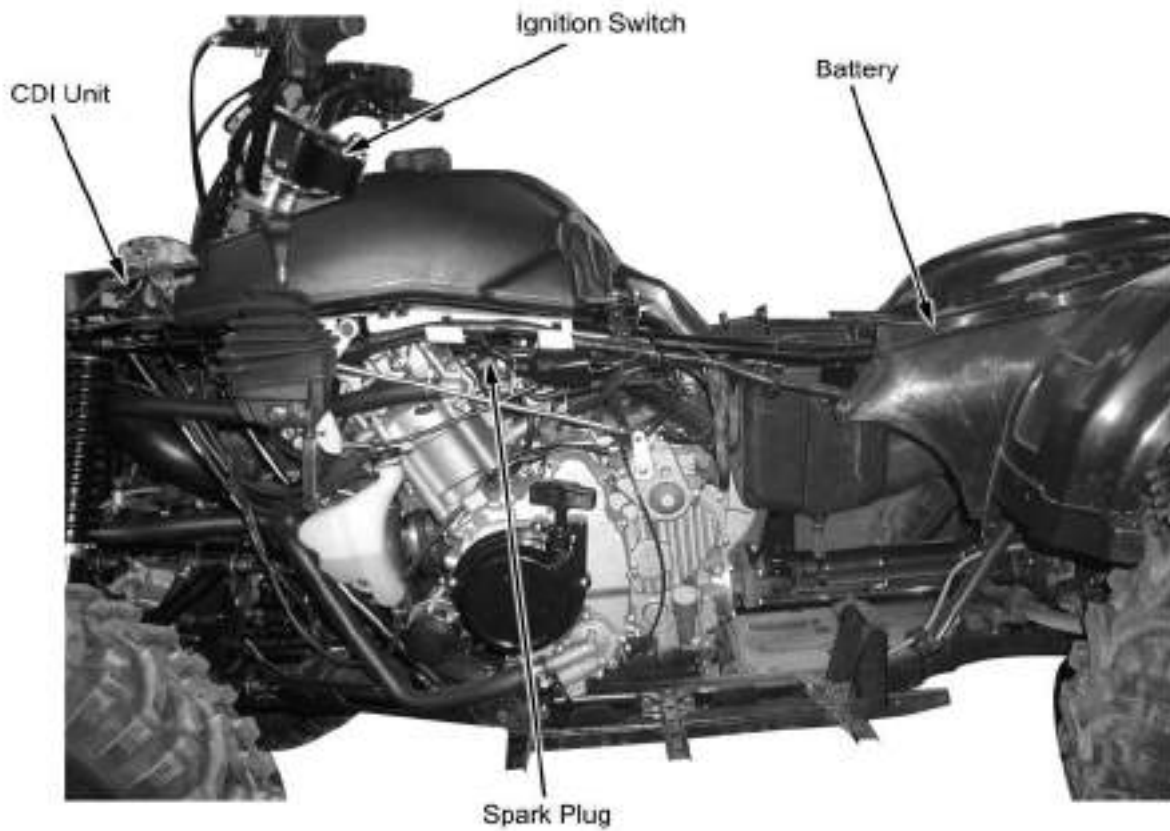

Overhaul Info.....	10-1	Dashboard	10-9
Troubleshooting	10-2	Fuel Sensor	10-10
Replacing bulbs..	10-3	WaterTemperature Transducer..	10-12
Head Light	10-5		
Ignition Switch.....	10-6		
Handlebar Switch	10-7		
Brake Light Switch.....	10-8		
Horn.....	10-8		

Overhaul Information

Warning

- ◆ Headlight bulb will be very hot when it is turned on. Do not touch it after it is just turned off. Operation should be done when the bulb is cooled down.
- ◆ Inspection of water temperature alarm may use fire source and liquid of high temperature. Do not put flammable matters nearby and take care not to get burnt.
- ◆ The temperature of headlight is quite high when turned on. Replacing with bare hand or stained glove will cause oil stains on the glass face which may form hot spot and cause deformation of glass face and damage to bulb.
- ◆ Pay attention to the following when replacing the bulb.
 - Do not replace the bulb when it is turned on. Keep ignition switch in the OFF position, and replace after the bulb is cooled down.
 - Replace the bulb with hands in clean gloves to avoid oil stains on the glass surface.
 - Clean the glass with a clean rag dipped in alcohol or isoamyl acetate in case of any oil stains on the glass surface.
- ◆ If the Inspection has to be done with battery, check if the battery is normal.
- ◆ Inspection of switch continuity can be done without removing the switches from the vehicle.
- ◆ After the inspecting and overhauling of each part, cables and wires should be routed properly (→chapter 1)
- ◆ Refer to Chapter 2 for removal and installation of taillight and rear turning lights

Overhaul Standard

Item		Standard
Fuse	Main	20A
	Sub-fuse	10A 15A×3
Light, bulb	Headlight (Hi/Lo)	12V-35/35W
	Brake light / Tail light	12V-21/5W
	Turning light	12V-10W×4
	Dashboard indicator	12V-1.7W
	Indicators	12V-3.4W

Troubleshooting

Head Light Cannot Turn On

- Broken fuse
- Open circuit with main cable
- Burnt Bulb
- Faulty Switch

Replacing Bulb

Headlight Bulb

Warning

Headlight bulb will be very hot when it is turned on. Do not touch it after it is just turned off. Operation should be done when the bulb is cooled down.

Remove headlight. (→10-5)

Disconnect headlight

Remove dust-proof cap, headlight connector, circlip and replace with a new bulb.

Warning:

- Wear clean gloves when replacing bulb.
- Oil stains on the glass surface may cause break of bulb. Clean the stained surface with alcohol or isoamyl acetate.
- Make sure that the three pins of the bulb should be in line with the three positioning holes in the socket when replacing the bulb.

Bulb specification: 12V-35/35W

Reverse the removal procedure for installation.

After replacing the bulb, adjust headlight beam. (→3-14)

Inspection of Headlight

Turn the ignition switch to ON position, turn light switch to the illuminating position and check if the headlight is on.

—ON: Normal

—Still off: short circuit of main cable or broken main cable



Connector, Headlight

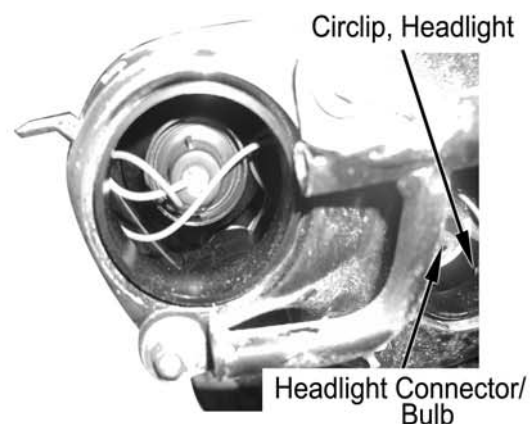

Headlight Connector/
Bulb

Brake Light/Tail Light Bulb

Remove 2 tapping screws,
Remove tail light cover.
Turn brake light/tail light bulb counter clockwise and
remove it.
Replace brake light/tail light bulb

Bulb Specification: 12V-21/5W

Reverse the removal procedure for installation.

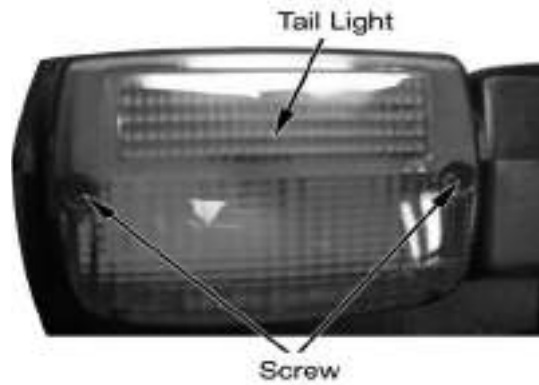

Front Turning Indicator Bulbs

Remove headlight(→10-5)
Remove cover of front turning light
Replace front turning light bulbs

Bulb Specification: 12V-10W

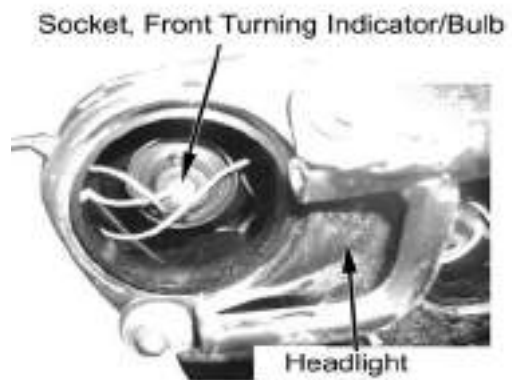

Rear Turning Indicator Bulbs

Remove screw
Remove rear turning indicator cover.
Replace rear turning indicator bulbs.

Bulb Specification: 12V-10W

Reverse the removal procedure for installation.

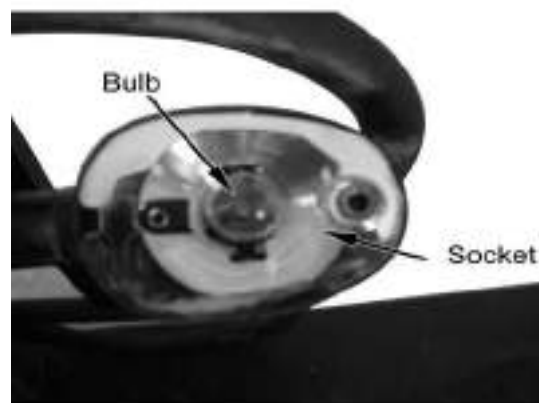
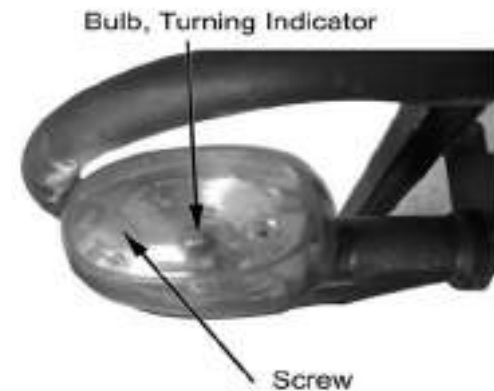

Dashboard Lighter Bulb

Remove dashboard (→10-9)

Remove bulb socket and replace with a new bulb.

Bulb specification: 12V-1.7W

Note:

Main cable and wires should be routed properly (→ chapter 1)

Reverse the removal procedure for installation.

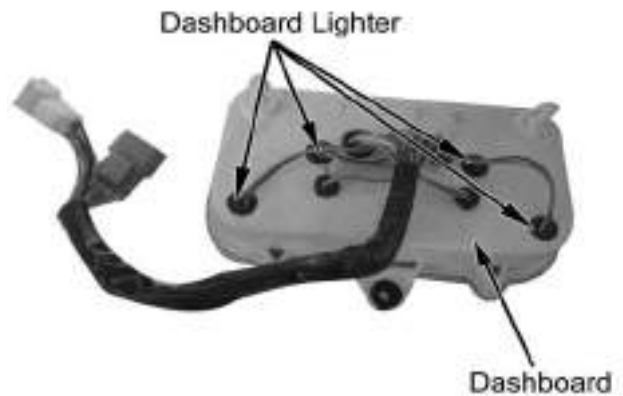

Dashboard Indicator Bulb

Remove dashboard (→10-9)

Remove dashboard indicator socket.

Remove indicating light bulb and replace with new one.

Bulb specification: 12V-3.4W

Reverse the removal procedure for installation.

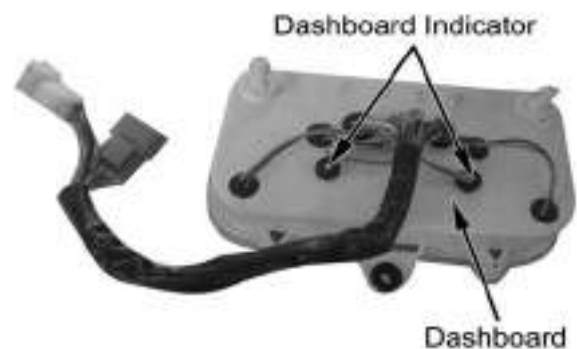

Headlight

Remove:

--Front fender(→2-8)

--3 fixing bolts of headlight cover.

--Headlight cover

--Fixing bolt of headlight, headlight connector

--Headlight.

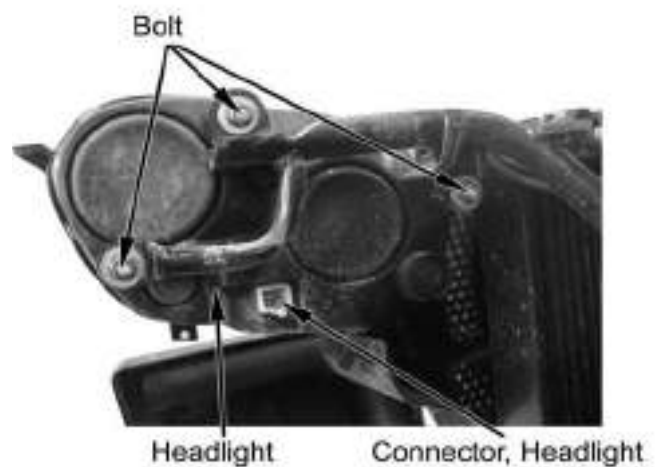

Disconnect headlight connector.

Reverse the removal procedure for installation.

Note:

Be careful not to damage main cable when assembling.



Connector

After replacing, adjust the headlight beam. (→3-14)

Note

Main cables and wires should be routed properly.

Ignition Switch

Inspection

Remove front top cover

Disconnect 4P connector of ignition switch

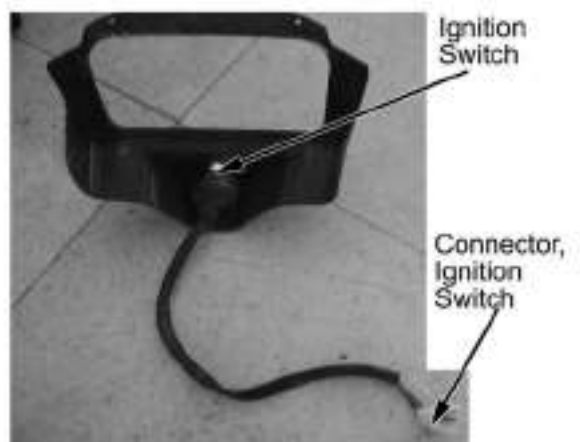

Ignition Switch

Connector, Ignition Switch

Check according to the following table if the connector terminals are in continuity.

● ---- ● means proper continuity

ON	●	●		
OFF			●	●
PE			●	●
	R	B	G	B/W

Remove:

Remove front cover of dashboard (→6-12)
 Remove rear cover of dashboard (→6-14)

Disconnect 4P connector of ignition switch

Remove bolt and ignition switch

Reverse the removal procedure for

Handlebar Switch

Remove front top cover (→2-4)
 Disconnect left and right handlebar switches Check according to the following table the continuity of the terminals.

Lighting Switch

	B/Br	Br	W/L
	●	●	●
	●	●	
●			

Start Switch

OFF		
ON	●	●
	B/Br	Gr/R

Dip Switch

OFF	●	●	
ON	●		●
	W/L	W	L

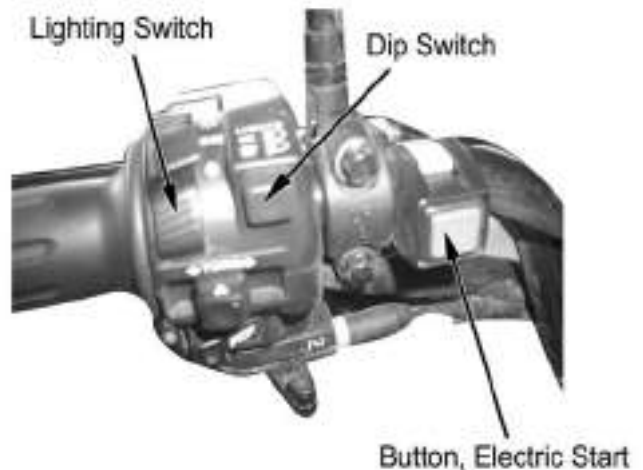
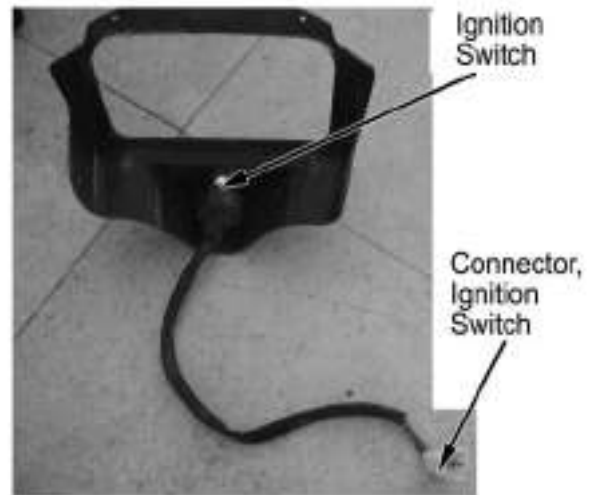

Connector, Handlebar Switch

Turning Light Switch

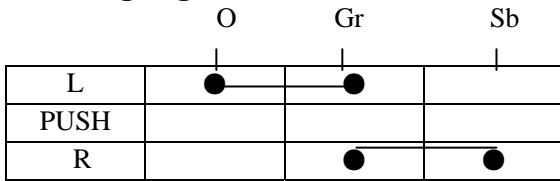

Horn Switch

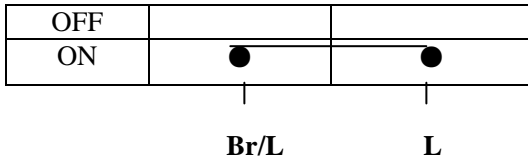

Overriding Switch

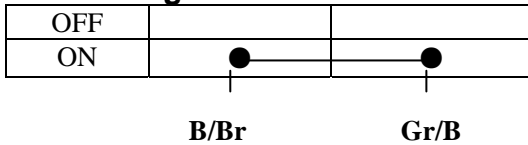

2 WD、4 WD、4WD Diff-Lock Switch

	B r / / R	L / / G	L / / B	B r / / G	G r / / W	L / / G	B r / / R	B r / / G	Lg / / r	G
2WD	●	●			●	●				
4WD			●	●	●	●				
LOC K			●	●			●	●	●	●

Faulty handlebar switch: → Replace (→6-12).

Brake Light Switch

Disconnect brake light switch connector and check terminators for continuity.

Hold the brake lever-----Continuity
Release the brake lever--- No continuity

No continuity: → Replace brake light switch

Horn

Inspection:

Remove front vent grille (→2-15)
Disconnect horn.
Connect with a fully charged 12V battery and check if the horn sounds.

Faulty Horn: → Replace

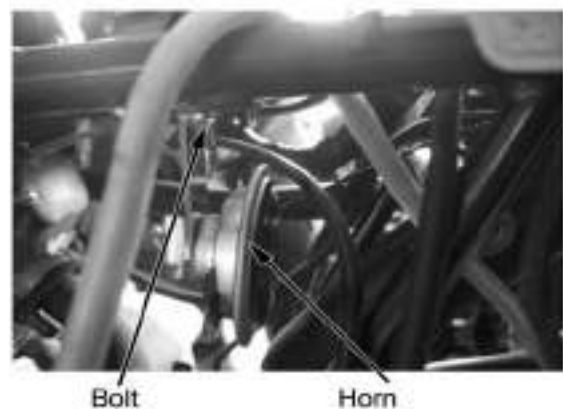
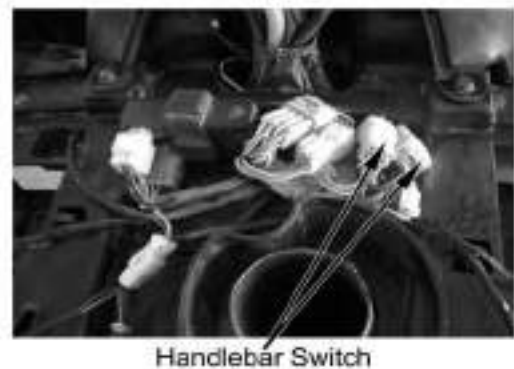
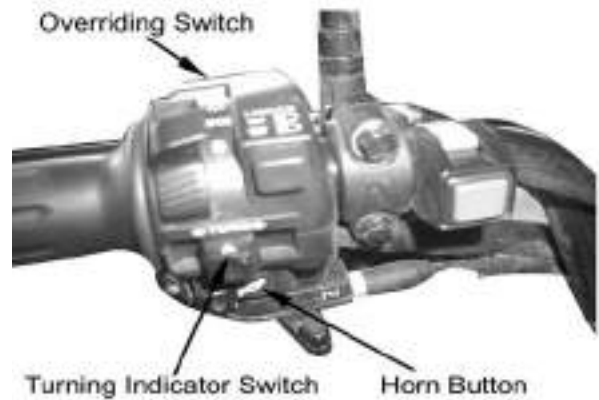

Removal and Installation

Remove horn plug.

Remove fixing bolt and horn.

Reverse the removal procedure for installation.

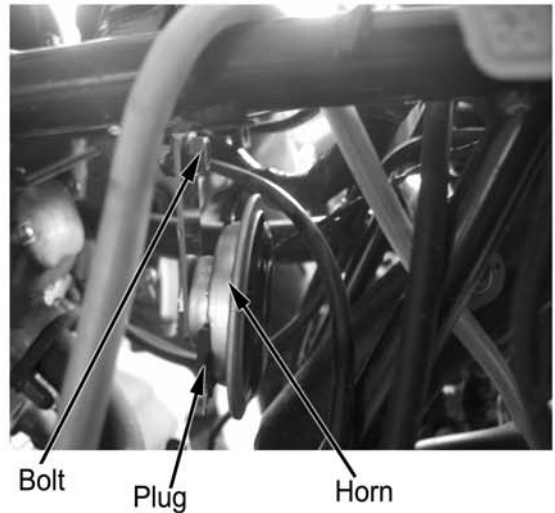

Dashboard

Run the vehicle at low speed and check if the speed indicator moves.

Faulty speedometer: →Replace

Removal and Installation

Remove front top cover (→2-4)

Remove front cover of dashboard (→3-12)

Disconnect dashboard wire connector.

Remove fixing nut and remove dashboard in the direction as illustrated on the right

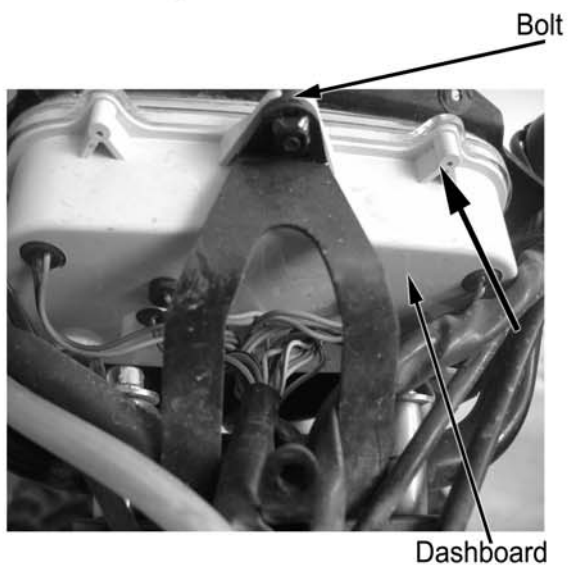

Reverse the removal procedure for installation.

Note:

Main cables and wires shall be routed properly.

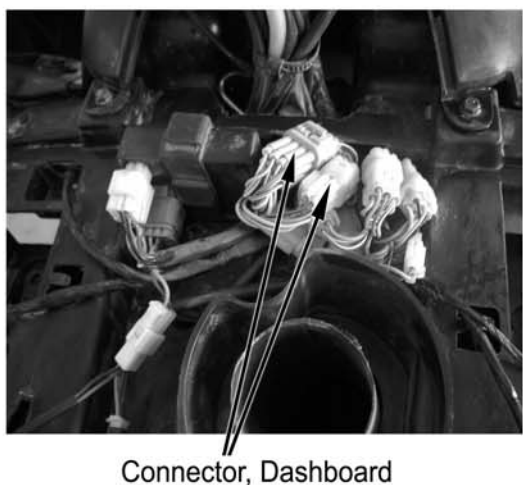

Fuel Sensor

Remove:

--Fuel tank top cover (→2-8)

--4 fixing bolts

--Fuel sensor

Disconnect 2P connector

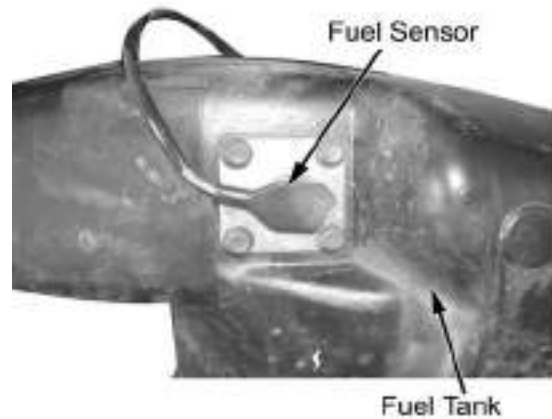

Inspection

Remove fuel sensor (refer to above steps)

Connect 2P connector

Turn ignition switch to ON

Shake fuel sensor float with hand, locate the float position and check if it conforms to the fuel gauge reading.

Non-conformity: →check main cable for damage or short circuit
→Check fuel sensor and fuel gauge



Remove fuel sensor 2P connector.

Connect multimeter between 3P connector terminals.

Shake float with hand and measure the resistance of float at different positions.

Connection Terminal:

Upper: Blue/White-Green: 4-10 Ω (20°C)

Lower: Blue /White-Green: 90-100 Ω (20°C)

Faulty fuel sensor:→ Replace

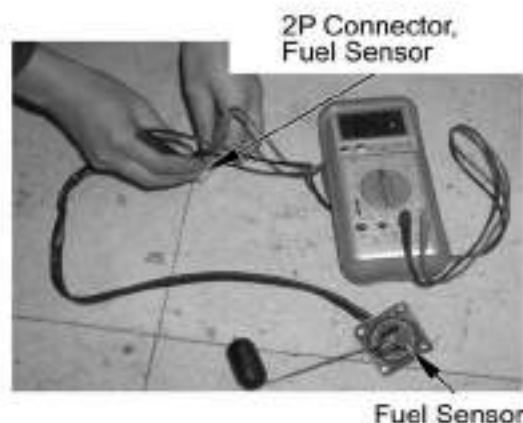

Installation

Put fuel sensor into installation hole of fuel tank.

Fuel sensor should be fitted properly.
No fuel leakage is allowed.

Connect 2P connector

Inspection of Fuel Gauge

Switch on power supply and check if fuel level gauge functions normally.

If fuel gauge works normally,
Reverse the removal procedure for installation of plastic parts and seat.



Connector, Fuel Sensor

Water Temperature Transducer**Warning:**

Be careful not to get scalded and do not place flammables nearby.

Warning

- Coolant must reach the switch thread, and the depth from vessel bottom to sensor top should be over 40mm.
- Keep liquid temperature for three minutes before measuring, and do not raise temperature sharply.
- The thermometer should not contact the vessel bottom.



Water Temperature Transducer

Disassembly:

Remove right side panel (→2-7)

Disconnect and remove transducer.

Put the transducer into a vessel with coolant, slowly heat up the liquid and measure the transducer resistance.

Temperature	Resistance
50°C	154 ± 16 Ω
88°C	52 ± 4 Ω
100°C	27 ± 4 Ω
120°C	16 ± 4 Ω

Transducer out of range: →Replace

Install transducer

Connect water temperature transducer connector.

Fill coolant and discharge air

Reverse the removal procedure for installation of plastic parts and seat.

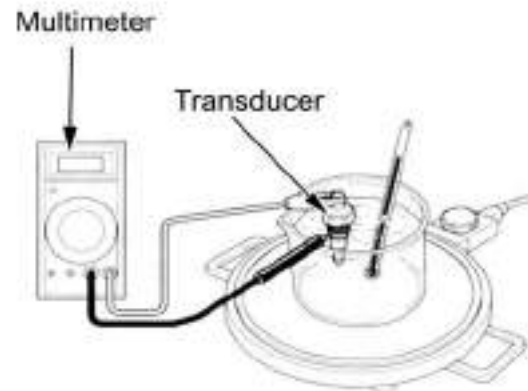

Please reference to PDF document :

LINK: [CF500 & CF500A Circuit Diagram, Wiring Diagram.PDF](#)

Operation Notice.....12-1
 Starting Failure/Hard Starting.....12-1
 Unstable Engine Running or Engine Stops.....12-2
 Poor Engine Performance in High-speed Range or Slow Speed Rising.....12-3
 Unstable Idle Speed.....12-4
 Poor Engine Performance in Middle or High Range.....12-5

Operating Notice

This chapter is a general explanation of major troubleshooting of the whole engine. Refer to the relevant chapters for troubleshooting not listed in this chapter.

Starting Failure/Hard Starting

In case of starting failure or hard starting, refer to chapter of starting system (Engine maintenance notebook) for troubleshooting and check the starting system whether have problems or not.

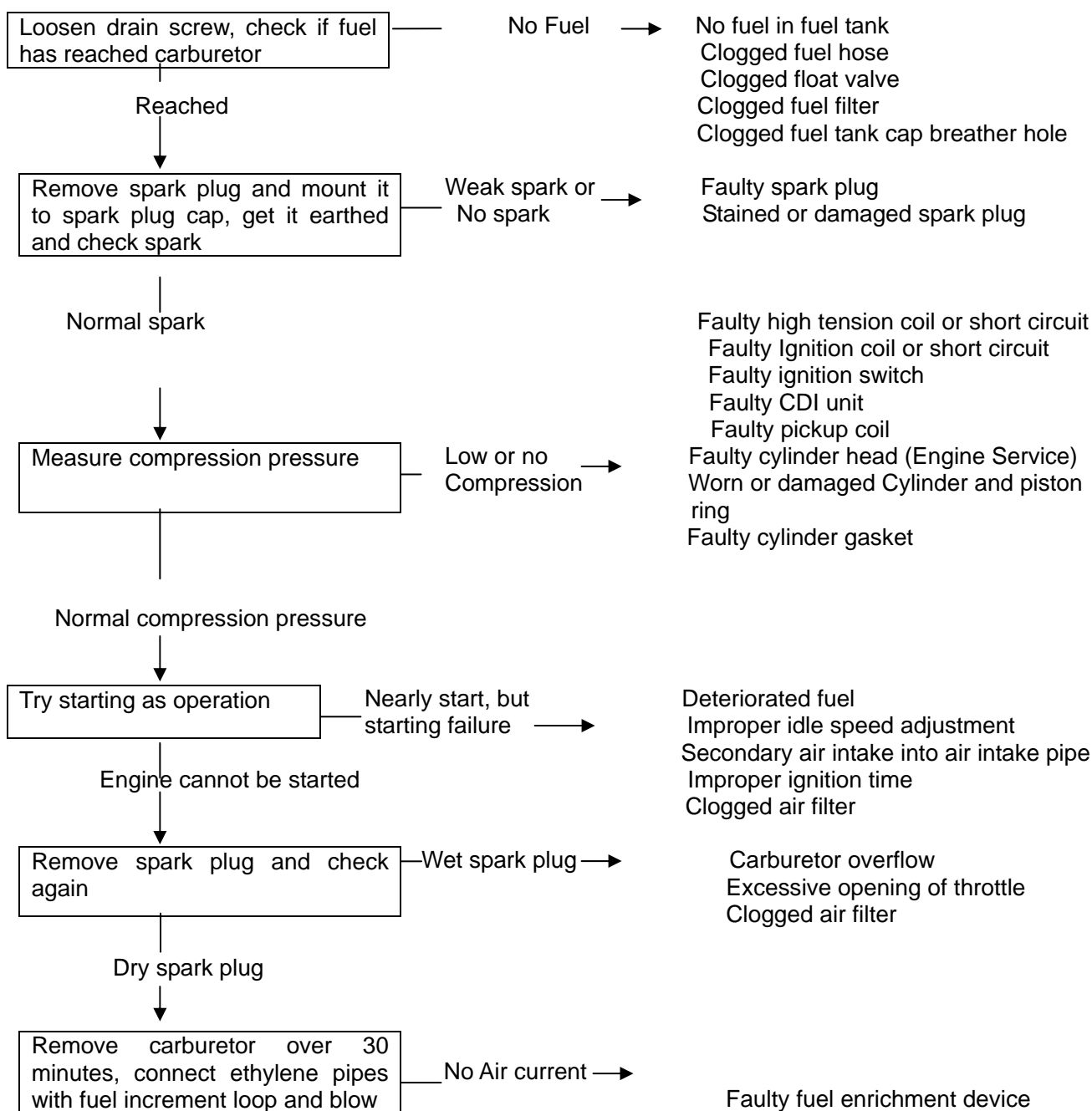

Unstable Engine Running or Engine Stops

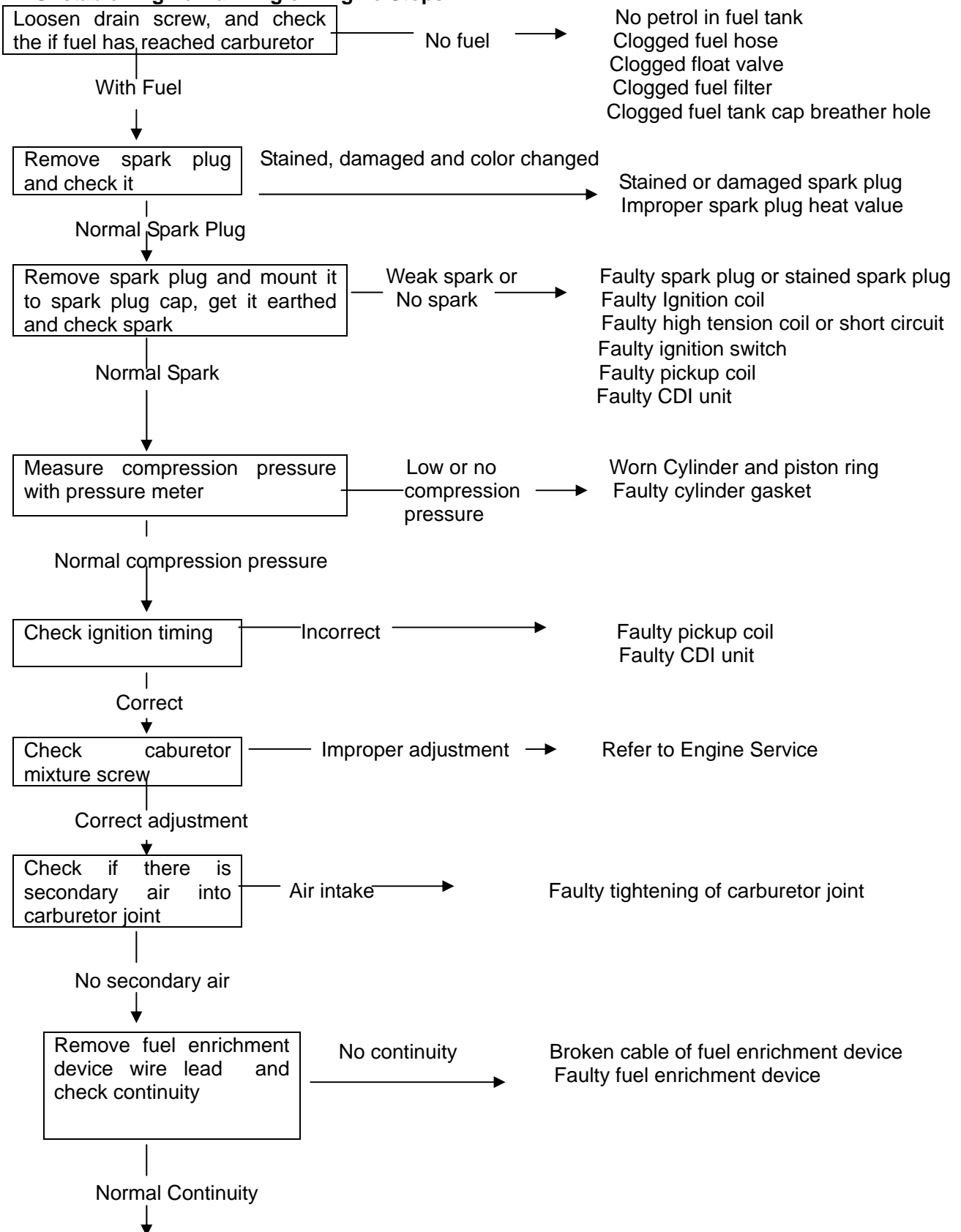

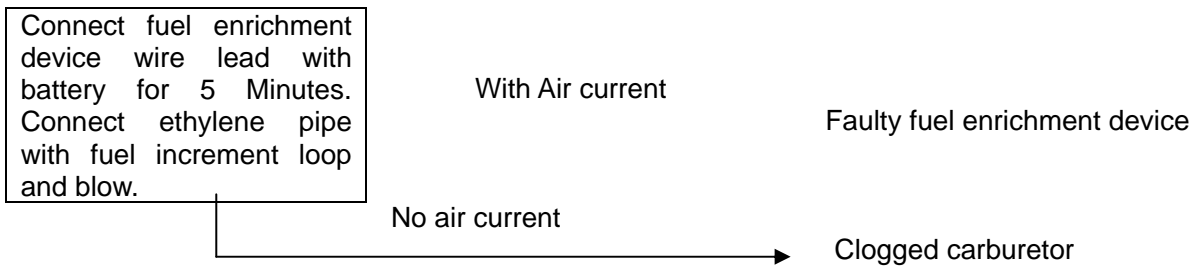

Poor Engine Performance in Hi-speed Range or Slow Speed Rising

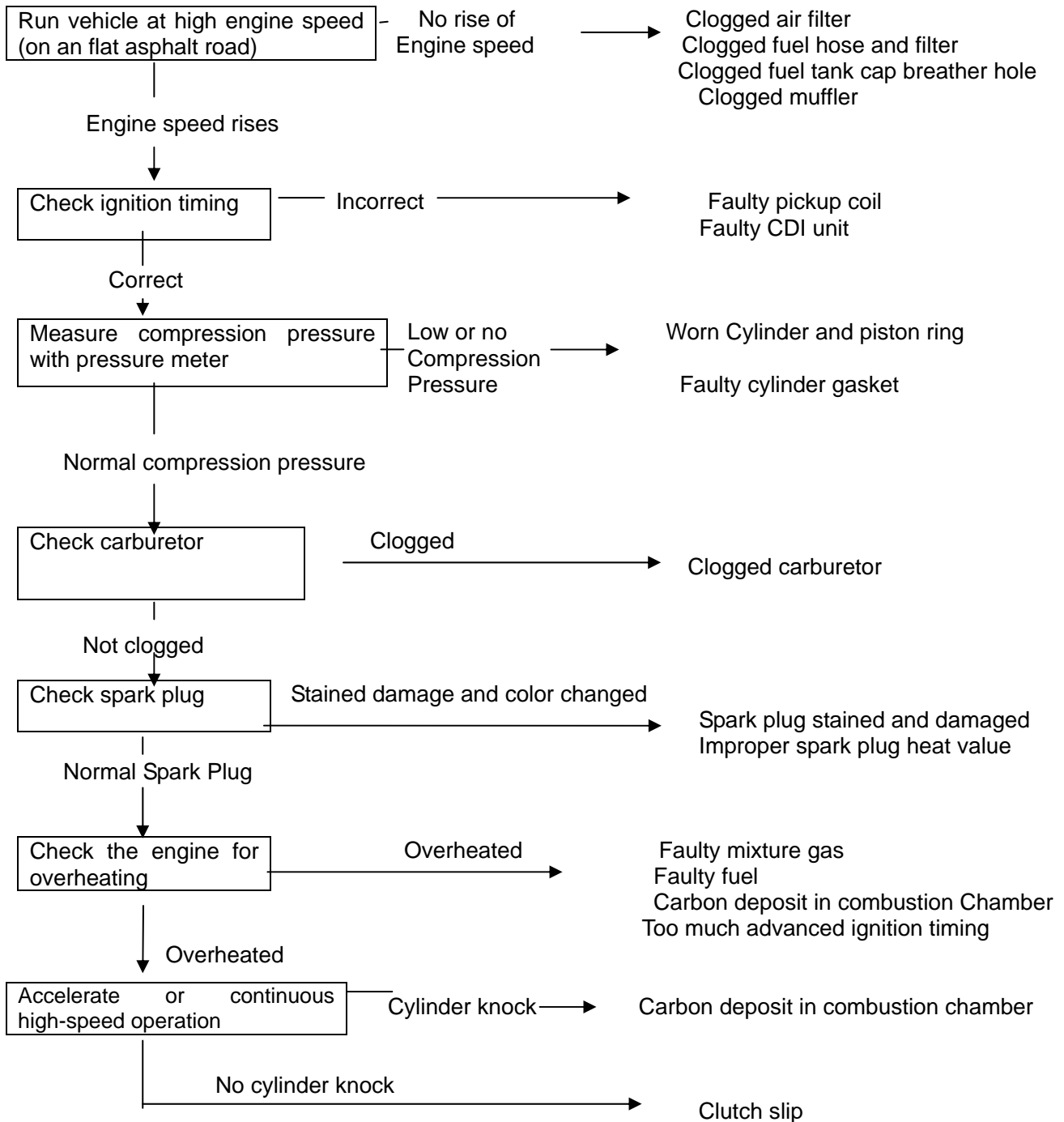

Unstable Idle Speed

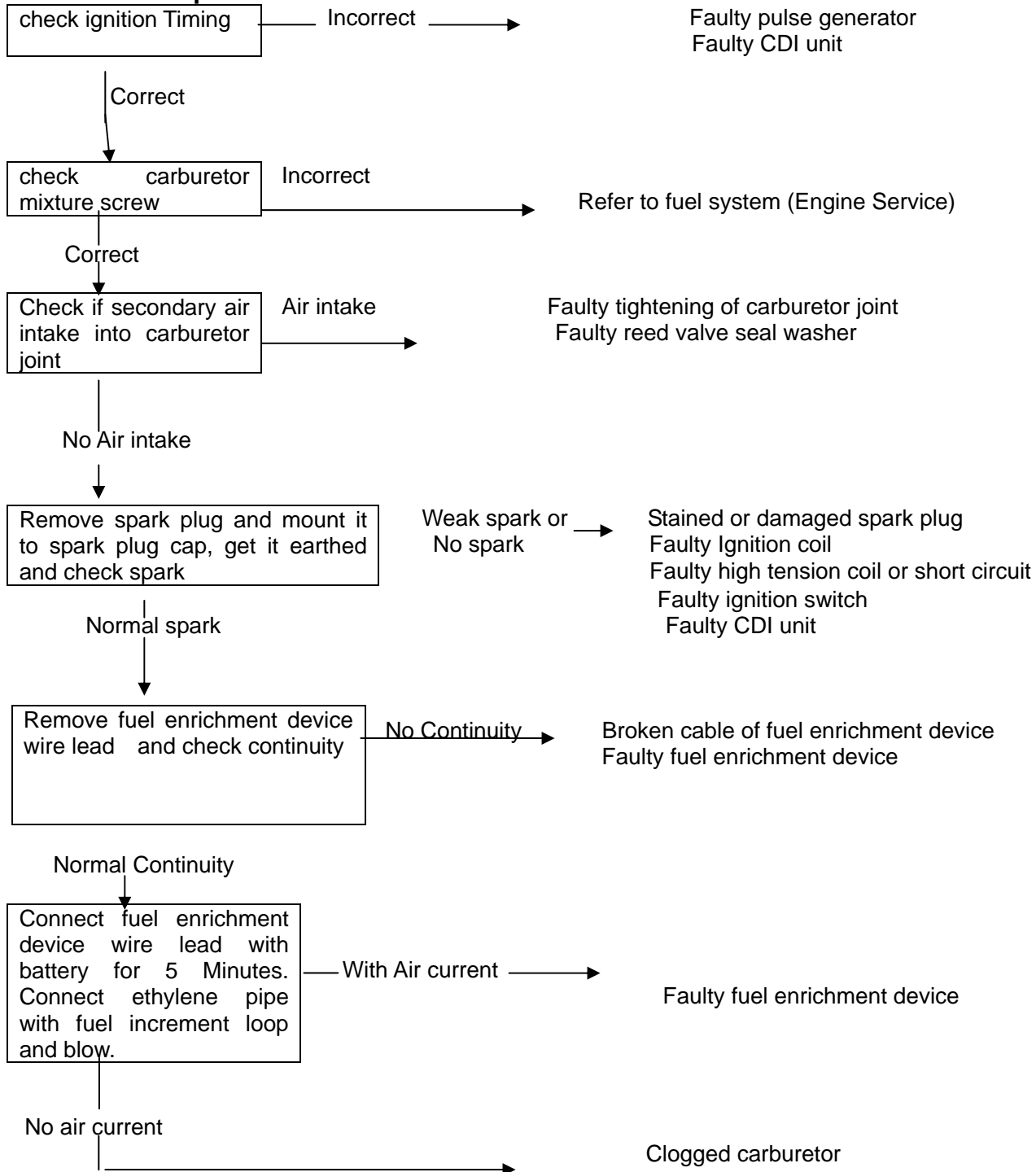

Poor Engine Performance in Middle or High Range

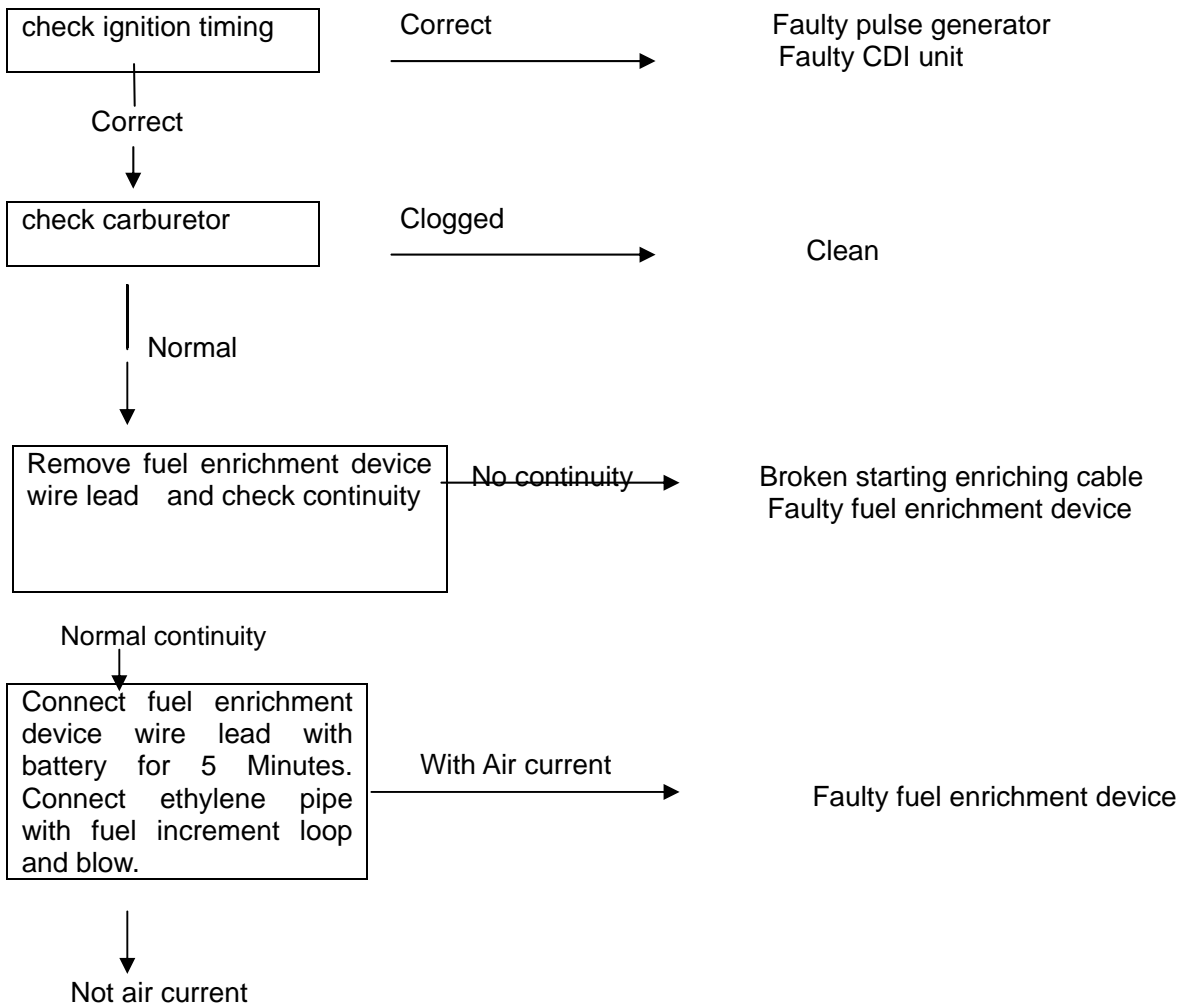

Conversion Table

Item	Conversion
Press	1kgf/cm ² =98.0665KPa 1KPa=1000Pa 1mmHg=133.322Pa=0.133322KPa
Torque	1kgf.m=9.08665N.m
Volume	1ml=1cm ³ =1cc 1l=1000 cm ³
Force	1kgf=9.80665N

Warning/Caution/Note

Please read this manual and follow its instructions carefully. To emphasize special information, the symbol and the words WARNING, CAUTION and NOTE have special meanings. Pay attention to the messages highlighted by these signal words.

Warning:

Indicates a potential hazard that could result in injury or death.

Caution:

indicates a potential hazard that could result in vehicle damage.

Note:

provides key information to make procedures easier or instruction clearer.

Please note, however, that the warnings and cautions contained in this manual can't possibly cover all the potential dangerous information to the servicing, or lack of the vehicle. Except WARNINGS and CAUTIONS stated in this manual, mechanic should have a basic understanding of the mechanical ideas and the procedure of machine repair. If mechanic can't master all the troubleshooting operation, please consult with qualified mechanic for advice.

General Precautions	10-2
Fuel, Oil and Coolant.....	10-3
Brake-in	10-3
Engine Exterior and Engine No.....	10-4
Engine Specification.....	10-5
Overhaul Data.....	10-6
Tightening Torque Table.....	10-10
Tools.....	10-12
Materials for Operation and Fixing	10-14

GENERAL PRECAUTIONS

Warning ! Proper service and repair procedures are important for the safety of operator and the safety and reliability of the vehicle.

- When two or more persons work together, keep reminding each other for safety purpose.
- When start the engine indoors, make sure that the exhaust gas is forced outdoors.
- If use hazardous or flammable material, please strictly operate according to manufacturer's operation manual. Operate in a well- ventilated place.
- Never use gasoline as a cleaning solvent.
- Do not touch the engine oil, radiator or muffler with bare hands to avoid scalding before it is cooled.
- Check all the lines, and fittings related to the system for leakages, after repairing fuel, cooling, lubricating or exhaust system .
- Do not dispose used oil, coolant or defective parts optionally for environmental purpose.

CAUTION:

- Use genuine CFMOTO parts or their equivalent.
- Place and store the disassembled parts separately in order for correct assemble.
- Use special tools according to service manual.
- Make sure that all parts used in reassembly are clean, lubricated them when specified.
- Use the special lubricants, sealants and greases.
- Pre-tighten the bolts, nuts and screws, then tighten according to the specified torque, from big to small and from inner side to outer side.
- Fix torque screw with torque wrench, clean grease or oil from the screw thread before fixing.
- Check the parts after disassembling, clean the parts before measuring.
- Check parts for tightness and proper operation, after assembling.
- Replace the disassembled washers, o-rings, seals, locknuts, lockwashers, cotter pins, circlips with new ones.

FUEL, OIL, COOLANT**Fuel**

Use unleaded gasoline with octane number over 90.

OIL

Use a premium quality 4-stroke motor oil to ensure longer service life of your vehicle. Use only oils that meet API service classifications SF or SG and that have a viscosity rating of SAE10W/40. If oil with a rating of SAE 10W/40 is not available, select an alternative according to the chart.

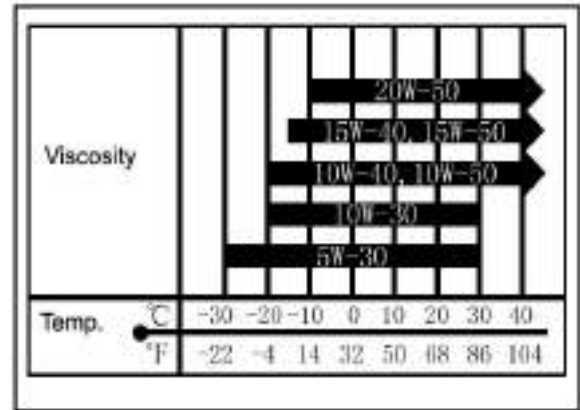
**ENGINE COOLANT**

Since antifreeze also has corrosion and rust-inhibiting properties, always use coolant containing antifreeze, even if the atmospheric temperature does not go below the freezing point.

It is suggested that the freezing point of antifreeze should be 5°C lower than the lowest ambient temperature where the vehicle is used.

Recommended Coolant: -35°C antifreeze, corrosion-resistant, high boiling point coolant

Warning! Coolant is poisonous. Never drink it. Store it properly.

Caution: DO NOT mix coolant with that of other engines.

BREAK-IN PROCEDURES

During manufacturing only the best possible material are used and all machined parts are finished to a very high standard. It is still necessary to allow the moving parts to "BREAK-IN" before subjecting the engine to maximum stresses. The future performance and reliability of the engine depends on the care and restraint exercised during its early life. Refer to the following break-in engine speed recommendations.

For better performance and durability, a new engine requires a run-in time of 20 hours as under:

0~10 Hours:

Avoid continuous operation above half throttle. Allow a cooling off period of five to ten minutes after every hour of operation. Vary the speed of vehicle from time to time. Do not operate it at one set throttle position.

10~20 Hours

Avoid prolonged operation above 3/4 throttles. Rev the vehicle freely but do not use full throttle at any time.

Note: Keep the daily maintenance during the run-in time and eliminate the troubles, if any. After 20h run-in time, do the maintenance according to the owner's manual for normal operation of the ATV.

Engine Exterior and Engine No

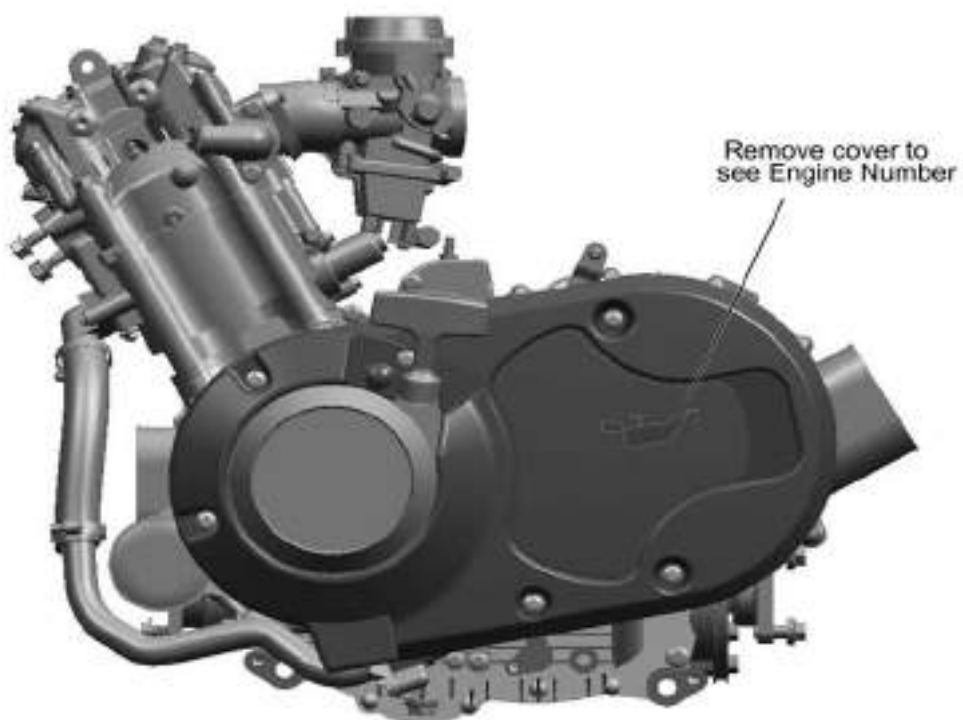

View From Engine Left Side



View From Engine Right Side

Engine Specification

REF. NO.	ITEM		Type/SPECIFICATION	
1	Type		Single Cylinder, 4-Stroke, Liquid-cooled, 4 Valve, SOHC	
2	Bore and stroke		87.5mm×82.0mm	
3	Displacement		493ml	
4	Compression ratio		10.2: 1	
5	Lowest continuous idle speed with load		1300r/min±100r/min	
6	Starting type		Electrical starting/ Recoil Starting	
7	Electrical System	Ignition / Ignition Timing	CDI Magneto ignition/BTDC10°1500r/min	
		Spark Plug/ Spark Plug Gap	DPR7EA-9 (NGK)/0.8mm-0.9mm	
		Magneto	Permanent Magnet AC Type	
8	Combustion System	Combustion Chamber	Triangle Combustion Chamber	
		Carburetion Type/Model	Vacuum Diaphragm Type/MIKUNI BSR36-89	
		Air Filter	Sponge Element Filter	
		Gasoline	RQ-90	
9	Valve System	Valve Type	SOHC/Chain Drive	
10	Lubrication System	Lubrication Type	Pressure & Splash	
		Oil Pump	Rotor Type	
		Filter Type	Full Flow Filter Screen	
		Oil Type	SAE10W-40/SF	
11	Cooling System	Cooling Type	Closed Coolant Circulation	
		Coolant Type	—35°C Rust-resistant antifreeze	
12	Drive System	Clutch type	Wet, Auto-centrifugal	
		Operation Mode	Automatic(CVT)+Parking and Gear Shifting	
		Gears	2 Forward Gears + 1 Reverse Gear	
		Shift Type/Sequence	Hand Operation/L-H-N-R-P	
		(CVT) Gear Ratio	2.88-0.70	
		Transfer Gear Ratio	Final Ratio	1.333(24/18, bevel gear)
			Secondary Ratio	1.952(41/21)
			Gears	Low Gear:2.25(36/16) High Gear :1.35(27/20) Reverse Gear:1.471(25/17)
Total	Low Gear:5.857, High Gear:3.514,Reverse Gear:3.828			
13	Overall Dimension		610×568×519mm	
14	Net Weight		70kg	
15	Output type		Front and rear shaft output	
16	Rotational Direction of Engine Output		Clockwise (from behind engine at forward gear)	

Overhaul Data

Item	Standard		Service Limit	Remark
Valve Head Diameter	IN	30.6	-----	
	EX	27.0		
Valve Clearance	IN	0.05-0.10	-----	
	EX	0.010-0.037		
Clearance Between Valve Guide and Valve Stem	IN	0.010-0.037	-----	
	EX	0.030-0.057		
Inner Diameter of Valve Guide	IN & EX	5.000-5.012	-----	
Outer Diameter of Valve Stem	IN	4.975-4.990	-----	
	EX	4.955-4.970	-----	
Valve Stem Play	IN & EX	-----	0.05	
Length of Valve Stem End	IN & EX	2.9-3.1	2.3	
Valve Head Thickness	IN & EX	-----	0.5	
Play of Valve Head Seal	IN & EX	-----	0.03	
Width of Valve Seat Seal	IN & EX	0.9-1.1	-----	
Valve Spring Free Length	IN & EX	40	38.8	
Valve Spring Tension	IN & EX	182-210N,(when compressed to 31.5mm)	-----	
Cam Height	IN	33.430-33.490	33.130	
	EX	33.500-33.560	33.200	
Clearance Between Camshaft Outer Diameter & Hole	Φ22	0.032-0.066	0.150	
	Φ17.5	0.028-0.059	0.150	
Camshaft Outer Diameter	Φ22	21.959-21.980	-----	
	Φ17.5	17.466-17.484	-----	
Inner Diameter of Camshaft Hole	Φ22	22.012-22.025	-----	
	Φ17.5	17.512-17.525	-----	
Camshaft Play			0.10	
Inner Diameter of Rocker Arm	IN & EX	12.000-12.018	-----	
Outer Diameter of Rocker Arm	IN & EX	11.973-11.984	-----	
Cylinder Head Distortion		0.03	0.05	
Cylinder Head Cover Distortion		0.03	0.05	

Cylinder + Piston + Piston Ring + Connecting Rod

Item	Standard		Service Limit	Remark
Cylinder Pressure	1000KPa		-----	
Cylinder-Piston Clearance	0.030-0.051		0.15	
Piston Skirt Diameter	87.460-87.480 (10mm form skirt end)		87.380	
Inner Diameter of Cylinder	87.500-87.522		-----	
Cylinder Joint Face Distortion	0.015		0.05	
Piston Ring Free Gap	Top Ring	R About 11.7	8.9	
	2 ND Ring	R About 12	9.5	
Piston Ring Gap In Bore	Top Ring	0.15-0.30	0.60	
	2 ND Ring	0.15-0.30	0.60	
Piston Ring Groove Clearance	Top Ring	0.04-0.08	0.180	
	2 ND Ring	0.03-0.07	0.150	
Piston Ring Thickness	Top Ring	0.97-0.99	-----	
	2 ND Ring	1.17-1.19	-----	
Piston Ring Groove Width	Top Ring	1.03-1.05	-----	
	2 ND Ring	1.22-1.24	-----	
	Oil Ring	2.51-2.53		
Inner Diameter of Piston Pin Hole	23.002-23.008		23.030	
Outer Diameter of Piston Pin	22.995-23.000		22.980	
Inner Diameter of Connecting Rod Small End	23.006-23.014		23.040	
Clearance of Connecting Rod Big End	0.10-0.55		1.0	
Thickness of Connecting Rod Big End	24.95-25.00			
Crankshaft Play	0.03		0.08	

Lubrication

Item	Standard		Service Limit	Remark
Clearance between Inner and Outer Rotors	0.03mm-0.10mm		0.15mm	
Clearance between Outer Rotor and Oil Pump Body	0.03mm-0.10mm		0.12mm	
Oil Pressure	130Kpa-170Kpa (3000r/min)		-----	
Oil Type	SAE10W-40, API SF or SG		-----	
Oil Capacity	When changing	1900ml	-----	
	When Replacing Filter	2000ml	-----	
	Engine Repair	2200ml	-----	

Clutch + Transfer

Item	Standard	Service Limit	Remark
Clutch Plate Inner diameter	140.00-140.15	140.50	
Clutch Engagement Speed	1800-2400r/min	-----	
Clutch Lock Speed	3300-3900r/min	-----	
Drive Belt Width	35.2	33.5	
Free length of Secondary Sheave Spring	168	160	
Shift Fork to Groove Clearance	0.10-0.40	0.50	
Thickness of Left Shift Fork	5.8-5.9	-----	
Thickness of Right Shift Fork	5.8-5.9	-----	
Shift Fork Groove Width	6.0-6.2	-----	
Drive Output Gear Groove Width	6.0-6.2	-----	

Cooling System

Item	Standard		Service Limit	Remark
Thermostat Valve Opening Temperature	68-74℃		-----	
Thermostat Valve Lift	3.5-4.5mm (at 95℃)		-----	
Radiator Cap Opening Pressure	93.3-122.7Kpa		-----	
Corresponding Relation Between Water-temperature Transducer' resistance and water-temperature	Water Temperature (℃)	Resistance (Ω)	-----	
	50	154±16		
	80	52±4		
	100	27±3		
Functioning Temperature of Thermostat	OFF--ON	88℃	-----	
	ON--OFF	82℃	-----	
Coolant Type	-35℃ antifreeze, corrosion-resistant, high boiling point coolant		-----	

Carburetor

Item	Standard	Remark
Carburetor Type	MIKUNI BSR36-89	
I.D. Mark	07G0	
Carburetor Barrel Size	36mm	
Engine Idle Speed	1300r/min \pm 100r/min	
Main Jet (MJ)	N10221-130#	
Main Air Jet (MAJ)	MD13/24-35#	
Jet Needle (JN)	J8-5E26	
Needle Jet (NJ)	785-401011-P-OM	
Pilot Jet (PJ)	N224103-22.5#	
Pilot Jet Screw (PS)	604-16013-1A	

Electrical System

Item	Standard	Remark
Spark Plug	Type	NGK;DPR7EA-9
	Gap	0.8-0.9
Spark Character	>8mm	
Ignition coil Resistance	Primary	0.1 Ω -0.5 Ω
	Secondary	12 Ω -22 Ω
Magneto Coil Resistance	Pick-up	150 Ω -300 Ω
Magneto Voltage (Without load)	>100V(AC),5000r/min	
Max. Magneto Output Power	300W, 5000r/min	
Regulated Voltage	13.5V-15.0V, 5000r/min	
Primary Peak Voltage of Ignition Coil	>150W	
Starter Relay Coil Resistance	>120W	
Starter Relay Coil Resistance	3 Ω -5 Ω	
Auxiliary Starter Relay Coil Resistance	90-100 Ω	

Tightening Torques

Item	Quantities	Thread Size (mm)	Tightening Torque (N.m)	Remark
Reverse Gear Sensor	1	M10*1.25	20	
Spark Plug	1	M12*1.25	18	
Water-temperature Sensor	1	Rc1/8	8	Apply Thread Locker
Adjusting Nut, Valve Clearance	4	M5	10	
Nut, Primary Sheave	1	M20*1.5	115	
Nut, Secondary Sheave	1	M20*1.5	115	
Ring Nut, Secondary Sheave	1	M30*1	100	
Nut, Front Drive Shaft	1	M14*1.5	97	
Nut, Drive Bevel Gear	1	M22*1	145	
Nut, Driven Bevel Gear	1	M16*1.5	150	
Fixing Nut, Clutch	1	M18*1.5	70	Counter Clockwise
Limit Nut, Drive Bevel Gear Bearing	1	M60	110	Apply Thread Locker
Nut, Universal Joint Yoke	1	M55	80	Counter Clockwise, Apply Thread Locker
Bolt, Rocker Arm Shaft	2	M14*1.25	28	
Oil Drain Bolt	1	M12*1.5	30	
Bolt, Overriding Clutch	6	M8	26	Apply Thread Locker
Bolt, Magneto Stator	3	M6	10	Apply Thread Locker
Screw, CVT Plate	3	M6	10	Apply Thread Locker
Bolt, Oil Pipe	2	M14*1.5	18	
Bolt, Oil Pump	3	M6	10	
Bolt, Pressure Release Valve	2	M6	10	
Bolt, Drive Bevel Gear Cover	4	M8	32	
Bolt, Driven Bevel Gear Cover	4	M8	25	
Bolt, Gear Limit	1	M14x1.5	18	
Bolt, Recoil Starter	1	M10x1.25	55	

Tightening Torques

Item	Quantities	Thread Size (mm)	Tightening Torque (N.m)	Remark
Bolt, Crankcase	14	M6	10	
	3	M8	25	
Bolt, Driven Sector Gear	1	M6	12	
Bolt, Oil Filter	1	M20x1.5	63	
Bolt, Oil Starter Motor	2	M6	10	
Bolt, Cylinder Head	4	M10	38	
Bolt, Cylinder Head	2	M6	10	
	1	M8	25	
Bolt, Cylinder (Upper & Lower)	4	M6	10	
Bolt, Cylinder Head Cover	12	M6	10	
Bolt, Chain Tensioner	2	M6	10	
Nut, Chain Tensioner	1	M8	8	
Bolt, Fan Motor	3	M6	10	
Bolt, Thermostat Housing	2	M6	10	
Bolt, Water Pump Cover	3	M6	6	
Bolt, Water Pump	2	M6	10	
Fixing Bolt, Timing Chain	2	M6	15	Apply Thread Locker
Other Bolts		M5	4.5-6	
		M6	8-12	
		M8	18-25	

Maintenance Tools

Measurement Tools			
No.	Description	Specification	Purpose
1	Vernier Caliper	0-150mm	For measuring the length and thickness
2	Micrometer	0-25mm	For measuring outer diameters of rocker arm, valve stem and camshaft
3	Micrometer	25-50mm	For measuring the max. lift of camshaft
4	Micrometer	75-100mm	For measuring piston skirt
5	Cylinder Gauge		For measuring cylinder bore diameter
6	Small Bore Gauge	10-34mm	For measuring inner gauge of rocker arm, piston pin bore, connecting rod small end bore
7	Dial Indicator	1/100	For measuring the play
8	Straightedge Gauge		Plane measuring
9	Feeler Gauge		Plane and valve clearance measuring
10	Fuel Level Gauge		For measuring the carburetor fuel level
11	Thickness Gauge		For measuring the clearance
12	Spring Balance		For measuring the spring tension
13	Tachometer		For measuring engine speed
14	Oil Pressure Gauge		For measuring oil pressure
15	Compression Gauge & Adapter		For measuring cylinder compression
16	Radiator Cap Tester		For measuring radiator cap opening pressure
17	Ohmmeter		For measuring resistance and voltage
18	Ammeter		For measuring current/switches
19	Thermometer		For measuring liquid temperature
20	Timing Light		For checking the ignition timing
21	Torque Wrench		For measuring the tightening torque
General-purpose and Auxiliary Tools			
22	Alcohol Burner		Heating up
23	Magnetic Stand		For micrometer
24	Slab		Auxiliary tool for measuring
25	V-block		For measuring the play
26	Tweezer		For installation of valve cotter
27	Circlip Pliers		For removal and installation of circlips
28	Long Nose Pliers		For removal and installation of retainers
29	Impact Driver		For removal of cross-headed bolts
30	(-) Driver		
31	(+) Driver		

Special Tools

No.	Description	Specifications	Purpose
1	Spark Plug Wrench		Removal and installation of spark plug
2	Clutch Holder		For removing/installing clutch carrier nuts
3	Oil Filter Wrench		Removal and installation of oil filter cartridge
4	Piston Pin Puller		For removal of piston pin
5	Flywheel Puller		For removal of magneto rotor
6	Crankcase Separating Tool		For separation of left and right crankcase
7	Crankshaft Remover		For removal of crankshaft from left crankcase
8	Crankshaft Installation Set		For installing crankshaft to left crankshaft
9	Valve Spring Compressor		For removal and installation of valve spring
10	Valve Seat Cutter		For valve-seating
11	Ring Nut Wrench		Removal/installation of CVT secondary sheave
12	Sheave Holder		Removal/installation of CVT secondary sheave
13	Sheave Spring Compressor		Removal/installation of CVT secondary sheave
14	Couple Gear/Middle Shaft Tool		Removal/installation of the coupling gear nut
15	Bearing Driver	Set	For installation of bearing and oil seal
16	Bearing Removing Tool	Set	For removal of bearing
17	Oil Seal Removing Tool		For removal of oil seal
18	Universal Joint Holder		For removal/installation of the universal joint yoke nut

Materials for Operation and Fixing

Materials for engine operation engine oil, grease and coolant. Fixing materials include sealant, thread locker, etc.

Description	Type	Application Area	Remark
Lubricating Oil/Engine Oil	SAE10W-30 or SAE10W-40 or SAE20W-50 API service classifications SF or SG	Cylinder bore Crankcase Refer to Engine Lubrication System (→14-14)	capacity 1900ml (for changing oil) 2000ml (for replacing filet) 2200ml (for engine repairing)
Molybdenum lubrication oil		piston pin、valve stem、valve oil seal、camshaft	
Lubricating Grease	#3 MoS ₂ Lithium Base Grease	Oil seal lip, O-ring and sealing faces of other rubber seal materials, bearings with seals, CVT bearing and collar	
Coolant	-35°C antifreeze, corrosion-resistant, high boiling point coolant	Cooling system、Water-seal	Capacity according to radiator and water hose system
Joint Face Sealant		Joint face of crankcase, crankcase and cylinder, cylinder head and cover	
Thread Locker		Thread Parts	See 10-10, 10-11

Periodic Maintenance	14-2
Procedures of Maintenance and Adjustment.....	14-3
Valve Clearance.....	14-3
Engine Idle Speed.....	14-4
Spark Plug.....	14-4
Air Filter.....	14-5
Fuel Hose, Carburetor.....	14-6
Drive Belt.....	14-7
Inspection of Lubrication System.....	14-8
Inspection of Cooling System.....	14-10
Inspection of Cylinder Pressure.....	14-11
Inspection of Oil Pressure.....	14-12
Inspection of Clutch Engagement and Lock-up.....	14-13

Periodic Maintenance Table

The table below lists the recommended intervals for all the required periodic maintenance work necessary to keep the vehicle at its best performance and economy. Maintenance intervals are expressed in terms of kilometer, miles and hours, whichever occurs first.

Note: More frequent maintenance may be required on vehicles that are used in severe conditions.

Interval Item	Km	Initial 200	Every 1000	Every 2000	Remark
	Miles	Initial 100	Every 600	Every 1200	
	Hours	Initial 20	Every 40	Every 80	
Valve Clearance	I	--	I	I	IN: 0.05~0.10 EX:0.17~0.22
Idle Speed	I	I	I	I	1300±100r/Min
Spark Plug	--	--	I	I	No carbon deposit Gap: 0.8~0.9mm
	Replace every 6000Km				
Air Filter	--	C	C	C	Replace every 2000Km
Fuel Hose, Carburetor	--	--	I	I	Replace every 4 years
Clutch	--	--	I	I	
Drive Belt	--	I	R	R	
Engine Oil	R	--	R	R	
Oil Filter	R	--	R	R	
Coolant Level	I	I	I	I	
Water Hose & Pipes	I	I	I	I	
Coolant	Replace every 2 years				

I=Inspection and adjust, or replace if necessary

R=Replace

C=Clean

Procedures of Maintenance & Adjustment

This section describes the maintenance procedures for each item mentioned in the Periodic Maintenance Chart.

VALVE CLEARANCE

Inspect initially at 20-hour break-in and every 40 hours or every 1000km thereafter. Inspect the clearance after removing cylinder head.

Excessive valve clearance results in valve noise and insufficient valve clearance results in valve damage and reduced power.

Check the valve clearance at the period indicated above and adjust the valve clearance to specification, if necessary.

- Remove cover plate①, recoil starter②
- Remove inspection cap ③ on left crankcase.
- Remove 2 valve adjusting cover ④
- Turn the crankshaft until the line⑤ of T.D.C. on rotor is aligned with mark⑥ of inspection hole on left crankcase.
- Insert feeler gauge to check the clearance between the valve stem end and the adjust bolt on the rocker arm.

Valve Clearance (When cold)
IN: 0.05-0.10mm EX: 0.17-0.22mm

Note:

- The valve clearance must be adjusted when the engine is cold.
- Adjust the valve clearance when the piston is at the Top Dead Center (T.D.C.) on the compression stroke.

If the clearance is incorrect, bring it into the specified range using the special tool.

Loosen valve adjust bolt and nut, insert a feeler gauge between the valve stem end and valve adjusting bolt, tighten valve adjust bolt, make sure it slightly contacts the feeler gauge, tighten bolt and nut.

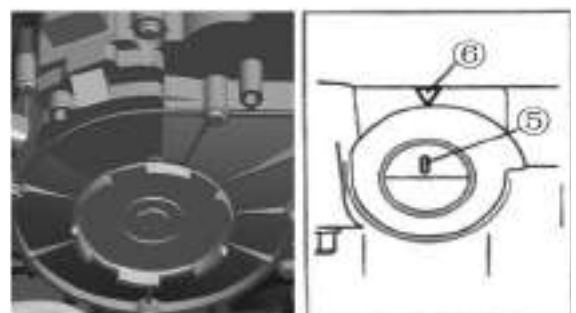
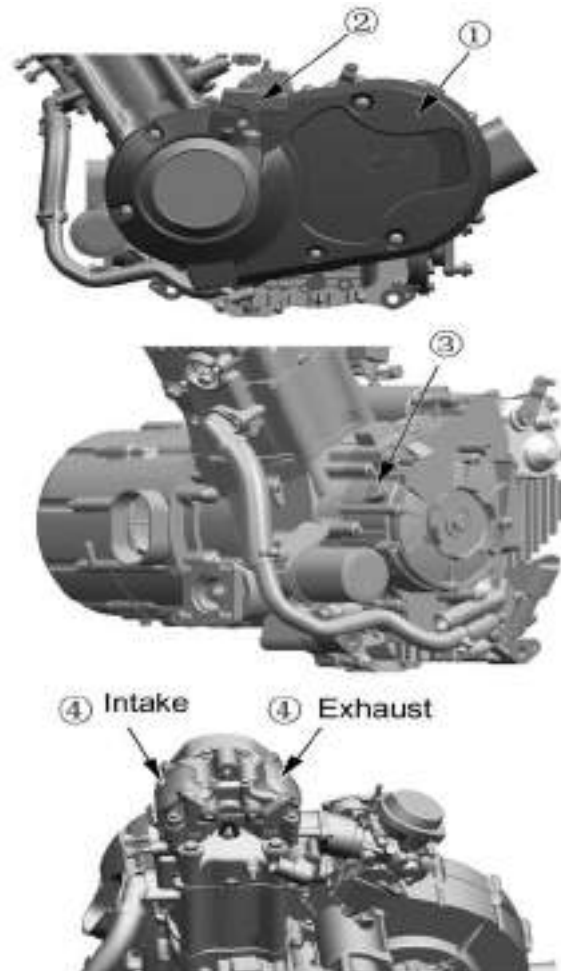

Take out the feeler gauge, measure the clearance.
If the clearance is incorrect, repeat the above steps until the proper clearance is obtained.

Locknut: 10 N.m

Caution:

Securely tighten the locknut after completing adjustment

Install:

2 valve adjusting cover;

Inspection cap;

Recoil starter;

Cover plate;

Apply a small quantity of THREAD LOCKER to recoil starter fixing bolts.

Tools:

Valve adjuster

Feeler gauge

Material:

Thread Locker

ENGINE IDLE SPEED

Inspect initially at 20 hours run-in and every 40 hours or 1000km thereafter.

Start the engine and warm it up for several minutes, measure engine speed with a tachometer. Set the engine idle speed between 1200~1400 r/min by turning the throttle stop screw of carburetor.

Engine idle speed: 1300r/min±100r/min

Note:

Make this adjustment when the engine is hot

Tool: Tachometer

SPARK PLUG

Inspect initially at 20 hours run-in and every 80 hours or 2000km thereafter. Replace every 6000km.

Remove the spark plug with a special tool

Specification: DER7EA-9(NGK)

If the electrode is extremely worn or burnt, or spark plug has a broken insulator, damaged thread, etc, replace the spark plug with a new one.

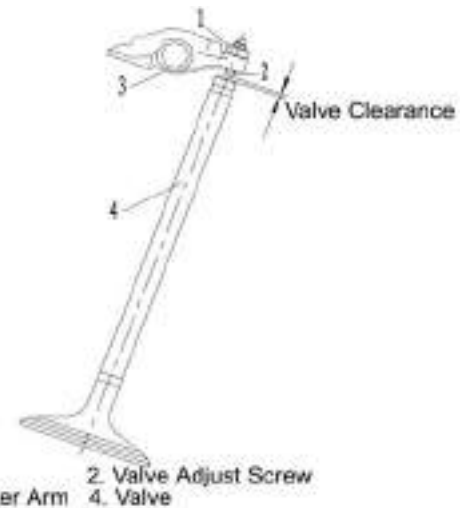

In case of carbon deposit, clean with a proper tool.

SPARK PLUG GAP

Measure the spark plug gap with a feeler gauge.

Out of specification: → Adjust

Spark plug gap: 0.8-0.9mm

Caution:

Check the thread size and reach when replacing the spark plug. If the reach is too short, carbon will be deposited on the screw portion of the spark plug hole and engine damage may result.

Installation:

Caution:

To avoid damaging the cylinder head threads; first, tighten the spark plug with fingers, and then tighten it to the specified torque using the spark plug wrench.

Tightening Torque: 18 N.m

Tool: Spark Plug Wrench, Feeler Gauge

Air Filter

Inspect every 40 hours or 1000 km, clean it if necessary.

If the air cleaner is clogged with dust, intake resistance will be increased, with a resultant decrease in power output and an increase in fuel consumption. Check and clean the air filter as following:

Remove fixing clamp① and top cover②

Note:

Be careful not to drop the o-ring into the air filter box that is attached to the air filter top cover.

Loosen screw③, remove filter element④, separate support⑤, filter element⑥ and filter element seat⑦.

- Fill a wash pan of a proper size with a non-flammable cleaning solvent A. Immerse the filter element in cleaning solvent and wash it.
- Press the filter element between the palms of both hands to remove the excess solvent. Do not twist or wring the element or it will tear.
- Immerse the element in engine oil B, and then squeeze out the excess oil leaving the element slightly wet.

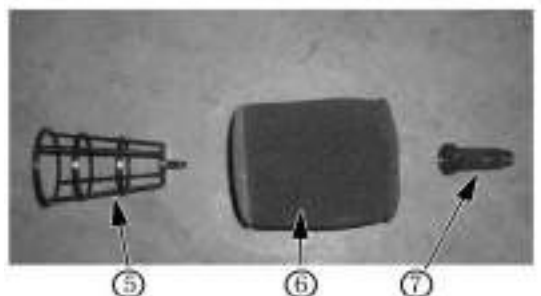
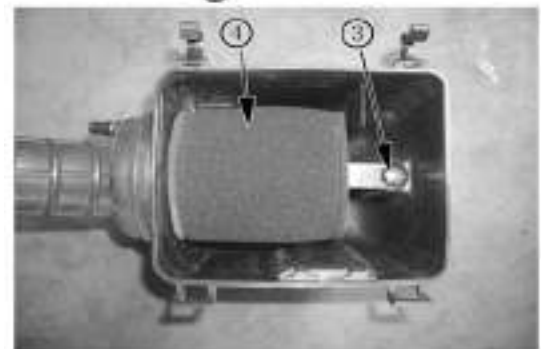
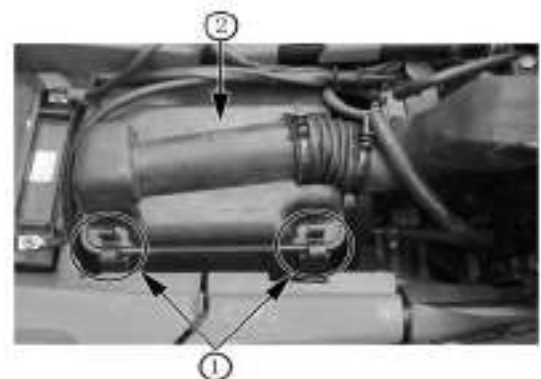
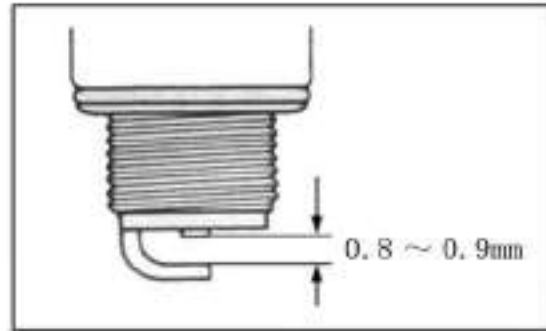

A--Non-flammable cleaning solvent
 B—Engine oil SAE#30 or SAE10W/40.

Warning:
 Never use with gasoline or low flash point solvents to clean the filter element

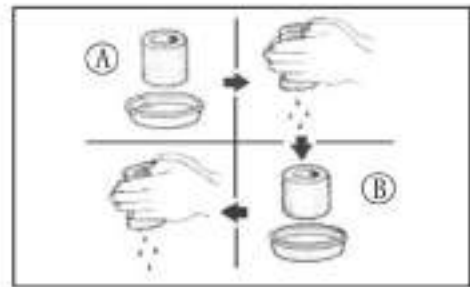

Inspect the filter element for tears. torn element must be replaced.

Note:
 If driving under dusty conditions, clean the air filter element more frequently. The surest way to accelerate engine wear is to operate the engine without the element or with torn element. Make sure that the air filter element is in good condition at all times.

Remove the drain plug[Ⓢ] of air box to drain out any water.

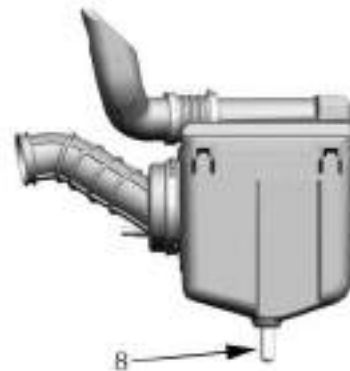

Fuel Hose

Inspect every 80 hours or 2000 km, replace every 4 years.

Inspect the fuel hose for damage and fuel leakage. If any damages are found, replace the fuel hose with a new one.



Drive Belt

Removal:

Remove CVT cover

Hold the primary sheave with special tool and loosen primary sheave nut.

Special Tool: Rotor Holder

Remove primary sliding sheave 1;
 Hold the secondary sheave with special tool and loosen secondary sheave nut. Remove secondary sheave together with drive belt.

Special Tool: Rotor Holder

Remove drive belt from secondary sheave

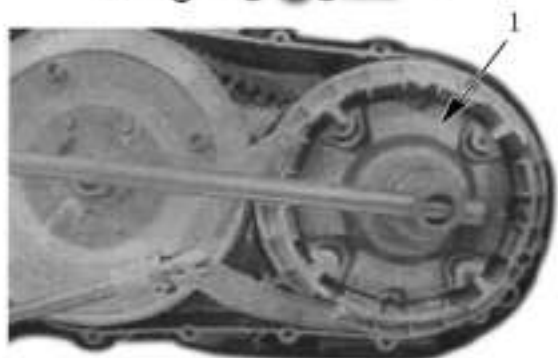

Inspection:

Inspect drive belt for wear and damage. If any cracks or damages are found, replace drive belt with a new one.

Inspect drive belt for width, if width is out of **service limit**, replace drive belt with a new one.

Service Limit: 33.5mm

Tool: Vernier Caliper

Installation

Reverse the removal procedure for installation. Pay attention to the following:

Insert drive belt, as low as possible, between secondary sliding sheave and primary fixed sheave.

Hold secondary sheave with a special tool and tighten the nut to the specified torque.

Nut, Secondary Sheave: 115 N.m

Install primary sheave and nut. Hold the primary sheave with a special tool and tighten the nut to the specified torque.

Nut, Primary Sheave:115N.m

Turn primary sheave, until the drive belt is properly seated and both the primary and secondary sheaves rotate together smoothly and without slipping.

Caution:

- **Fit the drive belt with the arrow on the drive belt points toward normal turning direction.**
- **The drive belt contact surface of the driven face should be thoroughly cleaned.**

Install CVT cover

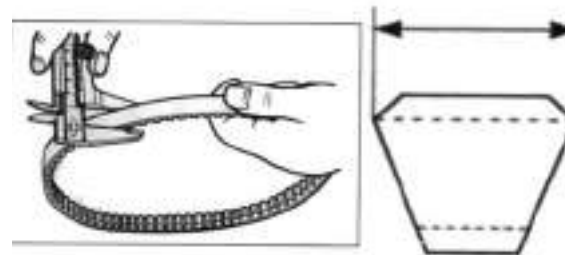

Inspection of Lubrication System

Replace engine oil and oil filter initially at 20 hours or 200km and every 80 hours or 2000km thereafter.

Check Engine Oil Level

- Keep the engine in a plan position.
- Remove the fixture A, fixture B, then remove the left side cover 1.
- Remove oil dip rod 2
- Clean oil dip rod, insert oil dip rod but do not tighten it.
- Take out oil dip rod and check if oil is between upper and lower limit.
- If the engine oil is insufficient, fill more oil until the sufficient oil is obtained.

Engine Oil: SAE10W/40 classification SF or SG

Note:

- Keep the engine in a plan position
- Do not tighten oil dip rod when measuring oil level

Replacing Engine Oil

- Remove left side cover 1, oil dip rod 2, drain bolt 3 and washer 4.
- Drain out the engine oil while the engine is still warm.
- Clean oil dip rod, drain bolt and washer with solvent.
- Install washer and drain bolt.

Drain Bolt: 30 N.m

- Fill engine oil. (about 1900ml)

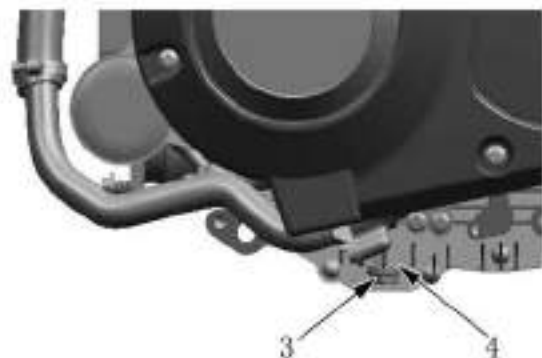
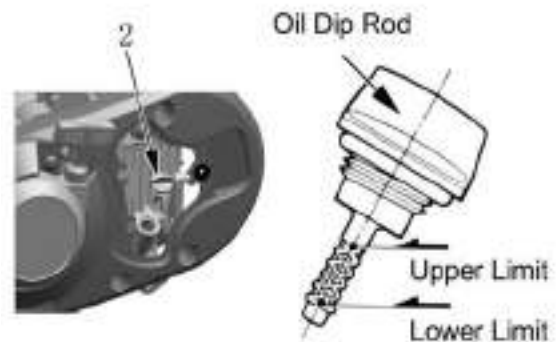
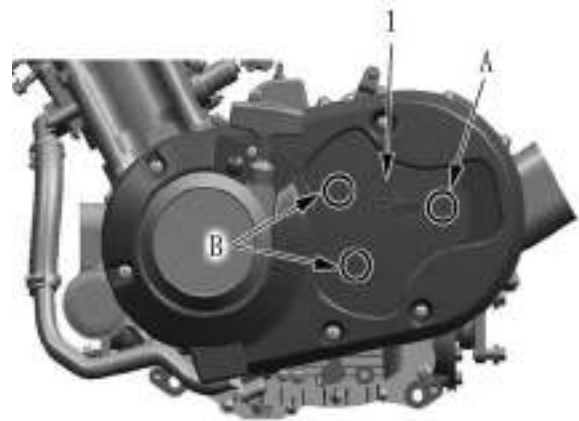

- Install oil dip rod, start the engine and allow it to run for several minutes at idling speed.
- Turn off the engine and wait for about 3 minutes, and then check the oil level on the dipstick.

Caution:

The engine oil should be changed when the engine is warm. If the oil filter should be replaced, replace engine oil at the same time.

Replacing Oil Filter

- Remove relative parts (see Replacing Engine Oil)
- Remove oil filter① with the special tool
- Install washer and drain bolt
- Install new oil filter with the special tool
- Fill engine oil (about 2000ml) and check (see Replacing Engine Oil)

Tool: Oil Filter Wrench

Engine Oil Capacity
 When replacing oil: 1.9L
 When replacing oil filter: 2.0 L
 Engine overhaul:2.2 L



Inspection of External Oil Pipe

Check external oil pipe for leakage or damage.

Leakage or Damage: → Replace

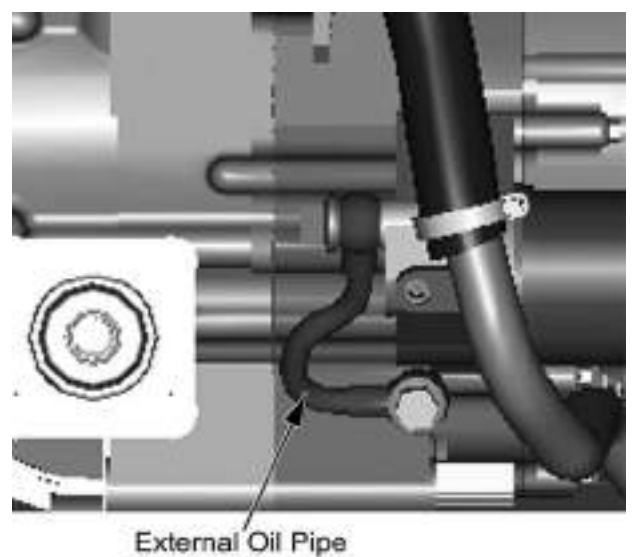

Inspection of Cooling System

Check initially at 40 hours or 1000km, replace coolant every 2 years.

Check radiator, reservoir tank and water hoses.

Leakage or Damage: → Replace

Check coolant level by observing the upper and the lower limit on the reservoir tank.

If the level is below lower limit, fill coolant until the level reaches the upper limit.

Replacing Coolant

- Remove radiator cap① and reservoir tank cap②.
- Place a pan below water pump, and drain coolant by removing drain plug③ and water hose④.
- Drain coolant from reservoir tank.

Warning !

- Do not open radiator cap when engine is hot, you may be injured by escaping hot liquid or vapor.
- Engine coolant is harmful. If coolant splashes in your eyes or clothes, thoroughly wash it away with water and consult a doctor. If coolant is swallowed, induce vomiting and get immediate medical attention.
- Keep coolant away from reach of children

- Clean radiator with fresh water, if necessary.
- Connect water hose④ and tighten drain bolt③ securely.
- Fill the specified coolant into the radiator.
- Loosen bleed bolt⑤ on water pump, when coolant flow from bleed bolt, tighten the bolt. Install radiator cap ①securely after filling coolant.
- Start the engine and keep it running for several minutes. After warm up and cooling down the engine, open radiator cap and check coolant. Fill the specified coolant until the level is between the upper and lower lines on the reservoir tank.

Caution:

Repeat the above procedures several times and make sure the radiator is filled with coolant and air is discharged.

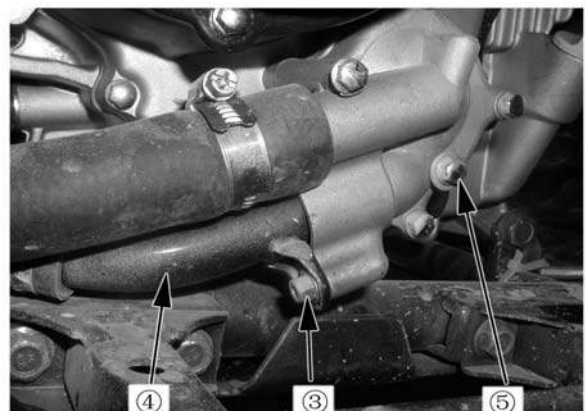
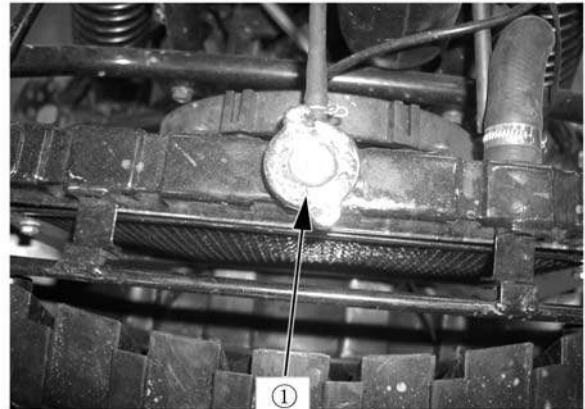

Fill coolant into the reservoir tank till between upper and lower limit.

Install reservoir tank cap.

Warning: Never mix with other brand

Inspection of Radiator Hose

Perform inspection every 40 hours or

Check radiator hose and clamp.

Leakage or Damage: →Replace

Inspection of cylinder pressure

Check cylinder pressure is necessary.

Cylinder Pressure: 1000kpa

A lower cylinder pressure may be caused by:

- Excessive wear of cylinder;
- Wear of piston or piston ring;
- Piston ring jam in groove;
- Poor closure of valve seat;
- Damaged cylinder gasket or other defects

Note: When cylinder pressure too low, check the above items.

Testing Cylinder Pressure

Note: Before testing of cylinder pressure, make sure that cylinder head bolts are tightened to the specified torque and valve clearance has been properly adjusted.

- Warm up the engine before testing;
- Make sure battery is fully charged;
- Remove spark plug 1;
- Install cylinder pressure gauge 2 in spark plug hole and tighten nut;
- Keep throttle full open;
- Press start button crank the engine a few seconds. Record the maximum reading of cylinder pressure.

Tools: Cylinder Pressure Gauge
Adaptor

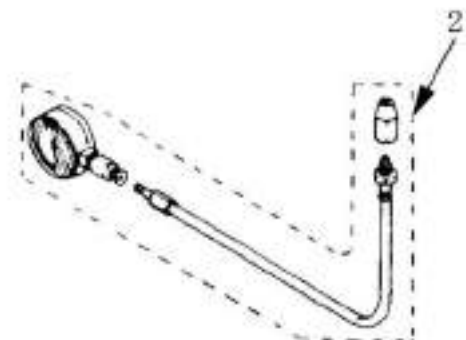

Inspection of Oil Pressure**Oil Pressure: 130~170kpa at 3000r/min**

Lower or higher oil pressure may be caused by:

I Oil pressure is too low

- Clogged oil filter;
- Leakage from oil passage;
- Damaged O-ring;
- Oil pump failure;
- Combination of above items;

II Oil pressure is too high

- Oil viscosity is too high;
- Clogged oil passage;
- Combination of above items;

Testing Oil Pressure

- Remove bolt①;
- Connect tachometer②with ignition coil
- Install oil pressure gauge③ and joint seat to main oil gallery.
- Warm up engine as per following:
Summer: 10 minutes at 2000r/min
Winter: 20 minutes at 2000r/min

After warming up, increase engine speed to 3000r/min, and record readings of oil pressure gauge.

- After testing, apply thread locker to the thread in the hole of main oil channel. Install bolt and tighten to the specified torque.

Tighten torque: 23N.m

Tools: Oil pressure gauge
Tachometer

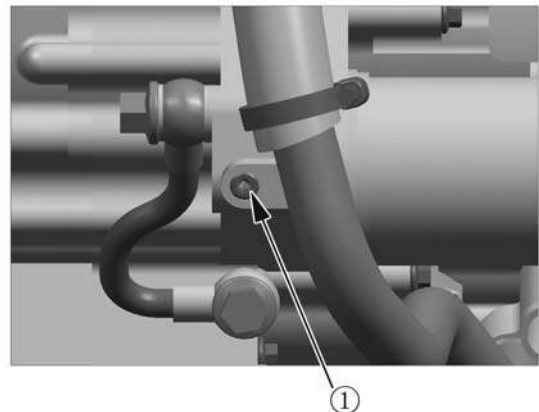

To: Ignition Coil

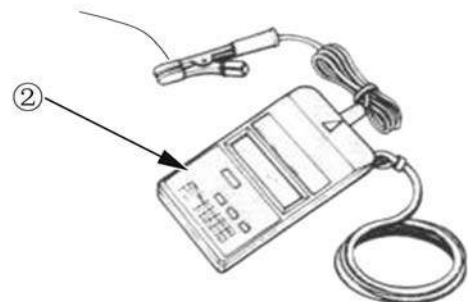

Inspection of Clutch Engagement and Lock-up

CF188 engine is equipped with a centrifugal type automatic clutch.

Before checking the initial engagement and clutch lock-up two inspection checks must be performed to thoroughly check the operation of the drive train.

I Initial Engagement Inspection

- Connect tachometer to ignition coil
- Start engine
- Shift gear lever to “High” position
- Slowly increase throttle and note down the engine speed (r/min) when the vehicle starts to move forward.

Engagement speed: 1800r/min~2400r/min

If the engagement speed is out of the above range, check the following:

- Clutch shoes
- Clutch shoe wheel
- Primary and secondary sheave

Refer to Chapter 12 for inspection of clutch

II Clutch Lock-up Inspection

- Connect the tachometer to ignition coil;
- Start the engine;
- Shift gear lever to “High” position;
- Apply front and rear brakes as firmly as possible;
- Fully open the throttle for a brief period and note the maximum engine speed obtained during the test cycle.

Lock-up Speed: 3300r/min~3900r/min

Warning:

Do not apply full power for more than 5 seconds or damage to clutch or engine may occur.

If the lock-up speed is out of the above range, check the following:

- Clutch shoes
- Clutch wheel
- Primary and secondary sheave

Refer to Chapter 12 for inspection of clutch

Tool: Tachometer

To: Ignition Coil



Δ Engine Removal/Installation Orders and the Relative Page Numbers

Item	Description	Disassembly	Inspection / Maintenance	Assembly	Remarks
Engine Periphery	Water Hose/Pipe	15-2	15-11	15-69	
	Left Side Cover	15-2	—	15-69	
	Recoil Starter	15-2	15-49	15-68	
↓ Engine Front Side	Spark Plug	15-2	15-4	15-68	
	Cylinder Head Cover	15-3	15-14	15-66	
	Tensioner	15-3	15-24	15-67	
	Camshaft	15-3	15-21	15-65	
	Cylinder Head/Tensioner Plate	15-4	15-15/15-23	15-64	
	Cylinder/Timing Chain Guide	15-4	15-24/15-23	15-64	
	Piston	15-5	15-25	15-62	
↓ Engine Left Side	Starting Motor	15-5	15-3	15-62	
	Oil Filter	15-6	15-9	15-62	
	Sector Gear	15-6	—	15-62	
	Water Pump	15-7	15-7	15-61	
	Sheave Drum	15-7	15-48	15-60	
	Left Crankcase Cover/ Magneto Stator	15-7	15-48	15-60	
	Magneto Rotor	15-7	15-47	15-60	
	Starting Driven Gear	15-8	15-47	15-59	
	Starting Dual Gear/Idle Gear	15-8	15-48	15-59	
	Oil Pump Sprocket and Chain	15-8	—	15-59	
↓ Engine Right Side	CVT Cover	15-9	15-51	15-58	
	Drive Belt	15-9	15-36	15-57	
	Primary Sheave/Secondary Sheave	15-9	15-30	15-57	
	CVT Housing/Clutch Outer Face	15-10	15-51	15-57	
	Clutch	15-10	15-28	15-56	
	Timing Chain	15-10	15-23	15-56	
↓ Engine Center	Gear Position Bolt	15-11	—	15-56	
	Right Crankcase	15-11	15-52	15-56	
	Front Output Shaft Components	15-11	15-43	15-55	
	Driven Bevel Gear Components	15-11	15-43	15-55	
	Shift Cam	15-12	15-40	15-55	
	Guide Bar, Fork	15-12	15-39	15-55	
	Drive Bevel Gear Components	15-12	15-42	15-55	
	Main Transmission Shaft	15-12	15-38	15-54	
	Transmission Counter Shaft	15-12	15-38	15-54	
	Balancer Shaft	15-12	15-46	15-54	
	Crankshaft	15-13	15-27	15-54	
	Oil Pump, Pressure-limiting Valve	15-13	15-41	15-53	
	Left Crankcase		15-52		

Notes: Arrowhead direction is for engine removal orders. Reverse the direction for assembly and installation

I

Engine Removal

ΔPreparation before engine removal

- Prepare a proper tray used for load of components
- Prepare necessary removal and assembly tools
- Drain up engine oil (→11-8)
- Drain up coolant (→ 11-10)

△ Engine Periphery

Water Hose/Pipe

- Remove water hose clamp① and②;
- Remove water hose③
- Remove screw④ and water hose⑤

Left Side Cover

- Remove 6 bolts(M6X20) of left side cover⑥
- Remove left side cover⑥

Recoil Starter

- Remove 4 bolts (M6X12) of recoil starter
- Remove recoil starter⑦

Inspection Plug

- Remove inspection plug⑧ with screwdriver

ΔEngine Front Side

Spark Plug

- Remove spark plug⑨ with special wrench
Tool: Spark Plug Wrench
- Turn crankshaft, align T.D.C. line A on magneto rotor with mark B of left crankcase

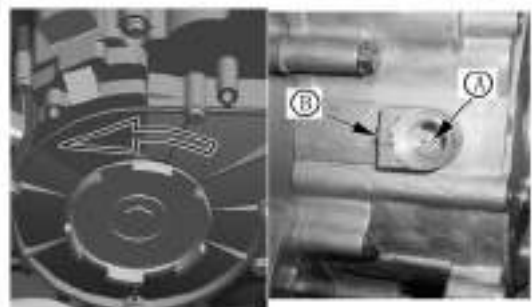

Cylinder Head Cover

- Remove valve adjusting cover
- Remove 12 bolts of cylinder head cover
- Remove cylinder head cover



Timing Chain Tensioner

- Remove screw plug ①, insert a flat screwdriver into slot of timing chain tensioner adjuster, turn it clockwise to lock tensioner spring;
- Remove tensioner fix bolt
- Remove tensioner and gasket

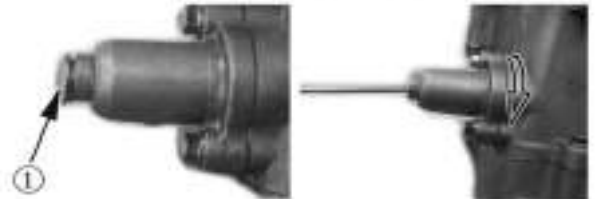

Camshaft

- Loosen timing sprocket bolt;
- Remove timing sprocket bolt and lock;



- Remove C-ring①
- Remove timing sprocket from camshaft, remove camshaft

Note: Take care not to drop spacer, bolt, bolt lock and C-ring into crankcase.

- Remove tensioner plate

Cylinder Head

- Remove cylinder head bolt

- Remove cylinder head bolts diagonally;
- Remove cylinder head

Note: Take care not to drop dowel pin into crankcase

Cylinder

- Remove dowel pin and cylinder head gasket
- Remove timing chain guide①



- Remove cylinder bolt
- Remove cylinder

Note: Take care not to drop dowel pin into crankcase

- Remove dowel pin and cylinder gasket

Note: When performing above removal process, be sure to hook up timing chain to prevent it from falling into crankcase

Piston

- Remove piston pin circlip① with long nosed pliers

Note: Put a clean rag under piston so as not to drop piston pin circlip into crankcase

- Remove piston pin②and piston③

Notes:

- When installing piston, make sure its identification conforms to that of cylinder;
- When removing piston pin, clean off burrs of piston pin hole and groove. If it's difficult to remove the piston, DO NOT hammer, use a special remover④

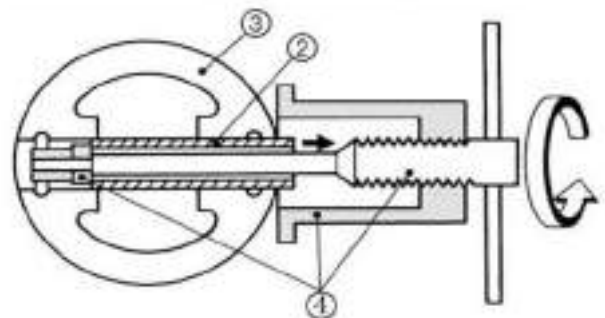

Tool: Piston Pin Remover

ΔEngine Left Side

Starting Motor

- Remove 2 bolts of starting motor
- Remove starting motor



Starting Motor

Oil Filter

- Remove oil filter with special tools

Tool: Oil filter Remover



Sector Gear

- Remove bolt 1 of gearshift rocker arm
- Remove gasket 2 and gearshift rocker arm 3

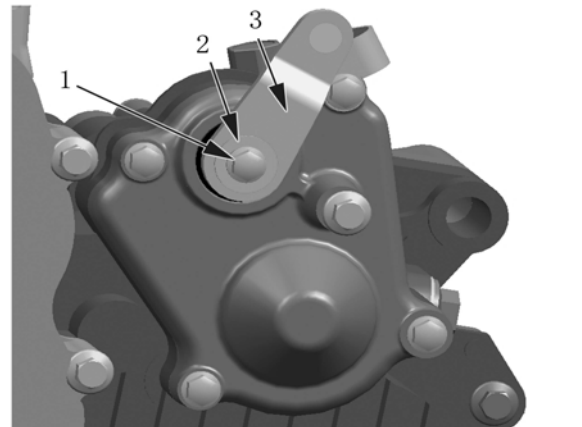

Cover, Gearshift Sector Gear

- Remove bolt of sector gear housing cover
- Remove wire clip and sector gear housing cover

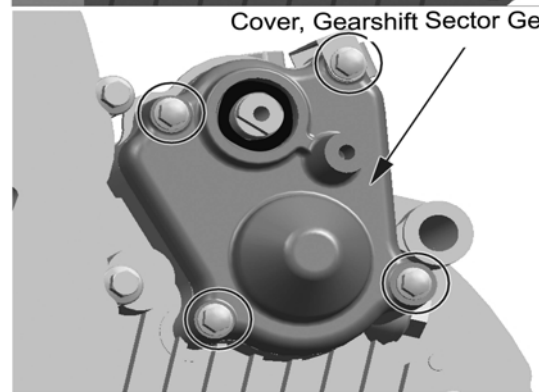

- Remove dowel pin and gasket
- Remove drive sector gear 4
- Remove bolt 5 of driven sector gear

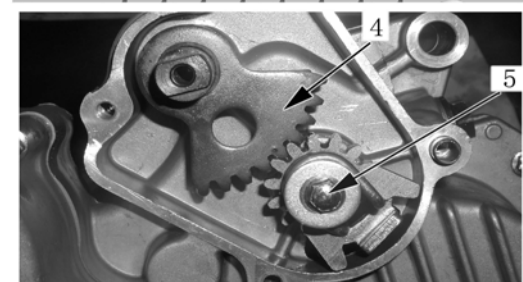

- Remove washer 6 and driven sector 7

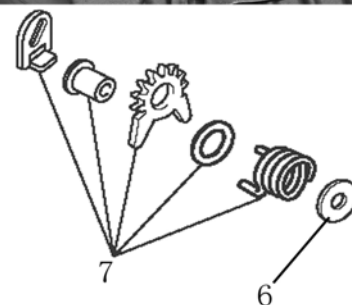

Water Pump

- Screw out bolt of water pump
- Remove water pump

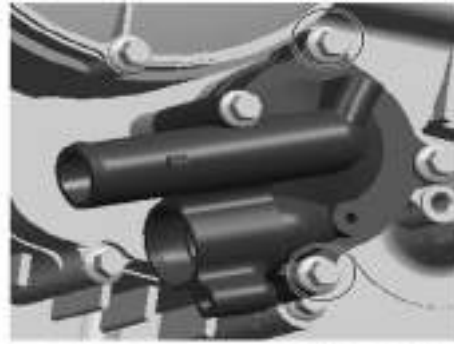

Sheave Drum

- Remove the sheave drum by using a suitable bar;
- Remove washer and sheave drum



Left Crankcase Cover

- Remove bolts;
- Remove left crankcase cover
- Remove dowel pin and gasket



Magneto Rotor

- Install attachment 1 to crankshaft end



- Install special tool to rotor thread;
- Remove rotor and woodruff key

Tool: Rotor Remover



Starting Motor Gear

- Remove driven gear 1 and needle bearing



- Remove spacer 2

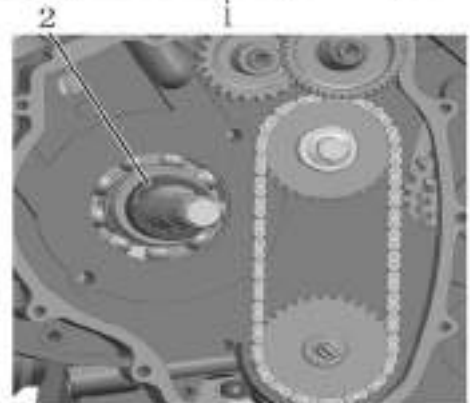

- Remove dual gear and shaft 3
- Remove idle gear and shaft 4

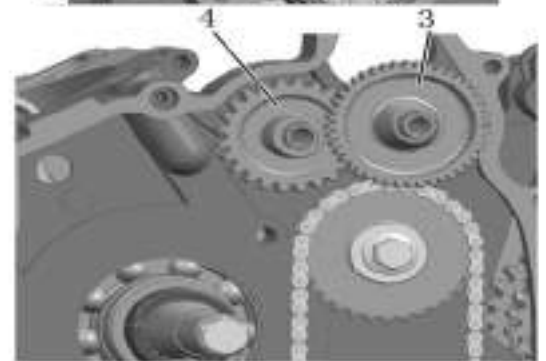

Oil Pump Sprocket and Chain

- Remove drive sprocket nut 5
- Remove C-ring 6
- Remove oil pump drive and driven sprockets and chain

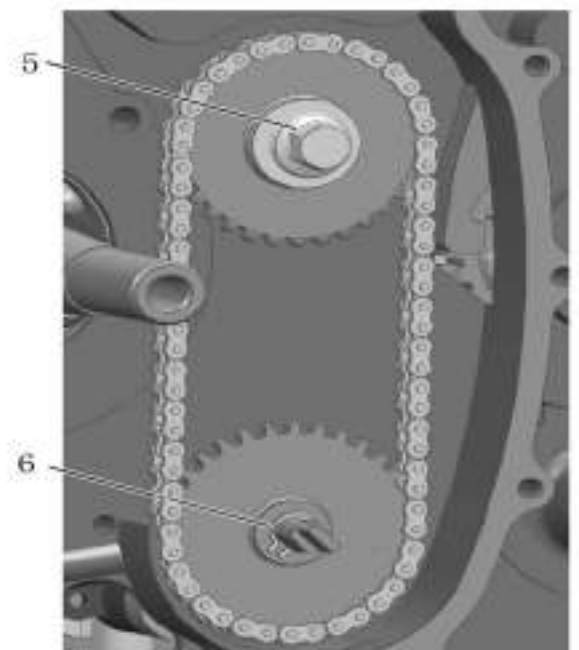

▲ Engine Right Side

CVT Cover

- Remove bolt of CVT cover
- Remove CVT cover
- Remove gasket and dowel pin

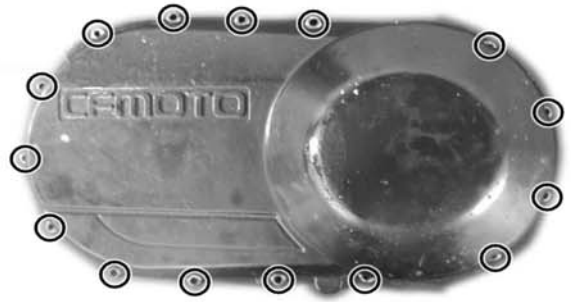

CVT(Continuously Variable Transmission)

- Remove primary sheave nut with special tool
- Remove primary sliding sheave

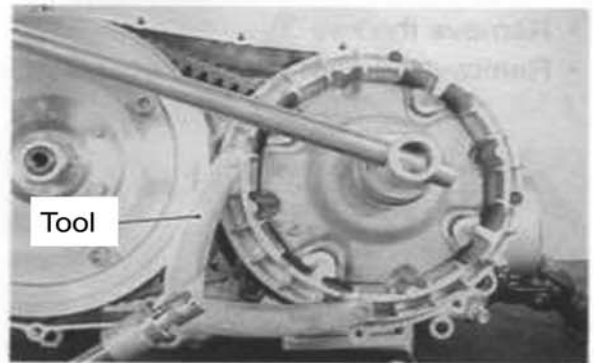

- Remove secondary sheave nut with special tools
- Remove secondary sheave
- Remove drive belt

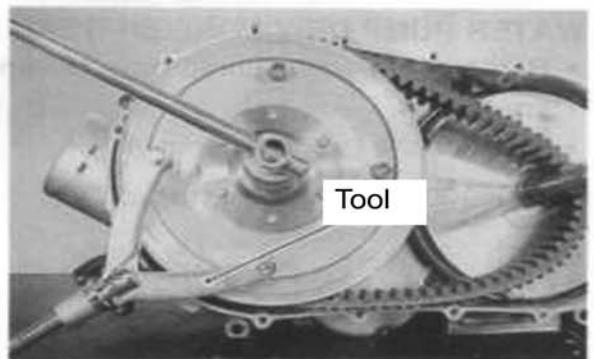

Tool: Sheave Holder

- Remove primary fixed sheave ①

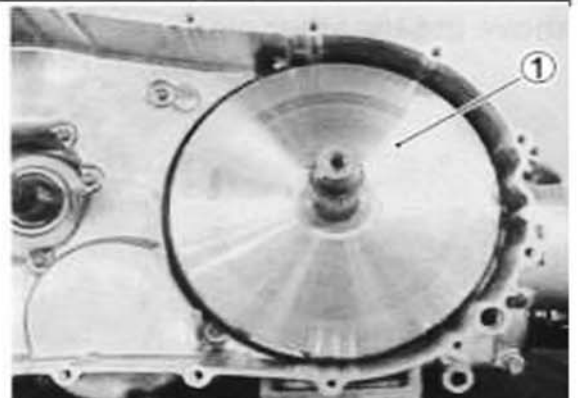

- Remove bolt for air guide plate.
- Remove air guide plate



CVT Case

- Remove bolt 1 of CVT case
- Remove nut 2 of CVT case
- Remove outer clutch face and CVT case
- Remove dowel pin, front and rear gasket



Clutch

- Remove one-way clutch
- Remove clutch shoe fixing nut with special tool
- Remove clutch shoe.

Note: The clutch shoe nut has left-hand threads.



Tool

Timing Chain

Timing Chain

- Remove timing chain

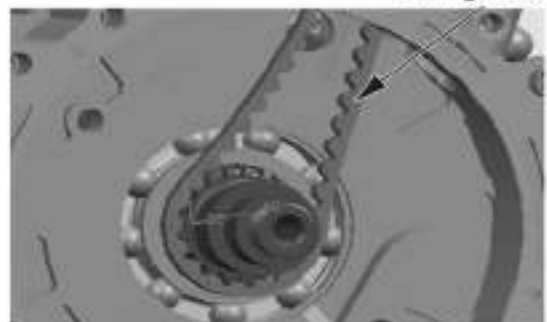

Engine Center

Gear position bolt

- Remove gear position bolt 1
- Remove spring and steel ball



- Right Crankcase
- Remove left crankcase bolts
- Remove right crankcase bolts
- Separate right crankcase with special tool



Caution

- The Crankcase separator plate should be parallel with the end face of crankcase
- Crankshaft should remain in the left crankcase half.

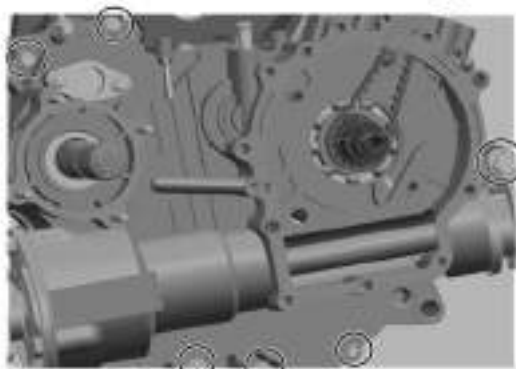

Tool: Crankcase separator



Driven Bevel Gear, Front Output Shaft

- Remove bevel gear cover bolt
- Remove driven bevel gear ③
- Remove front output shaft nut ④



- Remove Oil seal①, Bearing limit nut①
- Remove Front Output Shaft ④



Shift Cam, Fork/Shaft

- Remove Shift Cam⑤, Fork /Shaft⑥



Drive Bevel Gear

- Remove left crankcase from driven bevel gear



Drive Shaft, Drive Shaft

- Remove drive shaft⑦ and driven shaft⑦

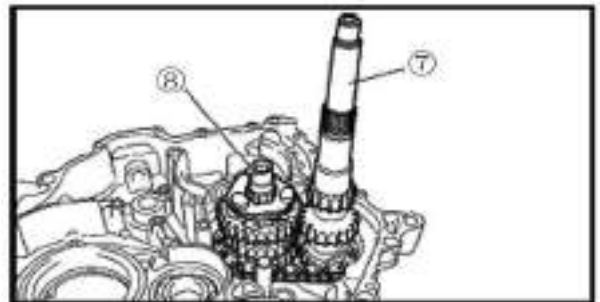

Balancer Shaft

- Remove balancer shaft



Balancer Shaft

Crankshaft

- Separate crankshaft from left crankcase with special tool

Tool: Crankshaft Separator

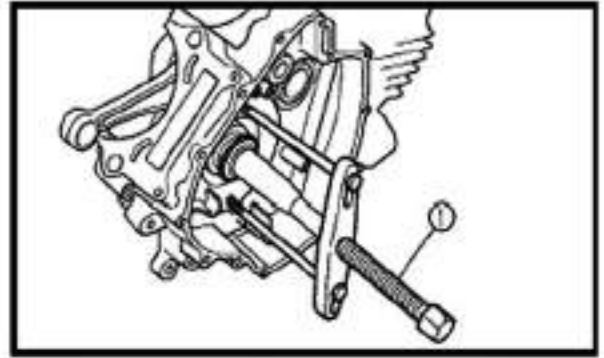

Oil bump, Relief Valve

- Remove oil bump and relief valve



Engine Components Inspection

Cylinder Head Cover

Disassembly

Caution: Each removed part should be identified to its location, and the parts should be laid out in groups designated as "Exhaust", "Intake", so that each will be restored to the original location during assembly.

- Remove rocker arm shaft bolts A
- Remove rocker arm shaft by using M6 bolts B

Cylinder Head Cover Distortion

Clean off sealant from the fitting surface of cylinder head cover, place cylinder head cover on a surface plate and measure distortion with a thickness gauge.

Cylinder head Cover Distortion

Limit: 0.05mm

Tool: Thickness Gauge

Distortion out of range: → Replace

Note: Cylinder head cover and cylinder head should be replaced together.

Rocker Arm Shaft

- Measure out diameter of rocker arm shaft with a micrometer.

Rocker Arm Shaft O.D.: (IN, EX)

Limit: 11.973~11.984mm

Tool: Micrometer (0~25mm)

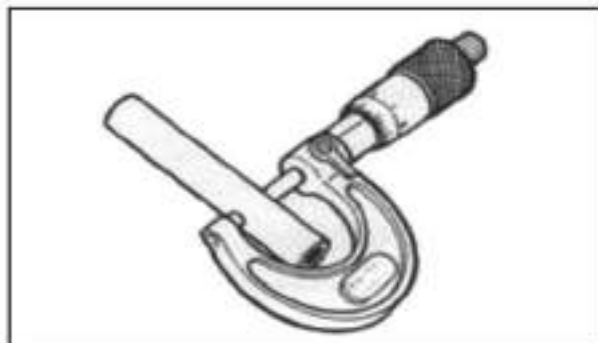
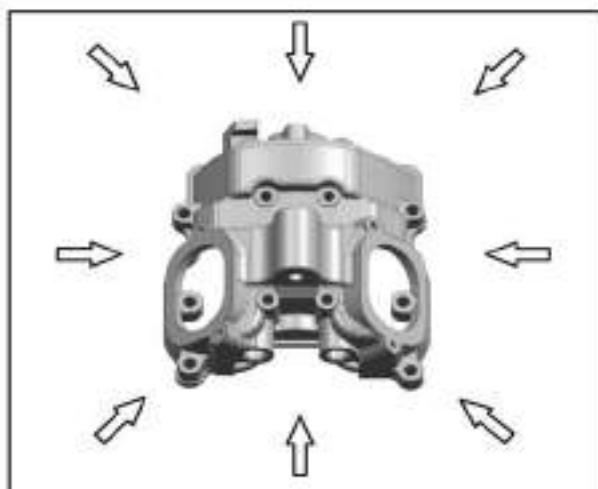
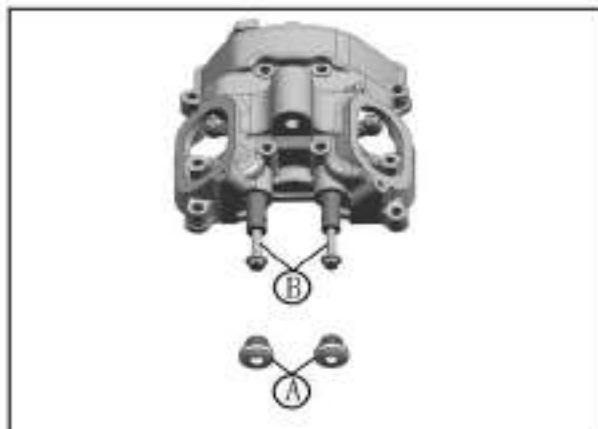

Rocker Arm

- When checking the rocker arm, check the inner diameter of the valve rocker arm and wear of the camshaft contact surface.
- **Rocker Arm I.D. :** .000~12.018mm

Tool: Dial Calipers

Assembly

Note: Intake rocker arm shaft A has oil holes.

- Apply engine oil to rocker arms and shafts;
- Install rocker arms and tighten rocker arm shaft to the specified torque:

Rocker Arm Shaft Bolt: 28N.m

Cylinder Had

Disassembly

- Remove intake pipe
- Remove water temperature sensor ① and thermostat cover ②

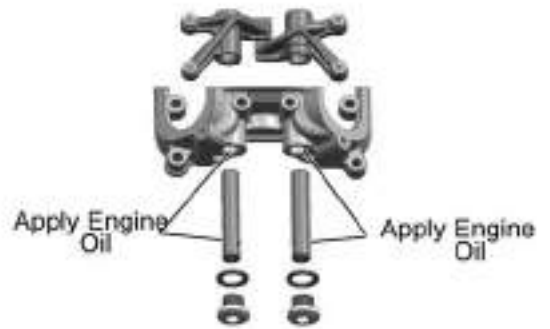
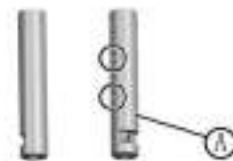
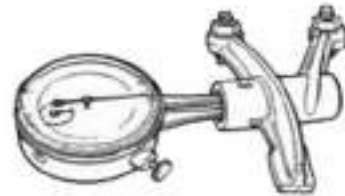

- Remove thermostat



- Compress the valve spring and remove valve cotter with tweezers.

**Tools: Valve Spring Compressor
Tweezers**

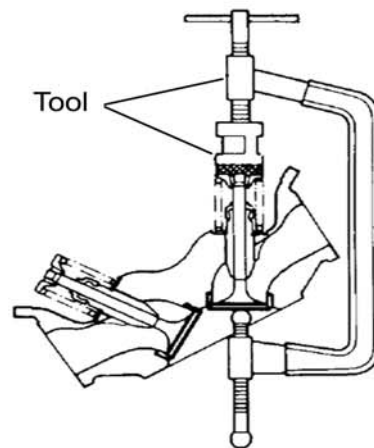

- Remove valve spring upper seat and valve spring
- Remove valve from the other side.



- Remove valve stem seal ring and valve lower seat.



Cylinder Head Distortion

Clean off carbon deposit from combustion chamber;
Check the gasket surface of the cylinder head for distortion with a straightedge and thickness gauge. Take clearance readings from several places. If any clearance reading is out of the service limit, replace with a new cylinder head.

Cylinder Head Distortion Service Limit: 0.05mm

Tool: Thickness Gauge

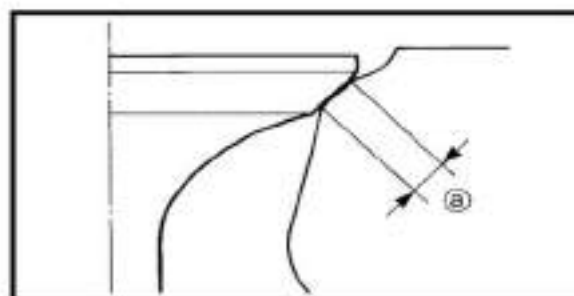
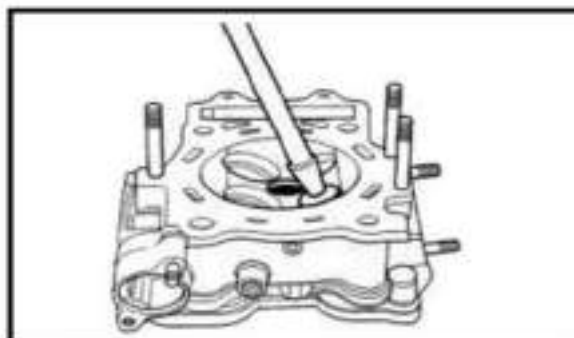
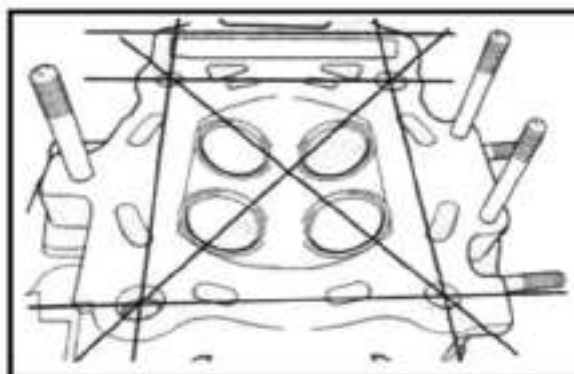

Valve Seat Width

- Coat the valve seat with color uniformly. Fit the valve and tap the coated seat with the valve face in a rotating manner. To get a clear impression of the seating contact, use a valve lapper to hold the valve head.
- The ring-like dye impression on the valve face should be continuous, without any break. The width of the dye ring, which is the visualized seat width, should be within the following range:

Valve Seat Width: 0.9-1.1mm

Tool: Valve Lapper

Valve Stem and Valve Guide

- Lift the valve about 10mm from valve seat. Check the valve stem deflection in the directions of X and Y perpendicular to each other, with a dial gauge. If the deflection measured is out of the limit, replace either the valve or the valve guide. (If the valve stem is worn to the limit and the clearance is found to be in excess of the limit, replace the valve. If the valve stem is within the limit, replace the valve guide. Double check the clearance after replacing the valve stem or the guide).

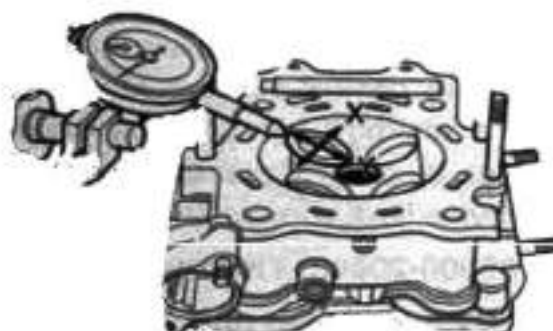
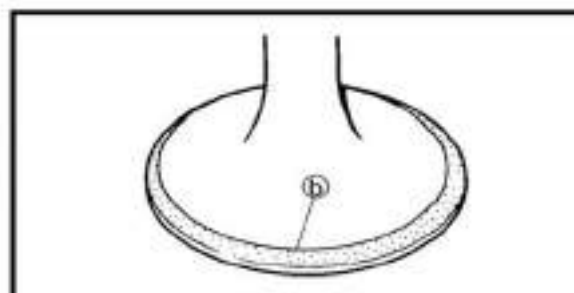

Valve Stem Deflection (IN & EX): 0.35mm

Tool: Micrometer

Magnetic Stand

Valve Stem O.D

- Measure valve stem O.D with a micrometer

Service Limit

IN: 4.975-4.990mm

EX: 4.955-4.970mm

Tool: Micrometer (0-25mm)



Valve Stem Run-out

- Support valve stem with V block as illustrated on the right. Check the run-out with a dial gauge.

Service Limit: 0.05mm

Tool: Magnetism Stand

Dial Gauge (1/100)

V block



Valve Head Radial Run-out

- Measure the valve head radial run-out as illustrated on the right.

Valve head Radial Run-out out of range: → Replace

Service Limit: 0.03mm

Tool: Dial Gauge (1/100)

Magnetic Stand

V Block



Valve Face Wear

- Check each valve face for wear or damage. Replace valve with a new one if it is found to have abnormal wear. Measure valve head thickness T.

Valve head thickness T out of range: → Replace

Service Limit: 0.5mm

Tool: Vernier Caliper

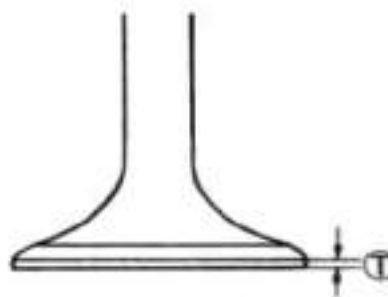

Valve Stem End

- Check valve stem end for pitting or wear. In case of any pitting or wear, resurface the valve stem end. If the length T is less than service limit, replace valve with a new one.

Valve Stem End Length

Service Limit: 2.1mm

Tool: Vernier Caliper

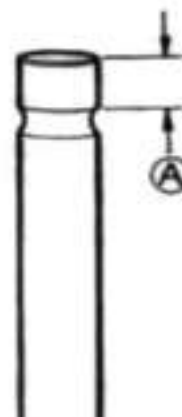

Valve Spring

- Valve Spring keeps valve and valve seat tight. Weakened spring results in reduced engine power output and chattering noise from valve mechanism.

- Measure the spring free length.
Spring free length out of range: → Replace

Service Limit: 38.8mm

Tool: Vernier Caliper.

- Measure the force to compress the spring to the specified length.

Valve spring tension out of range: → Replace

Service Limit: (IN/EX)

182N-210N/31.5mm

Tool: Spring Scale.

- Measure valve spring incline.

Spring incline out of range: → Replace

Valve Spring Incline Limit: 2.5°/1.7mm

Assembly of Cylinder Head

- Install each valve spring seat;
- Apply moly oil to valve stem seal and fit into position.

Material: Moly oil

Note: Do not reuse the valve stem seal.

- Insert the valves, with stems coated with moly oil all around.

Note: When inserting the valve, be careful not to damage the lip of the stem seal.

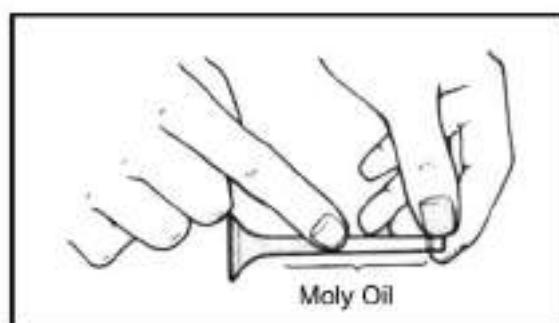
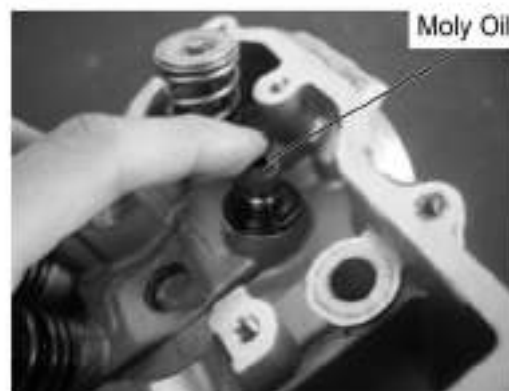
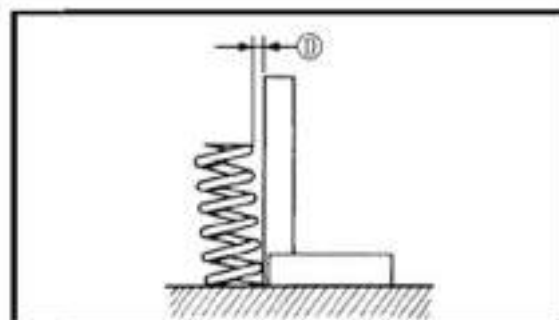
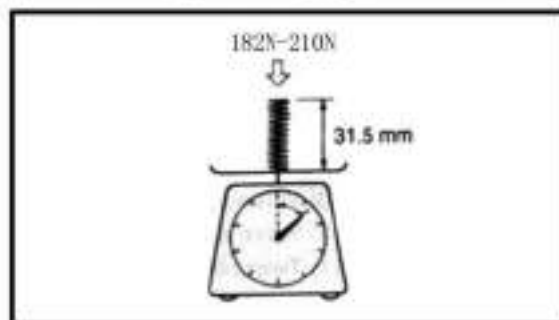
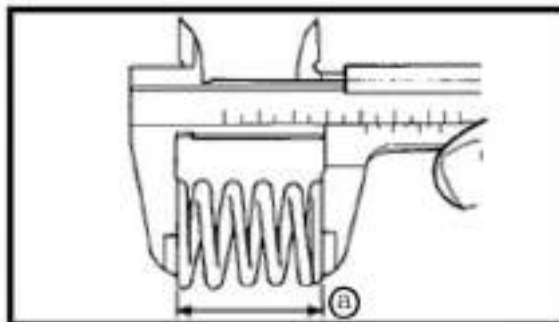

- Install valve spring with small-pitch end “b” facing cylinder head. Big-pitch end “a” is marked.

- Put on the valve spring retainer. Use the valve spring compressor to press down the spring. Fit the two cotter halves to the stem end and release compressor to allow the cotter ① to wedge in between seat and stem. Make sure that the rounded lip ② of the cotter fits into the groove ③ in the stem end.

**Tool: Valve Spring Compressor
Tweezers**

NOTE: Knock the valve end with rubber hammer. Make sure valve cotter is fit into groove.

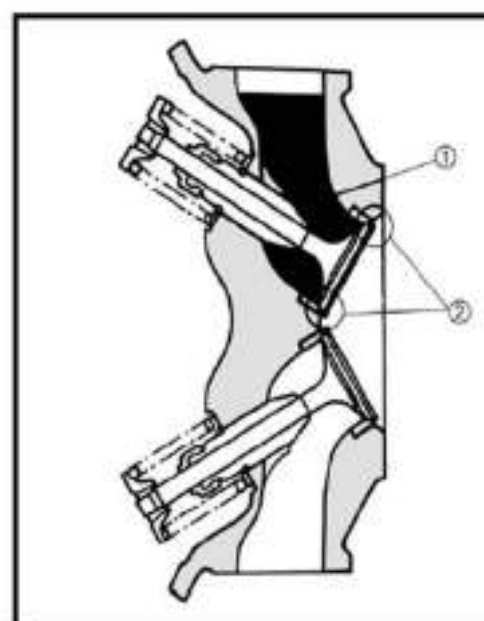
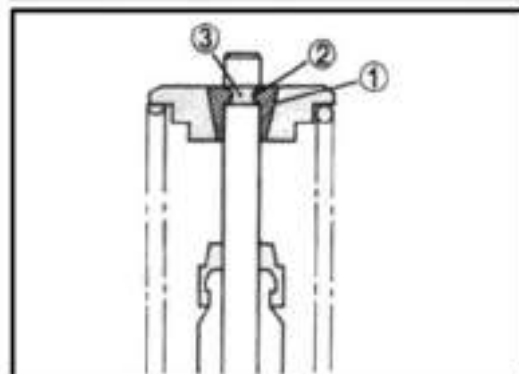
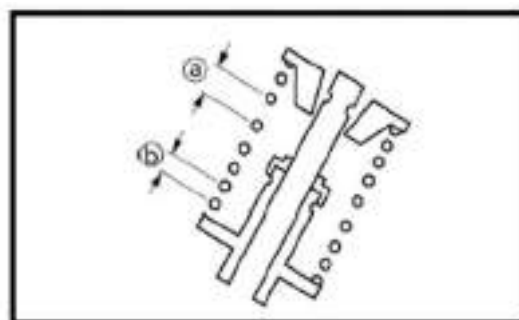

- Check the sealing effectiveness of cylinder head. Dip clean solution into valve IN/EX ① and check for any leakage of valve seat ② after a few minutes.

- Install thermostat



- Install thermostat cover

- Install water temperature sensor, apply thread locker to the thread part, tighten it to the specified torque.

Water temperature sensor

Tightening torque: 10 N·m



Apply Thread Locker

Water Temperature Sensor

- Install intake pipe, apply lubricant to O-ring.

Camshaft

Check camshaft for wear and run-out of cams and journals if the engine produces abnormal noise or vibration or lacks power output. Any of these symptoms could be caused by wear of camshaft.



Apply Lubricant Grease

Note: Do not try to disassemble the camshaft/automatic decompression assembly. It is not serviceable.

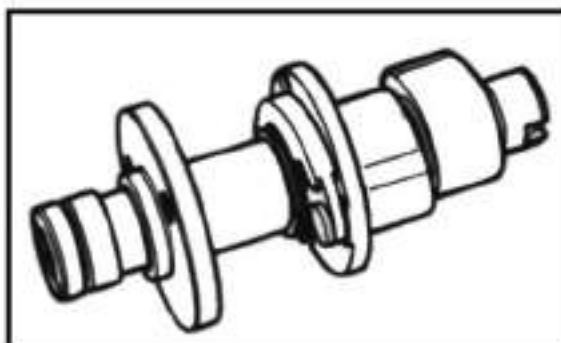

Automatic Decompression

- Move the automatic decompression weight with hand and check if it is operating smoothly. If it is not working smoothly, replace with a new camshaft/automatic decompression assembly.

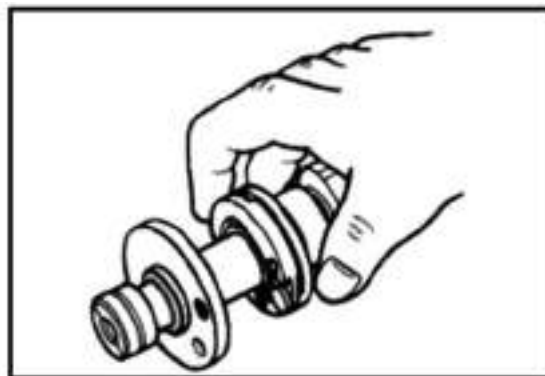

Cam Wear

Worn cams can often cause mistimed valve operation resulting in reduced power output. The limit of cam wear is specified for both IN and EX cams in terms of cam height "a". Measure with a micrometer the cam height.

Cam height out of range: → Replace

Cam height service limit:

IN: 33.130mm

EX: 33.200mm

Tool: micrometer (25-50mm)

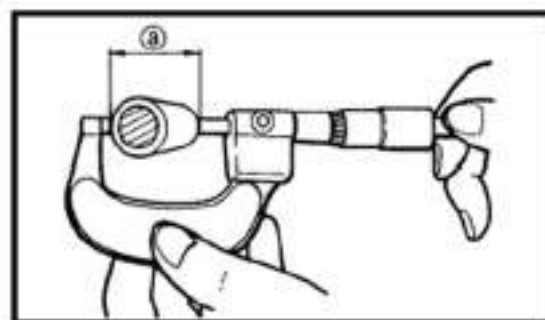

Camshaft Journal Wear

- Check whether each journal is worn to the limit by measuring camshaft journal oil clearance with the camshaft installed.

Camshaft journal oil clearance

Service limit: 0.15mm

Check according to the following steps:

- Clean off materials from cylinder head and cover;
- Install camshaft with plastic gauge;
- Install cylinder head cover and tighten bolts evenly and diagonally to the specified torque:

Tightening torque: 10 N·m

- Remove cylinder head cover, read the width of the compressed plastic gauge with envelop scale. The reading should be taken from the widest part.

Tool: Plastid Gauge

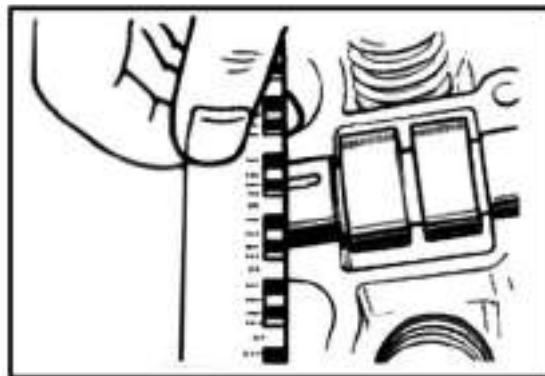

Note: Do not turn the camshaft with plastic gauge in place.

If the camshaft journal oil clearance exceeds the limit, measure the outer diameter of camshaft;

Replace either cylinder head set or the camshaft if the clearance is not correct.

Camshaft Journal O.D.

- Measure camshaft journal O.D. with a micrometer. If the O.D. is out of range, replace camshaft with a new one.

Camshaft journal O.D. service limit:

Sprocket end: 22.959 mm—21.980mm

Other end: 17.466mm—17.484mm

Tool: micrometer (0-25mm)

Camshaft Run-out

- Measure the run-out with a micrometer. Replace camshaft if the run-out is out of range.

Service limit: 0.10mm

Timing Sprocket and Chain

- Check timing sprocket and chain for wear or damage.
- Replace with new parts if abnormal wear or damage is found.

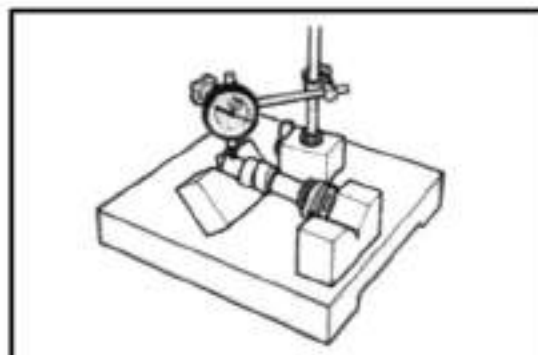
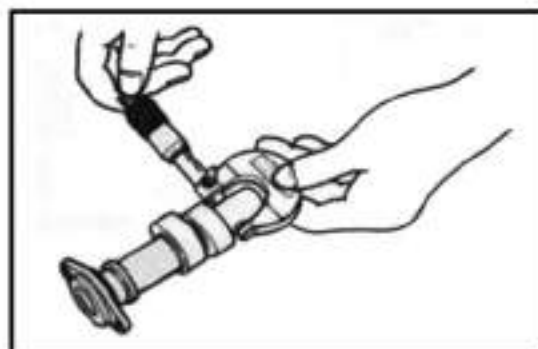

Tensioner and Chain Guide

- Check contact surface of tensioner and chain guide for wear and damage.
- Replace with new parts if abnormal wear or damage is found.

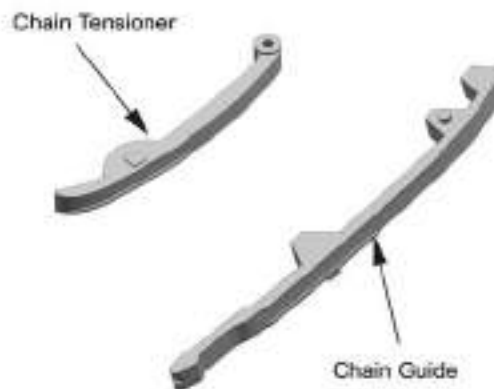

**Chain Tensioner
Inspection**

- Check tensioner for any damage or poor function.

Damage, poor function: → Replace

- Insert screw driver into the slotted end of adjusting screw, turn it clockwise to loosen the tension and release the screwdriver.
- Check the push rod movement. If the push rod is stuck or there is a failure with spring mechanism, replace the chain tensioner with a new one.



Cylinder

Cylinder Distortion

- Check the gasket face of cylinder for distortion with a straightedge and thickness gauge and take clearance readings at 7 points as illustrated. If the largest reading at any of the 7 points of the straightedge is out of the range, replace the cylinder.

Cylinder Distortion Service Limit: 0.05mm

Tool: Straightedge

Thickness Gauge

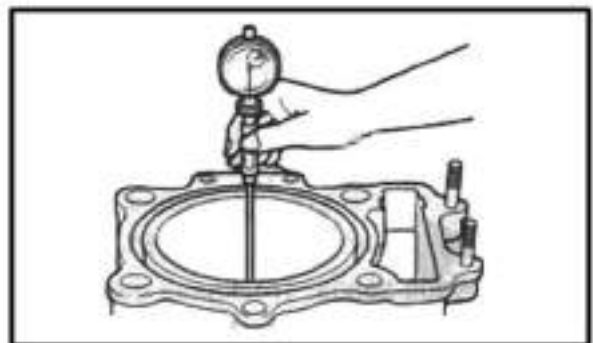
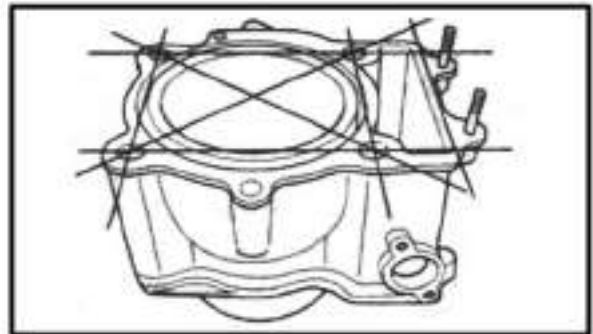

Cylinder Bore

- Check cylinder wall for scratches, nicks or other damage. Replace with a new one if any.
- Measure cylinder bore diameter at three points of upper, middle and lower.

Standard Cylinder Bore: 87.500-87.522mm

Tool: Cylinder Gauge Set

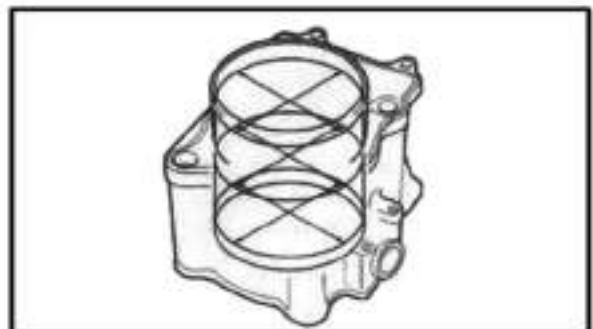

Piston

Piston Diameter

- Use a micrometer to measure the diameter at the point 10mm above the piston end, as illustrated on the right. If the measurement is less than the limit, replace the piston

Standard: 87.460-87.480mm

Limit: 87.380mm

Tool: Micrometer (75-100mm)

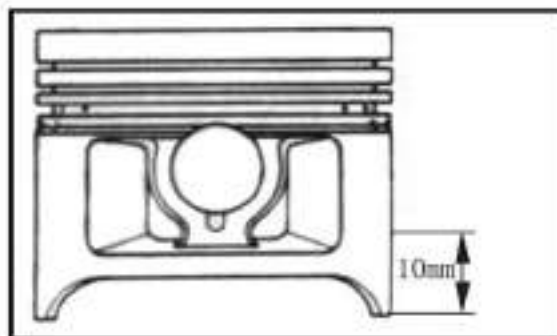

- Calculate the piston to cylinder clearance according to the above measurement.
- If the clearance is more than 0.15mm, replace the cylinder or piston, or both.

Piston Ring to Groove Clearance

- Use a thickness gauge to measure the side clearance of top¹ ring and 2nd ring.
- If the clearance exceeds the limit, replace both piston and piston rings.

Service Limit:

Top ring: 0.18mm

2nd ring: 0.15mm

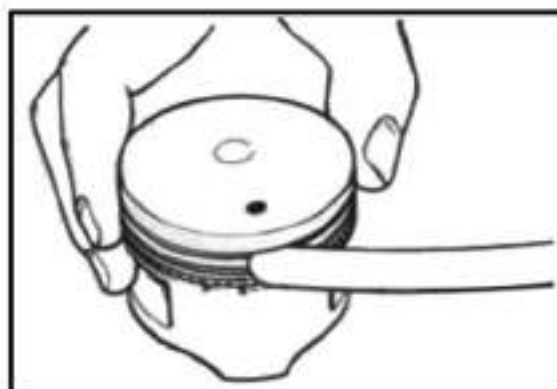
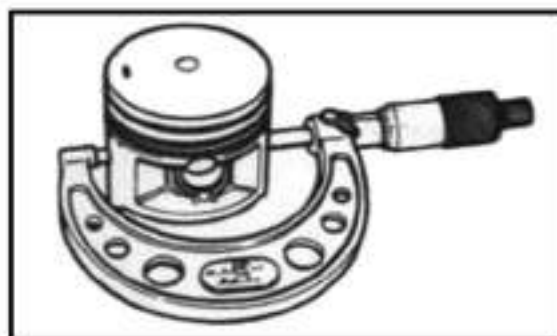

Standard width of piston ring groove

Top ring: 1.03-1.05mm

2nd ring: 1.22-1.24mm

Oil ring: 2.51-2.53mm

Standard thickness of piston ring

Top ring: 0.970-0.990mm

2nd ring: 1.170-1.190mm

Tools: Thickness gauge

Micrometer (0-25mm)

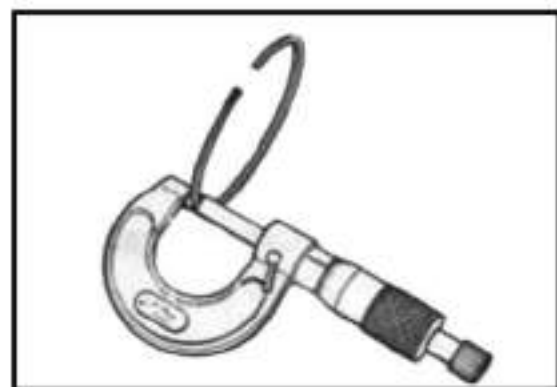

Piston Ring Free End Gap and End Gap

- Before installing piston rings, use vernier caliper to measure the free end gap of each ring, and then fit ring into the cylinder.
- Use thickness gauge to measure each ring end gap, if any ring has an excess end gap, replace the piston ring.



Piston ring free end gap limit:

Top ring: 8.9mm

2nd ring: 9.5mm

Piston ring end gap limit:

Top Ring: 0.60mm

2nd ring: 0.60mm

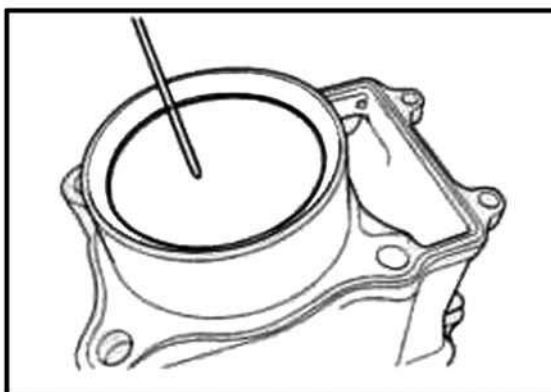

Tool: Vernier caliper

Thickness gauge

Piston Pin and Pin Bore

- Use a bore gauge to measure the inner diameter of piston pin bore.
- Use micrometer to measure outer diameter of piston pin.
- If out of limit, replace both piston and piston pin.

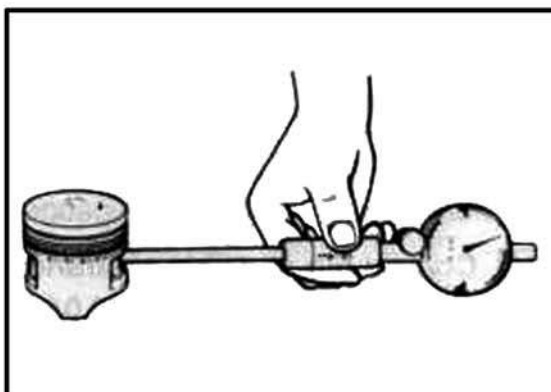

Piston pin bore limit: 23.030mm

- Use micrometer to measure piston pin outer diameter at three points

Piston pin outer diameter limit: 22.980mm

Tools: Bore gauge (18-35mm)

Micrometer (0-25mm)

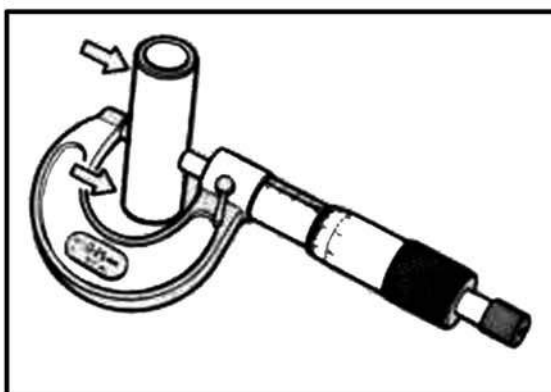

Connecting Rod/Crankshaft

Connecting rod small end I.D.

- Use a dial gauge to measure the I.D. of connecting rod small end. If the measurement exceeds the limit, replace the connecting rod.

Connecting rod small end I.D. : 23.040mm

Tool: Dial Gauge (18-35mm)

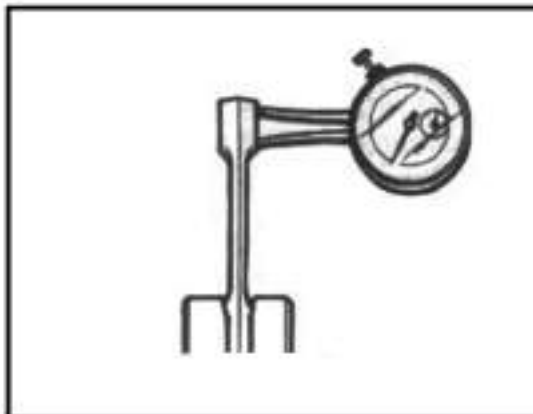

Connecting Rod Deflection

- Check the movement of the small end of the rod and inspect the wear of the small end. This method is also applicable to check and inspection of big end.

Connecting Rod Deflection: 3.0mm

Tools: Dial Gauge

Magnetic stand

V-block

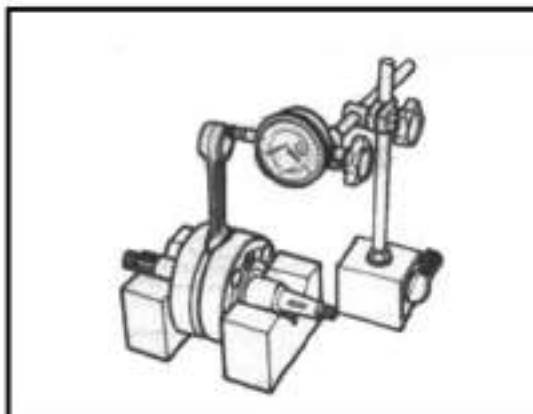

Connecting Rod Big End Side Clearance

- Push the big end to one side, and use thickness gauge to measure the other side clearance.
- If out of limit, replace with a new crankshaft.

Connecting Rod big end side clearance: 1.0mm

Tool: Thickness Gauge

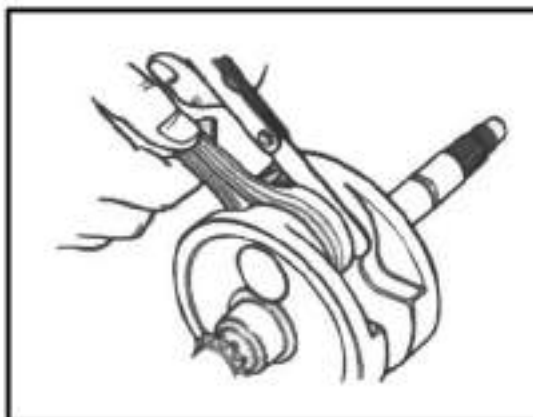

Crankshaft Run-out

- Support crankshaft with "V" blocks as illustrated. Put the dial gauge, slowly turn the crankshaft and measure run-out with a dial gauge.
- If the run-out exceeds the limit, correct or replace the crankshaft.

Run out limit: 0.08mm

Tools: dial gauge

Magnetic stand

V-block

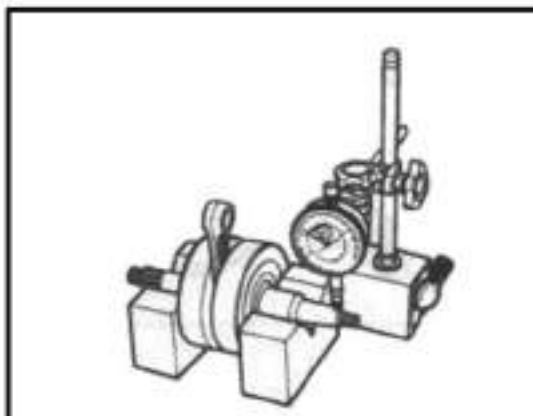

Clutch

Clutch Shoes

- Check clutch for chipping, scrape, uneven wear or heat discoloration. At the same time check depth of the grooves of clutch shoes. If any of the clutch shoes has no groove, replace the clutch.

Note: clutch should be replaced as a set.

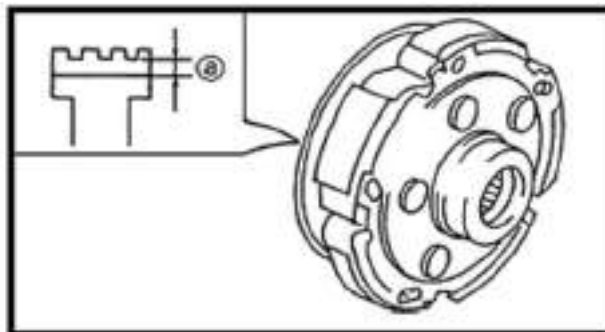

Clutch Wheel

Check the inner clutch wheel ① for scratches, scuffs or blue discoloration or uneven wear. If any damage is found, replace the clutch wheel with a new one.

- Check oil seal lip for wear or damage.

Wear or Damage: →Replace

- Use special tool to remove oil seal

Tool: Oil seal remover

- Use special tool to assemble oil seal

Tool: Oil seal installer set

- Check the turning of bearing.

Abnormal damage: →Replace

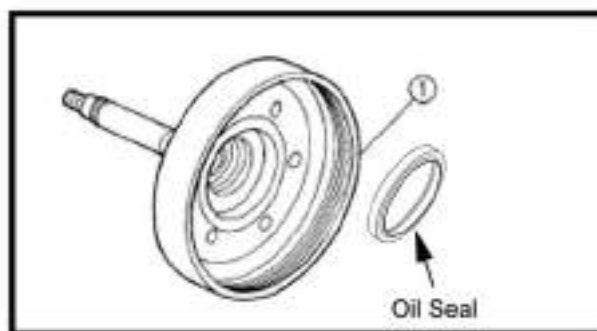

Assembly

- Apply lubricant grease to oil seal when assembling.

Primary and Secondary Sheave

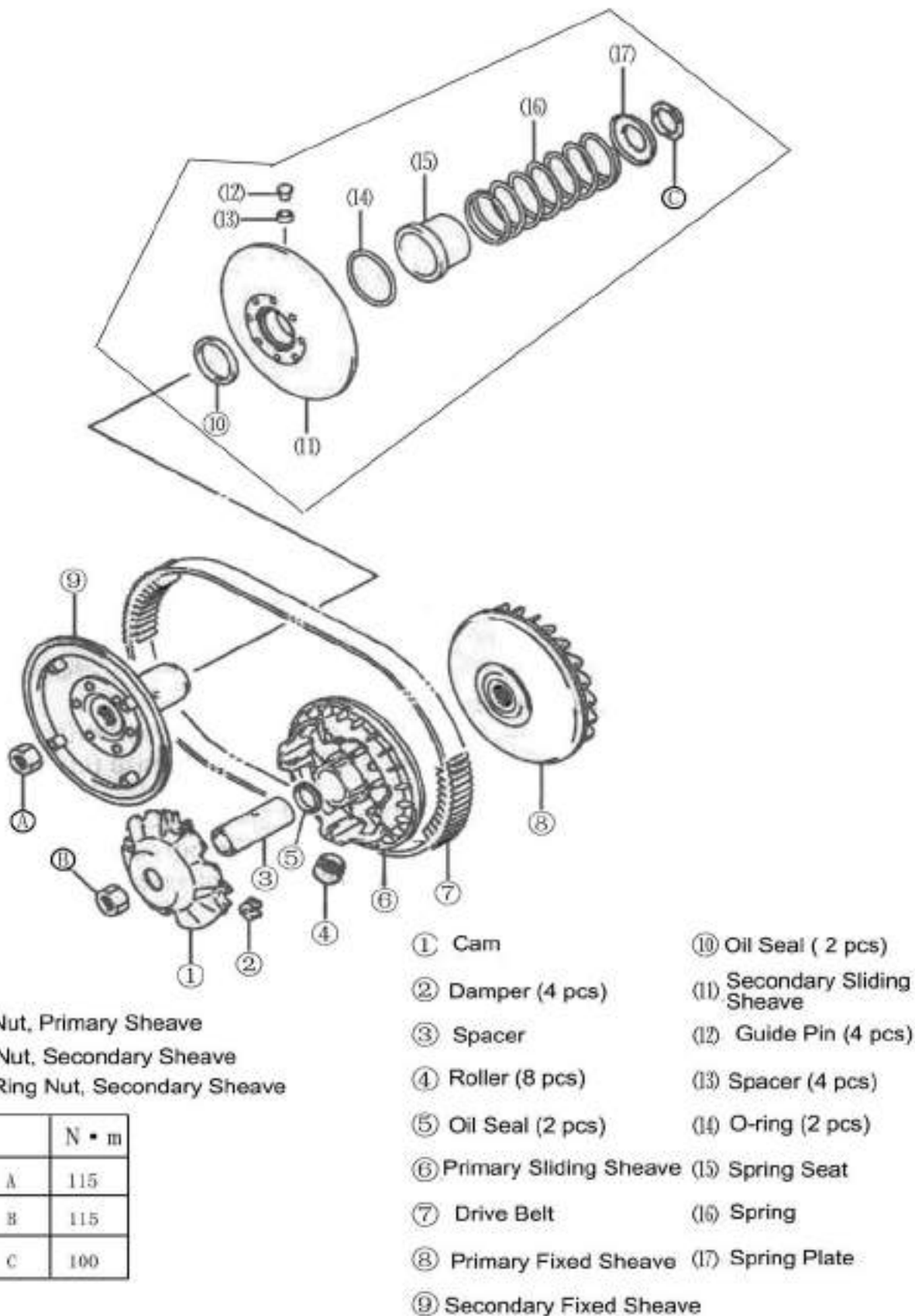

Primary Sliding Sheave

Disassembly

- Remove spacer
- Remove Cam ① and Roller ②



Roller

- Check each roller and sliding face for wear and damage.

Wear and damage: →Replace

Note: rollers should be replaced as a set.



Oil Seal

- Check oil seal lip for wear and damage.

Wear and damage: →Replace



- Remove the oil seal



Primary Sliding Sheave and Fixed Sheave

- Check the drive face for any abnormal conditions such as damage or stepped wearing.

Damage or wearing: → **Replace**



- Install oil seal with special tool.

Tool: Bearing install set

Assembly

Reverse the removal procedure of primary sliding and fixed sheave for installation.

Pay attention to the following:

- Apply grease to inner bore and oil seal lip.

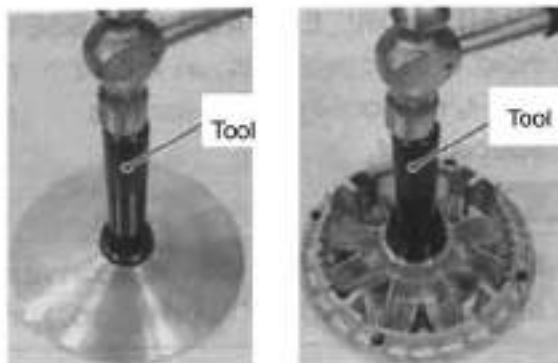

Note:

- Wipe off any excessive grease thoroughly.
- Take care not to attach any lubricant grease to contact surface of drive belt.

Material: Lubricant grease

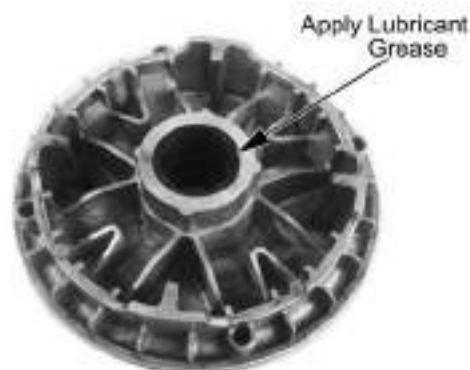

- Position 8 rollers ① on the primary sliding sheave
- Install 4 dampers ② to cam ③
- Install cam to primary sliding sheave.

Notes:

When inserting the spacer, press down the cam so that the rollers will not come out of position.

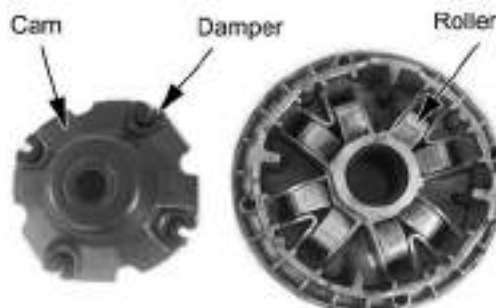

Install spacer

Secondary Sheave

Disassembly

- Use special tool and holder to hold the secondary sheave. Remove secondary sheave nut with special tool.



Caution:

Do not remove the ring nut before attaching the clutch spring compressor.

Tool: Nut Wrench

Sheave Holder

- Attach special tool to the secondary sliding sheave and compress it by turning in the tool handle.



Note:

Make sure that spring end A is inserted into slot B of the tool handle.

- Remove ring nut.

Tool: Secondary sliding sheave spring compressor

Note:

Since a high spring force applies to the secondary sliding sheave, take special care that the secondary sliding sheave will not come off abruptly.

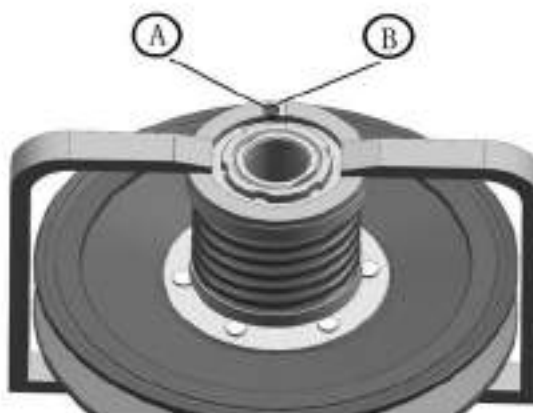

- Slowly loosen tool handle and remove the special tool.



- Remove spring ①
- Remove spring seat ②.



- Remove guide pin and spacer.

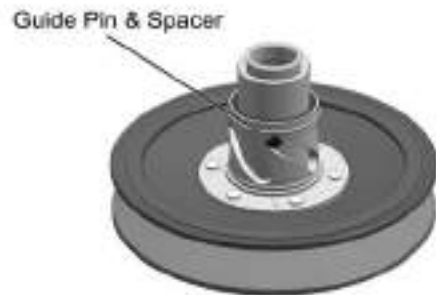

- Remove secondary sliding sheave ③



O-ring and Oil Seal

Check the O-ring and oil seal for wear and damage.

Wear and Damage: → **Replace**



- Remove Oil Seal



- Install oil seal with special tool.

Tool: Bearing install set

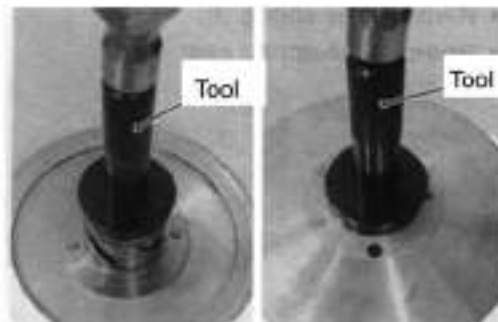

Secondary Sheave Spring

- Use vernier caliper to check the spring free length. If the length is shorter than the service limit, replace with a new one.

Service Limit: 145.4mm

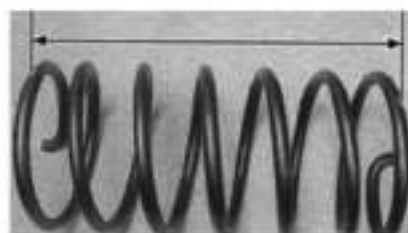

Secondary Sliding and Fixed Sheave

- Check drive face for any abnormal condition such as stepped wear or damage.

Wear or damage: → Replace



Assembly

- Install a new O-ring
- Apply lubricant grease to O-ring, oil seal lip and guide pin groove.

Material: lubricant grease



- Install guide pin and spacer ①

Note: To avoid damage to the oil seal lip during assembly, slide the lip with a 0.1mm steel sheet as guide.

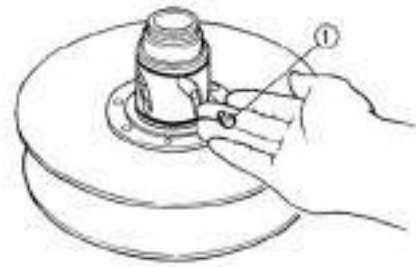

- Install spring seat. Align hole A with hole B.

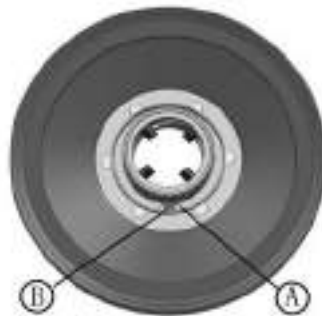

- Install spring and spring plate. Insert spring end into the hole.



- Compress spring with special tool.
- Align the secondary sheave end with spring plate hole.

Tool: Secondary sheave spring compressor



- Tighten ring nut temporarily.
- Remove the special tool from secondary sheave.



- Tighten the ring nut with special tool to the specified torque.

Ring Nut Tightening Torque: 100N·m

Tool: Ring nut wrench

Sheave Holder



Drive belt

- Check belt for any greasy substance.
- Check contact surface of belt for any cracks and damage.
- Check belt width with vernier caliper.

Damage, width out of range: →Replace

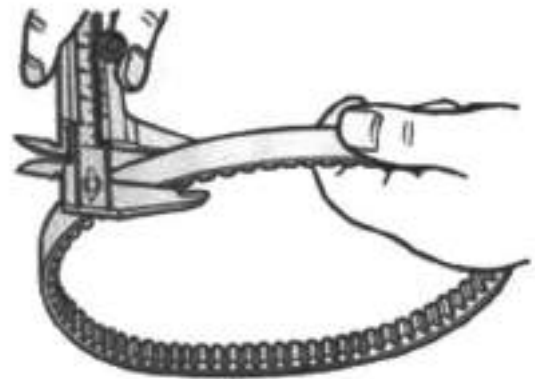

Belt width service limit: 33.5mm

Tool: vernier caliper

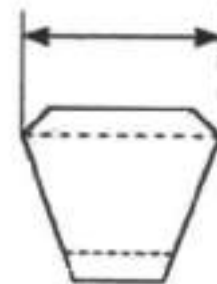

Caution:

If belt surface is stained with grease or oil, degrease the belt thoroughly.

Transmission

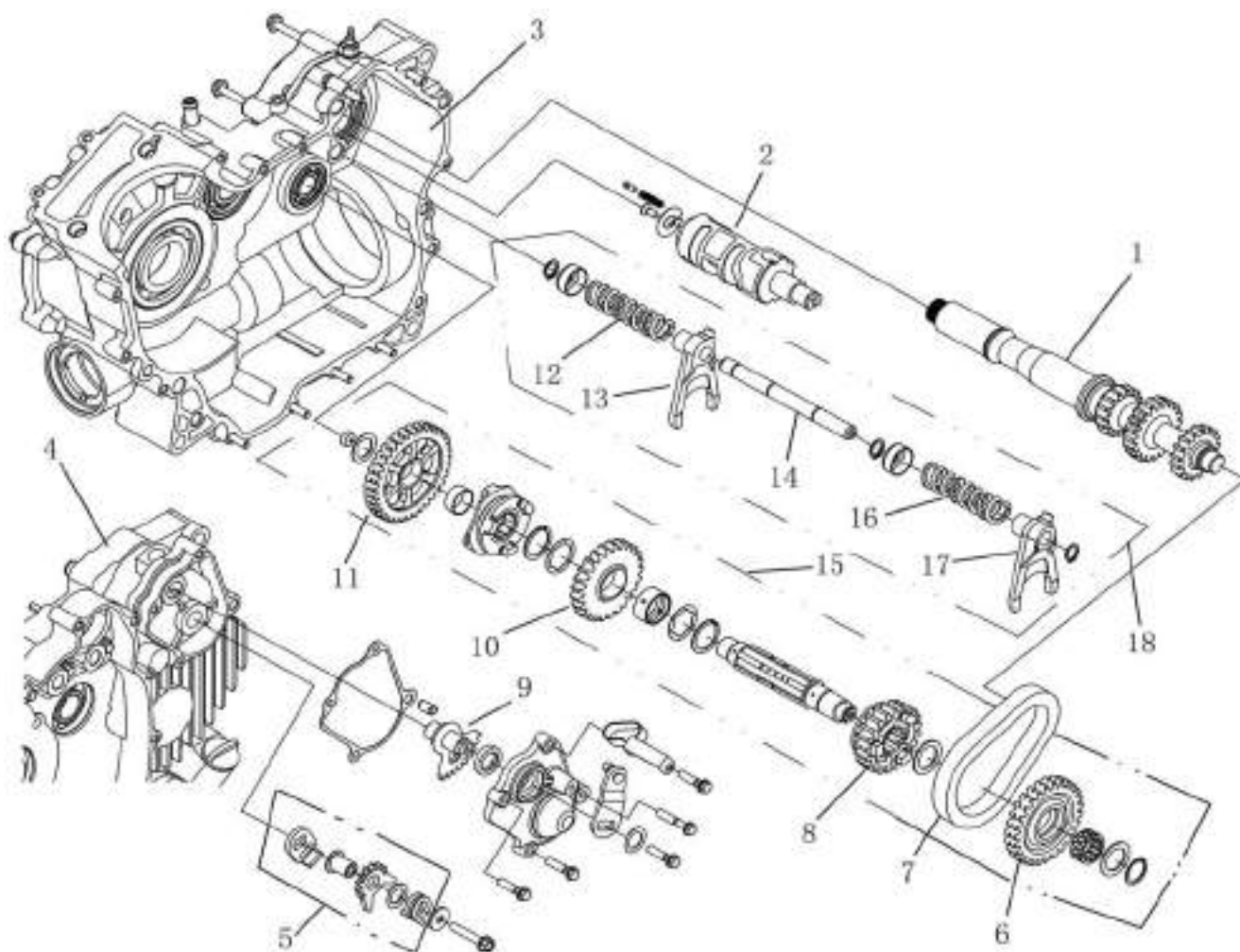

No.	Description	Qty	No.	Description	Qty.
1	MAIN SHAFT. GEARSHIFT	1	10	DRIVEN GEAR, HIGH RANGE	1
2	SHIFT CAM	1	11	DRIVEN GEAR, LOW RANGE	1
3	RIGHT CRANKCASE	1	12	SPRING, SHIFT FORK	1
4	LEFT CRANKCASE	1	13	RIGHT SHIFT FORK	1
5	DRIVEN SECTOR GEAR	1	14	GUIDE BAR	1
6	SPROCKET, REVERSE GEAR	1	15	DRIVEN SHAFT	1
7	CHAIN, REVERSE GEAR	1	16	SPRING, SHIFT FORK	1
8	DRIVEN OUTPUT GEAR	1	17	LEFT SHIFT FORK	1
9	DRIVE SECTOR GEAR	1	18	SHIFT FORK ASSEMBLY	1

Inspection

- Check main shaft gear and sprocket surface for any damage or over wear.

Damage or over wear: → **Replace**

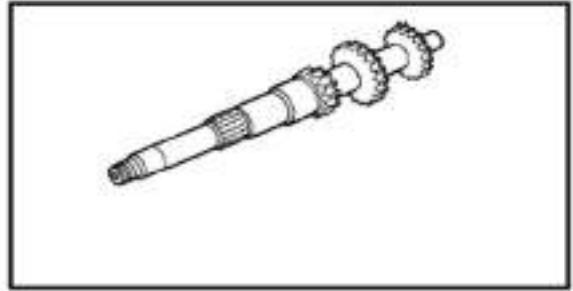

- Check reverse gear chain for any damage or over wear.

Damage or over wear: → **Replace**



- Disassemble driven shaft as illustrated.

- Check each gear surface for any damage or over wear.
- Check bearing and collar for any wear or damage..

Damage or over wear: → **Replace**



- Check the shift fork clearance with a thickness gauge in the groove of its gear.

Clearance exceeds the limit: → Replace

Shift fork to Groove clearance

Standard clearance :0.10-0.30mm

Service Limit :0. 50mm

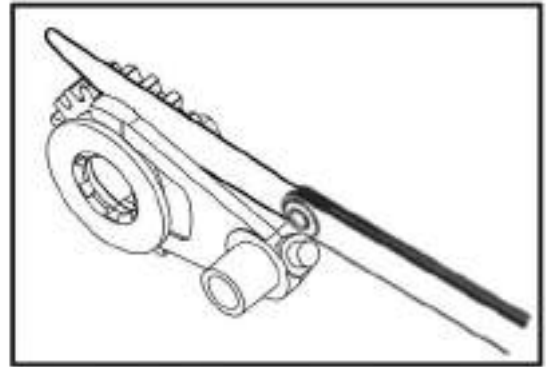

- Measure shift fork groove width with vernier caliper

Standard shift fork groove width: 6.05-6.15mm

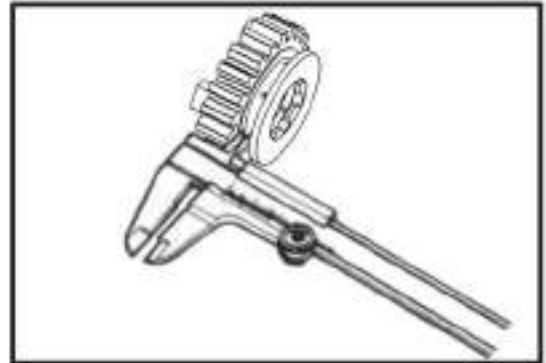

- Measure shift fork thickness with vernier calipers;

Standard fork thickness: 5.08-5.90mm

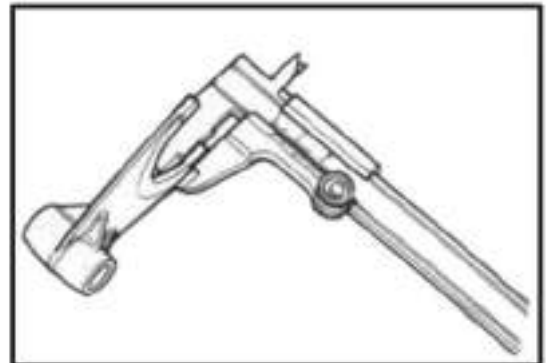

- Check shift fork ① and ② for damage or bend

Damage, bend: → Replace

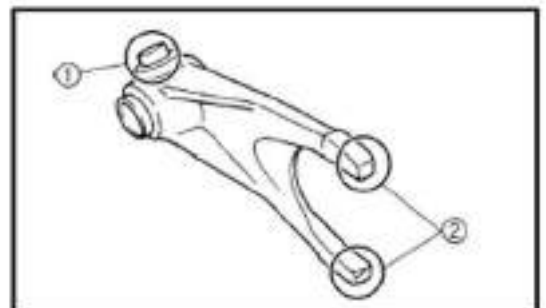

- Install shift fork to guide bar and move left and right. In case of any unsmooth moving, replace with a new one.

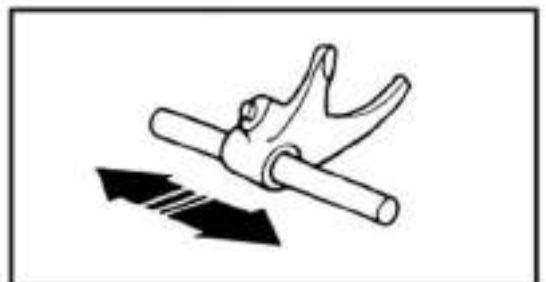

- Put the guide bar on a flat plate and roll it. In case of any bend, replace with a new one.

NOTE: DON NOT attempt to correct a bent guide bar.

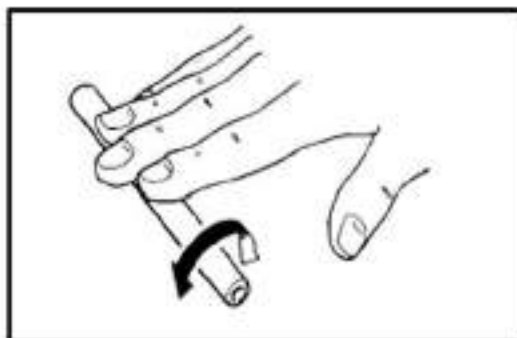

- Check shift fork spring for breakage, damage
Broken or damaged: → Replace

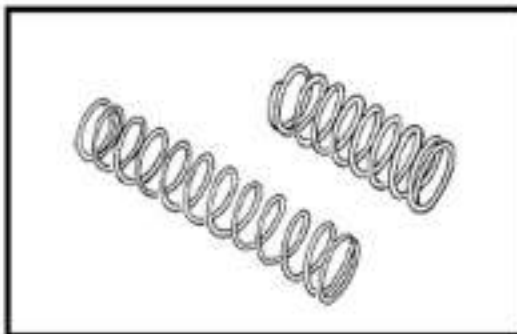

- Check shift cam groove for scratches, damage.
Scratch or damage: → Replace

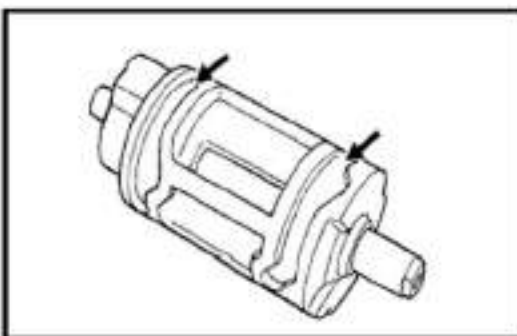

Assembly

Reverse the removal procedure for assembly. Pay attention to the following:

- Use new retainers. Pay attention to the direction of the retainers. Fit to the side where the thrust is as illustrated.
- Coat the gears and shafts with engine oil before assembly.

Note:

- Do not reuse the retainers
- Do not expand of the gap end of new retainers too wide when assembling.
- Make sure that all the retainers are properly fitted.

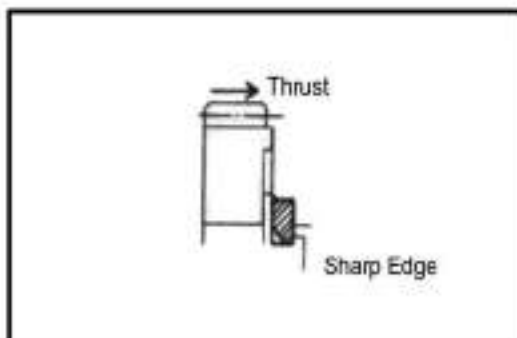

- When assembling the guide bar, take care not to assemble the two shift forks and springs in the opposite direction.

- | | |
|---------------------|------------------------------|
| 1. Guide bar | 2. Retainer |
| 3. Left shift fork | 4. Shift fork Spring (small) |
| 5. Right shift fork | 6. shift fork spring (big) |
| 7. Spring seat | |

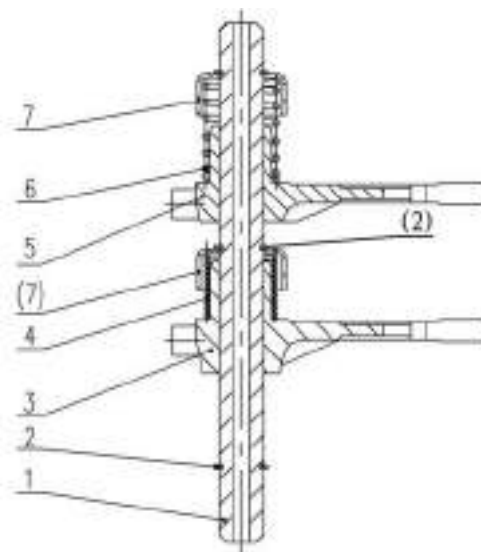

OIL PUMP

- Disassembly oil pump as illustrated:

1. Oil pump housing	2. Dowel pin
3. Oil pump shaft	4. Straight pin
5. Inner rotor, oil pump	6. Outer rotor, oil pump
7. Oil pump cover	

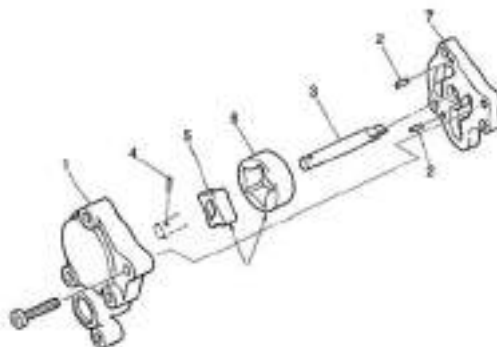

- Check oil pump housing and cover for cracks and damage.

Crack or damage: → Replace

- Measure top clearance “a” between inner and outer rotors and side clearance “b” between outer rotor and oil pump housing. If the clearance exceeds the limit, replace with new one.

Top Clearance: 0.03-0.10mm

Service Limit: 0.15mm

Side clearance: 0.03-0.10mm

Service Limit: 0.12mm

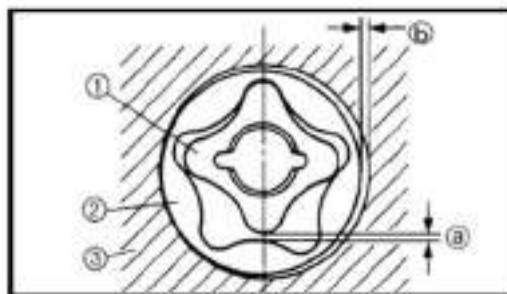
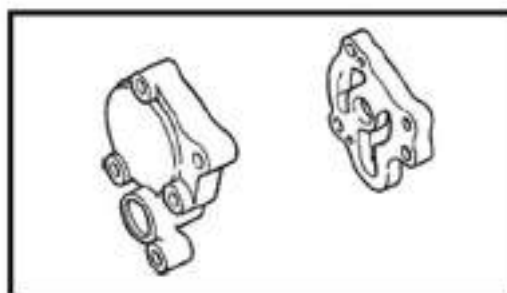

Oil strainer

- Check oil strainer ① and O-ring ② for damage

Damaged oil strainer: → Replace

- Clean the surface of oil strainer with engine oil

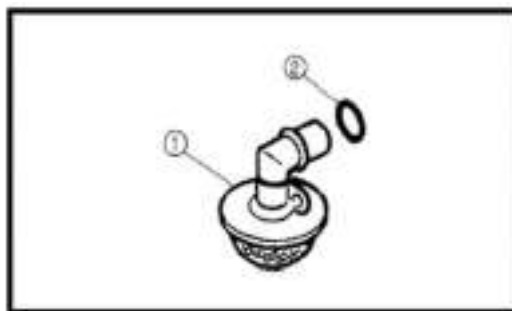

Relief Valve

- Check the valve body ①, valve ② and spring ③ O ring ④ for damage or wear.

Damage or wear: → Replace

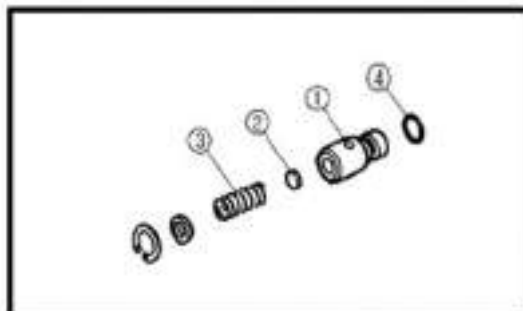

Drive Bevel Gear

- Use a clean rag to protect the drive bevel gear shaft, clamp it to the pliers.

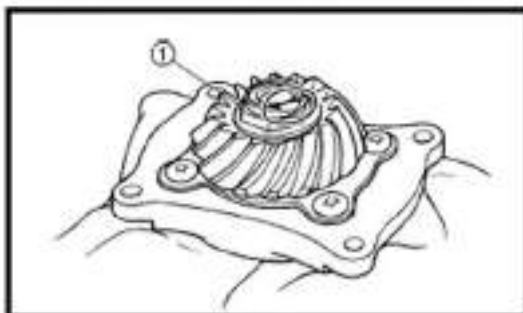

- Loosen drive bevel gear nut 3, remove the drive bevel gear 4 and adjust washer 5
- Check the drive bevel gear 4 and output driven gear 2 for rust, scratch, wear or damage. Replace if any.
- Check if the bearing 8 turns smoothly, replace with a new bearing if necessary.
- Adjust Washer 5 if any of right crankcase, drive bevel gear 4, or drive bevel gear cover 1 is replaced. Refer to bevel gear adjustment for details.
- Apply engine oil to bearing 8 when assembling and tighten nut 3 to the specified torque.

- | | |
|---------------------------|---------------------------|
| 1. Drive bevel gear cover | 5. Adjust washer |
| 2. Output driven gear | 6. Drive bevel gear shaft |
| 3. Drive bevel gear nut | 7. Bearing press |
| 4. Drive bevel gear | 8. Bearing |

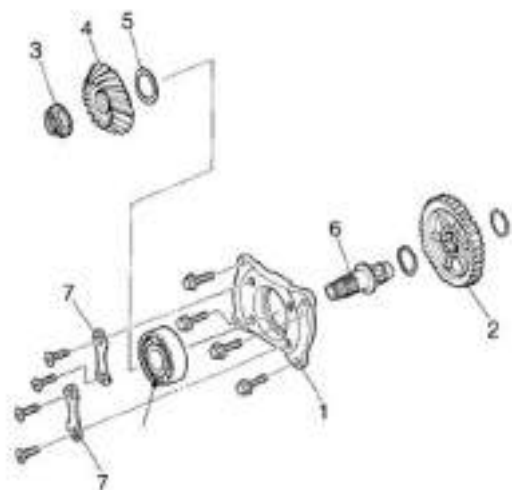

Drive bevel gear nut

Tightening torque: 145N.m

Front Output Shaft

- Check bearing 7 for smooth turning and abnormal wear. Check oil seal 5 for damage.

Wear or damage: → Replace

- Apply lubrication oil to bearing 7 and oil seal 5 lip before assembly.

- Apply thread locker to bearing limit nut 6 (left thread) and tighten to the specified torque.

Bearing limit nut Tightening torque: 80N.m

Tighten Nut 1 to the specified torque

Front output shaft nut tightening torque: 97N.m

Driven Bevel Gear

Remove nut 19, washer 18, coupler 17 and oil seal 16.

- Protect end thread of driven bevel gear with proper device ②. Fix bevel gear cover 14 and press out driven bevel gear.

- Place a clean rag ① under bevel gear cover. Remove bearing limit nut 10 with special tool ② and remove bearing.

- Check driven bevel gear 8 surface for scratches, wear. Scratch or wear: → Replace

- Check free turning of bearing 9 and 11. Replace with a new one if any abnormal is found.

- Use new oil seal 16 and O-ring 12 when assembling.

- Adjust washer 13 if any of right crankcase, driven bevel gear 8 or driven bevel gear cover 14 is replaced. Refer to bevel gear adjustment for details.

- Apply lubrication oil to bearing 9 and 11 and oil seal 16, O-ring. Apply thread locker to nut 10 and tighten to the specified torque.

Tightening torque :110N.m

Tool: driven bevel gear nut wrench

Driven bevel gear nut tightening torque:150N.m

Bevel Gear Washer Adjustment

- Adjust washer ① and ② when replacing crankcase and/or bevel gear and/or bevel gear cover,

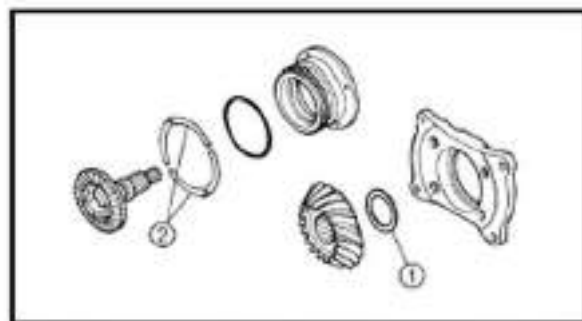
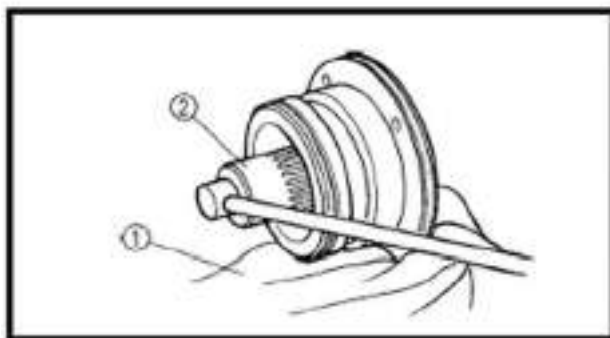
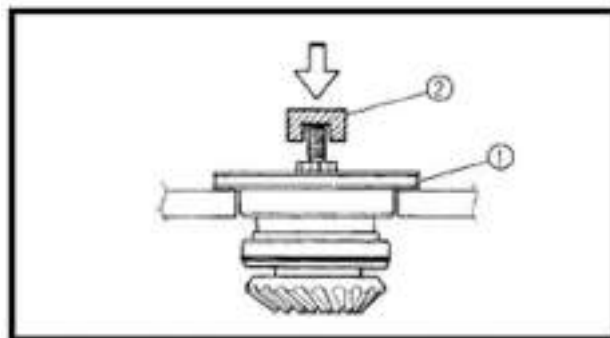
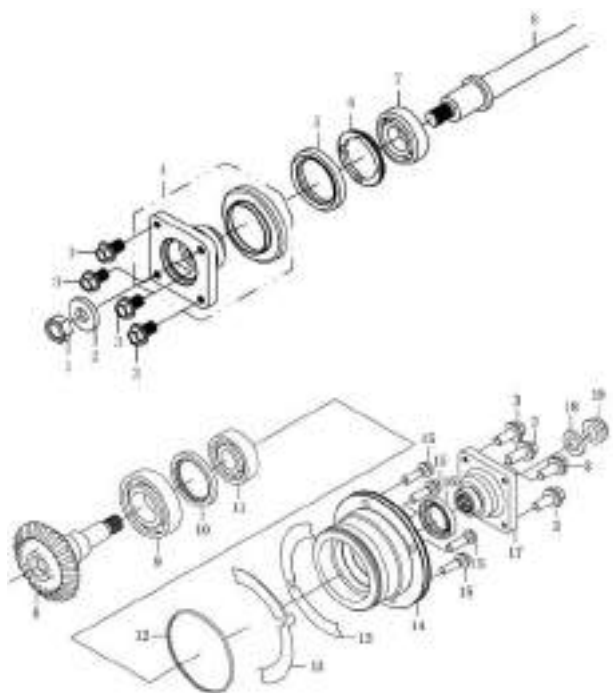

Bevel Gear

Note: Proper bevel gear engagement depends on that the gear backlash and tooth contact are within the proper range.

Bevel Gear Backlash

- Install drive and driven gears to the crankcase. Wrap a (-) screwdriver ③ with a rag ② and insert it into the speed sensor hole ① of left crankcase to fix the drive bevel gear.

- Install special tool ③ and micrometer ④.

Tool: Bevel gear side clearance dial gauge

Micrometer

a=46mm

- Turn the driven bevel gear in each direction and measure the backlash.

NOTE: Measure four points in the mutual vertical direction

- If the backlash is not within the specification, adjust the thickness of the driven bevel gear adjust washer. Re-check the backlash until the backlash is correct.

Bevel Gear Backlash: 0.1-0.2mm

Adjustment

Measured Backlash	Washer Thickness Adjustment
<0.1mm	Decrease washer thickness
0.1~0.2m	Correct
>0.2mm	Increase washer thickness

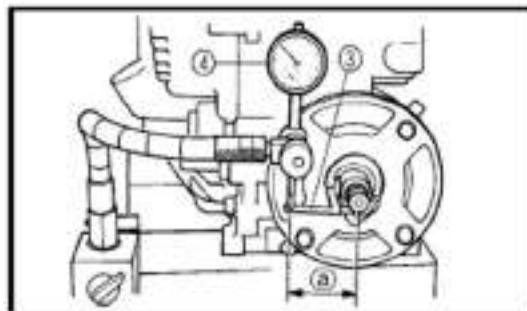
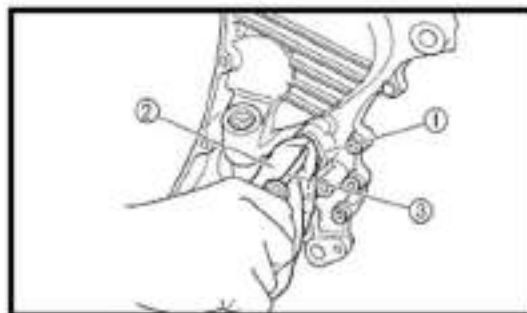

Tooth Contact

- After adjusting the backlash, check the tooth contact according to the following procedures:
 - Remove drive and driven bevel gear shafts from crankcase;
 - Clean and degrease every tooth of drive and driven bevel gear;
 - Coat the driven bevel gear with machinist's layout dye or paste;
 - Install drive and driven bevel gear;
 - Rotate the driven bevel gear several turns in both directions;
 - Remove drive and driven bevel gear shafts and check the coated teeth of the drive bevel gear;
 - Refer to the illustration on the right for tooth contact pattern ①, ② and ③
- ① Incorrect (contact at tooth top)
 ② Correct
 ③ Incorrect (contact at tooth bottom)
- If tooth contact is correct (Contact ②), continue the next procedure.
 - If tooth contact is not correct (② and ③), adjust the thickness of the washer of drive bevel gear. Repeat above steps to check tooth contact until it is correct.

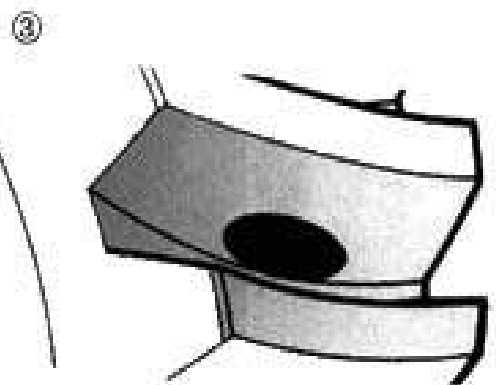
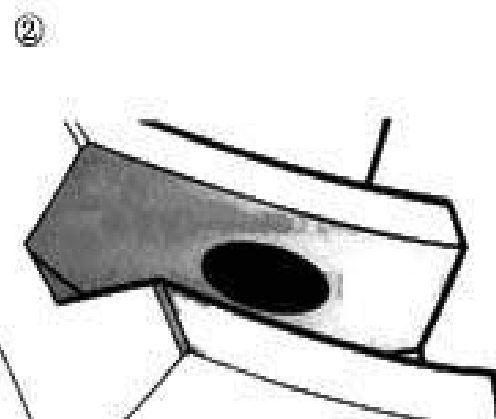
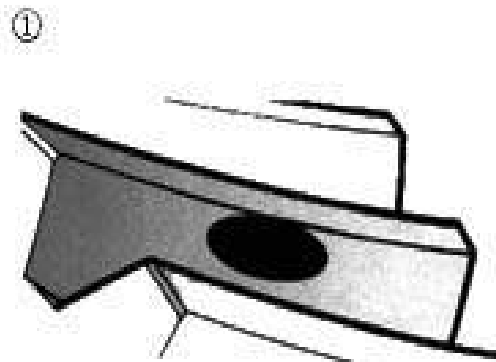

Adjustment

Tooth Contact	Washer Adjustment
Contact at tooth top ①	Increase Thickness
Contact at tooth bottom ③	Decrease Thickness

Note:

- After adjusting the tooth contact, the backlash must be checked again;
- If the backlash is adjusted but tooth contact is still out of specification, replace the drive and driven bevel gears;
- Both tooth contact and backlash should be within the required specification.

Balancer Shaft

- Remove the parts as illustrated on the right. Check each part for abnormal wear or damage.

Wear or damage: → Replace

- ① Balancer shaft gear
- ② Woodruff key
- ③ Balancer shaft
- ④ Balancer shaft sprocket
- ⑤ Washer
- ⑥ Bolt

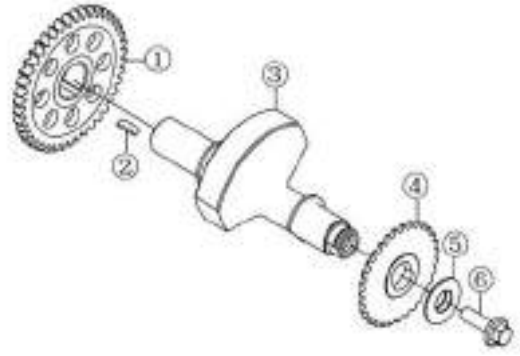

Magneto Rotor

- Remove starter clutch nut;



- Check starter clutch roller and holder for abnormal wear or damage.

Wear or damage: → Replace

- Install the starter clutch in the correct direction.

Note:

When install the starter clutch to the magneto rotor, make sure side “A” is in the right direction.

- Face arrow mark “B” to the engine side;
- Apply engine oil to starter clutch.
- Apply thread locker to bolt and tighten to the specified torque:

Tightening torque of starter clutch bolt: 26N.m

Material: Thread Locker

- Install the starter driven gear
- Make that the starter driven gear turns in the opposite direction of the arrow mark “B”. The gear cannot turn in the direction of the arrow.
- Check starter driven gear bearing. In case of anything unusual, replace the bearing.
- Remove starter driven gear bearing with special tool
- Install starter driven gear bearing with special tool.

Tool: Bearing Installer/Remover



Electric Starter Gear

- Check the gear surface for scrap or damage.

Scrape or Damage: → Replace

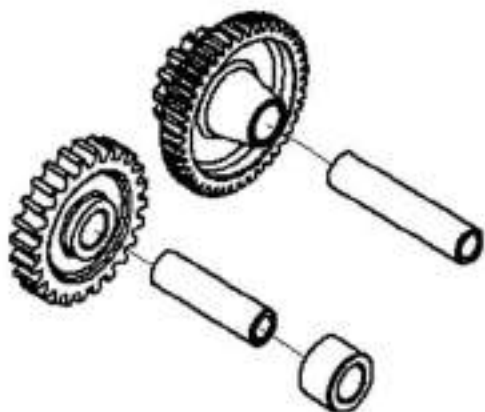

LEFT CRANKCASE COVER

- Check magneto stator coil 2, pickup coil 3 for damage,
- burn or short circuit, if any , replace with new one;
- Check bearing 4 for smooth turning. If it is stuck, replace with a new one;
- Check oil seal 5 for damage. Replace it if it's damaged;
- Apply thread locker to the bolt when assembling.
Tightening torque for magneto coil bolt: 10N.m
- Apply lubrication oil to bearing 4 and lubricant grease to lip of oil seal 5 when assembling.

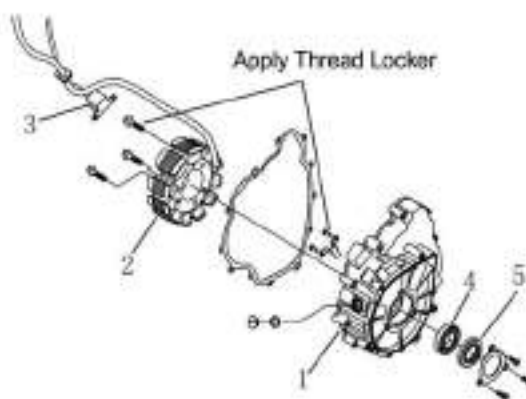

Recoil Starter

Disassembly

- 1— Recoil starter
- 2— Bolt
- 3— Washer
- 4— Starter pulley

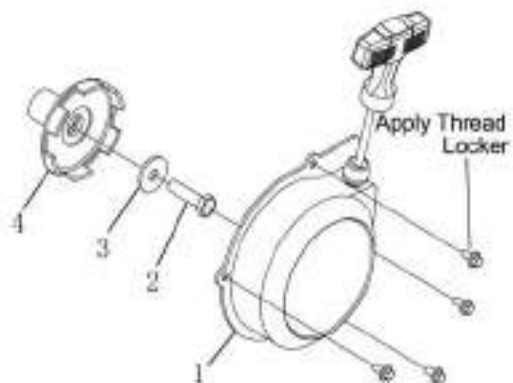

Inspection

Check sheave drum for burrs, cracks or rust. In case of any abnormal, replace.

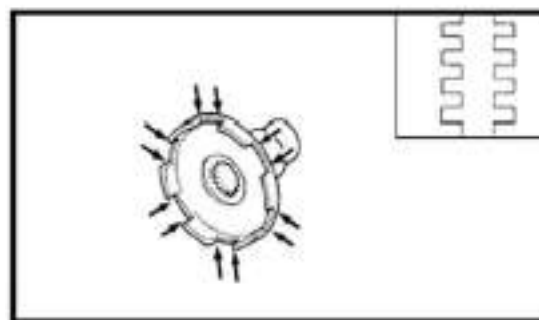

Recoil Starter

- If the recoil starter works normally, it's not necessary to disassemble it.

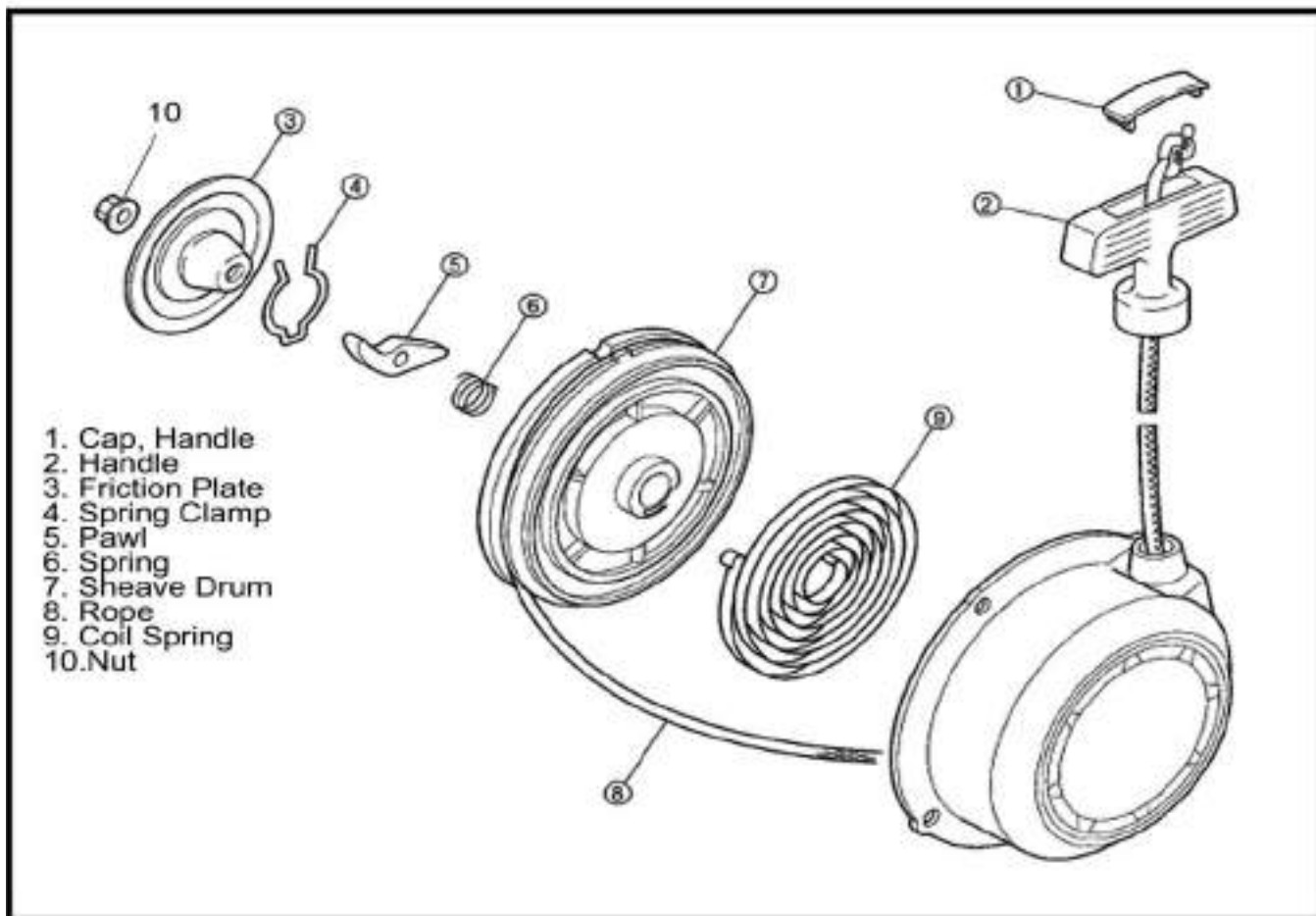

DISASSEMBLY

- Remove nut 10,
- Remove the parts from the starter housing.

WARNING !

The coil spring may quickly unwind and cause injury when the sheave drum is opened. Wear proper hand and eye protection beforehand.

Inspection

Check all the parts for damage.

Damage: →Replace

Assembly

- Reverse the removal procedure for installation and pay attention to the following:
- Install sheave drum①, rope②, coil spring③, damper④
- Wind the rope clockwise around the sheave drum three times and hook the rope at "a" of sheave drum.

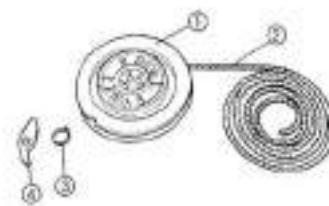

WARNING !:

The coil spring may quickly unwind and cause injury when the sheave drum is opened. Wear proper hand and eye protection beforehand.

- Install coil spring ① and sheave drum ②
- Apply lubricant grease to spring
- Hook coil spring end ③ to the starter housing, wind the coil spring clockwise.
- Hook the other end ⑤ of coil spring to hook part ④ of sheave drum.

Apply Lubricant Grease

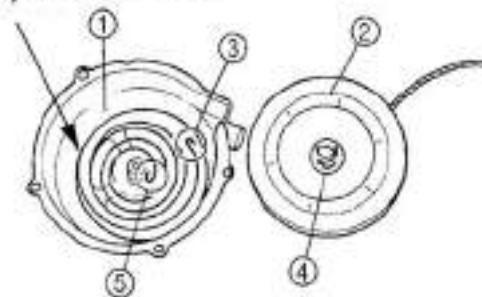

- Install spring clamp①, friction plate ② and bolt.
- Turn sheave drum three times for pretension of coil spring.

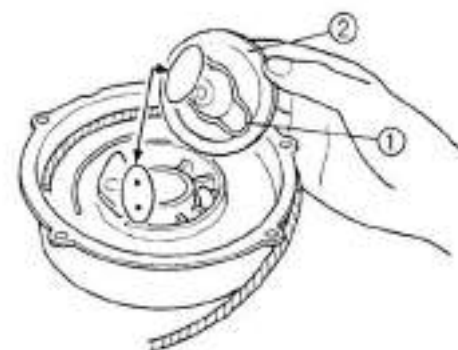

- Install handle① and handle cap②

- Tie a knot④ on handle and release knot ③

- Lead the rope through the hole of the starter housing and tie a knot ③ so that the rope would not be drawn back.

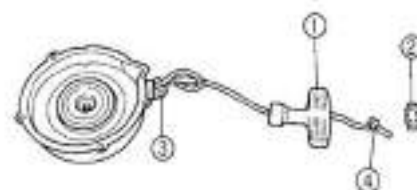

CVT Cover

- Remove screw 5, oil seal limiter 4. Remove oil seal 3 with special tool;
- Check bearing 2 for free turning. In case of any abnormal, remove with special tool and replace with a new bearing;
- Apply lubrication oil to outer ring of bearing and install bearing with special tool. Check bearing for smooth turning.
- Apply grease to bearing inner side;
- Apply grease to oil seal lip and install oil seal with special tool.

Note: Use a new oil seal.

- Install oil seal limiter and tighten screw after applying thread locker.

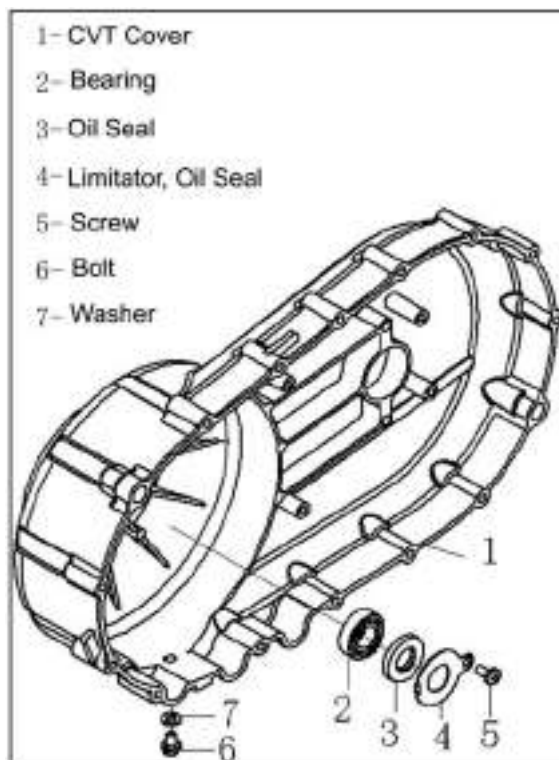

**Tool: Bearing Remover
Oil Seal Remover
Bearing Installer**

CVT Case

- Check bearing 5 for smooth turning. In case of any abnormal, remove screw 3 and bearing retainer 4 and replace with a new bearing.
- Check oil seal 7. In case of any damage, replace it;
- Apply grease to oil seal lip and install with special tool.
- Apply lubrication oil to bearing 5 and install with special tool; Check bearing for smooth turning. The seal side of bearing 5 should face bearing retainer 4.
- Install bearing retainer 4 and screw 3.
- Install oil seal 1 into clutch housing 2 with special tool.

**Tool: Oil Seal Installer
Bearing Installer**

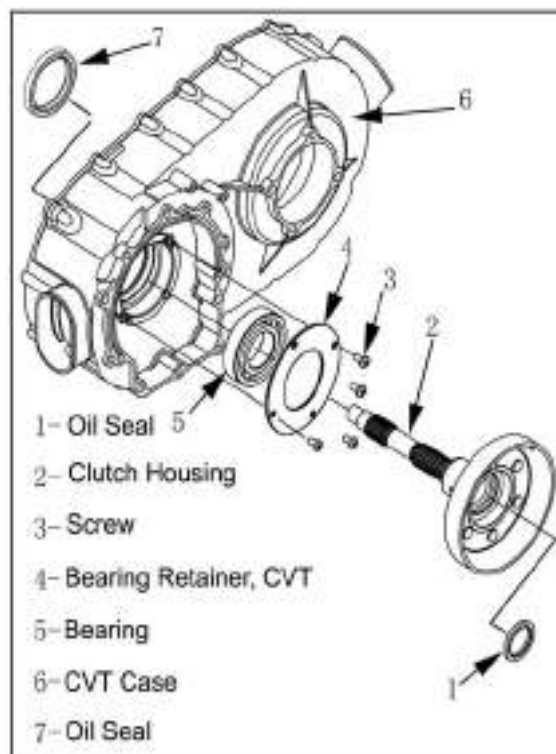

Crankcase

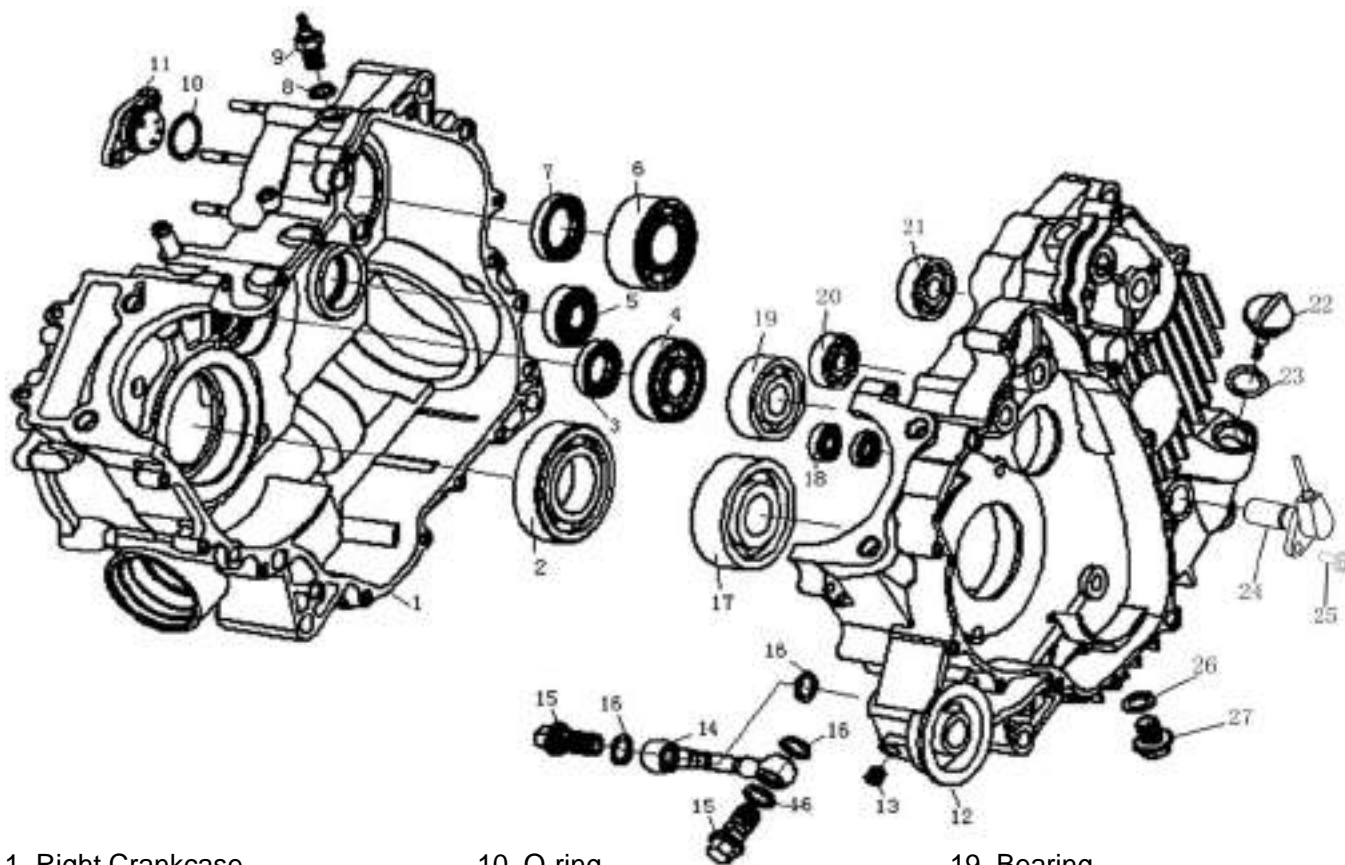

- | | | |
|--------------------------------|--------------------|-----------------------|
| 1. Right Crankcase | 10. O-ring | 19. Bearing |
| 2. Bearing | 11. Gear Sensor | 20. Bearing |
| 3. Oil Seal | 12. Left Crankcase | 21. Bearing |
| 4. Bearing | 13. Screw | 22. Oil Dip Rod |
| 5. Bearing | 14. Oil Pipe | 23. O-ring |
| 6. Bearing | 15. Link Bolt | 24. Speed sensor |
| 7. Oil Seal | 16. Washer | 25. Bolt |
| 8. Washer, Reverse Gear Sensor | 17. Bearing | 26. Washer |
| 9. Reverse Gear Sensor | 18. Bearing | 27. Oil Drainage Bolt |

- Clean and grease the bearings, turn the inner race of bearing and check the play, noise and smooth turning. In case of any abnormal, remove bearing with special tool and replace;
- Check all the oil seals for over wear or damage. In case of any over wear or damage, remove with special tool and replace with a new oil seal;
- Remove gear sensor 11 and check for continuity with reverse gear sensor 9 with a multimeter.
- Remove link bolt and oil pipe 14 and check oil pipe for crack or clog. Replace with a new one if any;
- Remove oil drainage bolt 27 and clean it.

Note: Check bearing for smooth turning after installation.

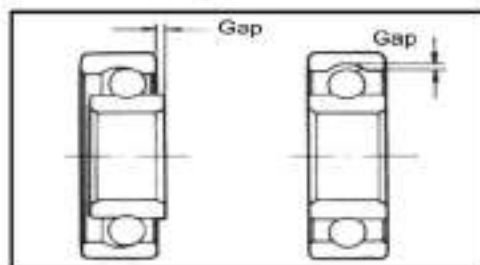
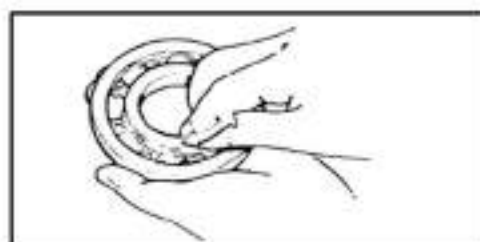

- Install new O-ring and apply grease;
- Install gear sensor;
- Install reverse gear sensor 9 and tighten to the specified torque.

- Reverse gear sensor tightening torque: 20N.m

- Install speed sensor 24

- Install oil pipe and tighten the link bolt to the specified torque;
Link bolt tightening torque: 18M.m

- Install washer 26 and oil drainage bolt 27 and tighten to the specified torque;
Drain bolt tightening torque: 30N.m

Tool: Bearing Remover
Bearing Installer
Multimeter

III Engine Assembly

Reverse the engine removal procedure for installation.

Caution:

- Clean all the parts before assembly;
- Make sure that the parts are in good condition without any damage;
- Apply engine oil to the moving parts before assembly;
- Apply grease to oil seal lip and O-ring

Caution:

Make sure that drive belt, primary and secondary sheaves are not stained with grease.

Engine Center

Oil Pump and Relief Valve

- Install oil pump and relief valve to left crankcase, as illustrated on the right. Tighten to the specified torque:

Oil pump bolt: 10N.m

Relief valve bolt: 10N.m

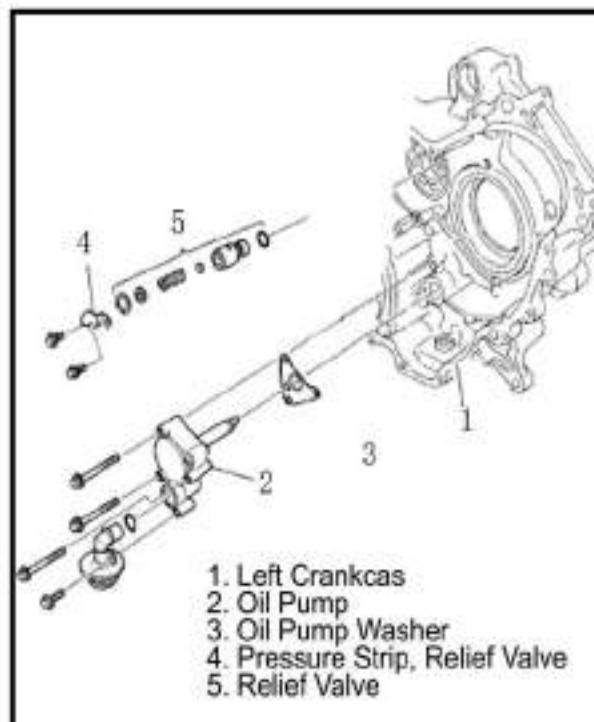

Connecting Rod

- Install connecting rod to left crankcase with special tool;

Note:

- Do not hammer the conrod into crankcase with plastic mallet;
- Use special tool to avoid affect of conrod precision

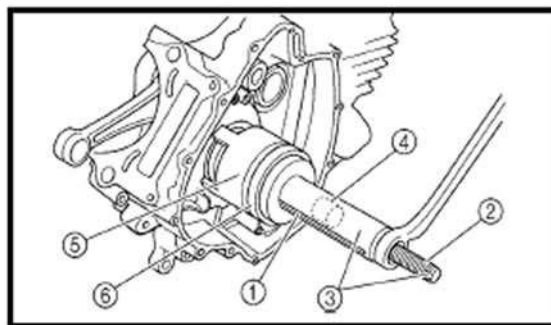

Tool: Conrod Installer

Balancer Shaft

- Install balancer shaft

Caution: Balancer shaft driven gear should be aligned to the mark as illustrated.

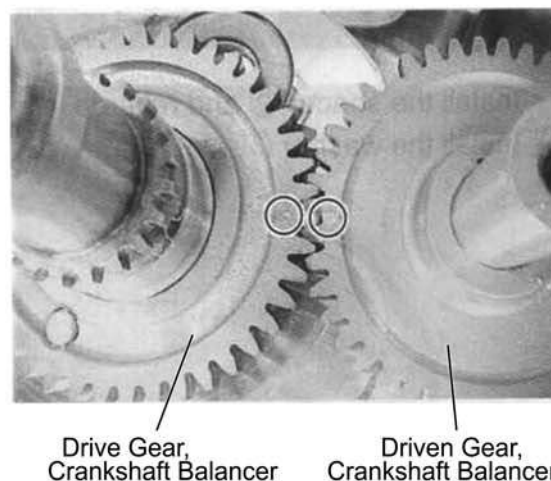

Main Shaft, Counter Shaft

- Install main shaft and counter shaft.

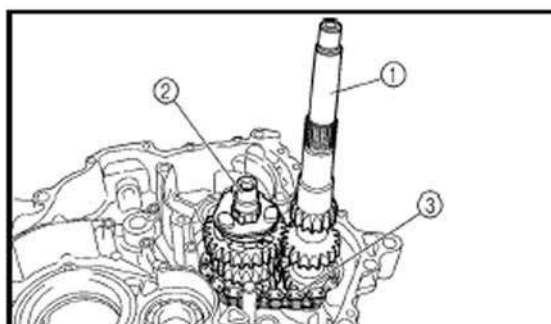

Shift Cam, Shift For

- Install shift can① and shift fork②
- Check each part for smooth turning
- Install low range driven gear to counter shaft③
- Spray adequate engine oil to each part.

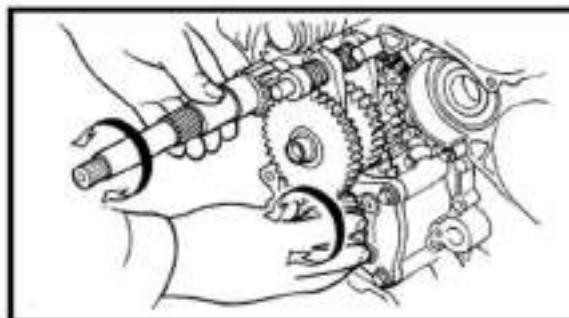
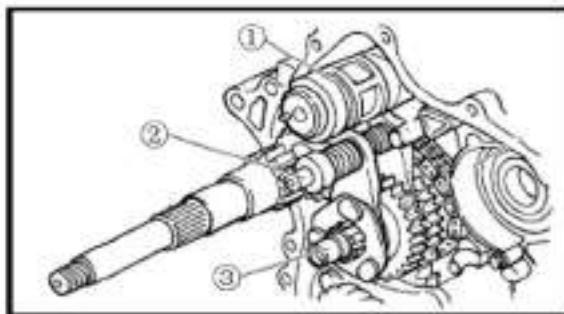

Drive Bevel Gear

- Install drive bevel gear and tighten to the specified torque.

Drive bevel gear tightening torque: 32N. m



Right Crankcase

Driven Bevel Gear

- Install driven bevel gear and tighten to the specified torque.

Driven bevel gear tightening torque: 25N. m

- Check bevel gear backlash (Refer to 12-44)



Front Output Shaft

- Install front output shaft to right crankcase

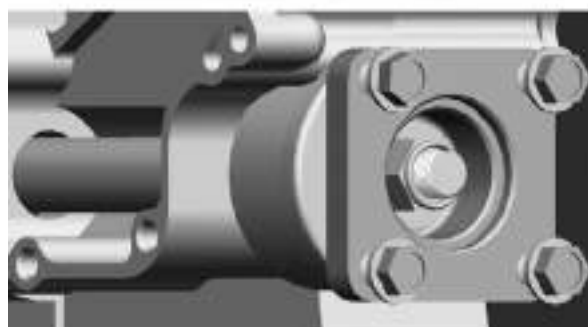

- Apply sealant ① to the mating face of right crankcase.

Note: Apply sealant evenly in an uninterrupted thin line.

- Install 2 dowel pins ②
- Assemble crankcase and tap slightly with a rubber hammer so that the crankcase is properly fitted.
- Install bolt and tighten to the specified torque.

**Crankcase bolt tightening torque: M6: 10N.m
M8: 25N.M**

Note: Crankcase bolts should be tightened diagonally in several steps.

- Place the steel ball and install gear positioning bolt and tighten the bolt to the specified torque.

Gear positioning bolt tightening torque: 18M.m

Engine Right

Timing Chain

- Put on timing chain 2

Clutch

- Install clutch 1 and nut 2. Tighten the nut to the specified torque (left thread).

Clutch nut tightening torque: 70N.m



- Install new o-ring⑥ in spacer⑧
- Install spacer onto the clutch housing shaft, then install into CVT case

Note: align oil nick on spacer with oil hole on the shaft

CVT Case

- Install dowel pin ④, gasket ② and gasket⑤ to the right crankcase. Install CVT case assembly to right crankcase.
- Install bolt ⑫ and nut③

Note:

- Tighten bolt/nut diagonally
- Use a new gasket

- Install air guide plate⑩ and screw⑪

●

Primary Sheave, Secondary Sheave, Drive Belt

- Install primary fixed sheave ①as illustrated on the right;

- Install drive belt between secondary sliding/fixed sheave and tap with a plastic hammer to keep the belt as low as possible.

Note:

- Install the drive belt with the arrow on the belt turn in the clockwise direction
- Drive belt contact surface should be free from any stains.

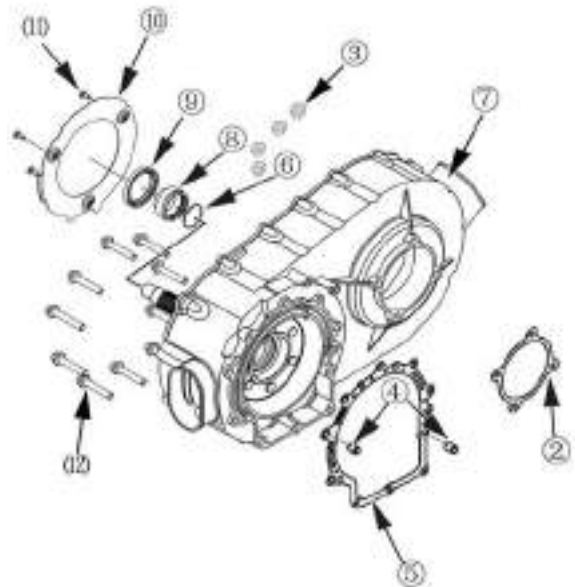

- Install secondary sheave;



- Install primary sliding sheave

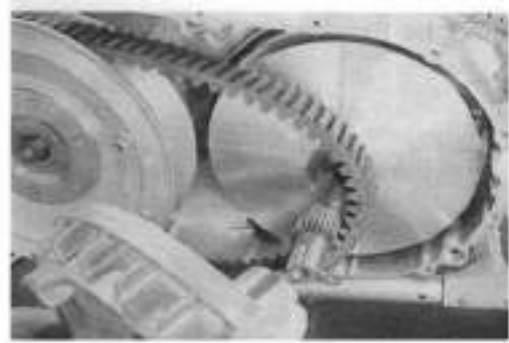

- Tighten primary sheave nut with special tool to the specified torque;

Primary sheave nut tightening torque: 115 N·m
Tool: Rotor Holder

- Tighten secondary sheave nut with special tool to the specified torque;

Secondary sheave nut tightening torque: 115 N·m
Tool: Rotor Holder



Note:

Turn the primary fixed sheave until the belt is seated in and both primary and secondary sheaves move together smoothly without slip.



CVT Case Cover

- Install the new gasket and dowel pins.



- Install CVT case cover bolts and tighten diagonally in several steps.

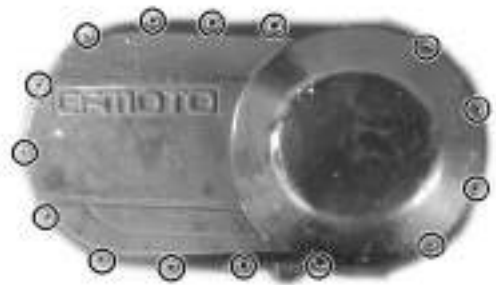

Engine Left

Oil Pump Sprocket and Chain

- Install oil pump drive sprocket;
- Install oil pump driven sprocket;
- Install oil pump drive chain;
- Install oil pump sprocket bolt;
- Install sprocket retainer with a long nose pliers

Tool: Long Nose Pliers

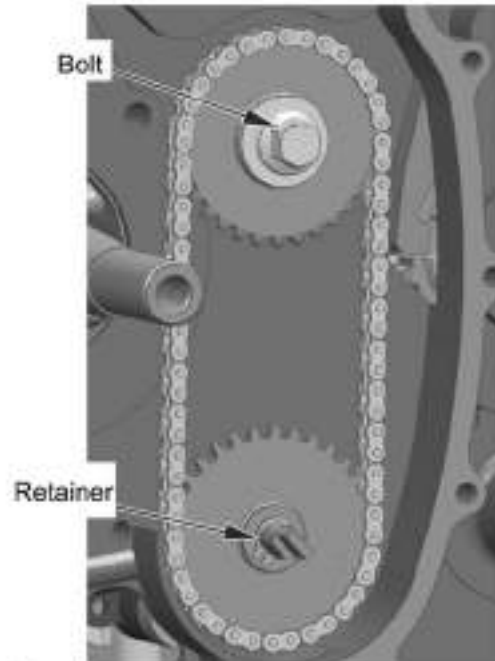

Dual Gear, Idle Gear

- Install dual gear shaft ① and dual gear ②
- Install dual gear ③, dual gear ④ and bush ⑤



Starting Driven Gear

- Install starting driven gear ⑥

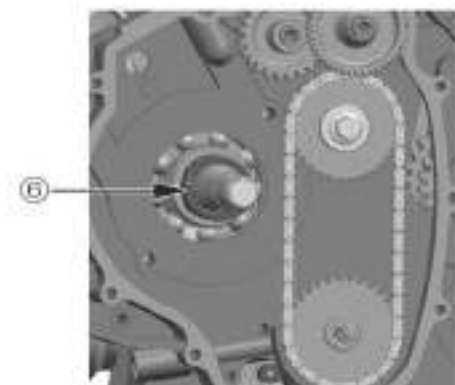

- Install starting driven gear;

Magneto Rotor

- Install woodruff key into crankshaft groove;
- Install magneto rotor 1;

Note: Degrease the tapered part of rotor and crankshaft. Use nonflammable solvent to clean off the oily or greasy matter and fully dry the surfaces.

Left Crankcase Cover

- Install dowel pin 2 and gasket 3

Note: Use a new gasket

- Apply Lubricant grease to oil sea lip;
- Install left crankcase cover;
- Install bolts;

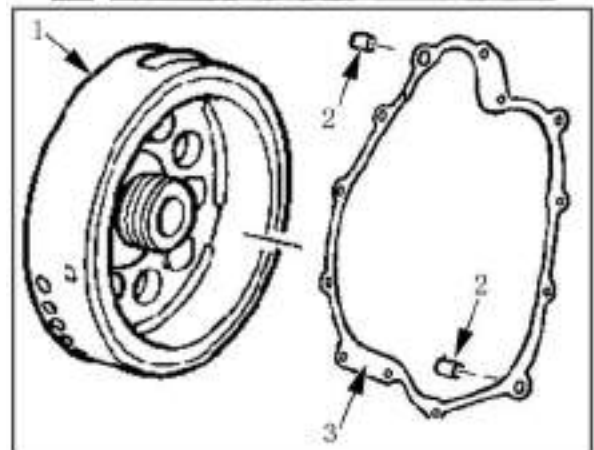
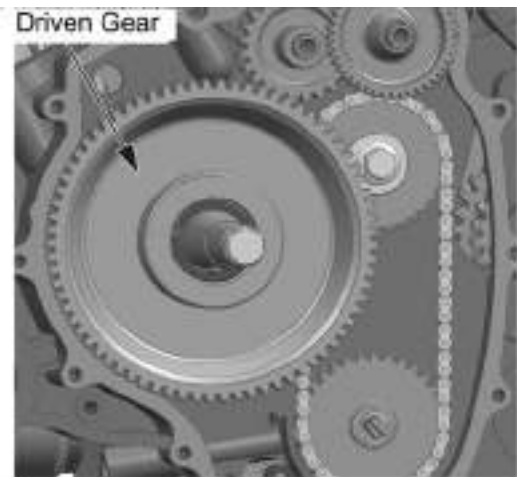

Recoil Starter

- Install recoil starter 1
- Install O-ring 2

Note: Use a new O-ring and apply lubricant grease to the O-ring

- Install washer 3 and bolt 4, tighten to the specified torque:

Recoil starter bolt tightening torque: 55N.m

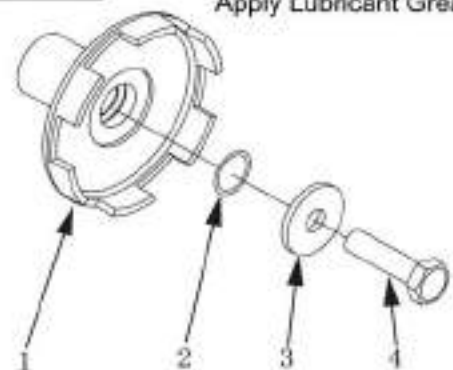

Water Pump

- Install water pump;
- Install water pump fixing bolts;

Note: Before tightening the bolts, be sure to insert oil pump shaft into groove of water pump shaft.

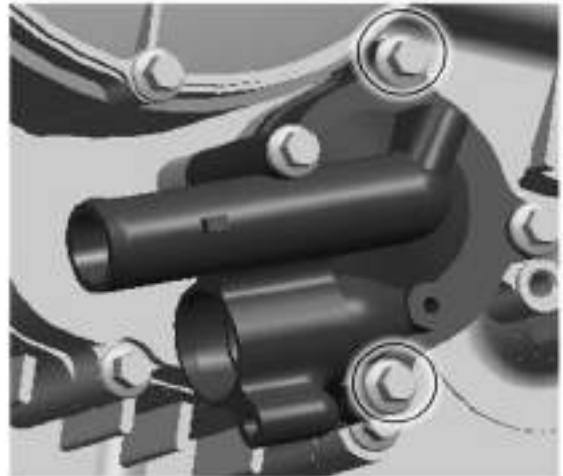

Sector Gear

- Install the parts as illustrated on the right.

- 1- sector gear cover and gasket
- 2-dowel pin
- 3-drive sector gear
- 4-driven sector gear
- 5-driven sector gear bolt

Note: When the shift cam is in the neutral position, the mark of drive sector gear should be between the two marks of the driven sector gear.

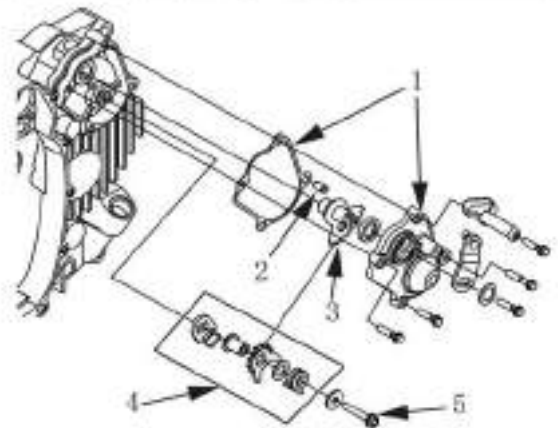

Driven sector gear tightening torque: 14N.m

- Install gearshift rocker arm
- Install rocker arm bolt 7 and washer 8

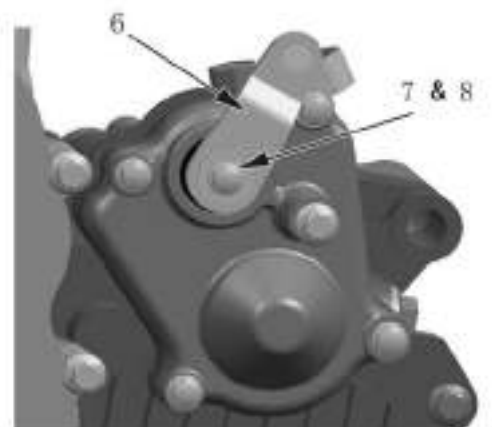

Oil Filter

- Install oil filter bolt and tighten to the specified torque;

Oil filter bolt tightening torque: 63 N·m

- Apply engine oil to O-ring;
- Install oil filter, turn it by hand until the filter gasket contacts the mating surface. Tighten the bolts to the specified torque.

Tool: Oil Filter Wrench

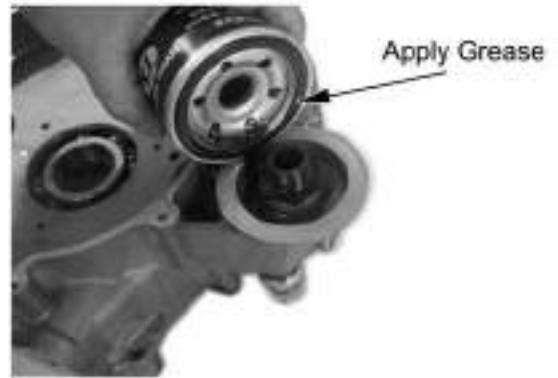

Starting Motor

- Apply engine oil to new O-ring;
- Install starting motor;
- Install bolt and tighten to the specified torque

Tightening torque: 10N·m

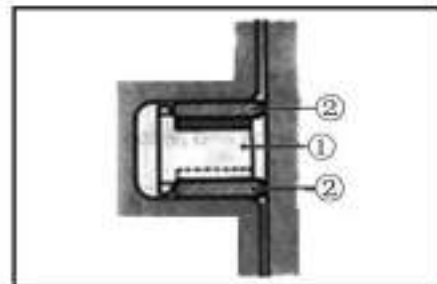

Engine Top Side

Piston

- Install the piston rings in the order of oil ring, ②ring and ①ring.;
- The first member to go into the oil ring groove is spacer①, after placing the spacer, fit the two side rails②.

Warning: when installing the spacer①, do not overlap its two ends in the groove.

Install the second ring A and first ring B

Note: 1st ring and 2nd ring differ in shape

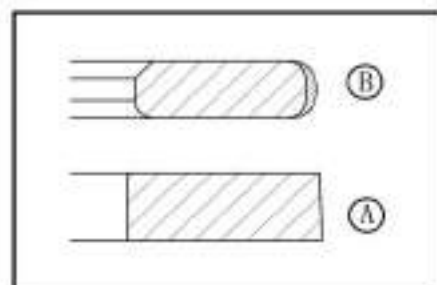
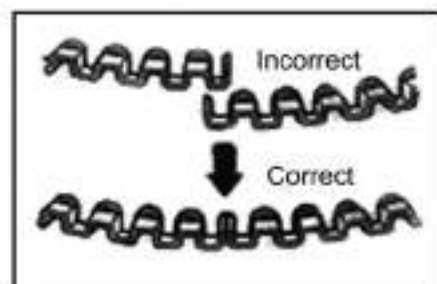

12. Engine Removal, Inspection and Installation

- 1st and 2nd rings have letter "R" marked on the side. Be sure to bring the marked side to the top when fitting them to the piston.

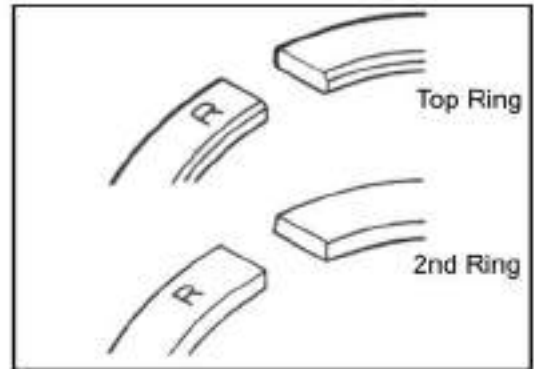

- Position the gaps of the three rings as illustrated on the right. Before installing the piston into the cylinder, check that the gaps are so located.

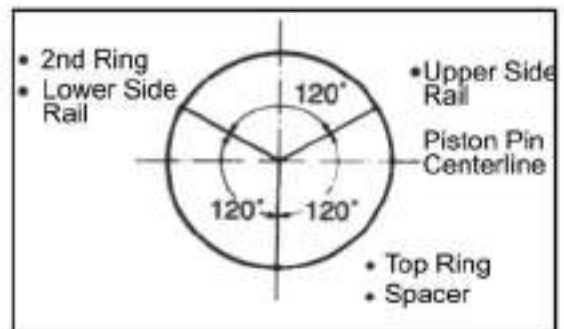

- Apply a light coat of moly oil to the piston pin;
- Install piston pin into holes of piston and conrod small end.

Note: When installing the piston, the "IN" mark on piston top is located to the intake side.



- Place a clean rag beneath piston and install piston pin circlip ①

Note: while rotating crankshaft, pull the cam chain upward, or the chain will be caught between sprocket and crankcase.



- Install the dowel pins and the new cylinder gasket;

Note: Use a new cylinder gasket to prevent oil leakage

Cylinder

- Apply engine oil to piston skirt and cylinder wall;
- Hold each piston ring with proper position, insert piston into the cylinder;
- Tighten the cylinder base bolts temporarily;

Note: When installing the cylinder and cylinder head, pull the cam chain upward, or the chain will be caught between sprocket and crankcase.



- Install chain guide①;
- Fit the dowel pin and new cylinder cover gasket;

Note: Use a new cylinder cover gasket to prevent oil leakage



Cylinder Head

- Install the cylinder cover, tighten the cylinder head bolts diagonally to the specified torque.

**Cylinder head bolt tightening torque: Initial: 25 N-m
Final: 38 N-m**



- Tighten the cylinder head nuts to the specified torque;

Cylinder head nuts tightening torque:

M6: 10 N-m
M8: Initial 10 N-m
Final 25 N-m



- Tighten the cylinder top nuts and cylinder base to the specified torque;

Tightening torque: 10 N-m



- Install chain tensioner;



Camshaft

- Align mark "A" on magneto rotor with mark "B" on crankcase;

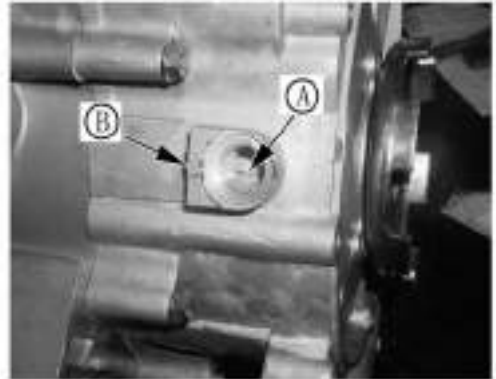

Note: while rotating crankshaft, pull the cam chain upward, or the chain will be caught between sprocket and crankcase.

- Align the mark "A" on the camshaft so that they are parallel with the mating surface of the cylinder head.

Note: Do not rotate the magneto rotor while doing this. when the sprocket is not positioned correctly, turn the sprocket;



- Engage the chain on the sprocket with the locating pin "B" as illustrated on the right;

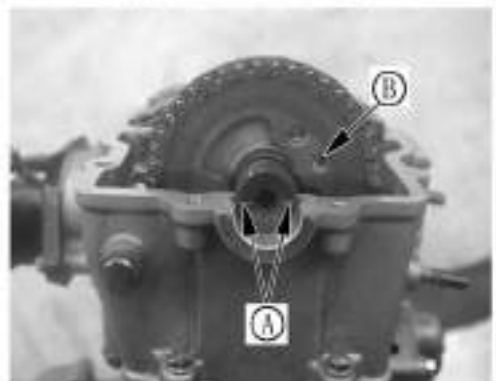

- Recheck if the position of mark "A" and "C" is correct. If not, reassemble until it is correct.



- Install crankshaft C-ring ①



- Install lock washer so that it covers the locating pin;
- Apply thread locker to the bolts before installing, and tighten them to the specified torque;

Sprocket bolt tightening torque: 15 N·m

- Bend up the lock washer to lock the bolts.



Cylinder Head Cover

- Clean the mating surface of cylinder head and cylinder head cover;
- Install dowel pin to the cylinder head
- Apply sealant to the mating surface of the cylinder head cover;



- Install cylinder head cover bolts, tighten diagonally to the specified torque.

Cylinder head cover bolt tightening torque: 10 N·m

Note: When tightening the cylinder head cover bolts, the piston must be at top dead center on the compression stroke.



Gasket Sealant Applying Place

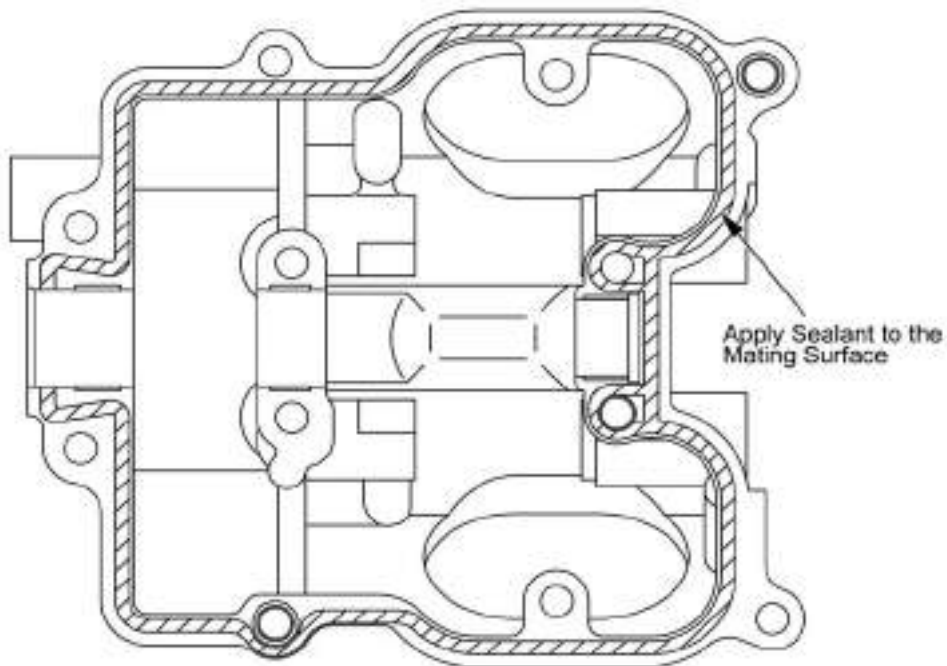

Chain Tensioner

- Insert (--) screwdriver into slotted end of chain tension adjuster, turn it clockwise to lock the tensioner spring;

- Install the chain tensioner and the new washer 1;
- Install the bolt 2, tighten it to the specified torque;

Chain tensioner bolt tightening torque: 10 N·m

- After chain tensioner is installed, turn the (--) screwdriver counter clockwise. The tensioner rod will be advanced under spring force and push tensioner against chain.

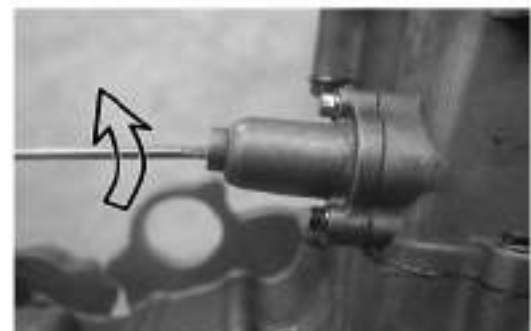
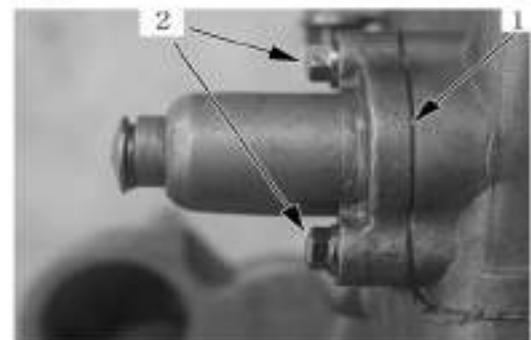

- Install the new gasket 3;
- Install chain tensioner screw, tighten it to the specifiedTorque

Chain tensioner screw tightening torque: 8 N·m

Valve Adjuster Cover

- Refer to 11-3 for valve clearance;
- Use new rubber gasket and apply grease;
- Install Valve Inspection Cap
- Install valve inspection cap bolt;

Spark Plug

- Install spark plug with special tool and tighten to the specified torque;

Note: To avoid damage to the cylinder head thread, screw in the spark plug with hand first, then tighten it to the specified torque with spark plug wrench.

Spark plug tightening torque: 18N.m
Tool: Spark Plug Wrench

Engine Periphery

- Recoil Starter
- Install recoil starter
- Apply thread locker to the bolts and then tighten;

Valve Inspection Cap

- Install valve inspection cap

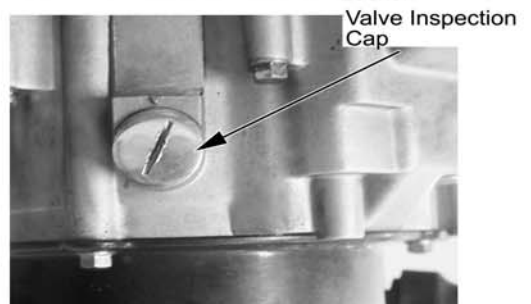
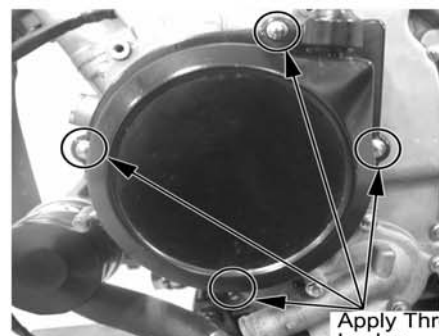
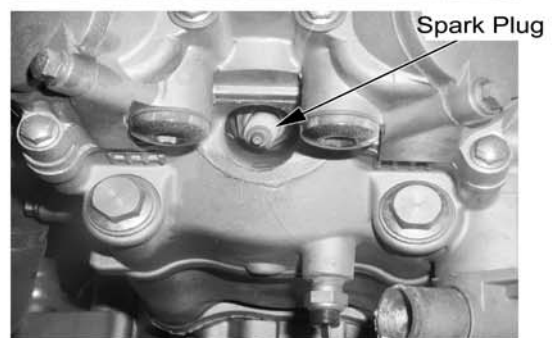
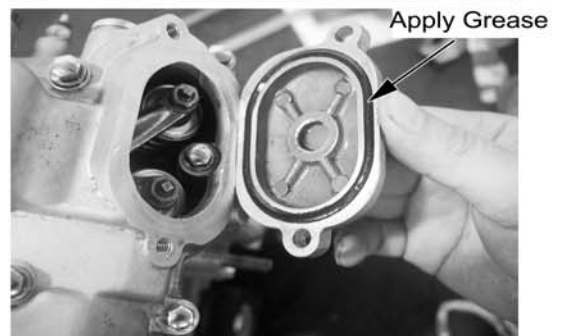
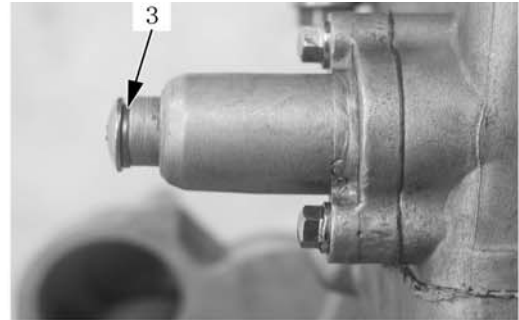

Left Plastic Cover

- Install left plastic cover 6

Water Pipe and Hose

- Install water hose 5
- Install bolt 4
- Install water hose 3
- Install clamp 1 and 2



Carburetor Removal.....	16-2
Inspection.....	16-3
Measurement and Adjustment.....	16-4
Carburetor Assembly.....	16-5
Carburetor Installation.....	16-6
Carburetor Parameters.....16-6

1. Carburetor Removal

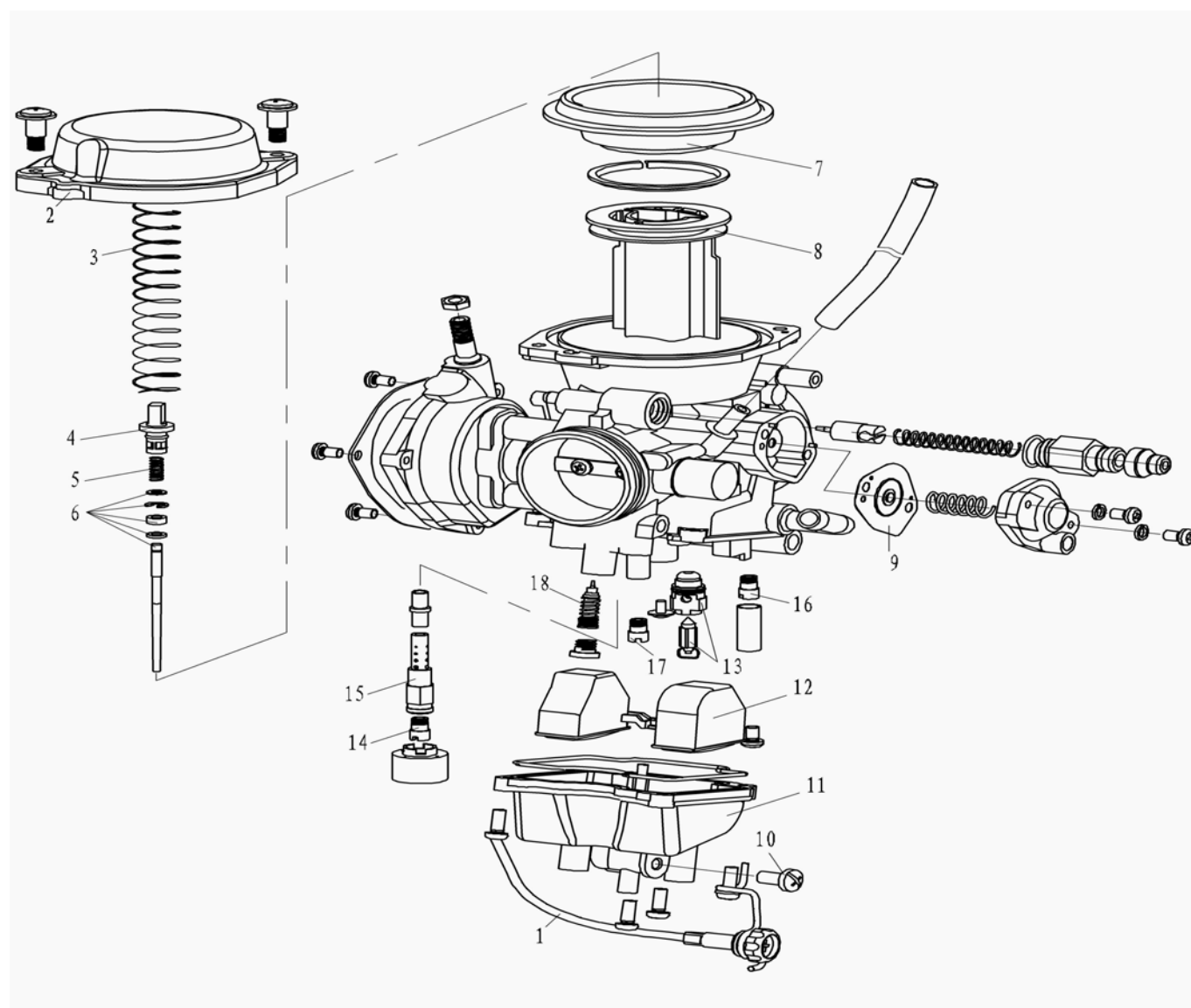

Disassemble the carburetor in the following serial number:

Serial No.	Description	Qty.	Serial No.	Description	Qty.
1	Idle Adjust Shaft	1	10	Drain Screw	1
2	Vacuum Chamber Cover	1	11	Float Chamber	1
3	Spring	1	12	Float	1
4	Jet Needle Holder	1	13	Needle Valve Set	1
5	Spring	1	14	Main Jet (MJ)	1
6	Jet Needle Set	1	15	Needle Jet (NJ)	1
7	Vacuum Diaphragm	1	16	Pilot Jet (PJ)	1
8	Piston Valve	1	17	Starter Jet (GS)	1
9	Enriching Diaphragm	1	18	Pilot Air Jet (PAJ)	1

2. Inspection

- Check carburetor body for cracks or damage.

Cracks or damage: → Replace

- Check carburetor float chamber, fuel passage for dirt or clog. Clean these parts.

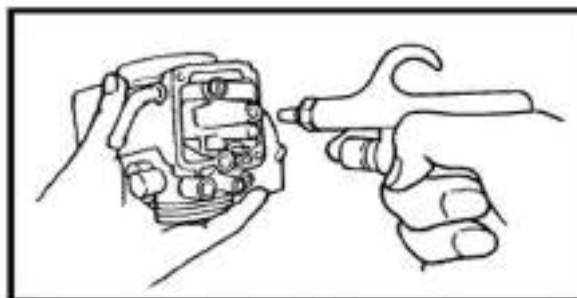

- Check float①, float tang ② for damage.

Damage: → Replace

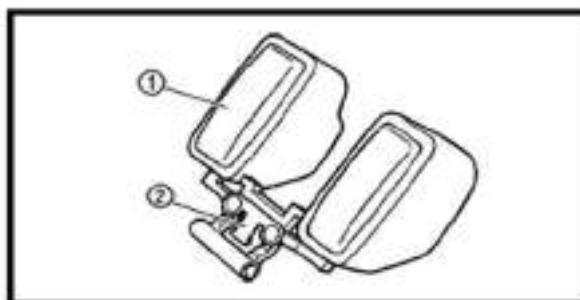

- Check valve seat①, needle valve②, O-ring③ for damage, abnormal wear or dirt.

Damage or wear or dirty: → Replace

Note: Valve set①, needle valve② should be replaced as a set.

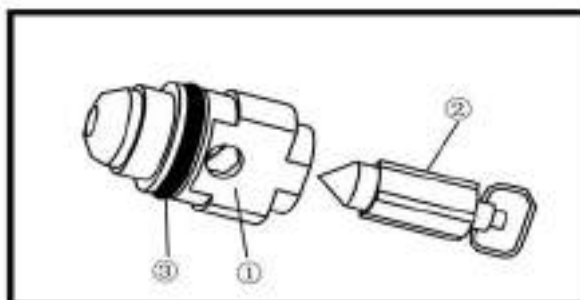

- Check piston valve① for scratches, abnormal wear or damage.

Scratches, wear or damage: → Replace

- Check diaphragm② for tears.

Tears: → Replace

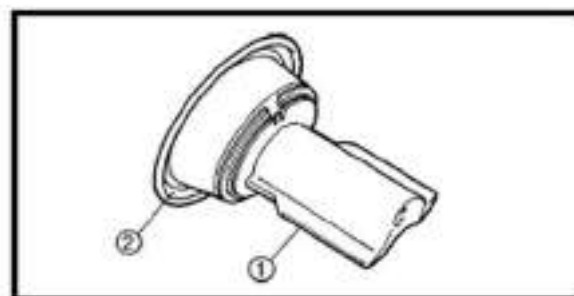

- Check vacuum chamber cover①, spring② for damage or cracks.

Damage or cracks: → Replace

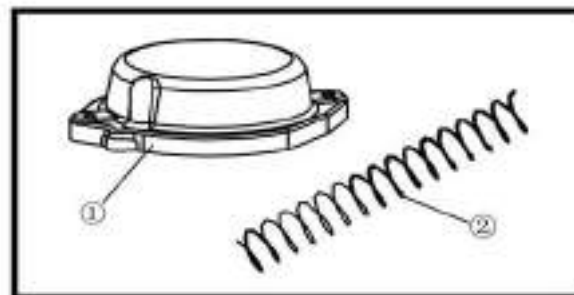

- Check the diaphragm ① for tears;

Tears: → Replace

- Check the spring ②, cover ③ for damage and tears;

Damage or tears: → Replace

- Check the jet needle①, mail jet②, needle jet③, pilot air jet④, pilot jet⑤, starter jet⑥ and starter plunger⑦ for wear and bends;

Wear or bends: → Replace

- Check above jets for clog. Blow out the jets with compressed air.

- Insert piston valve into carburetor body and check the free movement;

- Check free movement of throttle valve. Replace with a new one if it's stuck;

3. Measurement and Adjustment

- Keep the carburetor in a upside down position. Measure distance "a" from the mating surface of float chamber (without gasket) to the top of float.

Note: The float arm should rest on the needle valve. Do not compress the needle valve.

Float Height: $10 \pm 1\text{mm}$

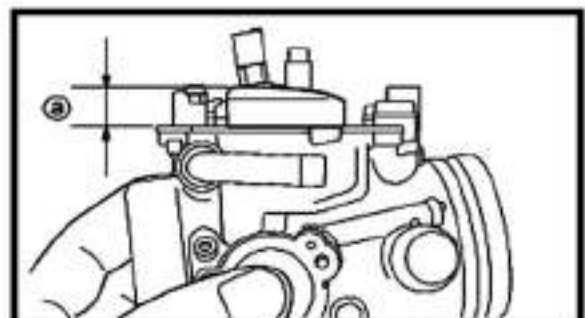
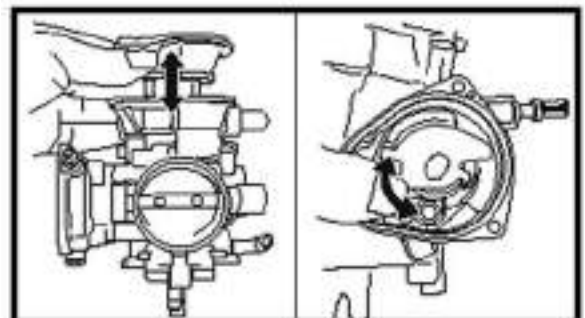
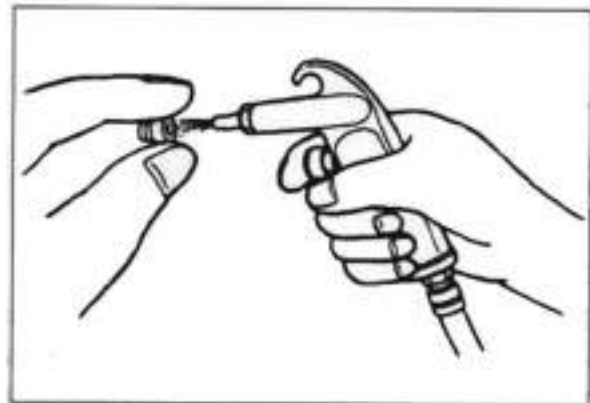
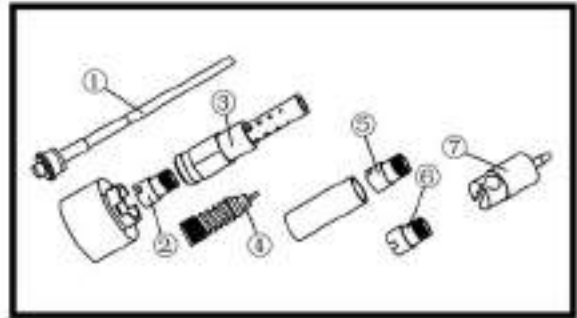
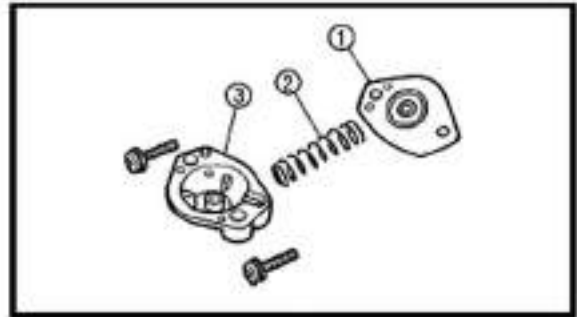

- If float height is not within the specification, check the valve seat and needle valve;
- If either of valve seat or needle valve is worn, replace both;
- If both are fine, adjust float height by bending the float tang ① on the float;
- Measure float height again till it's within the specification

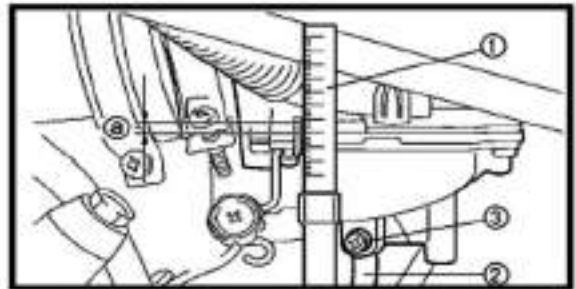
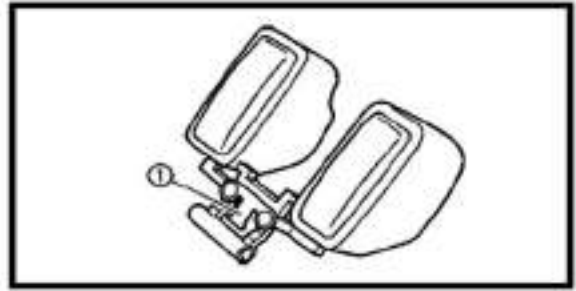

Fuel Level

- Place carburetor on a level surface. Connect fuel level gauge ① with drain pipe ②;

Tool: Fuel Level Gauge

- Loosen drain screw ③
- Keep fuel level gauge vertical next to the float chamber line and read the fuel level "a"

Fuel Level: $3.5 \pm 0.5\text{mm}$

- If the fuel level is not within the specification, adjust the fuel level;
- Remove carburetor
- Check valve seat and needle valve
- If either of valve seat or needle valve is worn, replace both;
- If both are fine, adjust float height by bending the float tang ① on the float;
- Install carburetor
- Check again the fuel level

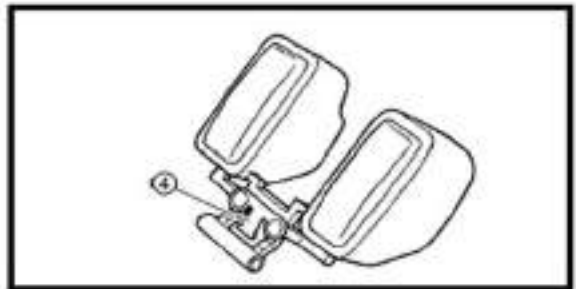

Carburetor Assembly

Reverse the disassembly procedure for assembly

Carburetor Installation

- ①-vacuum breather hose ②-starter cable ③-carburetor joint (engine intake manifold)
- ④-throttle valve cover ⑤-throttle cable ⑥-Carburetor joint (air filter) ⑦-carburetor
- ⑧-drain hose ⑨-fuel inlet hose

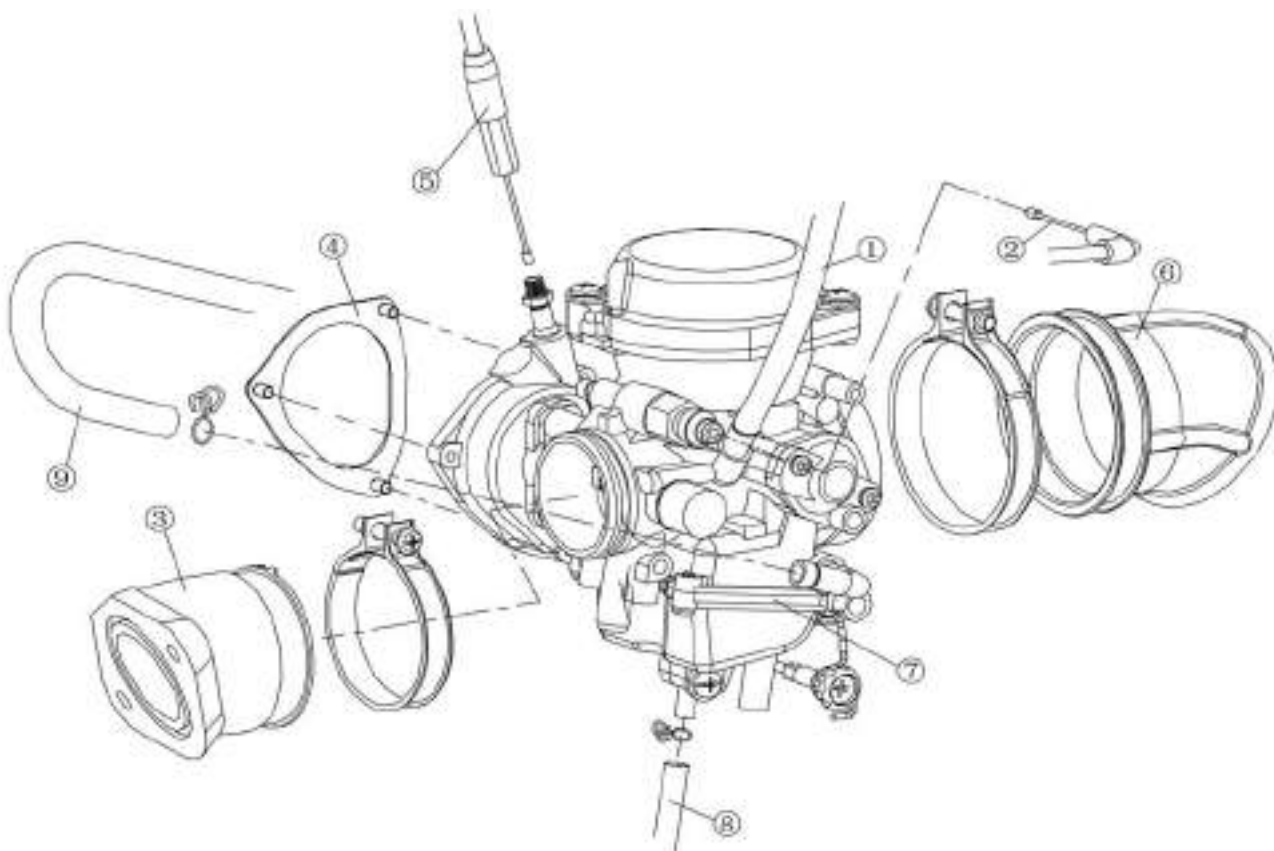

Note: Align the installation mark of carburetor and carburetor joint

6. Carburetor Parameters

Type	MIKUNI BSR36-89
Aperture No.	07G0
Throat size (mm)	36mm
Pilot (r/min)	1300 r/min ± 100 r/min
Float height (mm)	10±1
Fuel level (mm)	3.5±0.5
Main jet (MJ)	N102221-130#
Main air jet (MAJ)	MD13/24-35#
Jet needle (JN)	J8-5E26
Needle jet (NJ)	785-401011-P-OM
Pilot jet (PJ)	N224103-22.5#
Pilot screw (PS)	604-16013-1A
Pilot air jet1 (PAJ1)	MD13/24-65#
Pilot air jet2 (PAJ2)	N211100-165#



Cooling System Illustration.....	17-2
Engine Coolant.....	17-3
Inspection of Cooling Circuit.....	17-3
Inspection and Cleaning of Radiator and Water Hoses.....	17-4
Inspection of Fan Motor.....	17-5
Inspection of Water Temperature Sensor.....	17-6
Inspection of Thermostat.....	17-6
Water Pump.....	17-7
Water Pump Removal and Disassembly.....	17-7
Inspection.....	17-9
Water Pump Assembly and Installation.....	17-10
Lubrication System Illustration.....	17-14
Inspection of Lubrication System.....	17-15
Inspection of Oil Pump and Relief Valve.....	17-15

Cooling System Illustration

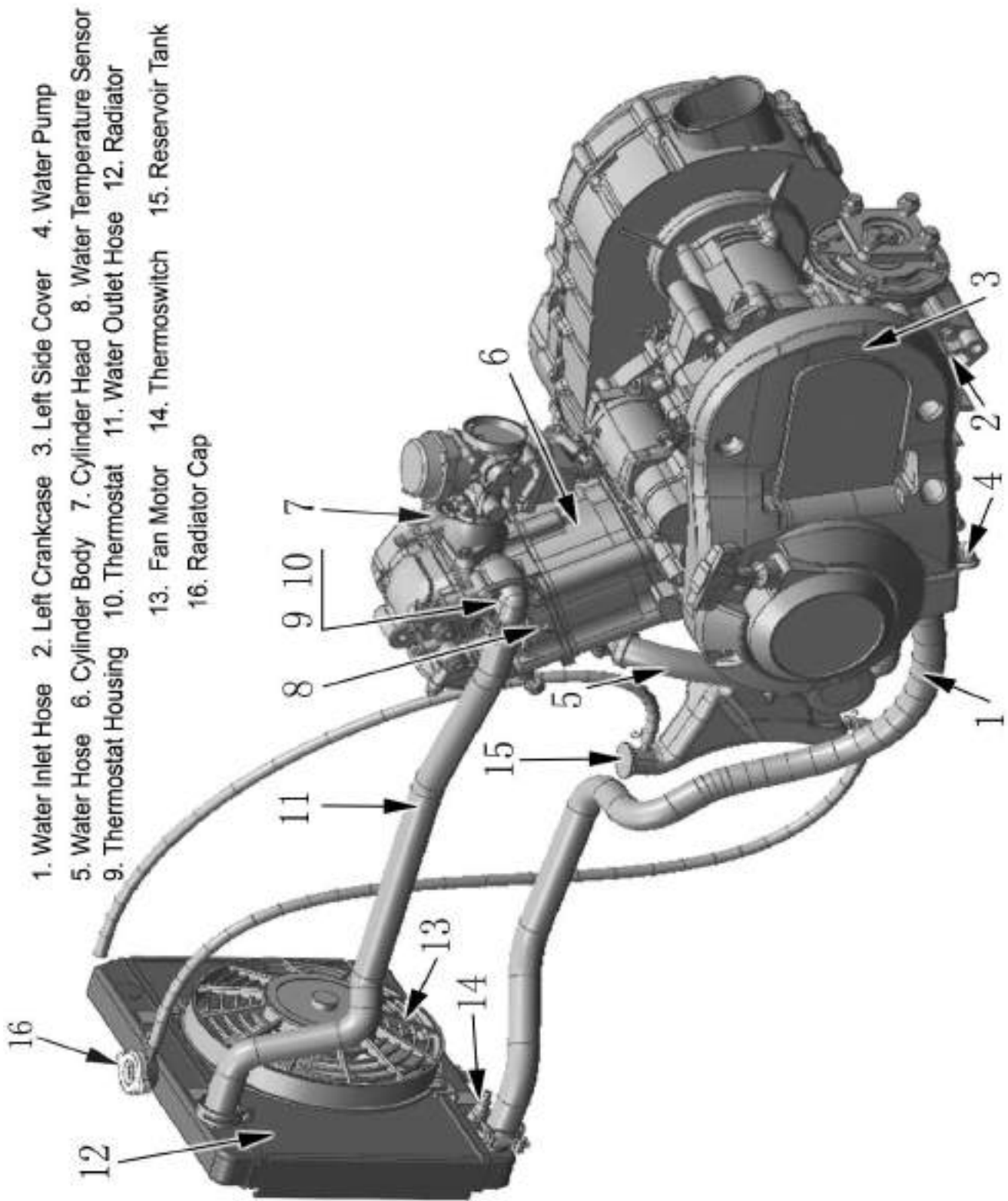

Engine Coolant

The coolant used in cooling system is a mixture of 50% distilled water and 50% ethylene glycol antifreeze. This 50:50 mixture provides the optimized corrosion resistance and fine heat protection. The coolant will protect the cooling system from freezing at temperature above -30°C . If the vehicle will be operated at the environmental temperature below -30°C , the mixing ratio of coolant should be increased to 55% or 60% according to the figure on the right.

Note: Use high quality ethylene glycol base antifreeze and mixed with distilled water. Never mix an alcohol base antifreeze and different brands of antifreeze;
The ratio of antifreeze should not be more than 60% or less than 50%;
Do not use anti-leak additive;

Warning !

- DO NOT open radiator cap when the engine is still hot. Or you may be injured by scalding fluid or steam;
- Coolant is harmful. DO NOT swallow or stain your skin or eyes with coolant. In case of accidental swallow or stains, flush with plenty of water and consult the doctor immediately.
- Keep coolant away from reach of children.

Inspection of Cooling Circuit

- Remove radiator cap ① and connect tester ② to filler.

Warning!

Do not open the radiator cap when the engine is still hot.

- Give a pressure of 120 kPa and check if the cooling system can hold this pressure for 10 seconds.
- If the pressure drops during this 10 seconds, it indicates that there is leakage with the cooling system. In this case, check the complete system and replace the leaking parts or components.

Warning!

- When removing the radiator cap tester, put a rag on the filler to prevent splash of coolant.

Warning!

- Do not allow a pressure to exceed the radiator cap release pressure.

Anti-Freeze Density	Freezing Point
50%	-30°C
55%	-40°C
60%	-55°C

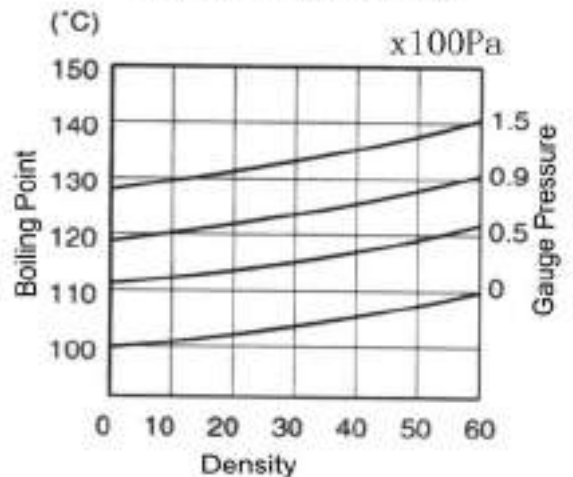
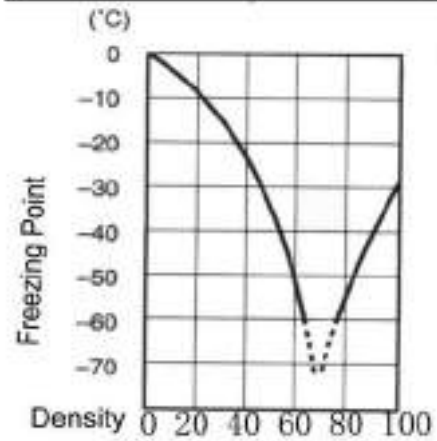

Inspection and Cleaning of Radiator and Water Hoses

Radiator Cap

- Remove radiator cap①
- Install radiator cap to cap tester②
- Slowly increase pressure to 93.3-122.7 kPa and check if the cap can hold the pressure for at least 10 seconds.
- If the cap cannot meet the pressure requirement, replace it.

Radiator Cap Valve Opening Pressure:

Standard: 93.9-122.9 kPa

Tool: Radiator Cap Tester

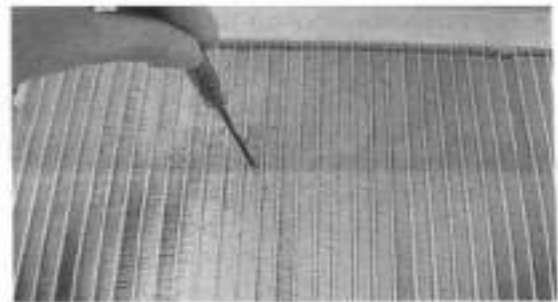

Radiator Inspection and Cleaning

- Remove dirt or trash from radiator with compressed air;
- Correct the radiator fins with a small screwdriver;

Radiator Hose Inspection

- Check radiator hoses for leakage or damage.

Leakage or Damage: → Replace

- Check tightening of clamps. Replace the clamps if necessary;
- After inspection and cleaning of radiator and hoses, check coolant level. Fill coolant if necessary.



Inspection of Fan Motor

- Remove fan motor from radiator
- Turn the vanes and check if they can turn smoothly;
- Check fan motor: Make sure that the battery applies 12 volts to the motor and the motor will run at full speed while the ammeter shall indicate the ampere not more than 5A.
- If the motor does not run or the ampere exceeds the limit, replace the motor.
- Installation: Apply a little thread locker to the bolts and tighten to the specified torque.

Fan Motor Bolt Tightening Torque: 10N.m

Inspection of Thermoswitch

- Remove thermoswitch
- Check the thermoswitch for closing or opening by testing it at the bench as illustrated. Connect the thermoswitch① to the circuit tester, place it in a vessel with engine oil. Place the vessel above a stove.
- Heat the oil to raise the temperature slowly and take the reading from thermometer ② when the thermoswitch closes and opens.

Tool: ammeter

Thermoswitch Operating Temperature

Standard: (OFF-ON): Approx. 88°C

(ON-OFF): Approx. 82°C

Note:

- Avoid sharp impact on thermoswitch.
- Avoid contact of thermoswitch with thermometer or vessel
- **Installation:** Use a new O-ring③ and tighten the thermoswitch to the specified torque:

Thermoswitch Tightening Torque: 17N.m

- Check coolant level after installation of thermoswitch. Fill coolant if necessary.

- 1. Radiator
- 2. Radiator Cap
- 3. Fan Motor
- 4. Mounting Bolt, Fan Motor
- 5. Thermoswitch

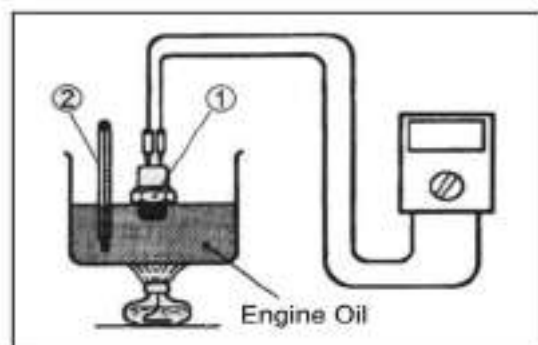
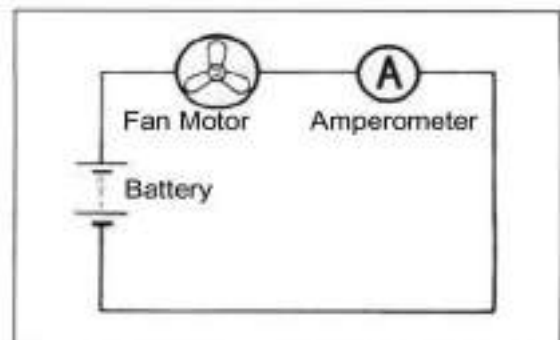
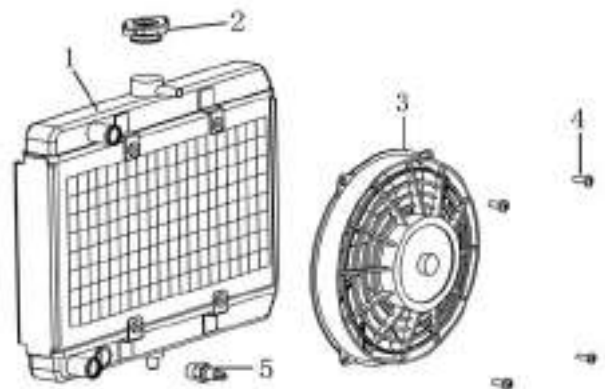

Inspection of Water Temperature Sensor

- Place a rag under water temperature sensor① and remove it from cylinder head.
- Check the resistance of water temperature sensor as illustrated on the right. Connect the temperature sensor② to the circuit tester, place it in a vessel with engine oil. Place the vessel above a stove.
- Heat the oil to raise the temperature slowly and take the reading from thermometer ③ and ohmmeter ④ .

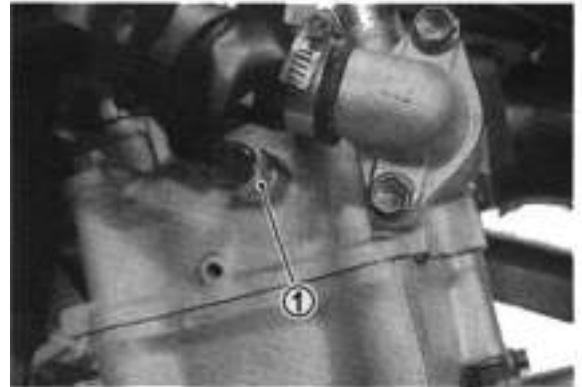

Water Temperature and Resistance

Temperature(°C)	50	80	100	120
Resistance(Ω)	154±16	52±4	27±3	16±2

Installation: Apply a little thread locker and install it to the cylinder head by tightening to the specified torque.

Water Temperature Sensor Tightening Torque: 10N.m

Note:

- Avoid sharp impact on temperature sensor
 - Avoid contact of temperature sensor with thermometer or vessel
- After installation, check the coolant level. Fill coolant if necessary.

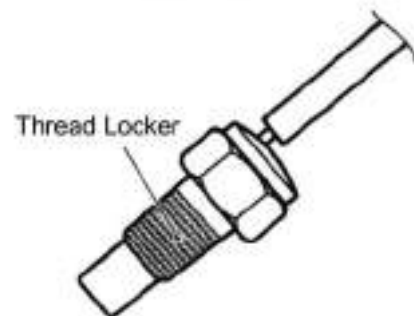
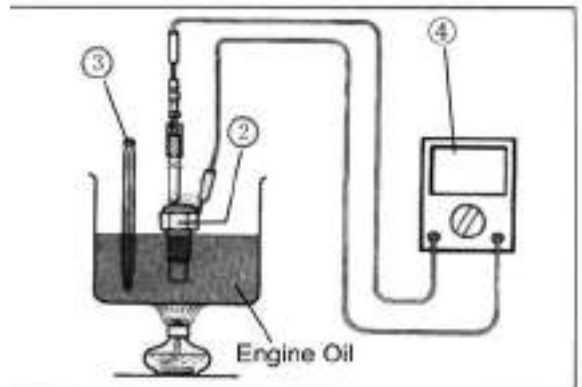

Inspection of Thermostat

- Remove thermostat case
- Remove thermostat

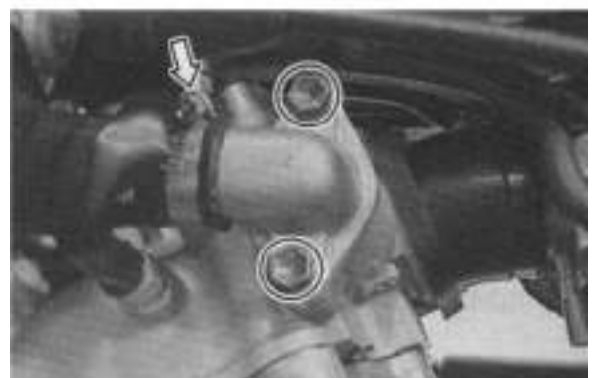

- Check thermostat pellet for cracks
- Test the thermostat in the following steps:
 - Pass a string between thermostat flange as illustrated on the right;
 - Immerse the thermostat in a beaker with water. Make sure that the thermostat is in the suspended position without contact to the vessel. Heat the water by placing the beaker above a stove and observe the temperature rise on a thermometer;
 - Take the temperature reading from thermometer when the thermostat valve opens.

Thermostat Valve Opening Temperature: 68-74°C

- Keep heating the water to raise the water temperature.
- Just when the water temperature reaches the specified value, the thermostat valve should have been lifted by 3.5-4.5mm

Installation:

- Reverse the removal procedure for installation.
- Apply coolant to the rubber seal of thermostat.
- Install thermostat case. Tighten to the specified torque:

Tightening Torque: 10N.m

Water Pump

- Removal and Disassembly
 - Remove engine left side cover;
 - Drain coolant (→11-10)

Note: Before draining coolant, check water pump for oil or coolant leakage. In case of oil leakage, check the water pump oil seal, O-ring. In case of coolant leakage, check the water seal.

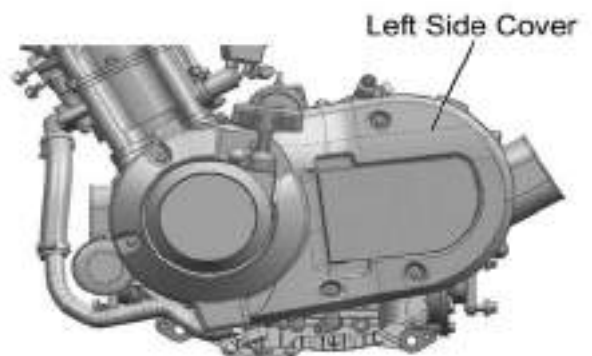
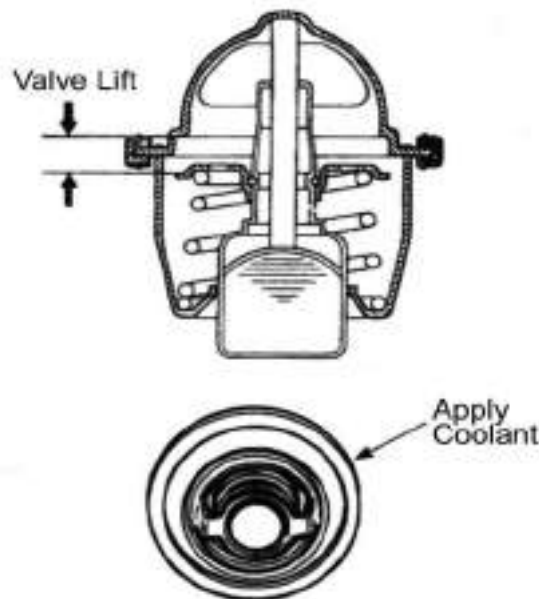
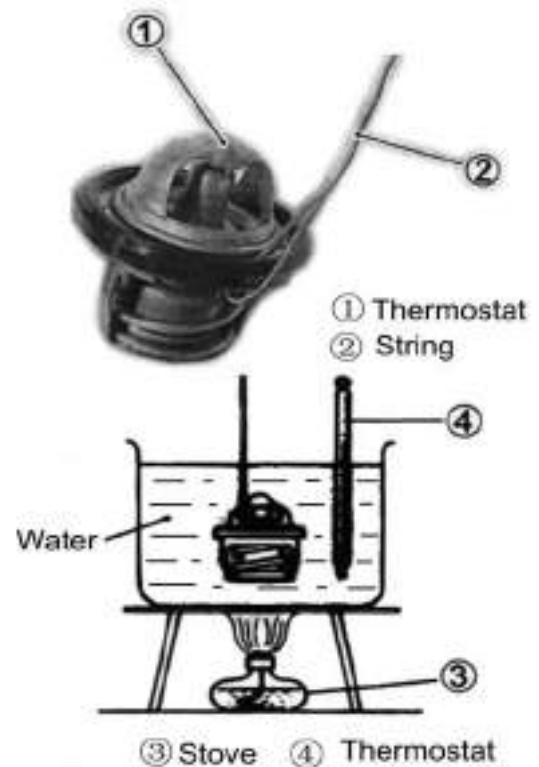

- Remove clamps and water hoses
- Release bolts and remove water pump
- Remove O-ring

Note: Do not reuse the O-ring.

- Remove the overflow tube
- Release water pump cover screws, water pump cover and gasket
- Remove E-ring and impeller
- Remove seal ring ① and rubber seal ②



- Remove mechanical seal with special tool

Note: The mechanical seal does not need to be removed if there is no abnormal condition.

Note: Do not reuse a removed mechanical seal

- Put a rag on the water pump body
- Remove oil seal.

Note: The oil seal does not need to be removed if there is no abnormal condition

Note: Do not reuse a removed oil seal

- Remove bearing with special tool.

Note: The bearing does not need to be removed if there is no abnormal noise.

Note: Do not reuse a removed bearing.

Inspection of Water Pump

Bearing

- Check the play of bearing by hand while it is still in the water pump body;
- Turn inner race of bearing to check for abnormal noise and smooth rotation;
- Replace the bearing if there is abnormal condition;

Mechanical Seal

- Check mechanical seal for damage, pay special attention to the seal face;
- In case of leakage or damage, replace the mechanical seal. If necessary, also replace the seal ring.

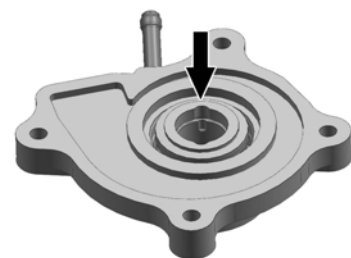
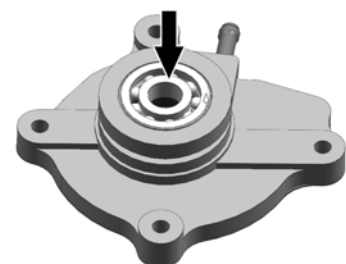
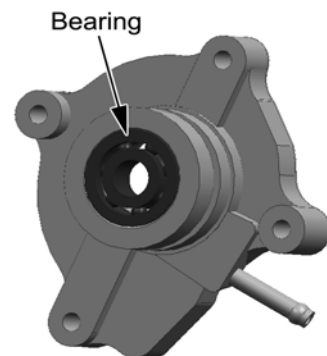
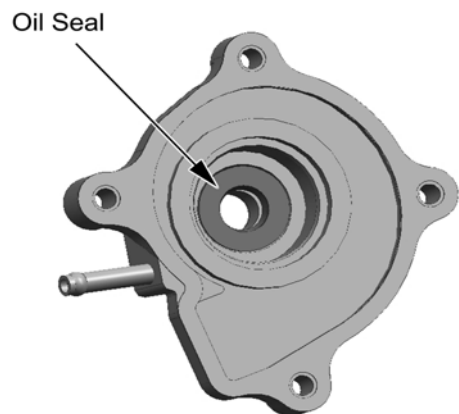
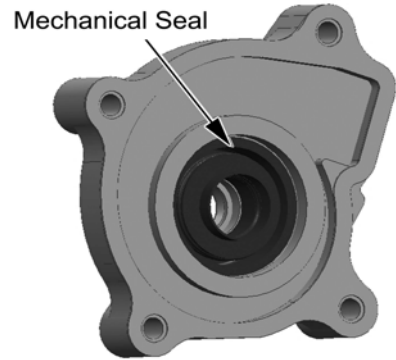

Oil Seal

- Check oil seal for damage. Pay special attention to the oil seal lip;
- In case of damage or leakage, replace the oil seal;



Water Pump Body

- Check the mating face of water pump body with bearing and mechanical seal.
Damage: →Replace



Impeller

- Check the impeller and shaft for damage.
Damage: →Replace



Assembly and Installation of Water Pump

- Install oil seal with special tool;

Tool: Oil Seal Installer

Note: The stamped mark on the oil seal faces outside

- Apply a little grease to the oil seal lip.

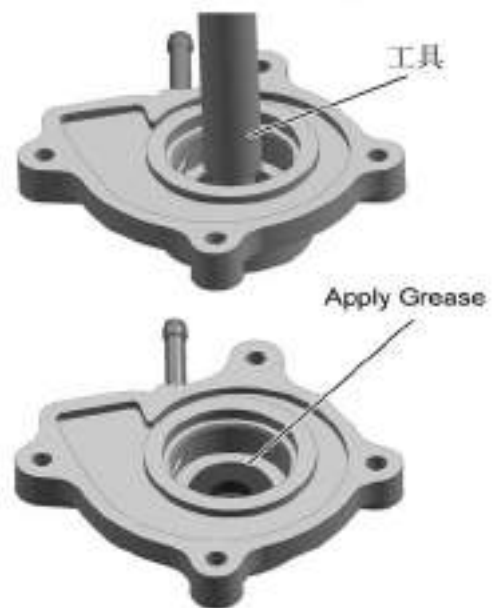

- Install mechanical seal with a suitable socket wrench

Note: Apply sealant to side “A” of mechanical seal



- Install bearing with special tool

Tool: Bearing Installer

Note: The stamped mark on the bearing faces outside.

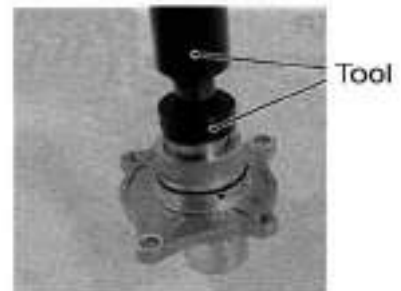

- Install seal ring to impeller
- Clean off the oil and grease from mechanical seal and install it into the impeller.

Note: “A” side of mechanical seal faces impeller



- Apply grease to impeller shaft
- Install impeller shaft to water pump body.



- Install E-ring to water pump shaft;



- Install new gasket to water pump body;

- Install water pump cover and tighten the bolts and bleed bolt.

Water Pump Cover Bolts Tightening Torque: 6N.m



- Check impeller for smooth turning.

- Install the new O-ring



Note:

- Use the new O-ring to prevent oil leakage;
- Apply grease to O-ring

- Install water pump and tighten the bolts to the specified torque;

Water pump bolts tightening torque: 10N.m



Note: Set the water pump shaft slot end “B” to oil pump shaft flat side “A”.

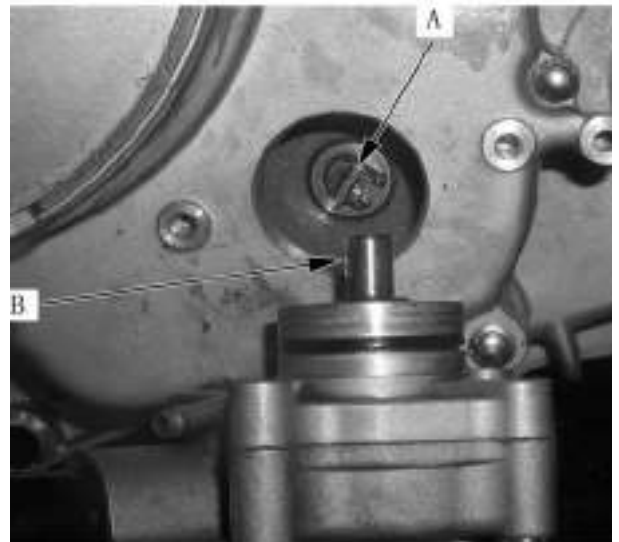

- Connect water hoses
- Add coolant
- Install left side cover

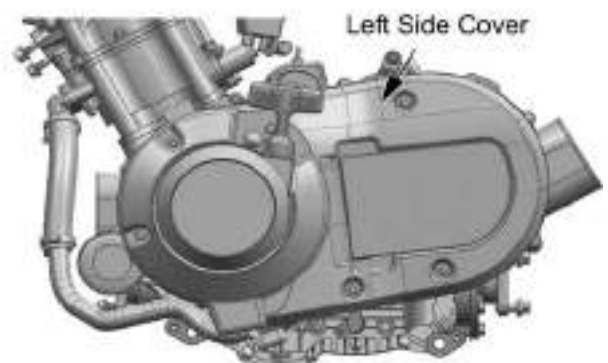
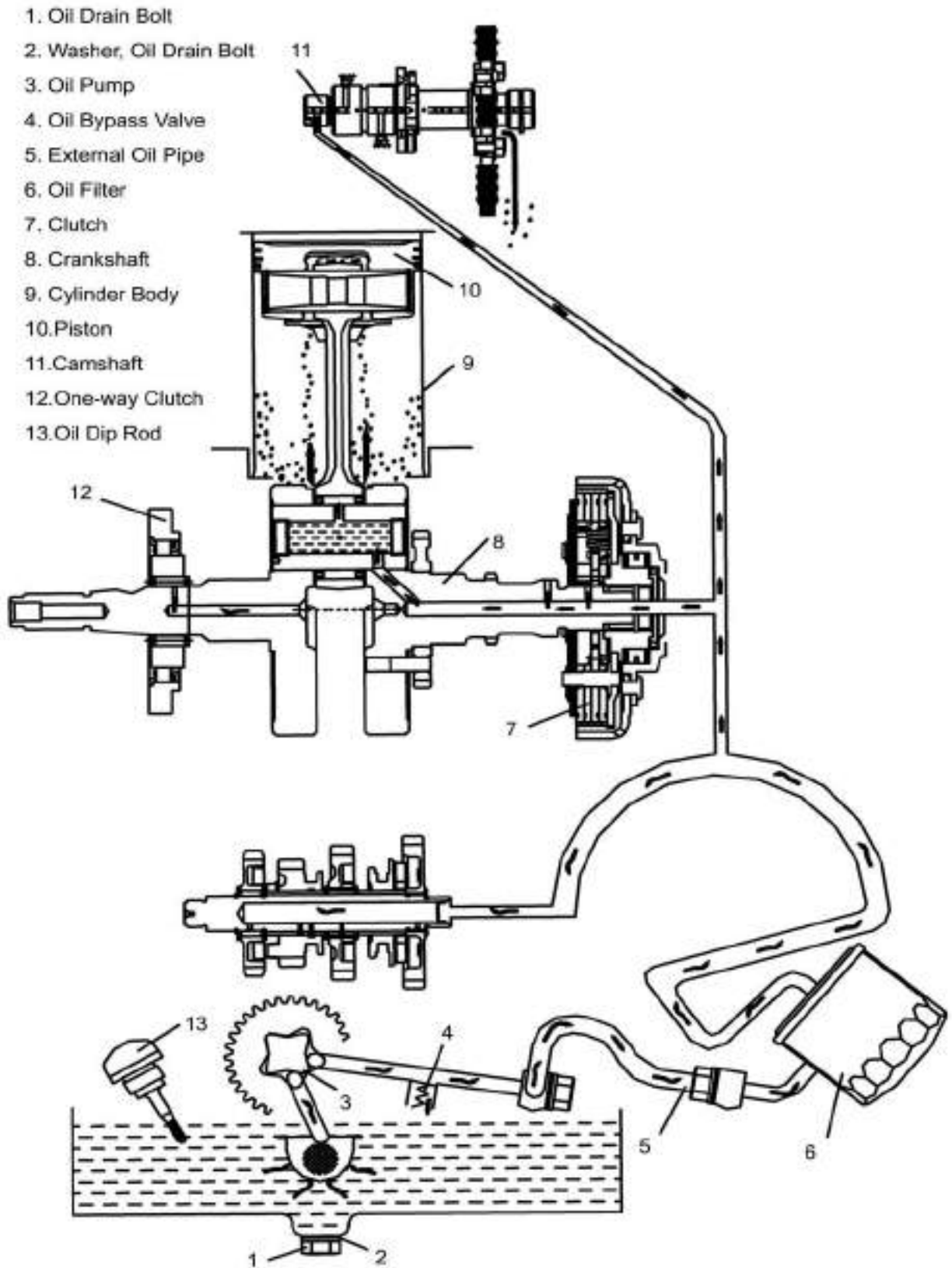

Illustration of CF188 Engine Lubrication System



Inspection of Lubrication System (→11-8)

Inspection of Oil Pump and Relief Valve(→12-41)

Charging System.....18-1

Electric Starting.....18-3

Ignition System.....18-5

Charging System

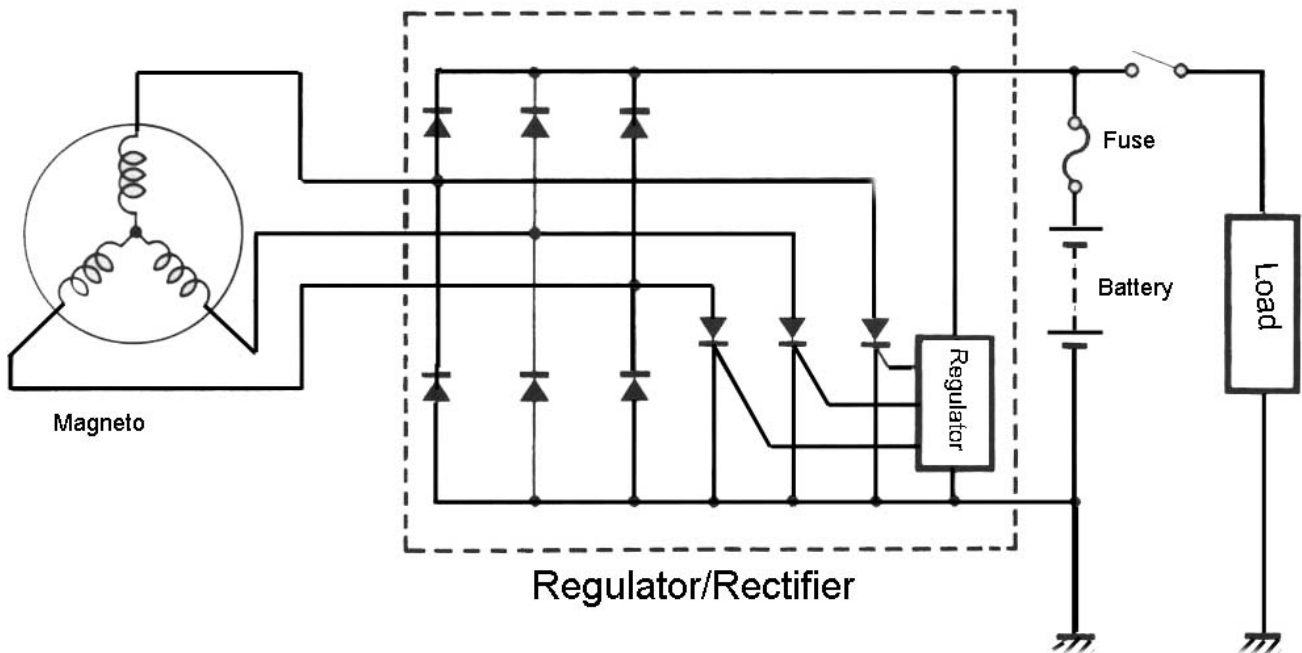

Resistance of Generator Coil

- Measure resistance between the three lead wires;
- Replace a new stator coil if resistance not within specified value,
- Check that the generator core is insulated.

Set multimeter at $1 \times 10 \Omega$

Generator Coil Resistance : $0.9-1.5 \Omega$ (Yellow-Yellow)

Insulate Resistance: $\infty \Omega$ (Yellow-Earthing wire)

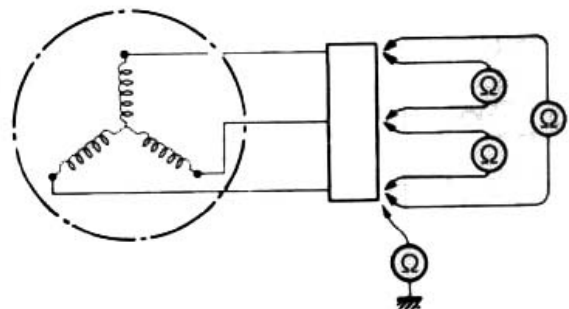

Generator Non-load Performance

- Start engine run it at 5000r/min
- Measure AC voltage between three lead wires of generator with multimeter.
- Replace the generator if the voltage is lower than the specified value.

Set Multimeter to AC Position

Generator Non-load Performance:

> 200V (AC) at 5000r/min

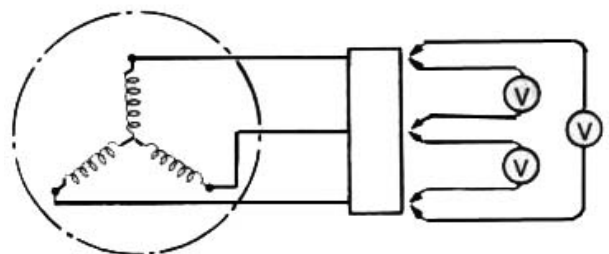

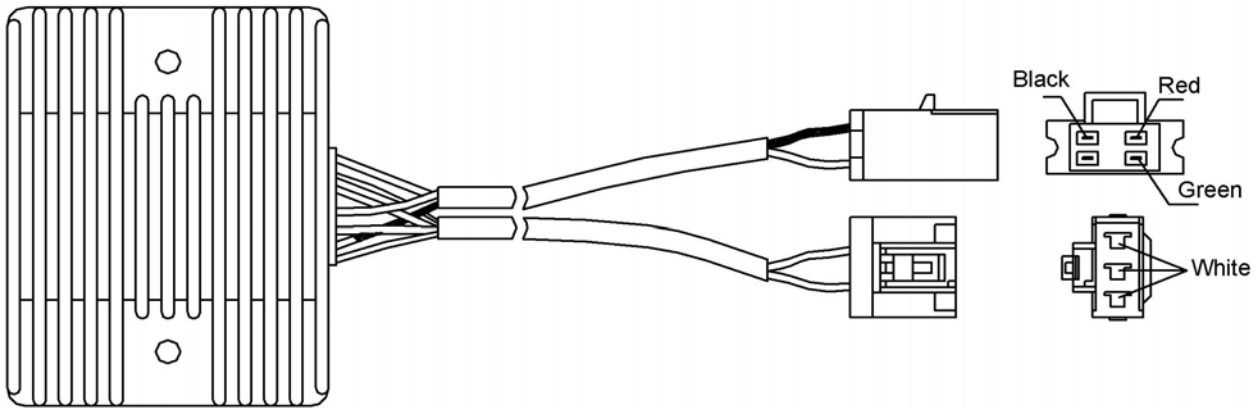

Regulator/Rectifier

- Measure the resistance between the terminals using a multimeter.
- If any of the resistance is not within the specified value, replace the regulator/rectifier.

NOTE:

If the multimeter reads under 1.4V when the probes are not connected, replace the multimeter battery.

		Red ⊕					
		Yellow	Yellow	Yellow	Green	Red	Black
Black ⊖	Yellow		∞	∞	400-500	∞	∞
	Yellow	∞		∞	400-500	∞	∞
	Yellow	∞	∞		400-500	∞	∞
	Green	∞	∞	∞		∞	∞
	Red	400-500	400-500	400-500	750-850		∞
	Black	∞	∞	∞	∞	∞	

Starting System

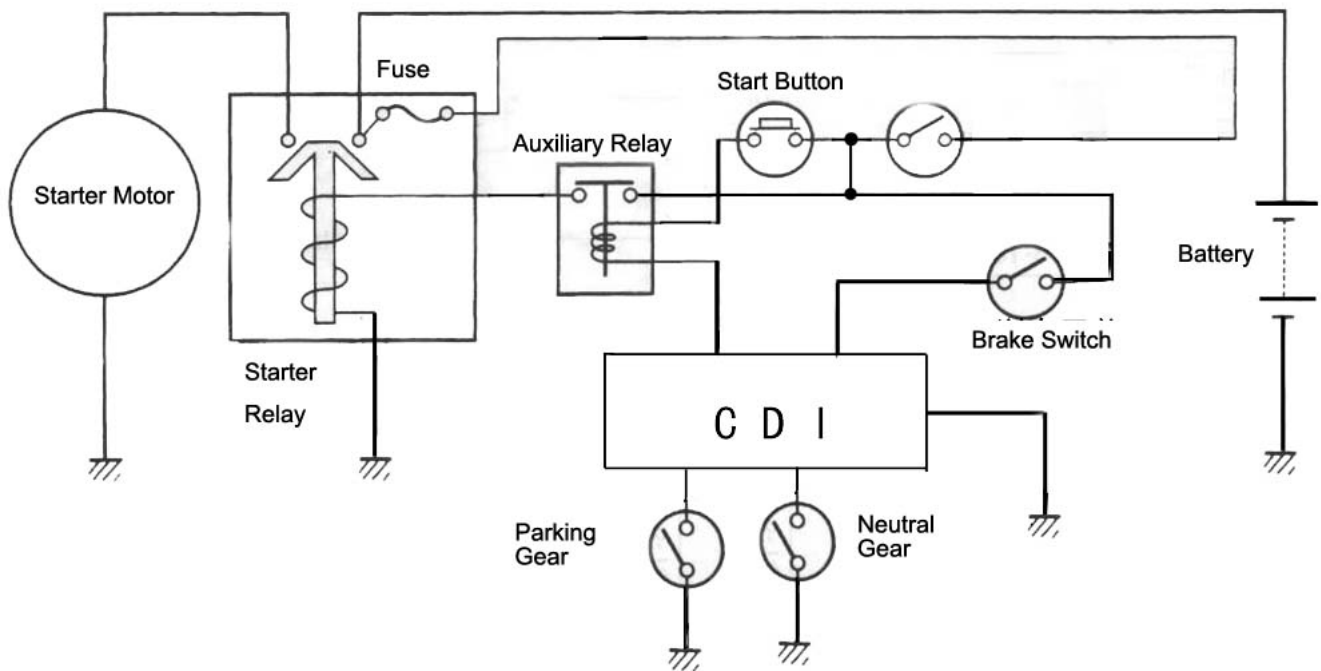

Starting Motor

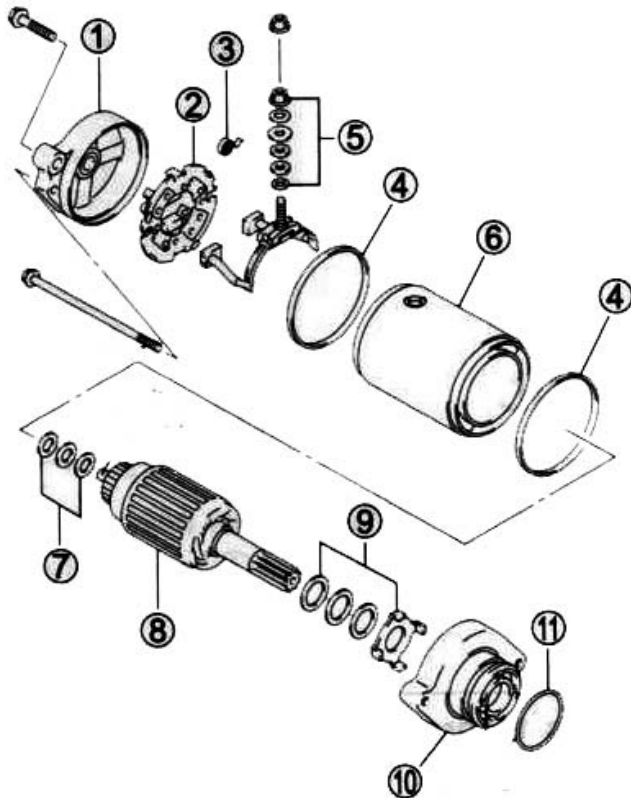

- ① Bracket
- ② Brush Seat
- ③ Brush Spring
- ④ O-ring
- ⑤ Shims
- ⑥ Motor Housing
- ⑦ Washers
- ⑧ Armature Coil
- ⑨ Washer Kit
- ⑩ Inner Bracket
- ⑪ O-ring

Brushes

- Check brushes for abnormal wear, cracks or smoothness in the brush holder.

Wear, cracks or non-smoothness: → Replace



Commutator

- Check Commutator for discoloration, abnormal wear or undercut.

Abnormal wear or Damage: → Replace

- If the commutator is discolored, polish with a sand paper and clean with a clean and dry cloth.
- If there is undercut, scrape out insulator B and make its distance between A as d

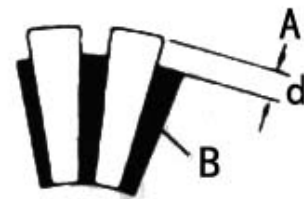

$d \geq 1.5\text{mm}$

Armature Coil

- Check for continuity between each segment and between each segment and armature shaft using a multimeter.
- If there is no continuity between the segments or there is continuity between segments and shaft, replace the armature with a new one.

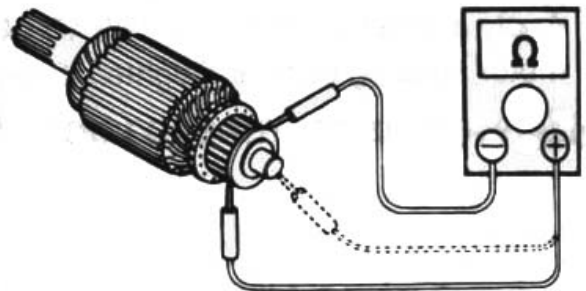

Oil Seal

- Check Oil Seal Lip for damage or leakage.
Damage or leakage: → Replace with a new starting motor

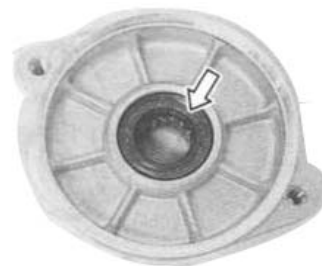

Starter Relay

- Apply 12V to the terminals and check for continuity between the positive and negative terminals using a multimeter.
- If the starter relay clicks and continuity is found, the starter relay is OK.
- If there is no continuity when without the 12V, the relay is OK.

Note: Do not apply the battery voltage to the starter relay for more than 2 seconds. This may cause overheat and damage the relay coil.

- Measure the coil resistance between the terminals using a multimeter. If the resistance is out of the specified value, replace the starter relay with a new one.

Set multimeter to 1x10Ω position

Starter relay coil resistance: 3-5Ω

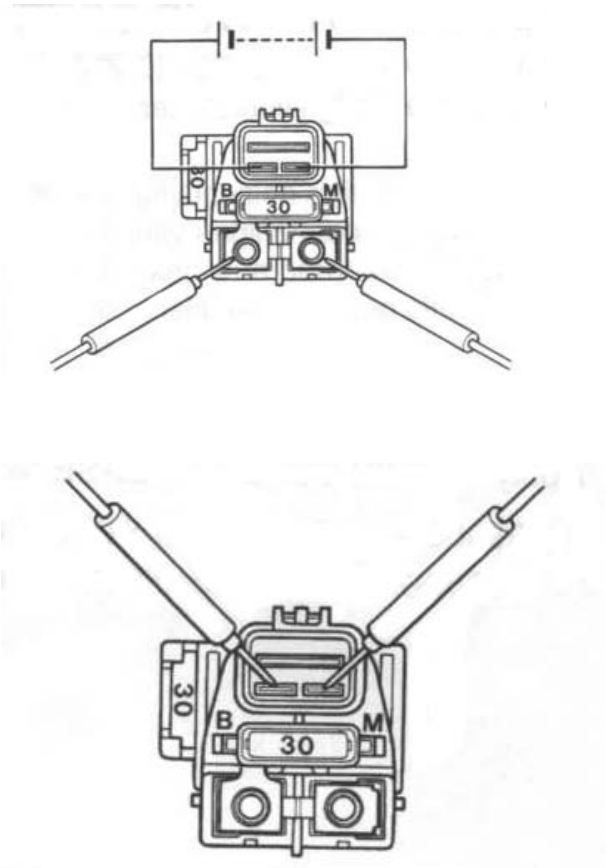

Auxiliary Starter Relay

- Apply 12V to starter relay positive and negative terminals and check for continuity between A and B using a multimeter.
- If the starter relay clicks and continuity is found, the starter relay is OK.
- If there is no continuity when without the 12V, the relay is OK.

Set multimeter to 1x100Ω position

Auxiliary starter relay coil resistance: 90-100Ω

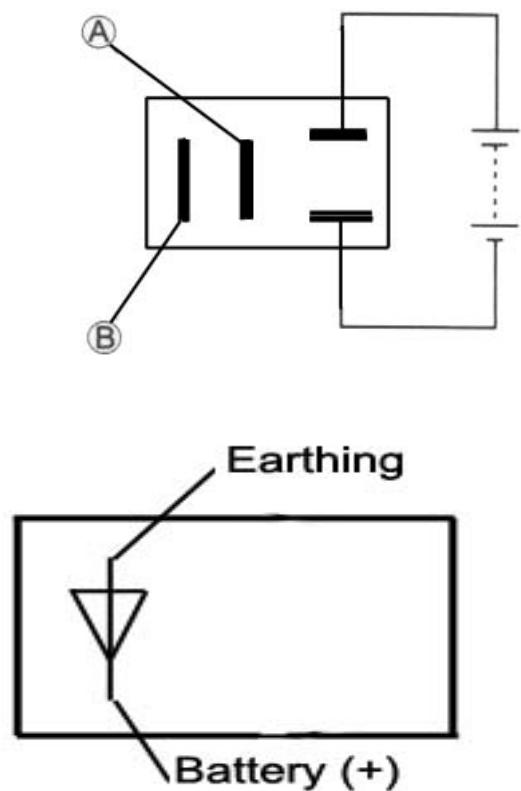

Ignition System

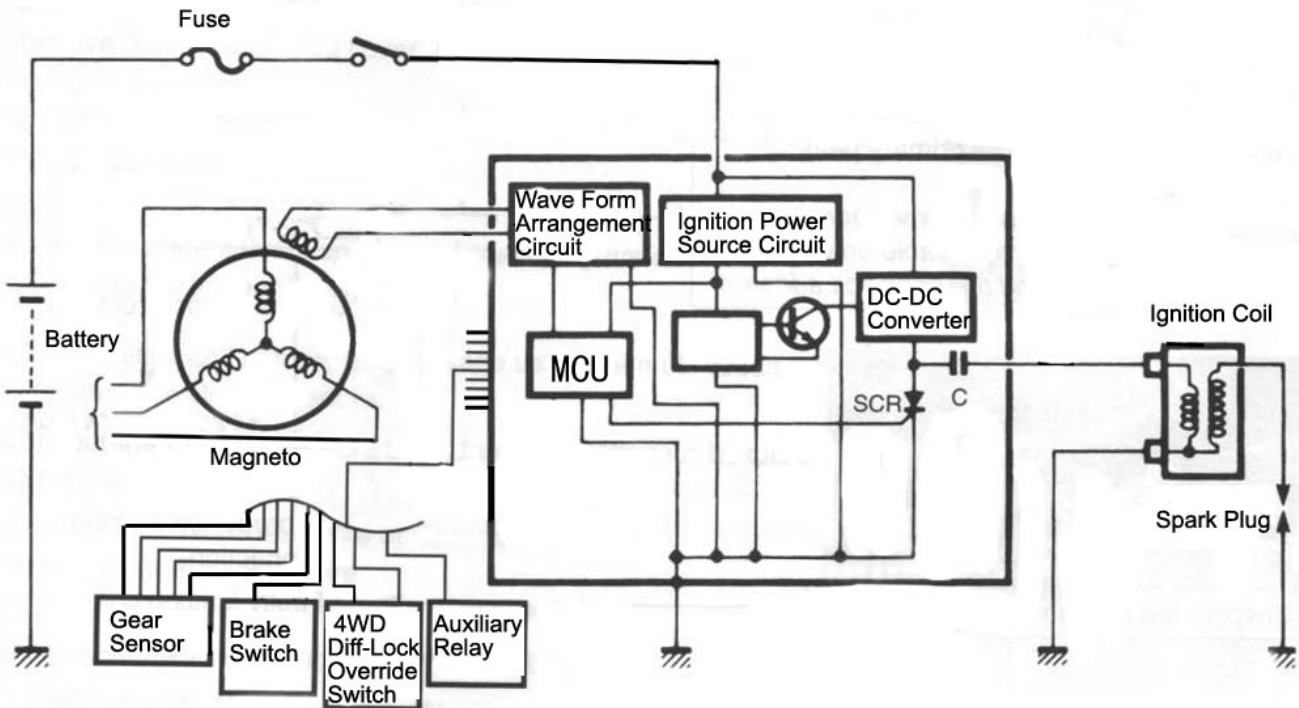

Ignition Coil

Ignition Coil Primary Peak Voltage

- Remove spark plug cap, install a new spark plug into cap and connect as illustrated on the right with cylinder head as ground.
- Connect multimeter and peak voltage adaptor as under:

+Probe: Green lead wire or Ground

-Probe: Black/Yellow lead wire

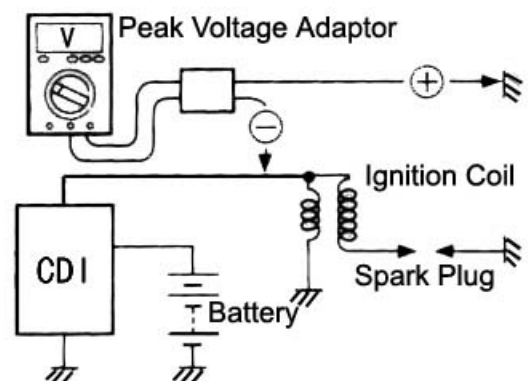

Note:

- Make sure battery voltage $\geq 12V$, ignition coil lead wire is connected.
- Refer to user's manual when using multimeter and peak voltage adaptor.

- Shift the gear to neutral position and turn the ignition switch to the "ON" position;
- Press the starter button and crank the engine several seconds, then measure the ignition coil primary peak voltage;
- Repeat above steps several times and take the measured highest ignition coil primary peak voltage.

Set the multimeter to AC position

Ignition Coil Primary Peak Voltage: $\geq 150V$

Caution: Do not touch the tester probes or the spark plug to avoid electric shock.

- If the voltage is lower than the standard value, check ignition coil and pick-up coil.

Ignition Coil Resistance

- Disconnect ignition coil lead wire and spark plug cap. Remove ignition coil;
- Measure the ignition coil resistance in both primary and secondary windings using the multimeter. If both the primary and secondary windings are close to the specified value, the ignition coil is in good condition.

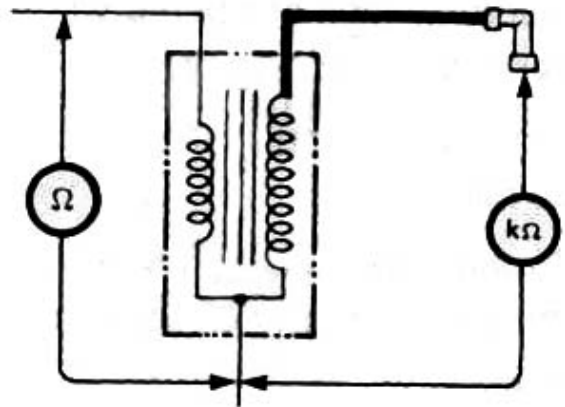
**Ignition Coil Resistance**

Primary: 0.1-1.5 Ω (Terminal—Ground)

Secondary: 12-22K Ω (Terminal—Spark Plug Cap)

Pickup Coil Peak Voltage

- Measure the pickup coil peak voltage in the following steps:
- Connect multimeter and peak voltage adaptor as illustrated on the right;

+Probe: Green lead wire

-Probe: Blue lead wire

- Shift the gear to neutral position and turn the ignition switch to the "ON" position;
- Press the starter button and crank the engine several seconds, then measure the pickup coil primary peak voltage;
- Repeat above steps several times and take the measured highest pickup coil peak voltage.

Set the multimeter to AC V position

Pickup Coil Peak Voltage: $\geq 4V$

- If the voltage is lower than the standard value, replace the pickup coil

Pickup Coil Resistance

Set the multimeter to $1 \times 100\Omega$ position

Pickup Coil Resistance: 120-130 Ω

- Replace the pickup coil if the resistance is not within the value.

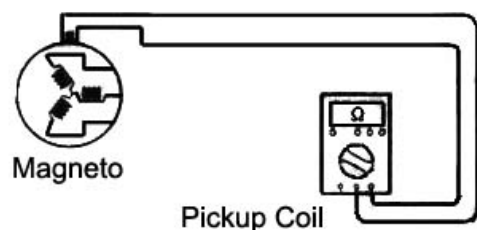
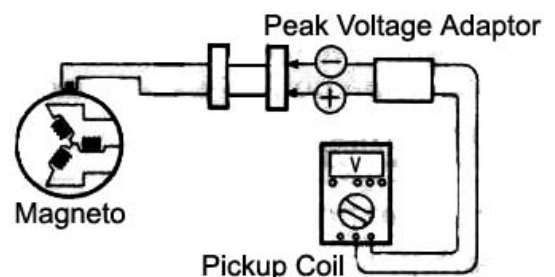

1. Engine

Complaint	Symptom and Possible Causes	Remedy
<p>Engine will not start or is hard to start</p>	<p>Compression is Too Low</p> <ol style="list-style-type: none"> 1. Worn cylinder 2. Worn piston ring 3. Leakage with cylinder gasket Wear valve guide or improper valve seating 4. Loose spark plug 5. Slow cranking of starting motor 6. Faulty valve timing 7. Improper valve clearance <p>No Sparking from Spark Plug</p> <ol style="list-style-type: none"> 1. Fouled spark plug 2. Wet spark plug 3. Defective ignition coil 4. Open or short circuit with pickup coil 5. Faulty generator 6. Faulty CDI <p>No Fuel Reach Into Carburetor</p> <ol style="list-style-type: none"> 1. Clogged fuel tank vent tube 2. Clogged or faulty fuel valve 3. Faulty carburetor needle valve 4. Clogged fuel hose 5. Clogged fuel filter <p>Transfer is not in Neutral position</p>	<p>Replace</p> <p>Replace</p> <p>Replace</p> <p>Repair or Replace</p> <p>Tighten</p> <p>Check electrical part</p> <p>Adjust</p> <p>Adjust</p> <p>Clean or Replace</p> <p>Clean and dry or replace</p> <p>Replace</p> <p>Replace</p> <p>Replace</p> <p>Replace</p> <p>Clean or Replace</p> <p>Clean or Replace</p> <p>Replace</p> <p>Replace</p> <p>Clean or Replace</p> <p>Set to Neutral position</p>
<p>Engine stalls easily or has unstable idle speed</p>	<ol style="list-style-type: none"> 1. Improper valve clearance 2. Improper valve seating 3. Faulty valve guide 4. Worn rocker arm or rocker arm shaft 5. Fouled spark plug 6. Improper spark plug gap 7. Faulty ignition coil 8. Faulty CDI 9. Faulty generator 10. Improper fuel level in float chamber 11. Clogged carburetor jet 12. Faulty fuel valve 13. Improper adjustment or idle screw 	<p>Adjust</p> <p>Replace or Correct</p> <p>Replace</p> <p>Replace</p> <p>Replace</p> <p>Replace or Adjust</p> <p>Replace</p> <p>Replace</p> <p>Replace</p> <p>Adjust Fuel level</p> <p>Clean</p> <p>Replace</p> <p>Adjust</p>

Complaint	Symptom and Possible Causes	Remedy
Poor engine running in high-speed range.	<ol style="list-style-type: none"> 1. Weak valve spring 2. Worn camshaft 3. Fouled spark plug 4. Insufficient spark plug gap 5. Improper valve timing 6. Faulty ignition coil 7. Low fuel level in float chamber 8. Dirty air filter 9. Clogged fuel hose, resulting in poor fuel supply 10. Clogged fuel valve 	<p>Replace</p> <p>Replace</p> <p>Clean or replace</p> <p>Adjust or replace</p> <p>Replace</p> <p>Adjust float chamber fuel level</p> <p>Clean or replace</p> <p>Clean</p> <p>Clean</p> <p>Clean</p>
Exhaust smoke is dirty or thick	<ol style="list-style-type: none"> 1. Excessive engine oil 2. Worn piston ring 3. Worn valve guide 4. Scored or scuffed cylinder wall 5. Worn valve stem 6. Worn valve stem oil seal 	<p>Check oil level and drain</p> <p>Replace</p> <p>Replace</p> <p>Replace</p> <p>Replace</p> <p>Replace</p>
Engine lacks power	<ol style="list-style-type: none"> 1. Improper valve clearance 2. Weak valve spring 3. Improper valve timing 4. Worn cylinder 5. Worn piston ring 6. Improper valve seating 7. Fouled spark plug 8. Improper spark plug gap 9. Clogged carburetor jet 10. Improper fuel level in fuel chamber 11. Dirty air filter 12. Worn rocker arm or rocker arm shaft 13. Air leakage from air intake pipe 14. Excessive engine oil 	<p>Adjust</p> <p>Adjust</p> <p>Adjust</p> <p>Replace</p> <p>Replace</p> <p>Replace or Correct</p> <p>Clean or replace</p> <p>Clean or replace</p> <p>Clean or replace</p> <p>Adjust fuel level</p> <p>Clean or replace</p> <p>Replace</p> <p>Tighten or replace</p> <p>Check oil level and drain</p>
Engine overheats	<ol style="list-style-type: none"> 1. Carbon deposit on piston top 2. Insufficient or excessive engine oil 3. Faulty oil pump 4. Clogged oil passage 5. Fuel level in float chamber is too low 6. Air leakage from air intake pipe 7. Incorrect engine oil 8. Faulty cooling system (→16-5) 	<p>Clean</p> <p>Check level, add or drain</p> <p>Replace</p> <p>Clean</p> <p>Adjust fuel level</p> <p>Tighten or replace</p> <p>Change engine oil</p>

Complaint	Symptom and Possible Causes	Remedy
Engine is noisy	Valve Chatter <ol style="list-style-type: none"> 1. Excessive valve clearance 2. Worn or broken valve spring 3. Worn rocker arm or camshaft 	Replace Replace Replace
	Noise from Piston <ol style="list-style-type: none"> 1. Worn piston 2. Worn cylinder 3. Carbon deposit in combustion chamber 4. Worn piston pin or pin hole 5. Worn piston ring or piston ring groove 	Replace Replace Clean Replace Replace
	Noise from Timing chain <ol style="list-style-type: none"> 1. Stretched chain 2. Worn sprocket wheel 3. Faulty chain tensioner 	Replace chain & sprocket Replace chain & sprocket Repair or replace
	Noise from Clutch <ol style="list-style-type: none"> 1. Worn or damaged crankshaft spline 2. Worn inner race spline 	Replace crankshaft Replace inner race
	Noise from Crankshaft <ol style="list-style-type: none"> 1. Rattling bearing 2. Worn or burnt crank pin bearing 3. Excessive thrust clearance 	Replace Replace Replace
	Noise from CVT <ol style="list-style-type: none"> 1. Worn or slipping drive belt 2. Worn rollers in primary sheave 	Replace Replace
	Noise from Transmission <ol style="list-style-type: none"> 1. Worn or damaged gear 2. Worn or damaged input or output shafts 3. Worn bearing 4. Worn bushing 	Replace Replace Replace Replace
Slipping Clutch	<ol style="list-style-type: none"> 1. Worn or damaged clutch shoes 2. Weakened clutch shoe spring 3. Worn clutch housing 4. Worn or slipping drive belt 	Replace Replace Replace REplace

Complaint	Symptom and Possible Causes	Remedy
Difficulty or locked gearshift	<ol style="list-style-type: none"> 1. Broken drive or driven bevel gear teeth 2. Distorted shift fork 3. Worn shift cam 4. Improper gearshift rod 	Replace Replace Replace Adjust

2. Carburetor

Complaint	Symptom and Possible Causes	Remedy
Starting Difficulty	<ol style="list-style-type: none"> 1. Clogged starter jet 2. Clogged starter jet passage 3. Air leakage from joint between starter body and carburetor 4. Faulty starting plunger 	Clean Clean Clean, adjust or replace gasket Adjust
Idling or low-speed trouble	<ol style="list-style-type: none"> 1. Clogged slow jet 2. Clogged slow jet passage 3. Clogged air intake 4. Clogged bypass port 5. Starter plunger not fully closed 6. Improper set of idle screw 7. Improper float height 	Clean Clean Clean Clean Adjust Adjust Adjust
Medium or high speed trouble	<ol style="list-style-type: none"> 1. Clogged main jet 2. Clogged main air jet 3. Clogged needle jet 4. Faulty throttle valve 5. Clogged fuel filter 6. Improper float height 7. Starter plunger not fully closed 	Clean Clean Clean Adjust Clean Adjust Adjust
Overflow and fuel level fluctuation	<ol style="list-style-type: none"> 1. Worn or damaged needle valve 2. Damaged needle valve spring 3. Improper working float 4. Foreign matter in needle valve 	Replace Replace Adjust or Replace Clean

3. Cooling System/Radiator

Complaint	Symptom and Possible Causes	Remedy
Engine overheats	<ol style="list-style-type: none"> 1. Clogged water passage or radiator 2. Air in the cooling system; insufficient coolant 3. Faulty water pump 4. Incorrect coolant 5. Faulty thermostat 6. Faulty fan motor or thermostwitch 	Clean Discharge air and add coolant Check and replace Replace Replace Check and/or replace
Engine coolant overcools	<ol style="list-style-type: none"> 1. Faulty thermostwitch 2. Extremely cold weather 3. Faulty thermostat 	Replace Put on radiator cover Replace

4. Ignition System

Complaint	Symptom and Possible Causes	Remedy
No Sparking or Weak Sparking	<ol style="list-style-type: none"> 1. Faulty CDI 2. Faulty spark plug 3. Faulty Generator 4. Insufficient battery voltage 5. Faulty ignition coil 6. Faulty pickup coil 	Check and replace Check and replace Check and replace Check and replace Check and replace Check and replace