



POLARIS®

2017
RANGER® 570

Owner's Manual
for Maintenance and Safety



***For videos and more information
about a safe riding experience with
your Polaris vehicle, scan this QR
code with your smartphone.***

WELCOME

Thank you for purchasing a POLARIS vehicle, and welcome to our world-wide family of POLARIS enthusiasts. Be sure to visit us online at www.polaris.com for the latest news, new product introductions, upcoming events, career opportunities and more.

Here at POLARIS we proudly produce an exciting line of utility and recreational products.

- Snowmobiles
- All-terrain vehicles (ATVs)
- Low emission vehicles (LEVs)
- *RANGER*® utility vehicles
- BRUTUS® work vehicles
- SLINGSHOT® three wheel motorcycles
- *RZR*® sport vehicles
- GEM® electric vehicles
- VICTORY® motorcycles
- INDIAN® motorcycles
- POLARIS POWER® generators
- POLARIS DEFENSE® combat vehicles

Always follow the instructions and recommendations in this manual. The manual contains instructions for minor maintenance, but information about major repairs is outlined in the POLARIS Service Manual and should be performed only by a factory-certified Master Service Dealer® (MSD) technician. Please see your dealer for all of your service needs during (and after) the warranty period.



POLARIS® and *RANGER*® are trademarks of POLARIS Industries Inc.

Copyright 2016 POLARIS Industries Inc. All information contained within this publication is based on the latest product information at the time of publication. Due to constant improvements in the design and quality of production components, some minor discrepancies may result between the actual vehicle and the information presented in this publication. Depictions and/or procedures in this publication are intended for reference use only. No liability can be accepted for omissions or inaccuracies. Any reprinting or reuse of the depictions and/or procedures contained within, whether whole or in part, is expressly prohibited.

The original instructions for this vehicle are in English. Other languages are provided as translations of the original instructions.

2017 *RANGER* 570 MD / *RANGER* 570 EPS Owner's Manual

P/N 9927385

TABLE OF CONTENTS

Introduction	4
Safety	8
Features and Controls	21
Operation	37
Winch Guide	52
Emission Control Systems	60
Maintenance	61
Specifications	90
POLARIS Products	92
Troubleshooting	93
Warranty	96
Maintenance Log	99
Index	100

INTRODUCTION

The *RANGER* is an off-road vehicle. Familiarize yourself with all laws and regulations concerning the operation of this vehicle in your area.

The following signal words and symbols appear throughout this manual and on your vehicle. Your safety is involved when these words and symbols are used. Become familiar with their meanings before reading the manual.



The safety alert symbol indicates a potential personal injury hazard.

DANGER

A **DANGER** indicates a hazardous situation that, if not avoided, will result in death or serious injury.

WARNING

A **WARNING** indicates a hazardous situation that, if not avoided, could result in death or serious injury.

CAUTION

A **CAUTION** indicates a hazardous situation that, if not avoided, could result in minor or moderate injury.

NOTICE

A **NOTICE** indicates a situation that could result in property damage.



The Prohibition Safety Sign indicates an action **NOT** to take in order to avoid a hazard.



The Mandatory Action Sign indicates an action that **NEEDS** to be taken to avoid a hazard.

Declaration of Conformity

Polaris Sales Europe Sàrl
Route de l'Etraz
Business Center A5
1180 Rolle, Switzerland
Telephone +41213-218-700



DECLARATION OF CONFORMITY

July 17, 2016

Polaris Sales Europe Sàrl declares that the vehicle(s) listed below conform to the essential requirements applicable to all terrain vehicles.

APPLICABLE EUROPEAN DIRECTIVES:	TEST / EVALUATION METHODS:
2006/42/EC as amended (Machinery Directive)	EN ISO 12100:2010 Hazard Analysis EN 15997:2011/AC:2012 Driver Perceived Noise & Vibration Level
2014/30/EU as amended (EMC Directive)	UNECE R10

MODEL	COMMERCIAL NAME	SERIAL NUMBER
R_ _RM_ _57_ _ (All combinations)	RANGER 570	(See Product Identification Label)

INTRODUCTION

Vehicle Identification Numbers

Record your vehicle's identification numbers and key number in the spaces provided. Remove the spare key and store it in a safe place. An ignition key can be duplicated only by ordering a POLARIS key blank (using your key number) and mating it with one of your existing keys. The ignition switch must be replaced if all keys are lost.



VIN
(stamped into main frame)



Key
Number

Vehicle Model Number: _____

Frame VIN: _____

Engine Serial Number: _____

Key Number: _____

⚠ WARNING

Failure to heed the warnings and safety precautions contained in this manual can result in severe injury or death. Your POLARIS vehicle is not a toy and can be hazardous to operate. This vehicle handles differently than cars, trucks or other off-road vehicles. A collision or rollover can occur quickly, even during routine maneuvers like turning, or driving on hills or over obstacles, if you fail to take proper precautions.

- Read this owner's manual and review the safety DVD that came with your vehicle. A free extra copy of the DVD can be obtained by contacting your local POLARIS dealer. Understand all safety warnings, precautions and operating procedures before operating the vehicle. Keep this manual with the vehicle.
- Never operate this vehicle without proper instruction. Take an authorized training course.
- This vehicle is an **ADULT VEHICLE ONLY**. You **MUST** be at least age 16 and have a valid driver's license to operate this vehicle.
- No person under the age of 12 may ride as a passenger in this vehicle. All riders must be able to sit with backs against the seat, both feet flat on the floor and both hands on the steering wheel (if driving) or on a passenger hand hold.
- Never permit a guest to operate this vehicle unless the guest has read this manual and all product labels.
- Always use the cab nets (or doors) while riding in this vehicle. Always keep hands, feet and all other body parts inside the vehicle at all times.
- Always wear a helmet, eye protection, gloves, long-sleeve shirt, long pants and over-the-ankle boots.
- Never use this vehicle with drugs or alcohol, as these conditions impair judgment and reduce operator reaction time.

Safety Training

Safety training is a top priority for POLARIS. POLARIS strongly encourages you and any family members who will be riding this vehicle to take a training course.

For more information about safety, contact an authorized POLARIS dealer or visit the POLARIS web site at www.polaris.com.

Your POLARIS vehicle is considered an off-road vehicle. Familiarize yourself with all laws and regulations concerning the operation of this vehicle in your area.

We strongly advise you to strictly follow the recommended maintenance program outlined in your owner's manual. This preventive maintenance program is designed to ensure that all critical components on your vehicle are thoroughly inspected at specific intervals.

SAFETY

Safe Riding Gear

The driver and all passengers must wear helmet, eye protection, gloves, long-sleeve shirt, long pants, over-the-ankle boots and seat belt at all times. Protective gear reduces the chance of injury.

Helmet

Wearing a helmet can prevent a severe head injury. Whenever riding this POLARIS vehicle, always wear a helmet that meets or exceeds established safety standards.

Approved helmets in Europe, Asia and Oceania bear the ECE 22.05 label. The ECE mark consists of a circle surrounding the letter E, followed by the distinguishing number of the country which has granted approval. The approval number and serial number will also be displayed on the label.

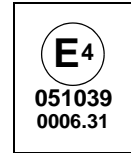

Safe Riding Gear

Eye Protection

Do not depend on eyeglasses or sunglasses for eye protection. Whenever riding this POLARIS vehicle, always wear shatterproof goggles or use a shatterproof helmet face shield. POLARIS recommends wearing approved Personal Protective Equipment (PPE) bearing markings such as VESC 8, V-8, Z87.1, or CE. Make sure protective eye wear is kept clean.

Gloves

Wear gloves for comfort and for protection from sun, cold weather and other elements.

Boots

Wear sturdy over-the-ankle boots for support and protection. Never ride a POLARIS vehicle with bare feet or sandals.

Clothing

Wear long sleeves and long pants to protect arms and legs.

Rider Comfort

Under certain operating conditions, heat generated by the engine and exhaust system can elevate temperatures in the driver and passenger cab area. The condition occurs most frequently when a vehicle is being operated in high ambient temperatures at low speeds and/or high load conditions for an extended period of time. The use of certain windshield, roof and/or cab systems may contribute to this condition by restricting airflow. Any discomfort due to heat buildup in this area can be minimized by wearing proper riding apparel and by varying speeds to increase airflow.

SAFETY

Safety Labels and Locations

Warning labels have been placed on the vehicle for your protection. Read and follow the instructions of the labels on the vehicle carefully. If any of the labels depicted in this manual differ from the labels on your vehicle, always read and follow the instructions of the labels *on the vehicle*.

If any label becomes illegible or comes off, contact your POLARIS dealer to purchase a replacement. Replacement *safety* labels are provided by POLARIS at no charge. The part number is printed on the label.

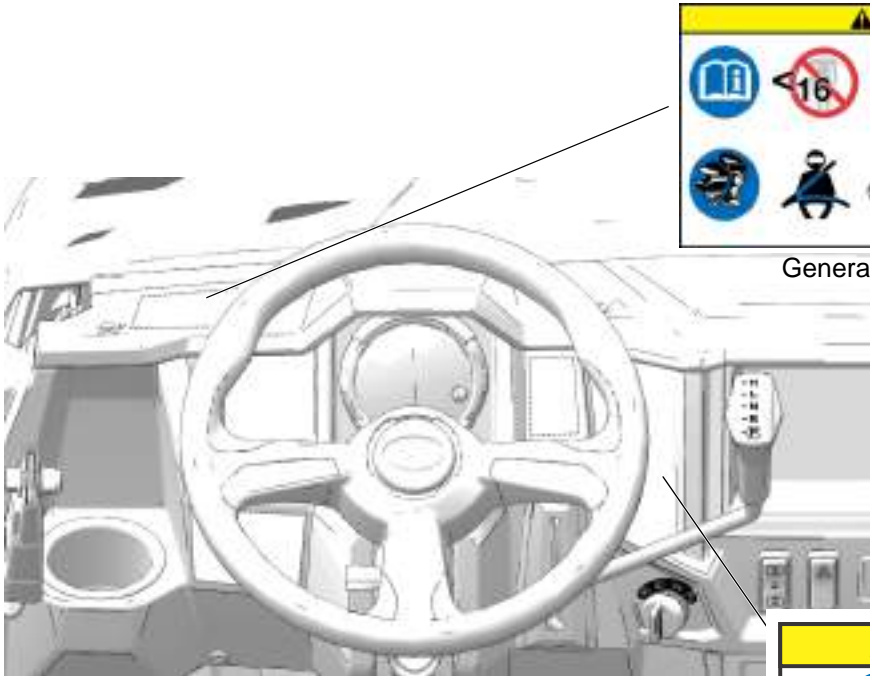

General Alert

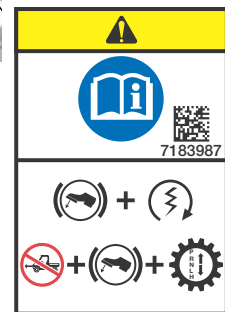

Shift Alert

General Alert (7183794)

Read the owner's manual. Never allow anyone under 16 years of age to operate this vehicle. Never use alcohol or drugs before or while driving or riding. Do not allow operation on public roads (unless designated for off-highway vehicle access). Wear approved helmet, goggles, and protective clothing. Always wear seat belts. Always use the cab nets or doors. Never exceed seating capacity.

Shift Alert (7183987)

CAUTION

To avoid transmission damage, shift only when vehicle is stationary and at idle.

APPLY BRAKE TO START. When this vehicle is not in operation, or unattended, place shift in the park position.

SAFETY

Safety Labels and Locations



Load/Passenger/Tire Pressure Alert

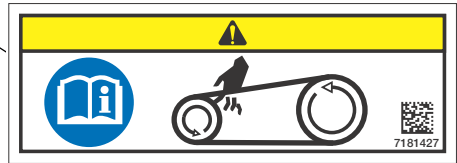

Clutch Cover Alert

Load/Passenger/Tire Pressure Alert (7183795)

Never carry passengers in cargo box. Passengers can be thrown off. This can cause serious injury or death. Read owner's manual. Always use an approved fuel container for transporting fuel.

RANGER MIDSIZE	RANGER MIDSIZE
MAXIMUM CARGO BOX LOAD	226 kg
TIRE PRESSURE IN KPa/bar	FRONT 69/0,69 REAR 69/0,69
MAXIMUM WEIGHT CAPACITY INCLUDES WEIGHT OF OPERATOR, PASSENGER, CARGO AND ACCESSORIES	454 kg
Read Operation & Maintenance Manual for more detailed loading information.	

Clutch Cover Alert (7181427)

Keep body parts away from belt. Read owner's manual.

Operator Safety

⚠ WARNING

Serious injury or death can result if you do not follow these instructions and procedures, which are outlined in further detail within your owner's manual.

- Read this entire manual and all labels carefully. Follow the operating procedures described.
- Never allow anyone under the age of 16 to operate this vehicle and never allow anyone without a valid driver's license to operate this vehicle.
- Do not carry a passenger until you have at least two hours of driving experience with this vehicle.
- No person under the age of 12 may ride as a passenger in this vehicle. All riders must be able to sit with backs against the seat, both feet flat on the floor and both hands on the steering wheel (if driving) or on a passenger hand hold.
- The driver and all passengers must wear helmet, eye protection, gloves, long-sleeve shirt, long pants, over-the-ankle boots and seat belt at all times.
- Always use the cab nets (or doors) while riding in this vehicle.
- Always keep hands and feet inside the vehicle at all times.
- Always keep both hands on the steering wheel and both feet on the floorboards of the vehicle during operation.
- Never permit a guest to operate this vehicle unless the guest has read this manual and all product labels.
- To reduce rollover risk, be especially careful when encountering obstacles and slopes and when braking on hills or during turns.
- This vehicle is for off road use only. Never operate on public roads (unless marked for off-road use). Always avoid paved surfaces.
- Never consume alcohol or drugs before or while operating this vehicle.
- Never operate at excessive speeds. Always travel at a speed proper for the terrain, visibility and operating conditions, and your experience.
- Never attempt jumps or other stunts.
- Always inspect the vehicle before each use to make sure it's in safe operating condition. Always follow the inspection procedures described in this manual.

SAFETY

Operator Safety

- Always travel slowly and use extra caution when operating on unfamiliar terrain. Be alert to changing terrain.
- Never operate on excessively rough, slippery or loose terrain.
- Always follow proper procedures for turning. Practice turning at slow speeds before attempting to turn at faster speeds. Never turn at excessive speeds.
- Always have this vehicle checked by an authorized POLARIS dealer if it has been involved in an accident.
- Never operate this vehicle on hills too steep for the vehicle or for your abilities. Practice on smaller hills before attempting larger hills.
- Always follow proper procedures for climbing hills as described in this manual. See page 42. Check the terrain carefully before attempting to climb a hill. Never climb hills with excessively slippery or loose surfaces. Never apply throttle suddenly. Never make sudden gear changes. Never go over the top of a hill at high speed.
- Always follow the proper procedures outlined in this manual for traveling downhill and for braking on hills. See page 42. Check the terrain carefully before descending a hill. Never travel downhill at high speed. Avoid going downhill at an angle, which would cause the vehicle to lean sharply to one side. Travel straight down the hill where possible.
- Always check for obstacles before operating in a new area. Never attempt to operate over large obstacles such as large rocks or fallen trees. Always follow the proper procedures outlined in this manual when operating over obstacles. See page 41.
- Always be careful of skidding or sliding. On slippery surfaces such as ice, travel slowly and exercise caution to reduce the chance of skidding or sliding out of control.
- Never operate your vehicle in fast-flowing water or in water deeper than that specified in this manual. See page 44. Wet brakes may have reduced stopping ability. Test your brakes after leaving water. If necessary, apply them lightly several times to let friction dry out the pads.
- Always be sure there are no obstacles or people behind your vehicle when operating in reverse. When it's safe to proceed in reverse, move slowly. Avoid turning at sharp angles in reverse.

Operator Safety

- Always use the proper size and type of tires specified in this manual. Always maintain proper tire pressure as specified on safety labels.
- Never modify this vehicle through improper installation or use of non-POLARIS approved accessories.
- Never exceed the stated load capacity for this vehicle. Cargo should be properly distributed and securely attached. Reduce speed and follow the instructions in this manual for hauling cargo or pulling a trailer. Allow a greater distance for braking.
- Always place the transmission in PARK before getting out of the vehicle.
- Always engage the park brake when leaving the vehicle unattended.
- Always stop the engine before refueling. Remove flammable material containers from the box before filling them with fuel. Make sure the refueling area is well ventilated and free of any source of flame or sparks. Gasoline is extremely flammable. See page 20 for fuel safety warnings.
- Always remove the ignition key when the vehicle is not in use to prevent unauthorized use by someone under the age of 16 or without a driver's license and proper training, or accidental starting.

For more information about safety, contact an authorized POLARIS dealer or visit the POLARIS web site at www.polaris.com.

Equipment Modifications

Do not install any non-POLARIS approved accessory or modify the vehicle for the purpose of increasing speed or power. Any modifications or installation of non-POLARIS approved accessories could create a substantial safety hazard and increase the risk of bodily injury.

The warranty on your POLARIS vehicle will be terminated if any non-POLARIS approved equipment and/or modifications have been added to the vehicle that increase speed or power.

The addition of certain accessories, including (but not limited to) mowers, blades, tires, sprayers, or large racks, may change the handling characteristics of the vehicle. Use only POLARIS-approved accessories, and familiarize yourself with their function and effect on the vehicle.

SAFETY

Operator Safety

⚠ WARNING

Failure to operate the *RANGER* properly can result in a collision, loss of control, accident or rollover, which may result in serious injury or death. Heed all safety warnings outlined in this section of the owner's manual. See the OPERATION section of the owner's manual for proper operating procedures.



Operating Without Instruction

Operating this vehicle without proper instruction increases the risk of an accident. The operator must understand how to operate the vehicle properly in different situations and on different types of terrain.

All operators must read and understand the Owner's Manual and all warning and instruction labels before operating the vehicle.



Age Restrictions

This vehicle is an **ADULT VEHICLE ONLY**. NEVER operate this vehicle if you are under age 16 and NEVER operate without a valid driver's license.

Never operate with a passenger under the age of 12. All riders must be able to sit with backs against the seat, both feet flat on the floor and both hands on the steering wheel (if driving) or on a passenger hand hold.



Using Alcohol or Drugs

Operating the vehicle after consuming alcohol or drugs could adversely affect operator judgment, reaction time, balance and perception.

Never drink alcohol or use drugs or medications before or while operating this vehicle.



Operator Safety

Seat Belts

Riding in this vehicle without wearing the seat belt increases the risk of serious injury in the event of rollover, loss of control, other accident or sudden stop. Seat belts may reduce the severity of injury in these circumstances.

All riders *must* wear seat belts at all times.



Protective Apparel

Riding in this vehicle without wearing an approved helmet and protective eyewear increases the risk of a serious injuries in the event of an accident.

Operator and all passenger *must* always wear an approved helmet that fits properly and eye protection (goggles or face shield).



Jumps and Stunts

Exhibition driving increases the risk of an accident or rollover. **DO NOT** do power slides, "donuts", jumps or other driving stunts. Avoid exhibition driving.



Carrying a Passenger

A passenger must always be seated in a passenger seat with seat belt secured. Carrying more than one passenger in a 2-seat vehicle can affect the operators ability to steer and operate the controls, which increases the risk of loss of control and accident or rollover.

Never carry more than one passenger in a 2-seat vehicle.



SAFETY

Operator Safety

Cab Nets

Riding in this vehicle without using the cab nets (or doors, if equipped) increases the risk of serious injury or death in the event of an accident or rollover. Always use the cab nets (or doors) while riding in this vehicle.

Always keep hands and feet inside the vehicle at all times.

Failure to Inspect Before Operating

Failure to inspect and verify that the vehicle is in safe operating condition before operating increases the risk of an accident. Always perform the pre-ride inspection before each use of your *RANGER* to make sure it's in safe operating condition. See page 38.

Always follow all inspection and maintenance procedures and schedules described in this owner's manual. See page 61.

Operating With a Load on the Vehicle

The weight of both cargo and passengers impacts vehicle operation. For your safety and the safety of others, carefully consider how your vehicle is loaded and how to safely operate the vehicle. Follow the instructions in this manual for loading, tire pressure, gear selection and speed.

- **Do not exceed vehicle weight capacities.** The vehicle's maximum weight capacity is listed in the specifications section of this manual and on a label on the vehicle. When more passenger weight is added, cargo weight may need to be reduced accordingly.
- The recommended tire pressures are listed in the specifications section of this manual and on a label on the vehicle.

Always follow these guidelines:

Under ANY of these conditions:	Do ALL of these steps:
Passenger and/or cargo exceeds half the maximum weight capacity	1. Slow down. 2. Verify tire pressure. 3. Use extra caution when operating.
Operating in rough terrain	
Operating over obstacles	
Climbing an incline	
Towing	

Exposure to Exhaust

Engine exhaust fumes are poisonous and can cause loss of consciousness or death in a short time. Never start the engine or let it run in an enclosed area.

The engine exhaust from this product contains chemicals known to cause cancer, birth defects or other reproductive harm. Operate this vehicle only outdoors or in well-ventilated areas.

Hot Exhaust Systems

Exhaust system components are very hot during and after use of the vehicle. Hot components can cause burns and fire. Do not touch hot exhaust system components. Always keep combustible materials away from the exhaust system. Use caution when traveling through tall grass, especially dry grass, to avoid debris build-up around the exhaust system.

Operator Safety

Improper Tire Maintenance

Operating this vehicle with improper tires or with improper or uneven tire pressure could cause loss of control or accident. Always use the size and type of tires specified for your vehicle. Always maintain proper tire pressure as described in the owner's manual and on safety labels.

Unauthorized Use of the Vehicle

Leaving the keys in the ignition can lead to unauthorized use of the vehicle by someone under the age of 16, without a drivers license, or without proper training. This could result in an accident or rollover. Always remove the ignition key when the vehicle is not in use.

Turning Improperly

Turning improperly could cause loss of traction, loss of control, accident or rollover. Always follow proper procedures for turning as described in this owner's manual. Never turn abruptly or at sharp angles. Never turn at high speeds. Practice turning at slow speeds before attempting to turn at faster speeds.

Improper Hill Climbing

Climbing hills improperly can cause loss of control or vehicle rollover. Always follow proper procedures for climbing hills as described in this owner's manual. See page 42.

Descending Hills Improperly

Improperly descending a hill could cause loss of control or rollover. Always follow proper procedures for traveling down hills as described in this owner's manual. See page 42.

Stalling While Climbing a Hill

Stalling or rolling backwards while climbing a hill could cause a rollover. Always maintain a steady speed when climbing a hill.

If all forward speed is lost:

- Apply the brakes.
- Place the transmission in reverse and slowly allow the vehicle to roll straight downhill while applying light brake pressure to control speed.

If you begin rolling downhill:

- Never apply engine power.
- Apply the brakes gradually until the vehicle is fully stopped.
- Place the transmission in reverse and slowly allow the vehicle to roll straight downhill while applying light brake pressure to control speed.

Operating on Slippery Terrain

Failure to use extra caution when operating on excessively rough, slippery or loose terrain could cause loss of traction, loss of control, accident or rollover. Do not operate on excessively slippery surfaces. Always slow down and use additional caution when operating on slippery surfaces.

Skidding or sliding due to loss of traction can cause loss of control or rollover (if tires regain traction unexpectedly). Always follow proper procedures for operating on slippery surfaces as described in this owner's manual. See page 41.

SAFETY

Operator Safety

Operating on Frozen Bodies of Water

Severe injury or death can result if the vehicle and/or the operator fall through the ice. Never operate the vehicle on a frozen body of water unless you have first verified that the ice is sufficiently thick to support the weight and moving force of the vehicle, you and your passengers, and your cargo, together with any other vehicles in your party.

Always check with local authorities and residents to confirm ice conditions and thickness over your entire route. Vehicle operators assume all risk associated with ice conditions on frozen bodies of water.

Operating a Damaged Vehicle

Operating a damaged vehicle can result in an accident. After any rollover or other accident, have a qualified service dealer inspect the entire machine for possible damage, including (but not limited to) seat belts, rollover protection devices, brakes, throttle and steering systems.

Operating at Excessive Speeds

Operating this vehicle at excessive speeds increases the operator's risk of losing control. Always operate at a speed that's appropriate for the terrain, the visibility and operating conditions, your skills and experience and your passengers' skills and experience.

Operating on Pavement

This vehicle's tires are designed for off-road use only, not for use on pavement. Operating this vehicle on paved surfaces (including sidewalks, paths, parking lots and driveways) may adversely affect the handling of the vehicle and may increase the risk of loss of control and accident or rollover. Avoid operating the vehicle on pavement. If it's unavoidable, travel slowly, travel short distances and avoid sudden turns or stops.

Operating on Public Roads

Operating this vehicle on public streets, roads or highways could result in a collision with another vehicle. Never operate this vehicle on any public street, road or highway, including dirt and gravel roads (unless designated for off-highway use). In some areas it's unlawful to operate this vehicle on public streets, roads and highways.

Operating in Unfamiliar Terrain

Failure to use extra caution when operating on unfamiliar terrain could result in an accident or rollover. Unfamiliar terrain may contain hidden rocks, bumps, or holes that could cause loss of control or rollover. Travel slowly and use extra caution when operating on unfamiliar terrain. Always be alert to changing terrain conditions.

Refueling

Gasoline is highly flammable and explosive under certain conditions.

- Always exercise extreme caution whenever handling gasoline.
- Always turn off the engine when refueling.
- Always refuel outdoors or in a well ventilated area free of any source of flame or sparks.
- Always use an approved gasoline container to store fuel and remove the container from the vehicle before filling to avoid fuel ignition due to electrical static discharge.
- Do not smoke or allow open flames or sparks in or near the area where refueling is performed or where gasoline is stored.
- Do not overfill the tank. Do not fill the tank neck.
- If gasoline spills on your skin or clothing, immediately wash it off with soap and water and change clothing.

FEATURES AND CONTROLS

Vehicle Components

Your vehicle is equipped with cab nets on both sides of the vehicle. Cab nets (or doors, if equipped) must be used by both operator and passengers at all times. Any illustrations without cab nets are only to allow component identification. Always use the cab nets (or doors).

Not all models come with all features. Refer to the specifications section beginning on page 90.

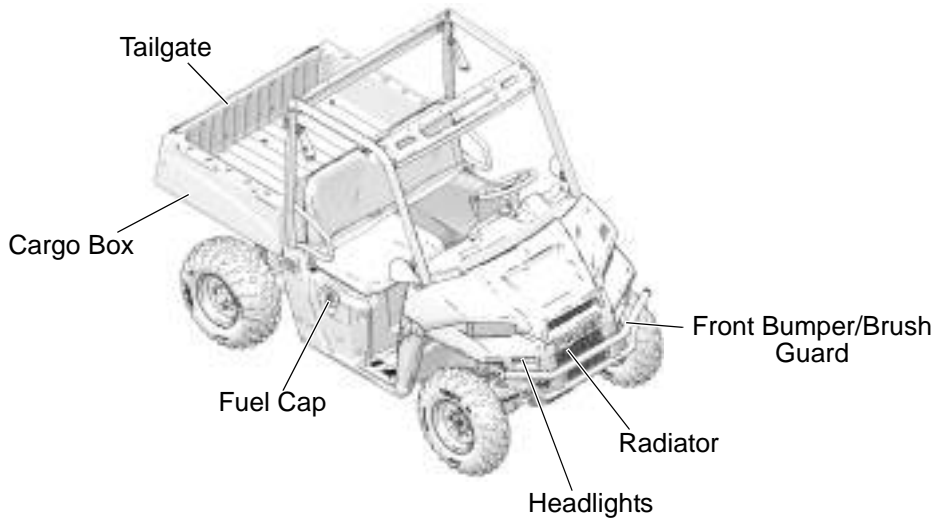
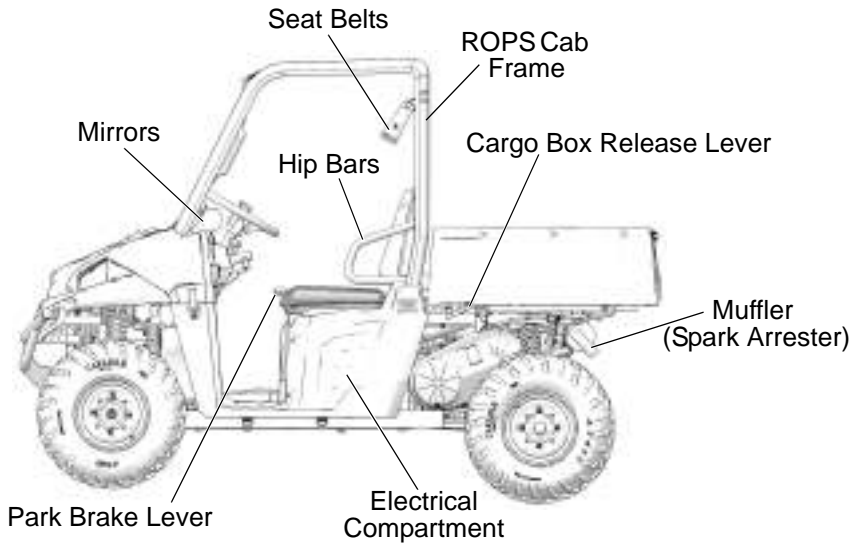

FEATURES AND CONTROLS

Console

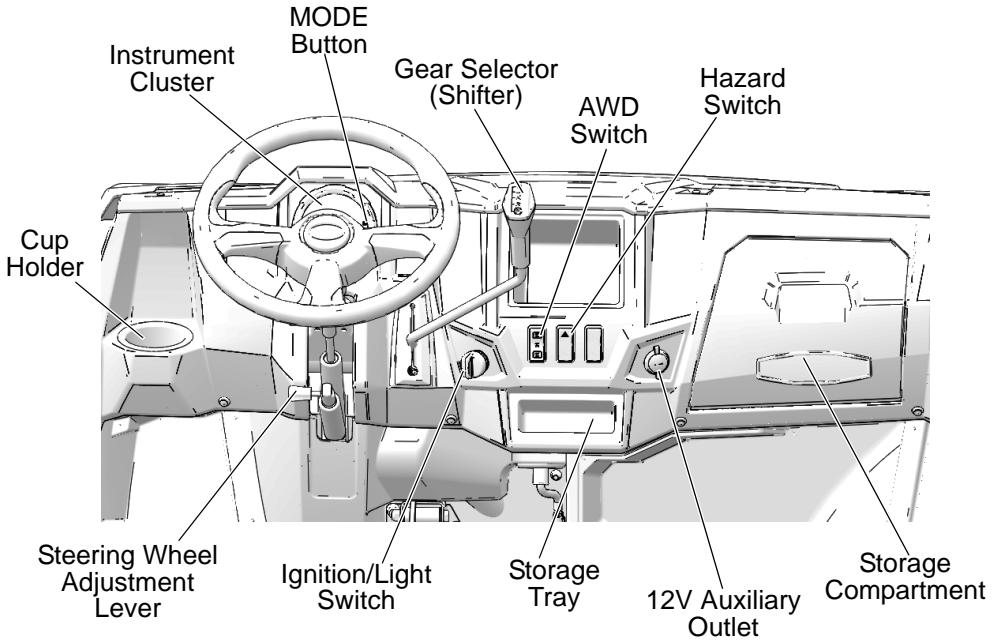

Auxiliary Outlet

The 12-volt receptacle has spade connections on the back that may be used to power an auxiliary light or other optional accessories or lights. The connections are behind the console, under the hood.

Adjustable Steering Wheel

The steering wheel can be tilted upward or downward for rider preference.

Lift and hold the adjustment lever toward you while moving the steering wheel upward or downward. Release the lever when the steering wheel is at the desired position.

Console

Gear Selector

H: High Gear

L: Low Gear

N: Neutral

R: Reverse

P: Park

Low gear is the primary driving range for the *RANGER*. High gear is intended for use on hard-packed surfaces with light loads. Whenever the vehicle is left unattended, always place the transmission in **PARK**.

To change gears, stop the vehicle, and with the engine idling, move the lever to the desired gear. Do not attempt to shift gears with engine speed above idle or while the vehicle is moving.

Tip: Maintaining shift linkage adjustment is important to assure proper transmission function. See your dealer if you experience any shifting problems.

NOTICE: Shifting gears with the engine speed above idle or while the vehicle is moving could cause transmission damage. Always shift when the vehicle is stationary and the engine is at idle.

Using Low Range

Always shift into low gear for any of the following conditions.

- Operating in rough terrain or over obstacles
- Loading the vehicle onto a trailer
- Towing heavy loads



FEATURES AND CONTROLS





Switches

Mode Button

The yellow button located near the instrument cluster is used to toggle through mode options available. See pages 32-36.

Ignition Switch/Light Switch

Use the ignition switch to start the engine and to turn the lights on or off. The key can be removed from the switch when it is in the OFF position.

	OFF	Turn the key to the OFF position to stop the engine. Electrical circuits are off.
	LIGHTS ON	All lights are on. Electrical circuits are on. Electrical equipment can be used.
	POSITION LIGHTS ON	The headlights are off. Position lights are on. Electrical equipment can be used.
	START	Turn the key to the START position to engage the starter. See page 39 for starting procedures.

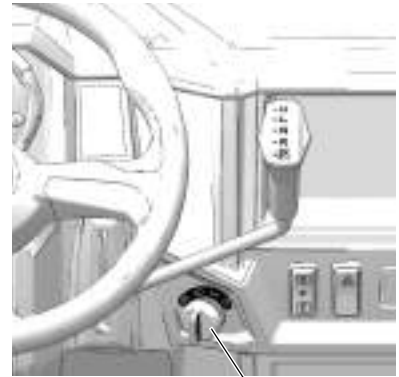

Ignition Switch

High Beam Switch

The headlight high beam is controlled by the turn signal lever. To switch the headlights to high beam, rotate the lever downward. Rotate the lever upward to switch the headlights to low beam.

Horn Switch

The horn switch is located on the turn signal lever. Press the tip of the turn signal lever inward to sound the horn.

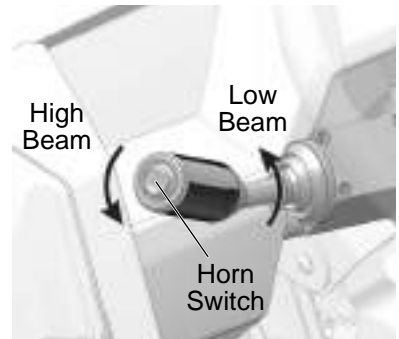

Hazard Switch

Push the hazard warning switch to cause all turn signal lights to flash simultaneously. Both turn signal indicators on the console will also flash. Use this feature to alert others of an emergency or other situation requiring caution.



Switches

Turn Signal Lever

Before turning, activate a turn signal to alert others of your intentions. Check turn signal lamps before each ride.

Tip: The key must be in the ON position to activate the turn signals.

Move the turn signal lever downward to signal a left turn. The left turn signal lamps in the taillight and below the front headlight will flash. The turn signal indicator in the gauge will also flash.

Move the lever upward to signal a right turn. The right signal lamps and indicator will flash.

Return the lever to the center position to end the signal.

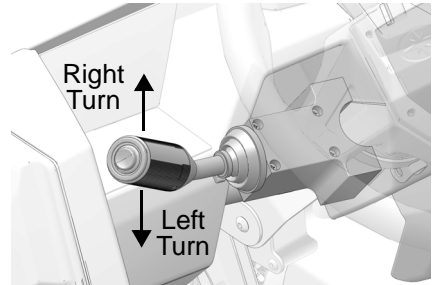

AWD Drive Mode Switch (if equipped)

The AWD Drive Mode switch controls AWD through drive mode options. Press and release the top of the switch to toggle through the drive mode options. The selected drive mode displays in the instrument cluster.

When the switch is released, the drive mode displayed is the active drive mode. See page 49.

Press and release the bottom of the switch to toggle to a previous option.

Drive mode options include:

- ADC - All Wheel Drive (ADC 4X4) (if equipped)
- AWD - All Wheel Drive (AWD/4X4)
- 2WD - Two Wheel Drive (2X4)
- TURF - TURF Mode (1WD)

WARNING! Never operate in TURF mode (if equipped) while operating on a hill or other irregular terrain. Always engage AWD (ADC 4X4 if equipped) before ascending or descending a hill.

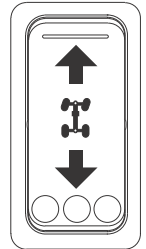

FEATURES AND CONTROLS

Brake Pedal

Depress the brake pedal to slow or stop the vehicle. Apply the brakes while starting the engine.

Throttle Pedal

Push the pedal down to increase engine speed. Spring pressure returns the pedal to the rest position when released. Always check that the throttle pedal returns normally before starting the engine.

This vehicle is equipped with a throttle release switch, which is designed to reduce the risk of a frozen or stuck throttle. If the throttle cable should stick in an open position when the operator releases the throttle pedal, engine speed will be limited, and power to the rear wheels will be reduced.

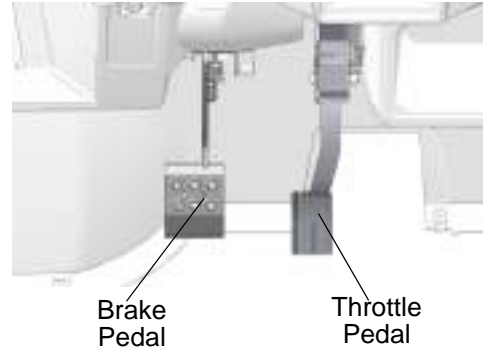

Park Brake Lever

Always apply the service brakes before engaging or releasing the park brake. To help prevent the vehicle from rolling, set the park brake when parking the vehicle. When the park brake is set and the park brake indicator is illuminated, engine speed is limited. If the accelerator is applied, this limiting feature prevents operation, which protects the park brake pads from excessive wear.

Tip: This feature will not operate properly if the park brake connector or switch (under the hood) malfunctions or becomes disconnected, or if the switch has moved. Check for disconnection, then see your dealer promptly if this feature fails to operate properly.

1. To set the park brake, apply the brakes.
2. Pull the park brake lever upward as far as possible.

To release the park brake, apply the brakes. Press the park brake release inward and move the lever downward as far as possible.

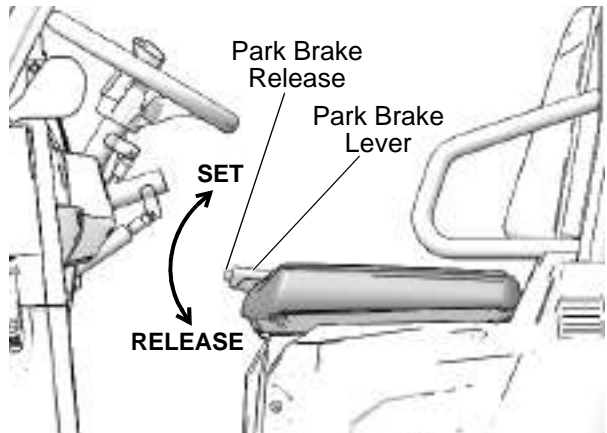

FEATURES AND CONTROLS

Mirrors

Use the mirrors to assist in traffic maneuvers. Always check and adjust the mirrors before driving the vehicle.

Seat Removal

Pull up on the front of the seat and slide it toward the front of the vehicle. Install the seat by sliding the tabs into the rear of the seat base. Push down firmly on the front of the seat until the pins are fully seated into the grommets.

Electronic Power Steering (EPS)

Electronic power steering (if equipped) engages when the ignition key is turned to the ON position. EPS remains engaged whether the vehicle is moving or idle.

To conserve battery power, the EPS will shut down 5 minutes after the engine is stopped if the key remains in the ON position. The EPS warning indicator will illuminate to indicate the EPS has shut down. Turn the key off and on to reset the unit.

See page 32 for EPS warning indicator information.

Fuel Cap

The fuel tank filler cap is located on the right-hand side of the vehicle near the passenger seat. When refueling, always use either leaded or unleaded gasoline with a minimum pump octane number of 87 R+M/2 octane. *Do not use fuel with ethanol content greater than 10 percent, such as E-85 fuel.*

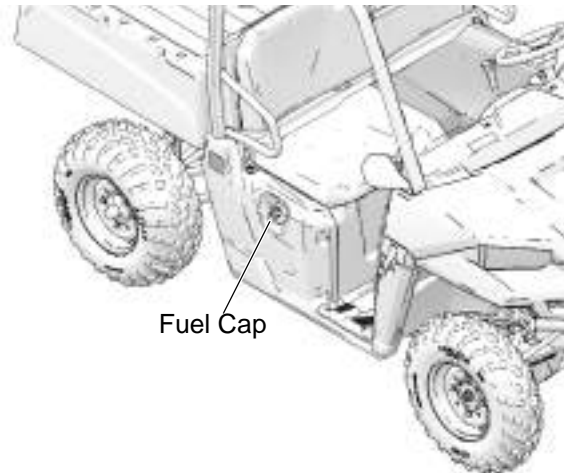

FEATURES AND CONTROLS

Steering Lock (if equipped)

Lock the steering to prevent unauthorized use or theft of the vehicle.

WARNING! Always unlock the steering before starting the engine.

NOTICE: Always remove the steering lock key before operating the vehicle. Place the steering lock keys in a safe place. The lock must be replaced if the keys are lost.

1. Turn the steering wheel full right or full left.
2. Open the steering lock cap. Insert the steering lock key and turn it clockwise.
3. Continue applying light clockwise pressure to the key while moving the steering wheel *slowly* in the reverse direction. When you feel a click and slight movement of the key, the steering has locked. Attempt to move the steering wheel to verify that it's locked.
4. Remove the key. Reinstall the steering lock cap.
5. To unlock the steering, insert the steering lock key and turn it counter-clockwise. Remove the key.



Steering
Lock Cap

Steering
Lock Key

Extreme Use 30 AH Battery (Non-EPS Models Only)

If your factory-installed battery cannot maintain a charge because of operation in extreme cold or with multiple electrical accessories, please see your POLARIS dealer to purchase a 30 AH battery. To install this battery to your vehicle, you will also need to purchase the 30 AH battery strap bracket. See page 92 for the part numbers of POLARIS products.

1. Fully charge the new battery before installing it. See page 85.
2. To install the 30 AH battery, remove the existing battery. See page 83.
3. Remove the plastic spacer at the bottom of the battery compartment. Save the spacer for future use.
4. Install the new battery. See page 84.

Seat Belts

This POLARIS vehicle is equipped with three-point lap and diagonal seat belts for the operator and passenger. Always make sure the seat belts are secured for all riders before operating. The driver's seat belt is equipped with a seat belt interlock. Vehicle speed will be limited to 24 km/h (15 MPH) if the seat belt is not secured.

The center of the seat is NOT equipped with a seat belt. Never allow a passenger to ride between the operator and passenger seats.

WARNING! Falling from a moving vehicle could result in serious injury or death. Always fasten your seat belt securely before operating or riding in the *RANGER*.

To wear the seat belt properly, follow this procedure:

1. For 3-point belts, pull the seat belt latch downward and across your chest toward the buckle at the inner edge of the seat. The belt should fit snugly across your hips and diagonally across your chest. Make sure the belt is not twisted.
2. Push the latch plate into the buckle until it clicks.
3. Release the strap, it will self tighten.
4. To release the seat belt, press the square red button in the buckle's center.

Seat Belt Inspection

Inspect all seat belts for proper operation before each use of the vehicle.

1. Push the latch plate into the buckle until it clicks. The latch plate must slide smoothly into the buckle. A click indicates that it's securely latched.
2. Push the red release latch in the middle of the buckle to make sure it releases freely.
3. Pull each seat belt completely out and inspect the full length for any damage, including cuts, wear, fraying or stiffness. If any damage is found, or if the seat belt does not operate properly, have the seat belt system checked and/or replaced by an authorized POLARIS dealer.
4. To clean dirt or debris from the seat belts, sponge the straps with mild soap and water. Do not use bleach, dye or household detergents. Rinse the entire length of the belt webbing. Use a garden hose to flush out the retractor and latch housings regularly.

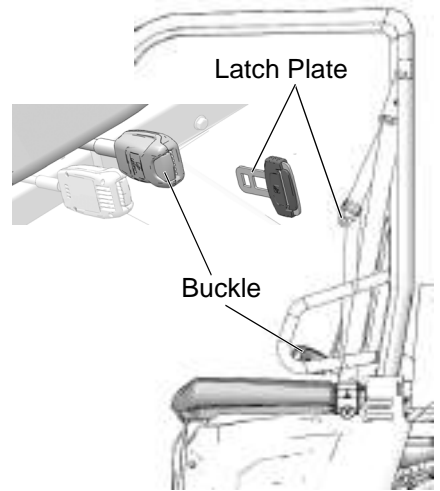

FEATURES AND CONTROLS

Cab Nets

Riding in this vehicle without using the cab nets (or doors, if equipped) increases the risk of serious injury or death in the event of an accident or rollover. Cab nets (or doors) must be used by both operator and passengers at all times. Make sure all latches are secure before operating the vehicle.

Always inspect cab nets and latches for tightness, wear and damage before each use of the vehicle. Use the strap adjusters to tighten any loose straps. Promptly replace worn or damaged cab nets and latches with new cab nets and latches. Please see your authorized POLARIS dealer.

Securing a Net

1. After entering the vehicle, insert the lower net rod into the net mount on the floor. Make sure the ball at the end of the rod is properly secured in the slot at the base of the mount.
2. Connect the latch at the top edge of the net to the receiver latch mounted on the front frame.

Opening a Net

1. To exit the vehicle, release the top front latch.
2. Rotate the net rearward and slide the lower net rod out of the mount to remove it.
3. Allow the net to hang freely outside the vehicle while dismounting.

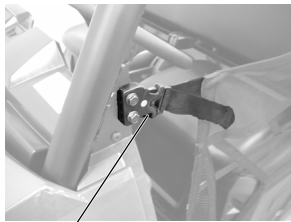

Top Latch

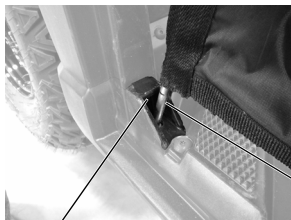

Rod Mount

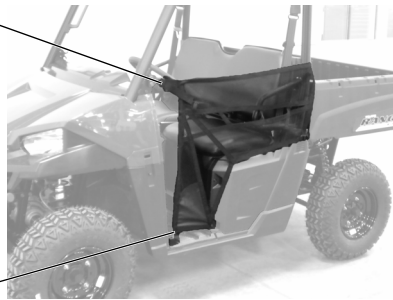

Net Rod

FEATURES AND CONTROLS

Rollover Protective Structure (ROPS)

The Rollover Protective Structure (ROPS) on this vehicle meets OSHA 1928.53 rollover performance requirements. Always have your authorized POLARIS dealer thoroughly inspect the ROPS if it ever becomes damaged in any way.

No device can assure occupant protection in the event of a rollover. Always follow all safe operating practices outlined in this manual to avoid vehicle rollover.

WARNING! Vehicle rollover could cause severe injury or death. Always avoid operating in a manner that could result in vehicle rollover.

Trailer Hitch Bracket

This vehicle is equipped with a receiver hitch bracket for a trailer hitch. Trailer towing equipment is not supplied with this vehicle.

To avoid injury and property damage, always heed the warnings and towing capacities outlined on pages 46-47.

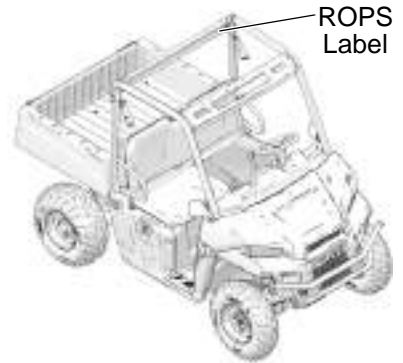

FEATURES AND CONTROLS

Instrument Cluster

High water pressure may damage components. Wash the vehicle by hand or with a garden hose using mild soap. Do not use alcohol to clean the instrument cluster. Do not allow insect sprays to contact the lens.

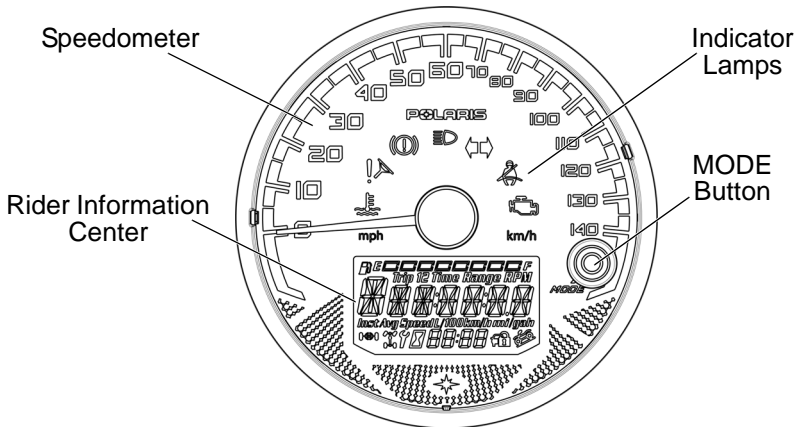

Speedometer

The speedometer displays vehicle speed in either miles per hour (MPH) or kilometers per hour (km/h). See page 34.

Indicator Lamps

Lamp	Indicates	Condition
	Vehicle Speed	When standard mode is selected, speed displays in miles per hour.
		When metric mode is selected, speed displays in kilometers per hour.
	Over Temperature	This lamp illuminates to indicate an overheated engine. If the indicator flashes, the overheating condition remains, and the system will automatically reduce engine power.
	EPS Warning	This indicator illuminates briefly when the key is turned to the ON position. If the light remains on, the EPS system is inoperative. Your authorized POLARIS dealer can assist.
	Brake Failure	This lamp illuminates when low pressure is detected in the hydraulic brake system (if equipped).
	High Beam	This lamp illuminates when the headlamp switch is set to high beam.
	Helmet/Seat Belt	This lamp is a reminder to the operator to ensure all riders are wearing helmets and seat belts before operating. The driver's seat belt is equipped with a seat belt interlock. Vehicle speed will be limited to 24 km/h (15 MPH) if the seat belt is not secured.
	Check Engine	This indicator appears if an EFI-related fault occurs. Do not operate the vehicle if this warning appears. Serious engine damage could result. See your dealer.
	Direction Indicators	A direction indicator flashes when a turn signal is active. Both indicators flash when the hazard signal is active.

FEATURES AND CONTROLS

Instrument Cluster

Rider Information Center

The rider information center is located in the instrument cluster. All segments will light up for one second at start-up. If the instrument cluster fails to illuminate, a battery over-voltage may have occurred and the instrument cluster may have shut off to protect the electronic speedometer. If this occurs, take the vehicle to your POLARIS dealer for proper diagnosis.

The information center is set to display standard units of measurement and a 12-hour clock at the factory. To change to metric and/or a 24-hour clock, see page 34.

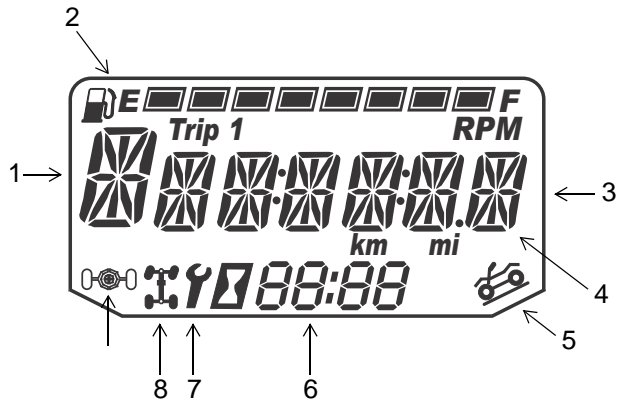

1. **Gear Indicator** - This indicator displays gear shifter position.
H = High Gear
L = Low Gear
N = Neutral
R = Reverse Gear
P = Park
-- = Gear Signal Error (or shifter between gears)
2. **Fuel Gauge** - The segments of the fuel gauge show the level of fuel in the fuel tank. When the last segment clears, a low fuel warning is activated. All segments including the fuel icon will flash. Refuel immediately.
Tip: If the fuel icon fails to display, an open or short circuit has occurred in the fuel sensor circuit. See your dealer.
3. **Information Display Area** - This area displays odometer, trip meter, engine hour meter and programmable service hour interval.
4. **Under / Over Voltage** - This warning usually indicates that the vehicle is operating at an RPM too low to keep the battery charged. It may also occur when the engine is at idle and high electrical load (lights, cooling fan, accessories) is applied. Drive at a higher RPM or recharge the battery to clear the warning.
5. **Active Descent Control (ADC) Indicator (if equipped)** - This indicator illuminates when ADC mode is selected.
6. **Clock** - The clock displays time in a 12-hour or 24-hour format. See page 34 for resetting instructions.
7. **Service Indicator** - A flashing wrench symbol alerts the operator that the preset service interval has been reached. The vehicle should be brought to your dealer for scheduled maintenance. See page 34 for resetting instructions.
8. **4X4 Indicator (if equipped)** - This indicator illuminates when the 4X4 system is engaged.

FEATURES AND CONTROLS

Instrument Cluster

Rider Information Center

Use the MODE button to toggle through the information area options.

Display Units (Standard/Metric)

The display can be changed to display either standard or metric units of measurement.

Tip: To exit the set-up mode at any time, wait 10 seconds. The display automatically exits and returns to the odometer display.

	Standard Display	Metric Display
Distance	Miles	Kilometers
Fuel	U.S. Gallons	Liters, Imperial Gallons
Temperature	Fahrenheit	Celsius
Time	12-Hour Clock	24-Hour Clock

1. Turn the key to the OFF position.
2. Press and *hold* the MODE button while turning the key to the ON position.
3. When the display flashes the distance setting, tap the MODE button to advance to the desired setting.
4. Press and *hold* the MODE button to save the setting and advance to the next display option.
5. Repeat the procedure to change remaining display settings.

Clock Mode

Tip: The clock must be reset any time the battery has been disconnected or discharged.

1. Turn the key to the ON position. Use the MODE button to toggle to the odometer display.
2. Press and *hold* the MODE button until the hour segment flashes. Release the button.
3. With the segment flashing, tap the MODE button to advance to the desired setting.
4. Press and *hold* the MODE button until the next segment flashes. Release the button.
5. Repeat steps 3-4 twice to set the 10-minute and 1-minute segments. After completing the 1-minute segment, step 4 will save the new settings and exit the clock mode.
6. Turn the key to the OFF position.

Instrument Cluster Rider Information Center Odometer Mode

The odometer records and displays the distance traveled by the vehicle.

Trip Meter Mode

The trip meter records the distance traveled by the vehicle if reset before each trip. To reset, select the trip meter mode. Press and hold the MODE button until the meter resets to zero. In the Rider Information Center, the trip meter display contains a decimal point, but the odometer displays without a decimal point.

Hour Meter Mode

This mode logs the total hours the engine has been in operation.

Tachometer Mode

The engine RPM is displayed digitally.

Tip: Small fluctuations in the RPM from day to day may be normal because of changes in humidity, temperature and elevation.

Programmable Service Interval

When the hours of engine operation equal the programmed service interval setting, the wrench icon will flash for 5 seconds each time the engine is started. When this feature is enabled, it provides a convenient reminder to perform routine maintenance. The service interval is programmed at 50 hours at the factory. Use the following procedure to change the service interval.

1. Press the MODE button until remaining service hours display.
2. Press and hold the MODE button.
3. When the service hours flash, press and release the MODE button to advance the hours to the desired setting (including OFF). Press and hold the MODE button to set the new service hour interval.

Diagnostic Display Mode

The EFI diagnostic display mode is for informational purposes only. Please see your POLARIS dealer for all major repairs.

The diagnostic mode is accessible only when the check engine warning indicator activates after the key has been turned on. Leave the key on if you want to view the active code (failure code).

The diagnostic mode becomes inaccessible if the key is turned off and on and the warning indicator is no longer active. This allows the determination of persistent as well as intermittent faults.

Inactive codes are stored in the history of the unit.

FEATURES AND CONTROLS

Instrument Cluster

Rider Information Center

Engine Error Codes

The error screen displays only when the CHECK ENGINE light is on or when it goes on and off during one ignition cycle. Error codes are not stored. When the key is turned OFF, the code and message is lost, but will reappear if the fault reoccurs after restarting the engine.

If the CHECK ENGINE light illuminates, retrieve the error codes from the display.

1. If the error codes are not displayed, use the MODE button to toggle until "Ck ENG" displays on the main line of the display.
2. Press and hold the MODE button to enter the diagnostics code menu.
3. Record the three numbers displayed in the gear position, clock and odometer displays.
4. Press the MODE button to advance to the next error code.
5. Press and hold the MODE button to exit the diagnostics code menu.
6. See an authorized POLARIS dealer for code details and diagnosis.

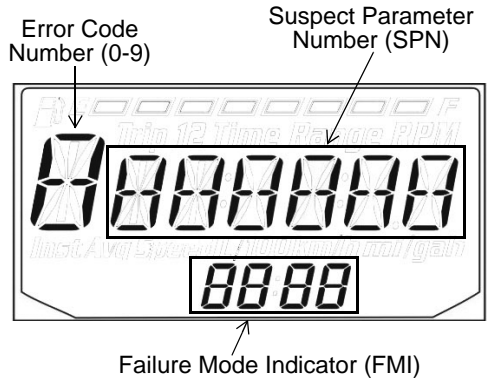

⚠ WARNING

Failure to operate the vehicle properly can result in a collision, loss of control, accident or rollover, which may result in serious injury or death. Read and understand all safety warnings outlined in the safety section of this owner's manual.

Break-In Period

The break-in period for your new POLARIS *RANGER* is the first twenty hours of operation, or the time it takes to use the first two tanks full of gasoline. No single action on your part is as important as a proper break-in period. Careful treatment of a new engine will result in more efficient performance and longer life for the engine. Perform the following procedures carefully.

NOTICE: Excessive heat build-up during the first three hours of operation will damage close-fitted engine parts. Do not operate at full throttle or high speeds for extended periods during the first three hours of use.

Engine and Drivetrain Break-in

1. Fill the fuel tank with gasoline. Heed the gasoline warnings on page 20.
2. Check the oil level. See page 64. Add the recommended oil as needed to maintain the oil level in the normal (safe) operating range.
3. Drive slowly at first. Select an open area that allows room to familiarize yourself with vehicle operation and handling.
4. Vary throttle positions. Do not operate at sustained idle.
5. Perform regular checks on fluid levels, controls and areas outlined on the daily pre-ride inspection checklist. See page 38.
6. Pull only light loads.
7. Check fluid levels of transmission and all gearcases after the first 25 hours of operation and every 100 hours thereafter.
8. During the break-in period, change both the oil and the filter at 25 hours.

PVT Break-in (Clutches/Belt)

A proper break-in of the clutches and drive belt will ensure a longer life and better performance. Break in the clutches and belt by operating at slower speeds during the break-in period as recommended. Pull only light loads. Avoid aggressive acceleration and high speed operation during the break-in period.

If a belt fails, always clean any debris from the clutch air duct and from the clutch and engine compartments when replacing the belt. See page 71.

OPERATION

Pre-Ride Inspection

Failure to inspect and verify that the vehicle is in safe operating condition before operating increases the risk of an accident. Always inspect the vehicle before each use to make sure it's in safe operating condition.

Item	Remarks	Page
Brake system/pedal travel	Ensure proper operation	26, 76
Brake fluid	Ensure proper level	76
Park gear	Ensure vehicle does not roll when in PARK. Ensure PARK light illuminates.	-
Front suspension	Inspect, lubricate if necessary	63
Rear suspension	Inspect, lubricate if necessary	63
Steering/steering lock	Unlock the steering; ensure free operation	77
Tires	Inspect condition and pressure	78
Wheels/fasteners	Inspect, ensure fastener tightness	78
Frame nuts, bolts, fasteners	Inspect, ensure tightness	-
Fuel and oil	Ensure proper levels	27, 64
Coolant level	Ensure proper level	70
Coolant hoses	Inspect for leaks	-
Throttle	Ensure proper operation	26
Indicator lights/switches	Ensure operation	-
Air filter, pre-filter	Inspect, clean	74
Headlamp	Check operation, apply POLARIS dielectric grease when lamp is replaced	80
Brake light/tail lamp	Check operation, apply POLARIS dielectric grease when lamp is replaced	81
Turn Signals	Ensure operation of all signal lamps	25
Mirrors	Adjust for best side/rear vision	27
Horn	Ensure operation	24
Seat Belts	Check length of belt for damage, check latches for proper operation	29
Cab Nets	Check for wear or damage, ensure proper installation	30
Riding gear	Wear approved helmet, goggles and protective clothing	8

Starting Engine

1. Always start the engine outdoors or in a well-ventilated area.
2. Sit in the driver's seat and fasten the seat belt. Secure the cab nets (or doors).
3. Apply the brakes. Place the transmission in **PARK**.
4. Do not press the throttle pedal while starting the engine.
5. Turn the ignition key to the **START** position. Engage the starter for a maximum of five seconds. Release the key when the engine starts. Turn the key to either **LIGHTS ON** or **POSITION LIGHTS ON**.
6. If the engine does not start within five seconds, release the ignition switch and wait five seconds. Repeat steps 5-6 until the engine starts.

NOTICE: Operating the vehicle immediately after starting could cause engine damage. Allow the engine to warm up for several minutes before operating the vehicle.

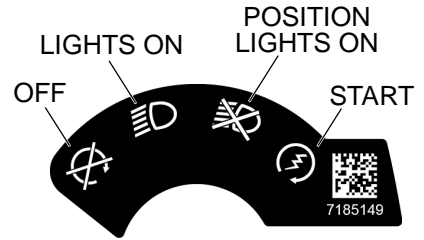

MD Models

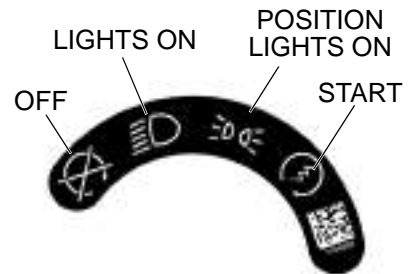

EU Models

Stopping the Engine

1. Release the throttle pedal completely and brake to a complete stop.
2. Turn the engine off.
3. Place the transmission in **PARK**.
4. Slowly release the brake pedal and make sure the transmission is in **PARK** before exiting the vehicle.
5. Engage the park brake.

WARNING! A rolling vehicle can cause serious injury. Always place the transmission in **PARK** and engage the park brake when stopping the engine.

Braking

1. Release the throttle pedal completely.
2. Press on the brake pedal evenly and firmly.
3. Practice starting and stopping (using the brakes) until you're familiar with the controls.

Tip: When the throttle pedal is released completely and the engine speed drops near an idle, the vehicle has no engine braking.

OPERATION

Driving Procedure

1. Wear a helmet, eye protection, gloves, long-sleeve shirt, long pants and over-the-ankle boots.
2. Sit in the driver's seat and fasten the seat belt.
3. Start the engine and allow it to warm up.
4. Always use the cab nets (or doors) while riding in this vehicle.
5. Apply the service brakes and shift the transmission into gear.
6. Check your surroundings and determine your path of travel.
7. Release the park brake.
8. Keeping both hands on the steering wheel, slowly release the brakes and depress the throttle with your right foot to begin driving.
9. Drive slowly. Practice maneuvering and using the throttle and brakes on level surfaces.
10. Do not carry a passenger until you have at least two hours of driving experience with this vehicle.

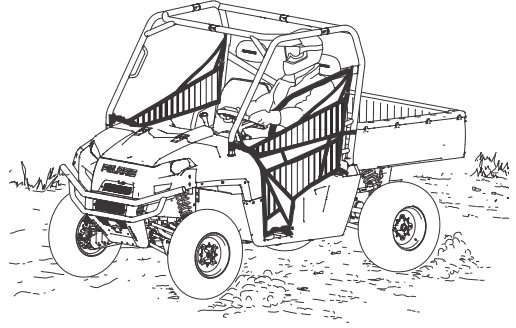

Driving with a Passenger

1. Perform the pre-ride inspection. See page 38.
2. Make sure all passengers are at least 12 years of age and tall enough to comfortably and safely sit in a passenger seat with the seat belt secured, put both feet on the floor and grasp the hand hold.
3. Make sure all passengers are wearing helmet, eye protection, gloves, long-sleeve shirt, long pants and over-the-ankle boots.
4. Make sure all passengers secure their seat belt.
5. Make sure all cab nets (or doors) are properly secured.
6. Do not carry more than the recommended number of passengers for your vehicle. See page 90.
7. Allow a passenger to ride only in a passenger seat.
8. Slow down. Always travel at a speed appropriate for your skills, your passengers' skills, and operating conditions. Avoid unexpected or aggressive maneuvers that could cause discomfort or injury to a passenger.
9. Vehicle handling may change with a passenger and/or cargo on board. Allow more time and distance for braking.
10. Always follow all operating guidelines as outlined on safety labels and in this manual.

Driving On Slippery Surfaces

⚠ WARNING

Skidding or sliding can cause loss of control or rollover (if tires regain traction unexpectedly). When operating on slippery surfaces such as ice or loose gravel, reduce speed and use extra caution to reduce the chance of skidding or sliding out of control. Do not operate on excessively slippery surfaces.

Whenever riding on slippery surfaces such as wet trails or loose gravel, or during freezing weather, follow these precautions:

1. Do not operate on excessively rough, slippery or loose terrain.
2. Slow down before entering slippery areas.
3. Maintain a high level of alertness, reading the trail and avoiding quick, sharp turns, which can cause skids.
4. Engage all-wheel drive before wheels begin to lose traction.

NOTICE: Severe damage to the drive train may occur if the AWD is engaged while the wheels are spinning. Always allow the wheels to stop spinning before engaging AWD.

5. Correct a skid by turning the steering wheel in the direction of the skid. *Never apply the brakes during a skid.*

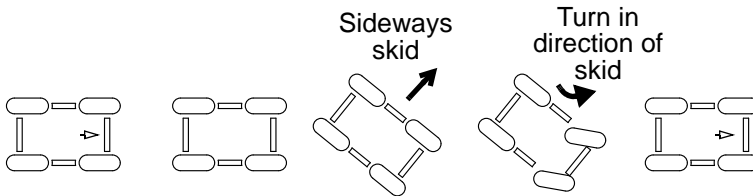

Driving Over Obstacles

Follow these precautions when operating over obstacles:

1. Always check for obstacles before operating in a new area.
2. Look ahead and learn to read the terrain. Be constantly alert for hazards such as logs, rocks and low hanging branches.
3. Travel slowly and use extra caution when operating on unfamiliar terrain. Not all obstacles are immediately visible.
4. Avoid operating over large obstacles such as large rocks and fallen trees. If unavoidable, use extreme caution and operate slowly.
5. Always have all passengers dismount and move away from the vehicle before operating over an obstacle that could cause a rollover.

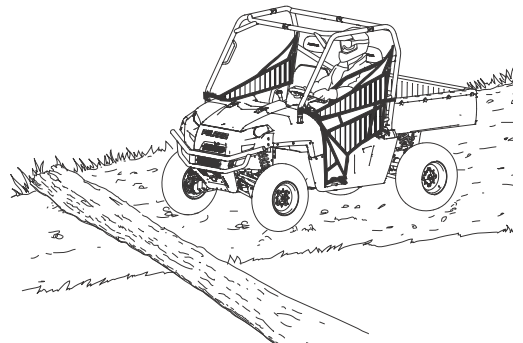

OPERATION

Driving Uphill

Whenever traveling uphill, follow these precautions:

1. Always travel straight uphill.
2. **ADC Models:** Always operate in low gear and engage ADC 4X4 before ascending or descending a hill.
3. Avoid excessively steep hills.
4. Keep both feet on the floor.
5. Always check the terrain carefully before ascending any hill. Never climb hills with excessively slippery or loose surfaces.
6. Proceed at a steady rate of speed and throttle opening. Never open the throttle suddenly.
7. Never go over the crest of a hill at high speed. An obstacle, a sharp drop, or another vehicle or person could be on the other side of the hill.

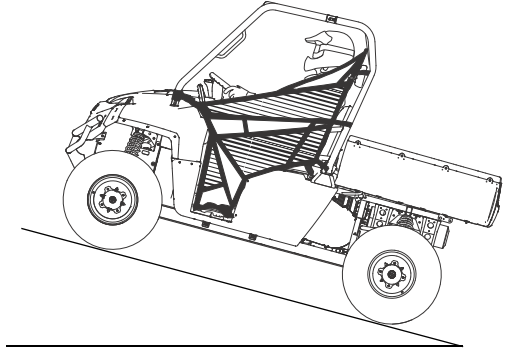

Driving Downhill

When driving downhill, follow these precautions:

1. Avoid excessively steep hills.
2. **ADC Models:** Always operate in low gear and engage ADC 4X4 before ascending or descending a hill.
3. Drive straight downhill. Avoid descending a hill at an angle, which would cause the vehicle to lean sharply to one side. Travel straight downhill when possible.
4. Slow down.
5. Apply the brakes *slightly* to aid in slowing.

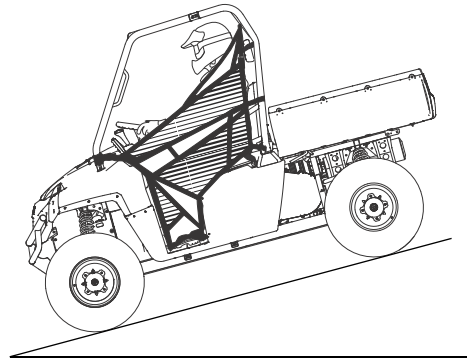

Driving on a Sidehill (Sidehilling)

Driving on a sidehill is not recommended. Improper procedure could cause loss of control or rollover. Avoid crossing the side of any hill unless absolutely necessary.

If crossing a sidehill is *unavoidable*, follow these precautions:

1. Slow down.
2. Exercise extreme caution.
3. Avoid crossing the side of a steep hill.
4. **ADC Models:** Always operate in low gear and engage ADC 4X4 before ascending or descending a hill.

Driving in Reverse

Follow these precautions when operating in reverse:

1. Always check for obstacles or people behind the vehicle. Always inspect left and right fields of vision before backing.
2. Always avoid backing downhill.
3. Back slowly.
4. Apply the brakes *lightly* for stopping.
5. Avoid turning at sharp angles.
6. Never open the throttle suddenly.

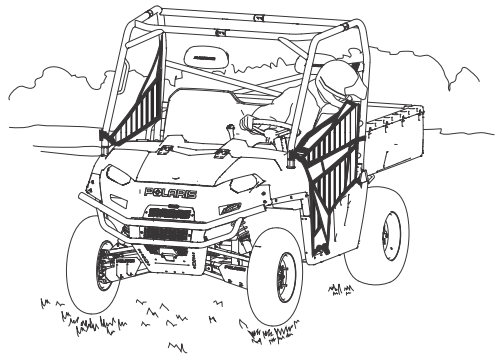

OPERATION

Driving Through Water

Your POLARIS *RANGER* can operate through water up to a maximum recommended depth equal to the floorboards.

NOTICE: Immersion can result in major damage if the vehicle isn't serviced correctly and promptly. After immersion, always take the vehicle to your dealer service. Do not start the engine! If it's impossible to bring the vehicle to your dealer before starting the engine, perform the service outlined on page 73, and take the vehicle to your dealer at the first opportunity.

Follow these procedures when operating through water:

1. Determine water depths and current before entering water.
2. Choose a crossing where both banks have gradual inclines.
3. Proceed slowly, avoiding rocks and obstacles.
4. Avoid operating through deep or fast-flowing water.

WARNING! The large tires on your *RANGER* may cause the vehicle to float in deep or fast-flowing water, which could result in loss of control and lead to serious injury or death. Never cross deep or fast-flowing water with your *RANGER*.

5. After leaving water, always dry the brakes by applying light pressure to the pedal repeatedly until braking action is normal.

NOTICE: After running your vehicle in water, it's critical that you perform the services outlined in the Periodic Maintenance Chart beginning on page 61. Give special attention to engine oil, transmission oil, front and rear gearcases (if equipped), and all grease fittings.

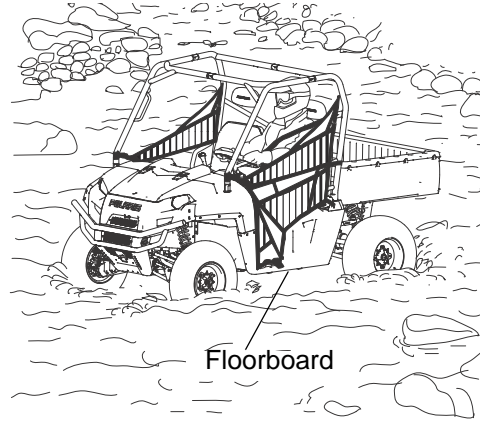

Parking the Vehicle

1. Apply the brakes. Stop the vehicle on a level surface.
2. When parking inside a garage or other structure, be sure that the structure is well ventilated and that the vehicle is not close to any source of flame or sparks, including any appliance with pilot lights.
3. Place the transmission in PARK.
4. Engage the park brake.
5. Turn the engine off.
6. Slowly release the brake pedal and make sure the transmission is in PARK before exiting the vehicle.
7. Remove the ignition switch key to prevent unauthorized use.

Parking on an Incline

Avoid parking on an incline if possible. If it's unavoidable, follow these precautions:

1. Apply the brakes.
2. Place the transmission in PARK.
3. Engage the park brake.
4. Turn the engine off.
5. Slowly release the brake pedal and make sure the transmission is in PARK before exiting the vehicle.
6. Block the rear wheels on the downhill side.

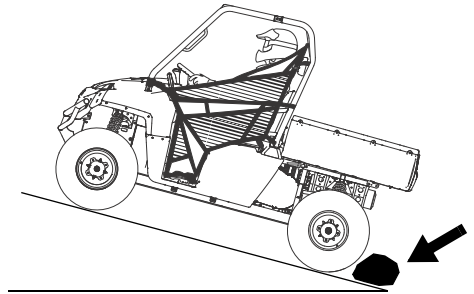

OPERATION

Hauling Cargo

⚠ WARNING

Hauling cargo improperly can alter vehicle handling and may cause loss of control or brake instability, which can result in serious injury or death. Always follow these precautions when hauling cargo:

Never exceed the maximum weight capacity of the vehicle. When determining the weight you are adding to the vehicle, include the weight of the operator, passenger, accessories, loads in the rack or box and the load on the trailer tongue. The combined weight of these items must not exceed the maximum weight capacity.

REDUCE SPEED AND ALLOW GREATER DISTANCES FOR BRAKING WHEN HAULING CARGO.

Always load the cargo box with the load as far forward and as low as possible.

When operating over rough or hilly terrain, reduce speed and cargo to maintain stable driving conditions.

Always operate the vehicle with extreme care when hauling or towing loads.

Slow down and drive in the lowest gear available.

SECURE ALL LOADS BEFORE OPERATING. Unsecured loads can create unstable operating conditions, which could result in loss of control of the vehicle.

OPERATE ONLY WITH STABLE AND SAFELY ARRANGED LOADS. When handling off-centered loads that cannot be centered, securely fasten the load and operate with extra caution. Always attach the tow load to the hitch point designated for your vehicle.

HEAVY LOADS CAN CAUSE BRAKING AND CONTROL PROBLEMS. Use extreme caution when applying brakes with a loaded vehicle. Avoid terrain or situations that may require backing downhill.

USE EXTREME CAUTION when operating with loads that extend over the rack sides. Stability and maneuverability may be adversely affected, causing a rollover.

DO NOT TRAVEL FASTER THAN THE RECOMMENDED SPEEDS. Vehicle should never exceed 16 km/h (10 MPH) while towing a load on a level grass surface. Vehicle speed should never exceed 8 km/h (5 MPH) when towing loads in rough terrain, while cornering, or while ascending or descending a hill.

The *RANGER* has been designed to carry or tow specific capacities. Always read and understand the load distribution warnings listed on the warning labels. The total load (operator, passenger, accessories, cargo and weight on hitch) must not exceed the maximum weight capacity of the vehicle. Never exceed the following capacities.

Model	Maximum Capacities (Level Ground)	Cargo Box
<i>RANGER 570</i>	454 kg (1000 lbs.)	227 kg (500 lbs.)

WARNING! Driving with passengers in the cargo box can result in severe injury or death. Never allow passengers to ride in the cargo box. Passengers must always ride in the cab with seat belts fastened securely.

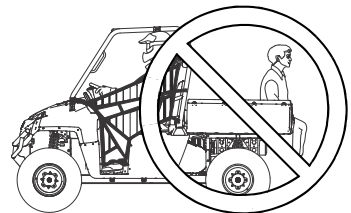

Towing Loads

Towing improperly can alter vehicle handling and may cause loss of control or brake instability. Always follow these precautions when towing:

1. Never load more than 68.1 kg (150 lbs.) tongue weight on the towing bracket.
2. Always operate in low gear and engage ADC 4X4 (if equipped) when transporting heavy loads and/or when towing.
3. When towing a disabled *RANGER* vehicle, place the disabled vehicle's transmission in neutral. Do not operate the vehicle faster than 16 km/h (10 MPH) when towing.
4. Do not operate the vehicle faster than 16 km/h (10 MPH) when towing. See page 46. Towing a trailer increases braking distance.
5. Do not tow more than the recommended weight for the vehicle. See the towing capacity chart below and the specifications charts beginning on page 90.
6. Attach a trailer to the trailer hitch bracket only. Do not attach a trailer to any other location or you may lose control of the vehicle.
7. Never tow a trailer on a grade steeper than 15°.

Model	Total Towed Load Weight (Level Ground)	Total Towed Load Weight (15° grade)	Total Hitch Vertical Weight	Maximum Towing Speed
<i>RANGER 570</i>	680.4 kg (1500 lbs.)	386 kg (850 lbs.)	68.1 kg (150 lbs.)	16 km/h (10 MPH)

Belt Life

To extend belt life, use the lowest gear possible when hauling or towing heavy cargo.

Towing a RANGER

Towing this vehicle is not recommended. Always transport the vehicle on a trailer or flatbed with all four wheels off the ground. See page 89.

If towing a disabled vehicle is unavoidable, place the disabled vehicle's transmission in neutral. Tow the shortest distance possible. Do not operate faster than 10 MPH (16 km/h).

OPERATION

Dumping the Cargo Box

1. Select a level site to dump the cargo box. Do not attempt to dump or unload the vehicle while parked on an incline.
2. Apply the brakes.
3. Place the transmission in PARK.
4. Engage the park brake.
5. Dismount the vehicle.
6. Ensure that the cargo is positioned evenly or toward the front of the cargo box.
7. Release the tailgate latches.

WARNING! If the weight distribution on the box is located toward the rear of the box when the release lever is pulled forward, the box may dump unexpectedly and cause serious injury to the operator or bystanders. Never operate the dump lever without ensuring that the load is positioned evenly or at the front of the box.

8. Stand clear and pull up on the cargo box release lever. Lift the front of the cargo box to dump the cargo.
9. Lower the cargo box and push down securely to latch.
10. Close the tailgate and secure both tailgate latches.

WARNING! Operating the vehicle while the cargo box is raised could result in severe injury. The box could close unexpectedly and cause injury to the driver or passenger. The rear tires will also catch the rear of a raised box, damaging the vehicle and creating hazardous driving conditions. Never operate this vehicle with the cargo box in the raised position.



All Wheel Drive (AWD) (4X4 Models)

This vehicle is equipped with a drive mode switch that controls the AWD system. The AWD Drive Mode switch controls AWD through drive mode options.

Drive Mode Switch

MD Models:

Press and release the top of the switch to enable AWD Mode. Press and release the bottom of the switch to enable 2x4 Mode.

EU Models:

Press and release the top of the switch to toggle through the drive mode options. The selected drive mode displays in the instrument cluster.

Press and release the bottom of the switch to toggle to a previous option.

When the switch is released, the drive mode displayed is the active drive mode.

NOTICE: Switching to 4X4 or ADC 4X4 (if equipped) while the rear wheels are spinning may cause severe drive shaft and gearcase damage. Always switch to 4X4 or ADC 4X4 while the rear wheels have traction or are at rest.



MD Models

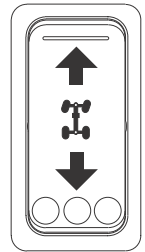

EU Models

Drive Mode Operation

Drive mode options include:

- ADC - All Wheel Drive (ADC 4X4) (if equipped)
- AWD - All Wheel Drive (AWD/4X4)
- 2WD - Two Wheel Drive (2X4)
- TURF - TURF Mode (1WD)

WARNING! Operate in TURF mode only as needed to protect smooth, level surfaces from tire damage. DO NOT operate in TURF mode when climbing or descending hills, when sidehilling, or when operating on uneven, loose, or slippery terrain such as sand, gravel, ice, snow, obstacles, and water crossings.

The vehicle automatically engages 4X4 when operating in reverse if the drive mode is set to either AWD (4X4) or ADC 4X4.

If your vehicle is equipped with Active Descent Control (ADC):

- Always operate in low gear and engage ADC 4X4 when transporting heavy loads and/or when towing.
- Always operate in low gear and engage ADC 4X4 before ascending or descending a hill.

See page 51 for Active Descent Control (ADC) System information.



OPERATION

All Wheel Drive (AWD) (4X4 Models)

Engaging AWD

When AWD is selected, the front gearcase will automatically engage any time the rear wheels lose traction. When the rear wheels regain traction, the front gearcase will automatically disengage. There is no limit to the length of time the vehicle may remain in AWD.

Initially, the vehicle's electronic system will not enable the AWD until the engine RPM is below 3100. Once enabled, the AWD remains enabled until the AWD is disabled (set to 2X4 or TURF). If AWD is turned off while the front gearcase is moving, it will not disengage until the rear wheels regain traction.

Engage the AWD before getting into conditions where front wheel drive may be needed. If the rear wheels are spinning, release the throttle before switching to AWD.

NOTICE: Switching to AWD while the rear wheels are spinning may cause severe drive shaft and clutch damage. Always switch to AWD while the rear wheels have traction or are at rest.

Disengaging AWD

Toggle the AWD Drive Mode Switch to 2X4 or TURF to disengage AWD. If AWD is disengaged while the front hubs are driving, the hubs will not release until the rear wheels regain traction.

In some situations, the front gearcase may remain locked after disengaging AWD. If this occurs, you may notice increased steering effort and some vehicle speed restriction. Perform the following procedure to unlock the front gearcase.

1. Stop the vehicle.
2. Operate in reverse for at least 3 m (10 feet).
3. Stop completely.
4. Shift into low gear and drive forward.
5. If the front gearcase remains locked after following these instructions, see your dealer for service.

All Wheel Drive (AWD) (4X4 Models)

Active Descent Control (ADC) System (if equipped)

The ADC system allows engine braking to all four wheels when the vehicle descends a hill or incline.

- *Always operate in low gear and engage ADC 4X4 when transporting heavy loads and/or when towing.*
- *Always operate in low gear and engage ADC 4X4 before ascending or descending a hill.*

Engaging Active Descent Control

The ADC system will automatically engage when *both* of the following conditions occur:

- The drive mode must be in the ADC 4X4 position
- The transmission must be in gear (high, low or reverse)

Disengaging Active Descent Control

The ADC system will automatically disengage if *at least one* of the following conditions occur:

- The drive mode is changed from the ADC 4X4 position
- The transmission is shifted to neutral or park

WINCH GUIDE

These safety warnings and instructions apply if your vehicle came equipped with a winch or if you choose to add an accessory winch to your vehicle.

⚠ WARNING

Improper winch use can result in SEVERE INJURY or DEATH. Always follow all winch instructions and warnings in this manual.

Your winch may have a cable made of either wire rope or specially designed synthetic rope. The term “winch cable” will be used for either unless noted otherwise.

Winch Safety Precautions

1. Read all sections of this manual.
2. Never use alcohol or drugs before or while operating the winch.
3. Never allow children under 16 years of age to operate the winch.
4. Always wear eye protection and heavy gloves when operating the winch.
5. Always keep body, hair, clothing and jewelry clear of the winch cable, fairlead and hook when operating winch.
6. Never attempt to “jerk” a load attached to the winch with a moving vehicle. See the *Shock Loading* section on page 58.
7. Always keep the area around the vehicle, winch, winch cable and load clear of people (especially children) and distractions while operating the winch.
8. Always turn the vehicle ignition power OFF when it and the winch are not being used.
9. Always be sure that at least five (5) full turns of winch cable are wrapped around the winch drum at all times. The friction provided by this wrapped cable allows the drum to pull on the winch cable and move the load.
10. Always apply your vehicle’s park brake and/or park mechanism to hold the vehicle in place during winching. Use wheel chocks if needed.
11. Always align the vehicle and winch with the load directly in front of the vehicle as much as possible. Avoid winching with the winch cable at an angle to the winching vehicle’s centerline whenever possible.
12. If winching at an angle is unavoidable, follow these precautions:
 - A. Look at the winch drum occasionally. Never let the winch cable “stack” or accumulate at one end of the winch drum. Too much winch cable at one end of the winch drum can damage the winch and the winch cable.
 - B. If stacking occurs, stop winching. Follow step 15 on page 57 to feed and rewind the cable evenly before continuing the winch operation.

Winch Safety Precautions

13. Never winch up or down at sharp angles. This can destabilize the winching vehicle and possibly cause it to move without warning.
14. Never attempt to winch loads that weigh more than the winch's rated capacity.
15. The winch motor may become hot during winch use. If you winch for more than 45 seconds, or if the winch stalls during operation, stop winching and permit the winch to cool down for 10 minutes before using it again.
16. Never touch, push, pull or straddle the winch cable while winching a load.
17. Never let the winch cable run through your hands, even if wearing heavy gloves.
18. Never release the clutch on the winch when the winch cable is under load.
19. Never use the winch for lifting or transporting people.
20. Never use the winch to hoist or suspend a vertical load.
21. Never immerse or submerge your winch in water. Take your winch to your dealer for service if this occurs.
22. Always inspect your winch and winch cable before each use.
23. Never winch the hook fully into the winch. This can cause damage to winch components.
24. Unplug the remote control from the vehicle when the winch is not in use to prevent inadvertent activation and use by unauthorized persons.
25. Never grease or oil the winch cable. This will cause the winch cable to collect debris that will shorten the life of the cable.

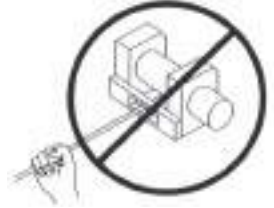

WINCH GUIDE

Winch Operation

Read the *Winch Safety Precautions* in the preceding pages before using your winch.

Tip: Consider practicing the operation and use of your winch before you actually need to use it in the field.

⚠ WARNING

Improper winch use can result in SEVERE INJURY or DEATH. Always follow all winch instructions and warnings in this manual.

Each winching situation is unique.

- Take your time to think through the winching you are about to do.
 - Proceed slowly and deliberately.
 - Never hurry or rush during winching.
 - Always pay attention to your surroundings.
 - You may need to change your winching strategy if it is not working.
 - Always remember that your winch is very powerful.
 - There are simply some situations that you and your winch will not be able to deal with. Do not be afraid to ask others to help when this happens.
1. Always inspect the vehicle, winch, winch cable and winch controls for any signs of damage or parts in need of repair or replacement before each use. *Pay particular attention to the first meter (3 feet) of winch cable if the winch is being used (or has been used) for lifting an accessory plow assembly.* Promptly replace any worn or damaged cable.
 2. Never operate a winch or a vehicle in need of repair or service.
 3. Always apply your vehicle's park brake and/or park mechanism to hold the vehicle in place during winching. Use wheel chocks if needed.

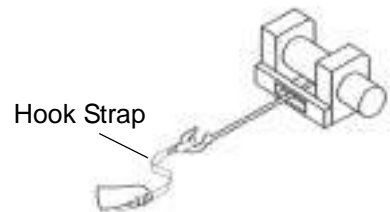

Winch Operation

4. Always use the hook strap when handling the hook.

WARNING! Never put your fingers into the hook. This could lead to SEVERE INJURY.

- A. Attach the hook itself onto the load or use a tow strap or chain to secure the load to the winch cable.

Tip: A “tow strap” is NOT intended to stretch. A “recovery strap” is designed to stretch.

WARNING! Never use a recovery strap when winching due to the excessive energy that can be released if the winch cable breaks. This can result in SEVERE INJURY or DEATH. See the *Shock Loading* section on page 58.

- B. Never hook the winch cable back onto itself. This will damage the winch cable and may result in winch cable failure.

WARNING! Replace the winch cable at the first sign of damage to prevent SEVERE INJURY or DEATH in the event of failure. For your safety, always replace POLARIS winch parts (including the cable) with genuine POLARIS replacement parts available at your authorized POLARIS dealer.

- C. If possible, keep the winch cable aligned with the centerline of the winching vehicle. This will help the spooling of the winch cable and reduce the load on the fairlead.
- D. If freeing a stuck vehicle by attaching to a tree, use an item such as a tow strap to avoid damaging the tree during winch operation. Sharp cables and chains can damage and even kill trees.
- E. Before operating the winch, be sure that the safety latch on the winch cable hook is fully seated when the load is attached.
- F. Never operate your winch with a damaged hook or latch. Always replace damaged parts before using the winch.

5. Never remove the hook strap from the hook.

6. Release the winch clutch and pull out the winch cable.

7. Pulling out as much cable as possible maximizes the winch’s pulling capacity. Always be sure that at least five (5) full turns of winch cable are wrapped around the winch drum at all times. The friction provided by this wrapped cable allows the drum to pull on the winch cable and move the load.



NO



YES

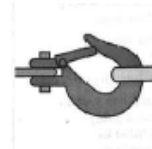

YES



NO

WINCH GUIDE

Winch Operation

8. Read and adhere to the following information for winch damping to ensure safe winch use.
 - A. In order to absorb energy that could be released by a winch cable failure, always place a “damper” on the winch cable. A damper can be a heavy jacket, tarp, or other soft, dense object. A damper can absorb much of the energy released if a winch cable breaks when winching. Even a tree limb can help as a damper if no other items are available to you.
 - B. Lay the damper on top of the mid-point of the winch cable length that is spooled out.
 - C. On a long pull, it may be necessary to stop winching so that the damper can be repositioned to the new mid-point of the winch cable. Always release the tension on the winch cable before repositioning the damper.
 - D. Avoid being directly in line with the winch cable whenever possible. Also, never permit others to stand near or in line with the winch cable during winch operation.
9. Never hook the winch cable back onto itself. This will damage the winch cable and may result in winch cable failure.
10. Never use straps, chains or other rigging items that are damaged or worn.
11. The **ONLY** time a winch-equipped vehicle should be moving when using the winch is when that vehicle itself is stuck. The winch-equipped vehicle should **NEVER** be in motion to “shock” load the winch cable in an attempt to move a second stuck vehicle. See the *Shock Loading* section on page 58. For your safety, always follow these guidelines when winching a vehicle free:
 - A. Release the winch clutch and spool out the necessary length of winch cable.
 - B. Align the winch cable as close as possible to the winching vehicle's centerline.
 - C. Attach the winch cable hook to the anchor point or the stuck vehicle's frame following instructions in this manual.
 - D. Re-engage the clutch on the winch.
 - E. Slowly winch in the slack in the winch cable.
 - F. Select the proper vehicle gear to propel the stuck vehicle in the direction of winching.
 - G. Shift to the lowest gear available on the stuck vehicle.
 - H. Slowly and carefully apply vehicle throttle and winch together to free the vehicle.
 - I. Stop winching as soon as the stuck vehicle is able to propel itself without the help of the winch.
 - J. Detach the winch cable hook.
 - K. Rewind the winch cable evenly back onto the winch drum following the instructions in this manual.
12. Never attempt to winch another stuck vehicle by attaching the winch cable to a suspension component, brush guard, bumper or cargo rack. Vehicle damage may result. Instead, attach the winch to a strong portion of the vehicle frame or hitch.

Winch Operation

13. Extensive winching will run down the battery on the winching vehicle. Let the winching vehicle's engine run while operating the winch to prevent the battery from running low if winching for long periods.
14. The winch motor may become hot during winch use. If you winch for more than 45 seconds, or if the winch stalls during operation, stop winching and permit the winch to cool down for 10 minutes before using it again.
15. After winching is complete, especially if winching at an angle, it may be necessary to re-distribute the winch cable across the winch drum. You will need an assistant to perform this task.
 - A. Release the clutch on the winch.
 - B. Feed out the winch cable that is unevenly bunched up in one area.
 - C. Re-engage the winch clutch.
 - D. Have an assistant pull the winch cable tightly with about 45 kg (100 lbs.) of tension using the hook strap.
 - E. Slowly winch the cable in while your assistant moves the end of the winch cable back and forth horizontally to evenly distribute the winch cable on the drum.
 - F. Doing this reduces the chances of the winch cable "wedging" itself between lower layers of winch cable.

Winch Cable Care

For your safety, always replace POLARIS winch parts (including the cable) with genuine POLARIS replacement parts available at your authorized POLARIS dealer.

WARNING! Use of worn or damaged cable could lead to sudden failure and SEVERE INJURY.

1. Always inspect your winch before each use. Inspect for worn or loose parts including mounting hardware. Never use the winch if any part needs repair or replacement.
2. Always inspect your winch cable before each use. Inspect for worn or kinked winch cable.
 - A. A kinked winch cable made of wire rope is shown at right. Even after being "straightened out," this cable has already been permanently and severely damaged. Promptly discontinue use of a winch cable in this condition.
 - B. A kinked winch cable made of wire rope that has been "straightened out" is shown at right. Even though it may look usable, the cable has been permanently and severely damaged. It can no longer transmit the load that it could prior to kinking. Promptly discontinue use of a winch cable in this condition.
 - C. A winch cable made of synthetic rope should be inspected for signs of fraying. Replace the cable if fraying is observed (shown at right). Promptly discontinue use of a winch cable in this condition.
 - D. Also replace the winch cable if there are fused or melted fibers. Such an area of the synthetic rope will be stiff and appear smooth or glazed. Promptly discontinue use of a winch cable in this condition.

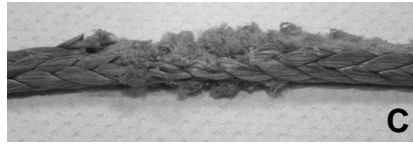

WINCH GUIDE

Shock Loading

WARNING! Your winch cable is very strong but it is NOT designed for dynamic, or “shock” loading. Shock loading may tension a winch cable beyond its strength and cause the cable to break. The end of a broken winch cable under such high loading can cause SEVERE INJURY or DEATH to you and other bystanders.

Winch cables are designed to NOT absorb energy. This is true of both wire-rope and synthetic-rope winch cables.

1. Never attempt to “jerk” a load with the winch. For example, never take up slack in the winch cable by moving the winching vehicle in an attempt to move an object. This is a dangerous practice. It generates high winch cable loads that may exceed the strength of the cable. Even a slowly moving vehicle can create large shock loads in a winch cable.

WARNING! SEVERE INJURY or DEATH can result from a broken winch cable.

2. Never quickly turn the winch ON and OFF repeatedly (“jogging”). This puts extra load on the winch, winch cable, and generates excessive heat from the motor. This is a form of shock loading.
3. Never tow a vehicle or other object with your winch. Towing an object with a winch produces shock loading of the cable even when towing at slow speeds. Towing from a winch also positions the towing force high on the vehicle. This can cause instability of the vehicle and possibly lead to an accident.
4. Never use recovery straps with your winch. Recovery straps are designed to stretch and can store energy. This stored energy in the recovery strap is released if a winch cable fails making the event even more hazardous. Similarly, never use elastic “bungie” cords for winching.
5. Never use the winch to tie down a vehicle to a trailer or other transportation vehicle. This type of use also causes shock loading that can cause damage to the winch, winch cable, or vehicles used.

Your winch cable is designed and tested to withstand the loads produced by the winch motor when operated from a stationary vehicle. Always remember that the winch and winch cable are NOT designed for shock loading.

Winch Maintenance and Service Safety

WARNING! Improper or lack of winch maintenance and service could lead to SEVERE INJURY or DEATH. Always follow all winch instructions and warnings in this manual.

1. Always inspect your winch before each use. Inspect for worn or kinked winch cable. Also inspect for worn or loose parts including mounting hardware.
2. Permit your winch motor to cool down prior to servicing your winch.
3. Never work on your winch without first disconnecting the battery connections to prevent accidental activation of the winch
4. For your safety, always replace POLARIS winch parts (including the cable) with genuine POLARIS replacement parts available at your authorized POLARIS dealer.
5. Some winch models use wire rope as the winch cable. Other winches use a specially designed synthetic rope as the winch cable.
6. Never replace a synthetic-rope winch cable with a consumer-grade polymer rope such as can be purchased in a hardware store. Although they may look similar, they are NOT alike. A polymer rope not designed for winch use will stretch and store excessive energy when winching.

WARNING! Failure of a stretched rope under winching conditions will release all of the stored energy. This will increase the chances of SEVERE INJURY or DEATH.

EMISSION CONTROL SYSTEMS

Noise Emission Control System

Do not modify the engine, intake or exhaust components, as doing so may affect compliance with governmental noise level requirements.

Spark Arrester

Your POLARIS vehicle has a spark arrester that was designed for on-road and off-road operation. It is required that this spark arrester remain installed and functional when the vehicle is operated.

Exhaust Emission Control System

Exhaust emissions are controlled by an electronic fuel injection (EFI) system. The engine and EFI components are set at the factory for optimal performance and are not adjustable.

Electromagnetic Interference

This vehicle complies with the EMC requirements of European directives 97/24/EC and 2004/108/EC.

Non-ionizing Radiation: This vehicle emits some electromagnetic energy. People with active or non-active implantable medical devices (such as heart monitoring or controlling devices) should review the limitations of their device and the applicable electromagnetic standards and directives that apply to this vehicle.

European Vibration and Noise

The driver-perceived noise and hand/arm and whole body vibration levels of this machinery is measured per prEN 15997.

The operating conditions of the machinery during testing:

The vehicles were in like-new condition. The environment was controlled as indicated by the test procedure(s).

The uncertainty of vibration exposure measurement is dependent on many factors, including:

- Instrument and calibration uncertainty
- Variations in the machine such as wear of components
- Variation of machine operators such as experience or physique
- Ability of the worker to reproduce typical work during measurements
- Environmental factors such as ambient noise or temperature

Periodic Maintenance Chart

Careful periodic maintenance will help keep your vehicle in the safest, most reliable condition. Inspection, adjustment and lubrication of important components are explained in the periodic maintenance chart.

Inspect, clean, lubricate, adjust and replace parts as necessary. When inspection reveals the need for replacement parts, use genuine POLARIS parts available from your POLARIS dealer.

Record maintenance and service in the Maintenance Log beginning on page 99.

Tip: Service and adjustments are important for proper vehicle operation. If you're not familiar with safe service and adjustment procedures, have a qualified dealer perform these operations.

Vehicles subjected to heavy or severe use patterns must be inspected and serviced more frequently.

Severe Use Definition

- Frequent immersion in mud, water or sand
- Frequent or prolonged operation in dusty environments
- Racing or race-style high RPM use
- Prolonged low speed, heavy load operation
- Extended idle
- Short trip cold weather operation

Pay special attention to the oil level. A rise in oil level during cold weather can indicate contaminants collecting in the oil sump or crankcase. Change oil immediately if the oil level begins to rise. Monitor the oil level, and if it continues to rise, discontinue use and determine the cause or see your dealer.

Maintenance Chart Key

► Perform these operations more often for vehicles subjected to severe use.

D Have an authorized POLARIS dealer perform these services.

WARNING! Improperly performing the procedures marked with a “**D**” could result in component failure and lead to serious injury or death. Have an authorized POLARIS dealer perform these services.

MAINTENANCE

Periodic Maintenance Chart

Perform all services at whichever maintenance interval is reached first.

Item	Maintenance Interval (whichever comes first)			Remarks
	Hours	Calendar	km (Miles)	
Steering	-	Pre-Ride	-	Make adjustments as needed. See Pre-Ride Checklist on page 38.
Front suspension				
Rear suspension				
Tires				
Brake fluid level				
Brake pedal travel				
Brake system				
Wheels/fasteners				
Frame fasteners				
Engine oil level				
▶ Air filter, pre-filter				
Coolant	-	Daily	-	Check level
▶ Power steering unit (if equipped)	-	Daily	-	Inspect daily; clean often
Headlamp/tail lamp	-	Daily	-	Check operation; apply dielectric grease to electrical connections if replacing lamps
▶ Air filter	-	Weekly	-	Inspect; replace as needed
▶ Brake pad wear	10 H	Monthly	-	Inspect periodically
D Battery	20 H	Monthly	-	Check terminals; clean; test
Fuel System	20 H	Monthly	-	Inspect; cycle key to pressurize fuel pump; check lines and fittings for leaks and abrasion
▶ Engine breather	25 H	1 M	-	Inspect; replace as needed
▶ Front Gearcase oil (if equipped)	25 H	1 M	-	Perform a break-in oil level check
▶ Middle Gearcase oil (if equipped)	25 H	1 M	-	Perform a break-in oil level check
▶ Rear gearcase oil (if equipped)	25 H	1 M	-	Perform a break-in oil level check
▶ Transmission oil	25 H	1 M	-	Perform a break-in oil level check
▶ Engine oil change (break-in)	25 H	1 M	-	Perform a break-in oil change at one month
▶ General lubrication	50 H	3 M	-	Lubricate all fittings, pivots, cables, etc.
Shift Linkage	50 H	6 M	-	Inspect, lubricate, adjust
D Steering	50 H	6 M	-	Lubricate
▶ Front Suspension	50 H	6 M	-	Lubricate
▶ Rear Suspension	50 H	6 M	-	Lubricate
D Throttle cable/Release switch	50 H	6 M	800 (500)	Inspect; adjust; lubricate; replace if necessary
Throttle body air intake ducts/flange	50 H	6 M	800 (500)	Inspect duct for proper sealing/air leaks
Drive belt	50 H	6 M	800 (500)	Inspect; adjust; replace as needed

▶ Perform these procedures more often for vehicles subjected to severe use.

D Have an authorized POLARIS dealer perform these services.

Periodic Maintenance Chart

Item	Maintenance Interval (whichever comes first)			Remarks
	Hours	Calendar	km (Miles)	
Cooling system (if applicable)	50 H	6 M	-	Inspect coolant strength seasonally; pressure test system yearly
▶ Oil lines, fasteners	50 H	6 M	-	Inspect for leaks and loose fittings
▶ Engine oil and filter change	100 H	6 M	1600 (1000)	Change oil and filter; (perform a break-in oil change at one month)
▶ Front Gearcase oil (if equipped)	100 H	6 M	-	Inspect level; change yearly
▶ Middle Gearcase oil (if equipped)	100 H	6 M	-	Inspect level; change yearly
▶ Rear gearcase oil (if equipped)	100 H	6 M	-	Inspect level; change yearly
▶ Transmission oil	100 H	12 M	1600 (1000)	Change fluid
D Fuel system	100 H	12 M	1600 (1000)	Cycle key to pressurize fuel pump; check for leaks at fill cap, fuel lines/rail and fuel pump; replace lines every two years
▶ Radiator (if applicable)	100 H	12 M	-	Inspect; clean external surfaces
▶ Cooling Hoses	100 H	12 M	-	Inspect for leaks
▶ Engine mounts	100 H	12 M	-	Inspect
Exhaust muffler/pipe	100 H	12 M	-	Inspect
▶ Spark plug	100 H	12 M	1600 (1000)	Inspect; replace as needed
D Ignition timing	100 H	12 M	-	Inspect
▶ Wiring	100 H	12 M	-	Inspect for wear, routing, security; apply dielectric grease to connectors subjected to water, mud, etc.
D Clutches	100 H	12 M	1600 (1000)	Inspect; clean; replace worn parts
D Front wheel bearings	100 H	12 M	-	Inspect; replace as needed
D Brake fluid	200 H	24 M	-	Change every two years
▶ Spark arrester	300 H	36 M	-	Clean out
▶ Coolant	-	60 M	-	Replace coolant
Valve clearance	500 H	-	8000 (5000)	Inspect; adjust as needed
Idle speed		-		Adjust as needed
D Toe adjustment		-		Inspect periodically; adjust when parts are replaced
D Auxiliary brake (if equipped)		-		Inspect daily; adjust as needed
▶ Headlight aim		-		Adjust as needed

Lubrication Recommendations

Check and lubricate all components at the intervals outlined in the Periodic Maintenance Chart beginning on page 61, or more often under severe use, such as wet or dusty conditions. Items not listed in the chart should be lubricated at the general lubrication interval.

Item	Lube	Method
Engine Oil	PS-4 5W-50 4-Cycle Oil	See page 64
Brake Fluid	DOT 4 Brake Fluid	See page 76.
Main Gearcase Oil (Transmission)	AGL Gearcase Lubricant & Transmission Fluid	See page 66.
Front Gearcase Oil	Demand Drive Fluid	See page 67.
Front Prop Shaft Yoke	U-Joint Grease	Locate fittings and grease (3 pumps maximum).

MAINTENANCE

Engine Oil (570)

Always check and change the oil at the intervals outlined in the Periodic Maintenance Chart beginning on page 61. Always use the recommended engine oil. See page 63.

NOTICE: Allowing dirt or debris to enter the engine can result in serious engine damage. Always clean away all dirt and debris from the dipstick area before removing the dipstick.

Oil Check

The oil dipstick and fill tube is located on the engine. Access the dipstick through the right rear wheel well.

1. Position the vehicle on a level surface.
2. Place the transmission in PARK.
3. Always clean away all dirt and debris from the dipstick area before removing the dipstick. Remove the dipstick. Wipe it dry with a clean cloth.
4. Reinstall and tighten the dipstick.
5. Remove the dipstick and check the oil level.
6. Add the recommended fluid as needed. Maintain the oil level in the safe range between the FULL and ADD marks. Do not overfill.
7. Reinstall and tighten the dipstick.

Oil and Filter Change

Always check and change the oil at the intervals outlined in the Periodic Maintenance Chart beginning on page 61. Always change the oil filter whenever changing oil.

The engine drain plug is located on the bottom of the crankcase.

1. Position the vehicle on a level surface. Place the transmission in PARK. Apply the brakes.
2. Start the engine. Allow it to idle for two to three minutes. Stop the engine.

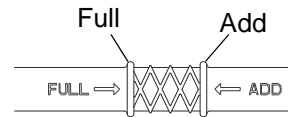
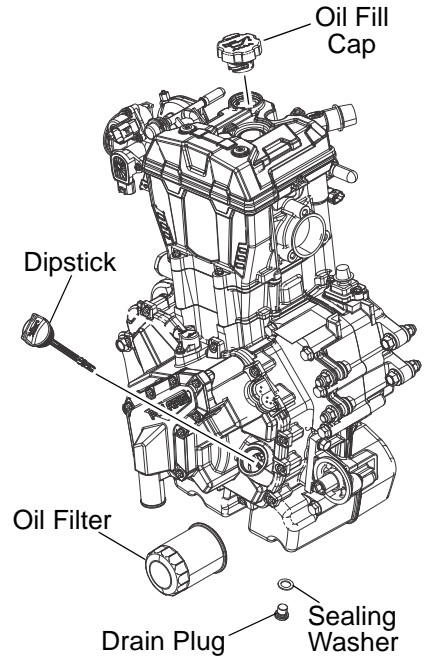

Engine Oil (570) Oil and Filter Change

3. Clean the area around the drain plug.

CAUTION! Hot oil can cause burns to skin. Do not allow hot oil to contact skin.

4. Place a drain pan beneath engine crankcase and remove the drain plug.
5. Allow the oil to drain completely.
6. Reinstall the sealing washer on the drain plug.

Tip: The sealing surfaces on drain plug and crankcase should be clean and free of burrs, nicks or scratches.

7. Reinstall the drain plug. Torque to 16 Nm (12 ft. lbs.).
8. Using a cap-style oil filter wrench, turn the filter counter-clockwise to remove it.
9. Using a clean dry cloth, clean the filter sealing surface on the crankcase. Make sure the old filter o-ring is completely removed.
10. Lubricate the o-ring on the new filter with a film of fresh engine oil. Check to make sure the o-ring is in good condition.
11. Install the new filter and turn by hand until the filter gasket contacts the sealing surface, then turn an additional 3/4 turn.
12. Always clean away all dirt and debris from the dipstick area before removing the dipstick. Remove the dipstick (or the oil fill cap on the top of the engine) and fill the sump with 1.9 liters (2 qts.) of recommended oil.
13. Reinstall and tighten the dipstick.
14. Make sure the transmission is in PARK. Apply the brakes.
15. Start the engine. Allow it to idle for one to two minutes.
16. Stop the engine. Inspect for leaks.
17. Re-check the oil level on the dipstick and add oil as necessary to bring the level to the upper mark on the dipstick.
18. Dispose of used filter and oil properly.



Drain Plug Access

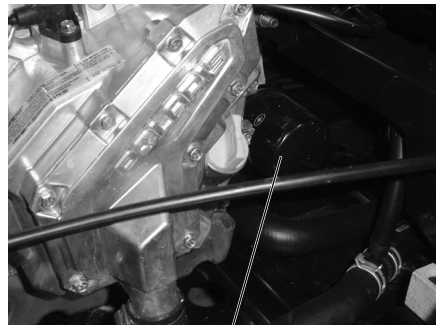

Oil Filter

MAINTENANCE

Gearcases

Gearcase Specification Chart

Gearcase	Lubricant	Capacity	Fill Plug(s) Torque	Drain Plug Torque
Main Gearcase (Transmission)	AGL Gearcase Lubricant & Transmission Fluid	1200 ml (41 oz.)	14-19 Nm	14-19 Nm
Front Gearcase	Demand Drive Fluid	275 ml (9.3 oz.)	11-13.6 Nm	15 Nm

Transmission (Main Gearcase)

Always check and change the transmission oil at the intervals outlined in the Periodic Maintenance Chart beginning on page 61. Maintain the oil level even with the bottom thread of the fill plug hole.

Refer to the Gearcase Specifications Chart for recommended lubricants, capacities and torque specifications. See page 92 for the part numbers of POLARIS products.

Fluid Check

The fill plug is located on the rear of the gearcase. Maintain the fluid level at the bottom of the fill plug hole.

1. Position the vehicle on a level surface.
2. Remove the fill plug.
3. Check the fluid level.
4. Add the recommended fluid to the bottom of the fill plug hole. Do not overfill.
5. Reinstall the fill plug. Torque to specification.

Fluid Change

The drain plug is located on the bottom of the gearcase. Access the drain plug through the hole in the skid plate.

1. Remove the fill plug.
2. Place a drain pan under the drain plug.
3. Remove the drain plug. Allow the fluid to drain completely.
4. Clean and reinstall the drain plug. Torque to specification.
5. Add the recommended fluid to the bottom of the fill plug hole. Do not overfill.
6. Reinstall the fill plug. Torque to specification.
7. Check for leaks. Discard used fluid properly.

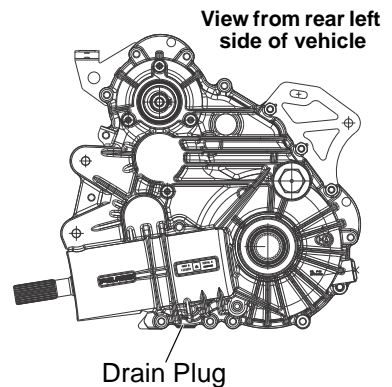
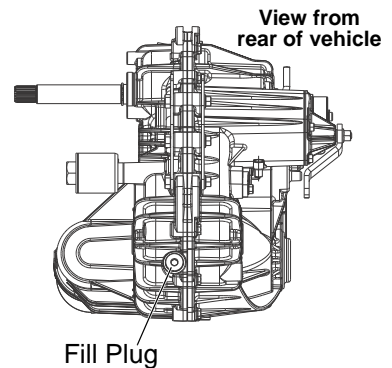

Gearcases

Front Gearcase

Always check and change the front gearcase oil at the intervals outlined in the Periodic Maintenance Chart beginning on page 61. Maintain the oil level even with the bottom thread of the fill plug hole.

Refer to the Gearcase Specifications Chart on page 66 for recommended lubricants, capacities and torque specifications. See page 92 for the part numbers of POLARIS products.

Oil Check

The front gearcase fill plug is located on the right side of the front gearcase.

1. Position the vehicle on a level surface.
2. Remove the fill plug. Check the oil level.
3. Add the recommended oil as needed.
4. Reinstall the fill plug. Torque to specification.

Oil Change

1. Support the vehicle securely with a jackstand.
2. Remove the front tire on the driver's side.
3. Remove the fill plug.
4. Place a drain pan under the drain plug on the bottom right-hand side.
5. Remove the drain plug. Drain the oil.
6. Clean and reinstall the drain plug. Torque to specification.
7. Add the recommended fluid to the bottom of the fill plug hole. Do not overfill.
8. Reinstall the fill plug. Torque to specification.
9. Check for leaks.
10. Discard used oil properly.

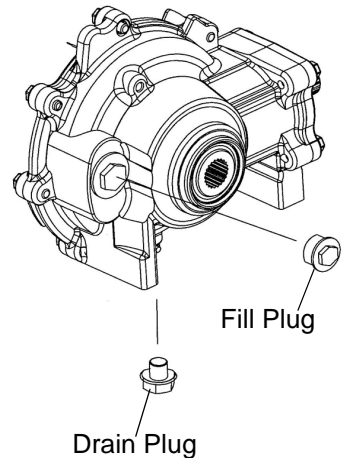

MAINTENANCE

Spark Plugs

Spark Plug Recommendations

Refer to the specifications section beginning on page 90 for the recommended spark plug type for your vehicle. Always torque spark plugs to specification.

NOTICE: Using non-recommended spark plugs can result in serious engine damage. Always use POLARIS-recommended spark plugs.

Spark Plug Gap/Torque

Model	Electrode Gap	New or Used Plug Torque
RANGER 570/570 EPS	.7-.9 mm	12 Nm

Spark Plug Inspection

Spark plug condition is indicative of engine operation. The spark plug firing end condition should be read after the engine is warmed up and the vehicle is driven at higher speeds. Immediately check the spark plug for correct color.

CAUTION! A hot exhaust system and engine can cause burns. Wear protective gloves when removing a spark plug for inspection.

1. Lift the cargo box to access the spark plugs.
2. Remove the spark plug cap. Using the spark plug wrench provided in the tool kit, remove the plug by rotating it counter-clockwise.
3. Reverse the procedure for spark plug installation.
4. Torque to specification.

Normal Plug

The normal insulator tip is gray, tan or light brown. There will be few combustion deposits. The electrodes are not burned or eroded. This indicates the proper type and heat range for the engine and the service.

The tip should not be white. A white insulator tip indicates overheating, caused by use of an improper spark plug or incorrect throttle body adjustments.

Wet Fouled Plug

The wet fouled insulator tip is black. A damp oil film covers the firing end. There may be a carbon layer over the entire nose. Generally, the electrodes are not worn. General causes of fouling are excessive oil or incorrect throttle body adjustments.

Cooling System

The engine coolant level is controlled or maintained by the recovery system. The recovery system components are the overflow bottle, radiator filler neck, radiator pressure cap and connecting hose.

As coolant operating temperature increases, the expanding (heated) excess coolant is forced out of the radiator, past the pressure cap, and into the overflow bottle. As engine coolant temperature decreases, the contracting (cooled) coolant is drawn back up from the tank, past the pressure cap, and into the radiator.

Some coolant level drop on new vehicles is normal as the system is purging itself of trapped air. Observe coolant levels and maintain as recommended by adding coolant to the overflow bottle.

Adding or Changing Coolant

POLARIS recommends the use of POLARIS Antifreeze 50/50 Premix. This antifreeze is already premixed and ready to use. Do not dilute with water. See page 92 for the part numbers of POLARIS products.

To ensure that the coolant maintains its ability to protect the engine, we recommend that the system be completely drained every five (5) years and fresh Antifreeze 50/50 Premix added.

Any time the cooling system has been drained for maintenance or repair, replace the coolant with fresh Antifreeze 50/50 Premix. If the recovery bottle has run dry, the level in the radiator should be inspected. Add coolant as needed.

Radiator and Cooling Fan

Always check and clean the screen and radiator fins at the intervals outlined in the Periodic Maintenance Chart beginning on page 61. Do not obstruct or deflect air flow through the radiator by installing unauthorized accessories in front of the radiator or behind the cooling fan. Interference with the radiator air flow can lead to overheating and consequent engine damage.

NOTICE: Washing the vehicle with a high-pressure hose could damage the radiator fins and impair the radiator's effectiveness. Using a high-pressure system is not recommended.

MAINTENANCE

Cooling System

Overflow Bottle Coolant Level

Always check and change the coolant at the intervals outlined in the Periodic Maintenance Chart beginning on page 61. Maintain the coolant level between the minimum and maximum marks on the bottle (when the fluid is cool).

1. Position the vehicle on a level surface.
2. Lift the hood. View the coolant level in the overflow bottle.
3. If the coolant level is below the safe operating range, lift the hood and locate the overflow bottle lid. Remove the cap and use a funnel to add coolant through the filler opening. Reinstall the cap.

Tip: If coolant must be added often, or if the overflow bottle runs completely dry, there may be a leak in the system. Have the cooling system inspected by your POLARIS dealer.

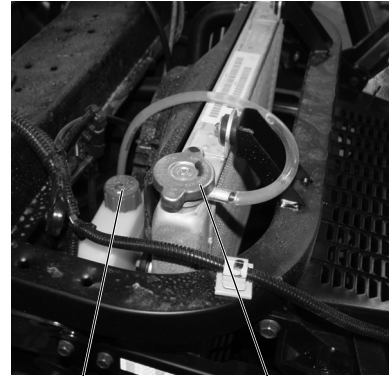

Overflow
Bottle Cap

Radiator
Cap

Radiator Coolant Level

Always check and clean the screen and radiator fins at the intervals outlined in the Periodic Maintenance Chart beginning on page 61. Do not obstruct or deflect air flow through the radiator by installing unauthorized accessories in front of the radiator or behind the cooling fan. Interference with the radiator air flow can lead to overheating and consequentially, engine damage.

1. Lift the hood.

CAUTION! Escaping steam can cause burns. Never remove the pressure cap while the engine is warm or hot. Always allow the engine to cool before removing the pressure cap.

2. Slowly remove the radiator cap.
3. View the coolant level through the opening.
4. Use a funnel and slowly add coolant as needed.

Tip: This procedure is required only if the cooling system has been drained for maintenance and/or repair. But if the overflow bottle has run dry, the level in the radiator should also be inspected.

5. Reinstall the pressure cap. Use of a non-standard pressure cap will not allow the recovery system to function properly. See your dealer for the correct replacement part.

POLARIS Variable Transmission (PVT) System

⚠ WARNING

Failure to comply with the instructions in this warning can result in severe injury or death.

Do not modify any component of the PVT system. Doing so may reduce its strength so that a failure may occur at a high speed. The PVT system has been precision balanced. Any modification will cause the system to be out of balance, creating vibration and additional loads on components.

The PVT system rotates at high speeds, creating large amounts of force on clutch components. As the owner, you have the following responsibilities for your own safety and the safety of others:

- Always follow all recommended maintenance procedures. Always look for and remove debris inside and around the clutch and vent system when replacing the belt.
- See your dealer as outlined in the owner's manual.
- This PVT system is intended for use on POLARIS products only. Do not install it in any other product.
- Always make sure the PVT housing is securely in place during operation.

Belt Replacement/Debris Removal

If a belt fails, always clean any debris from the clutch air duct and from the clutch and engine compartments when replacing the belt.

WARNING! Failure to remove ALL debris when replacing the belt could result in vehicle damage, loss of control and severe injury or death.

1. Position the vehicle on a level surface. Block the wheels to prevent vehicle movement. Place the transmission in neutral.
2. Lift the cargo box.
3. Remove the clutch cover screws using a 3/8" socket with ratcheting wrench and extension.
4. Pull the bottom of the cover outward and over the suspension to remove it.
5. Make sure the cover gasket does not fall out of the groove when removing the cover.
6. Squeeze the belt together so that it submerges further into the driven clutch, creating slack in the belt between the clutches.
7. Remove the belt by using the slack to pull part of the belt off the driven clutch.



Step 3



Step 5



Step 6



Step 7

MAINTENANCE

POLARIS Variable Transmission (PVT) System

Belt Replacement/Debris Removal

8. Rotate the driven clutch by hand until the belt is completely off.



Step 8

9. Slide the front of the belt out from between the drive clutch and inner clutch cover to completely remove it.
10. Remove all debris wrapped in and around the PVT system.
11. Remove all debris from the entire clutch air duct passage.
12. Check for signs of damage to seals on the transmission and engine. See your dealer promptly for service if any seals appear to be damaged.



Step 9

Tip: Belt slip is responsible for creating excessive heat that destroys belts, wears clutch components and causes outer clutch covers to fail. Switch to low range while operating at slower speeds to extend the life of the PVT components (belt, cover, etc.).

13. To install a belt, place one end of the belt over the driving clutch. Route the belt over the top of the driven clutch and down into the groove of the clutch to allow slack in the belt. Rotate the driven clutch by hand until the belt falls into place.
14. Reinstall the clutch cover in the reverse order of removal, fitting the top of the cover into place, then working the bottom of the cover over the suspension.
15. Install all clutch cover screws. Torque to 5.5-6.5 Nm (4-5 ft. lbs.).

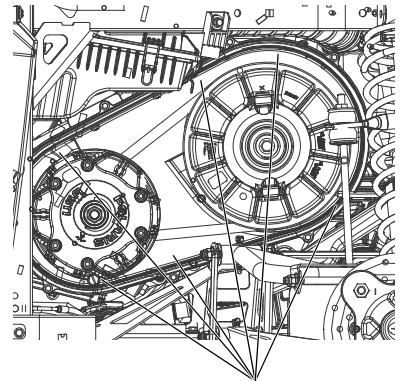

Remove ALL Debris

POLARIS Variable Transmission (PVT) System

PVT Drying

There may be some instances when water is ingested into the PVT system. Use the following instructions to dry it out before operating.

1. Position the vehicle on a level surface.
2. Remove the red drain plug on the outer clutch cover. Allow the water to drain completely. Reinstall the drain plug.
3. Place the transmission in PARK.
4. Start the engine.
5. Apply varying throttle for 10-15 seconds to expel the moisture and air-dry the belt and clutches. Do not hold the throttle wide open for more than five (5) seconds.
6. Allow the engine RPM to settle to idle speed. Apply the brakes. Shift the transmission to the lowest available range.
7. Test for belt slippage. If the belt slips, repeat the process.
8. Take the vehicle to your dealer for service as soon as possible.

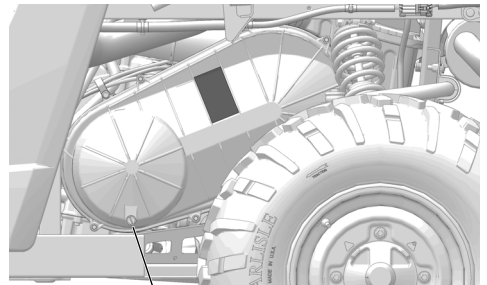

Drain Plug

Vehicle Immersion

NOTICE: If your vehicle becomes immersed, major engine damage can result if the machine is not thoroughly inspected. Take the vehicle to your dealer before starting the engine.

If it's impossible to take your *RANGER* to a dealer before starting it, follow the steps outlined below.

1. Move the vehicle to dry land or at the very least, to water below the footrests.
2. Dry any water present in the air box. Filter replacement is required if water is present.
3. Remove the spark plugs. Turn the engine over several times using the electric start.
4. Dry the spark plugs and reinstall, or replace with new plugs.
5. Attempt to start the engine. If necessary, repeat the drying procedure.
6. Take the vehicle to your dealer for service as soon as possible, whether you succeed in starting it or not.
7. If water has been ingested into the PVT follow the procedure on page 73 for drying.

MAINTENANCE

Filter Systems

Air Filter

Always change the air filter at the intervals outlined in the Periodic Maintenance Chart beginning on page 61.

1. Lift the cargo box.
 2. Clean all dirt and debris from the air box area.
 3. Unlatch the two (2) cover clips and carefully remove the air box cover. Inspect the seal between the cover and air box to ensure the seal is not torn and has been maintaining a proper seal.
 4. Inspect the air filter and air box for dirt, debris, oil or water. If the filter needs to be replaced, remove the worm gear clamp from the filter neck with a flat-blade screwdriver or 6mm socket. Slide the filter rearward to remove it from the boot, then lift it straight upward and out of the air box.
 5. With the filter removed, clean the intake boot and air box thoroughly and wipe well with a clean, dry cloth.
- NOTICE:** Dirt or debris in the intake boot could result in severe engine damage. Always clean all dirt and debris from the intake boot before installing the filter.
6. Reinstall the air filter (if clean) or install a new air filter (if soiled). Do not attempt to clean the air filter.
- NOTICE:** Use of a non-POLARIS-approved air filter may cause engine damage. Always use a POLARIS-approved replacement filter. See page 92 for the part numbers of POLARIS products.
7. Make sure the filter is fully seated on the intake boot and that there is no gap between the filter and boot after installation. Tighten the worm gear clamp to 2.7 Nm (24 in. lbs.).
 8. Reinstall the air box cover. Make sure both hinges are fully inserted. Secure the cover clips.

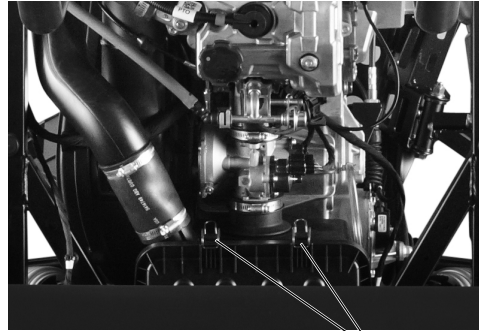

View of Under-Box Area

Cover Clips

Spark Arrester

⚠ WARNING

Failure to heed the following warnings while servicing the spark arrester could result in serious injury or death.

- Do not perform service on the spark arrester while the system is hot. Exhaust system temperatures can reach 1000° F. Allow components to cool sufficiently before proceeding.
- Remove any combustible materials from the area.
- Wear eye protection and gloves.
- Do not stand behind or in front of the vehicle while purging.
- Never run the engine in an enclosed area. Exhaust contains poisonous carbon monoxide gas that can cause loss of consciousness or death in a very short time.
- Never operate without the spark arrester.
- Never go under the vehicle while it's inclined.

Use the following procedure to periodically purge accumulated carbon from the exhaust pipe.

1. Remove the arrester clean-out plug located on the bottom of the muffler.
2. Place the transmission in PARK.
3. Start the engine.
4. Purge accumulated carbon from the system by momentarily revving the engine several times.
5. If carbon is expelled, cover or plug the exhaust outlet and rap on the pipe around the clean-out plug while revving the engine several more times.
6. If particles are still suspected to be in the muffler, elevate the rear of the vehicle one foot higher than the front. Block the wheels.
7. Repeat steps 4 and 5 until no more particles are expelled when the engine is revved.
8. Stop the engine. Allow the arrester to cool.
9. Reinstall the arrester plug and remove the outlet cover or plug.

MAINTENANCE

Brakes

The front and rear brakes are hydraulic disc type brakes. Press down on the brake pedal to engage the brakes. See page 26.

Brake Fluid

Inspect the brake system routinely. Inspect the level of the brake fluid before each operation.

WARNING! After opening a bottle of brake fluid, always discard any unused portion. Never store or use a partial bottle. Brake fluid is hygroscopic, meaning it rapidly absorbs moisture from the air. The moisture causes the boiling temperature of the brake fluid to drop, which can lead to early brake fade and the possibility of accident or severe injury.

Change the brake fluid every two years and any time the fluid becomes contaminated, the fluid level is below the minimum, or if the type and brand of the fluid in the reservoir are unknown. See page 63 for fluid recommendations.

1. Position the vehicle on a level surface.
2. View the brake fluid level at the reservoir in the driver's side wheel well. The level should be between the upper (MAX) and lower (MIN) level lines.
3. If the fluid level is lower than the upper level line, open the hood and add brake fluid to the upper (MAX) line.
4. Apply the brake forcefully for a few seconds and check for fluid leakage around the fittings.

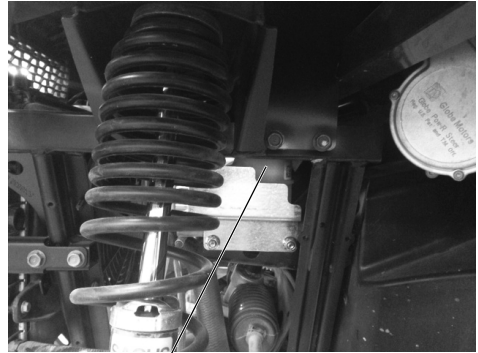

Brake Fluid Reservoir

Brake Inspection

1. Check the brake system for fluid leaks.
2. Check the brake pedal for excessive travel or a spongy feel.
3. Check the friction pads for wear, damage and looseness.
4. Check brake discs for signs of cracks, excessive corrosion, warping or other damage. Clean any grease using an approved brake cleaner or alcohol.

WARNING! Do not apply WD-40 or any petroleum product to brake discs. These types of products are flammable and may also reduce the friction between the brake pad and caliper.

5. Inspect the brake disc spline and pad wear surface for excessive wear. Change pads when worn to 0.762 mm.

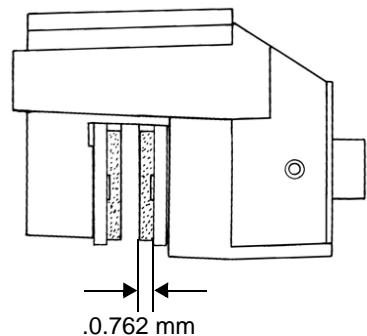

Steering Wheel Inspection

Check the steering wheel for specified freeplay and smooth operation at the intervals outlined in the Periodic Maintenance Chart beginning on page 61.

1. Position the vehicle on a level surface.
2. Lightly turn the steering wheel left and right.
3. There should be 20-25 mm of freeplay.
4. If there is excessive freeplay or strange noises, or the steering feels rough or “catchy”, have the steering system inspected by an authorized POLARIS dealer.

Spring Adjustment

Adjust the front and rear shock absorber springs by rotating the adjustment cam either clockwise or counter-clockwise to increase or decrease spring tension.

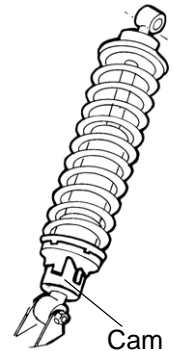

MAINTENANCE

Tires

⚠ WARNING

Operating your vehicle with worn tires, improperly inflated tires, non-standard tires or improperly installed tires will affect vehicle handling and could cause an accident resulting in serious injury or death. Always follow all tire maintenance procedures as outlined in this manual and on the labels on the vehicle. Always use POLARIS-approved size and type of tires for this vehicle when replacing tires.

Tire Tread Depth

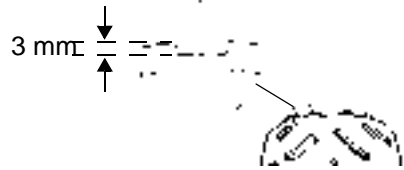

Always replace tires when tread depth is worn to 3 mm or less.



Axle and Wheel Nut Torque Specifications

Inspect the following items occasionally for tightness, and if they've been loosened for maintenance service.

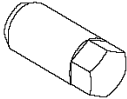
Do not lubricate the stud or the lug nut.

Nut Type	Location	Nut Torque
Lug Nut (Aluminum Wheels) 	Front and Rear	41 Nm (30 ft. lbs.) +90° (1/4 Turn)
Nut and Washer (Steel Wheels) 	Front and Rear	47 Nm (35 ft. lbs.)
Spindle Nut	Front	95 Nm (70 ft. lbs.)
Hub Retaining Nuts	Rear	150 Nm (110 ft. lbs.)
	Front	108.5 Nm (80 ft. lbs.)

Tires

Wheel Removal

1. Apply the brakes.
2. Place the transmission in PARK.
3. Stop the engine.
4. Loosen the wheel nuts slightly.
5. Elevate the side of the vehicle by placing a suitable stand under the frame.
6. Remove the wheel nuts and washers. Remove the wheel.

Wheel Installation

1. Place the transmission in PARK.
2. Place the wheel in the correct position on the wheel hub. Be sure the valve stem is toward the outside and rotation arrows on the tire point toward forward rotation.

WARNING! Improperly installed wheels can adversely affect tire wear and vehicle handling, which can result in serious injury or death. Always ensure that all nuts are torqued to specification. Do not service axle nuts that have a cotter pin installed. See your POLARIS dealer.

3. Attach the wheel nuts and washers and finger tighten.
4. Carefully lower the vehicle to the ground.
5. Torque the wheel nuts to specification. See page 78.

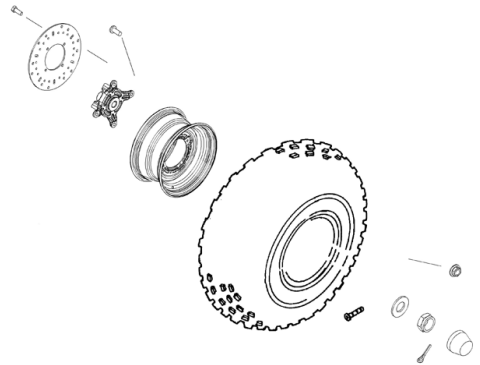

Power Steering Unit

If your model is equipped with power steering, frequently clean the areas around and on the power steering unit to allow proper cooling. Clean these areas thoroughly.

MAINTENANCE

Fuses

If the engine stops or will not start, or if you experience other electrical failures, a fuse may need replacement. Locate and correct any short circuits that may have caused the blown fuse, then replace the fuse.

The fuse box is located in the electrical compartment under the driver's seat. Spare fuses are provided in the fuse box.

If you suspect that a fuse or relay may not be working properly, please see your POLARIS dealer.

Lights

Poor lighting can result in reduced visibility when driving. Headlight and taillight lenses become dirty during normal operation. Clean lights frequently and replace burned out lamps promptly. Do not operate this vehicle at night or in low light conditions until the headlight is replaced. Always make sure lights are adjusted properly for best visibility.

When servicing a halogen lamp, don't touch the lamp with bare fingers. Oil from your skin leaves a residue, causing a hot spot that will shorten the life of the lamp.

Headlight Lamp Replacement

1. Access the headlamp wiring harnesses through the front wheel wells.
2. Unplug the headlamp from the two wiring harnesses. Be sure to pull on the connector, not on the wiring.
3. Turn the lamp counter-clockwise to remove it.
4. Install the new lamp.

Tip: Make sure the tab on the lamp locates properly in the housing.

5. Reinstall the two harness assemblies into the headlight assembly.

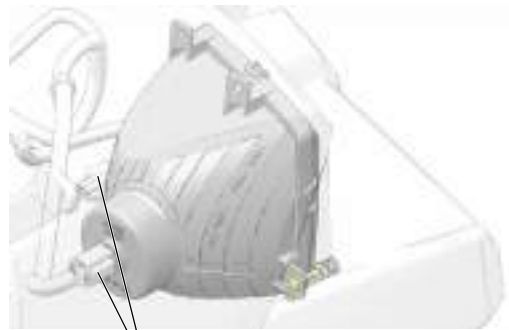

Connectors

Lights

Headlight Beam Adjustment

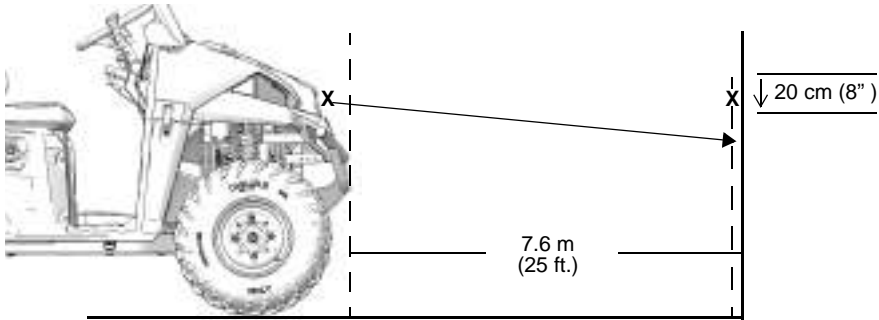

1. Position the vehicle on a level surface with the headlight approximately 7.6 m (25 ft.) from a wall.
2. Place the transmission in PARK.
3. Measure the distance from the floor to the center of the headlight and make a mark on the wall at the same height.
4. Apply the brakes. Start the engine. Turn on the headlights.
5. Observe the headlight aim. The most intense part of the headlight beam should be aimed 20 cm (8 in.) below the mark placed on the wall. Include the weight of a rider on the seat while performing this step.
6. If a headlight needs adjustment, locate the (3) three adjustment screws at the rear of the headlight.
7. Loosen the screws, adjust the beam to desired position, then tighten the screws.
8. Repeat steps 5-7 until the lamp is properly adjusted.

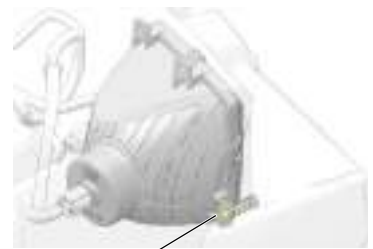

Adjustment Screw

Brake Lights

When the brake pedal is depressed, the brake light comes on. Check the brake light before each ride.

1. Turn the ignition switch to the ON position.
2. Depress the brake pedal. The brake light should come on after about 10 mm (0.4 in.) of pedal travel. If the light doesn't come on, check the bulb.

Taillight/Brake Light/Turn Signal Lamp Replacement

The taillight assembly is not serviceable. If the taillight or brake light fails to operate properly, replace the entire taillight assembly.

Front Turn Signal Lamp Replacement

If a front turn signal light becomes inoperable, the lamps cannot be replaced. Replace the entire signal lamp assembly.

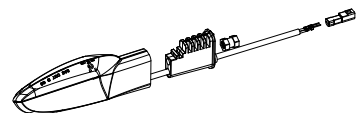

MAINTENANCE

Battery

⚠ WARNING

Battery electrolyte is poisonous. It contains sulfuric acid. Serious burns can result from contact with skin, eyes or clothing.

Antidote:

External: Flush with water.

Internal: Drink large quantities of water or milk. Follow with milk of magnesia, beaten egg, or vegetable oil. Call physician immediately.

Eyes: Flush with water for 15 minutes and get prompt medical attention.

Batteries produce explosive gases. Keep sparks, flame, cigarettes, etc. away. Ventilate when charging or using in an enclosed space. Always shield eyes when working near batteries. **KEEP OUT OF REACH OF CHILDREN.**

Your vehicle may have either a sealed battery, which requires little maintenance, or a conventional battery. A sealed battery can be identified by its flat covers on the top of the battery. A conventional battery has six filler caps on the top of the battery.

Always keep battery terminals and connections free of corrosion. If cleaning is necessary, remove the corrosion with a stiff wire brush. Wash with a solution of one tablespoon baking soda and one cup water. Rinse well with tap water and dry off with clean shop towels. Coat the terminals with dielectric grease or petroleum jelly. Be careful not to allow cleaning solution or tap water into the battery.

Battery Fluid (Conventional Battery)

A poorly maintained battery will deteriorate rapidly. Check the battery fluid level often. Maintain the fluid level between the upper and lower level marks.

Add only distilled water. Tap water contains minerals that are harmful to a battery.

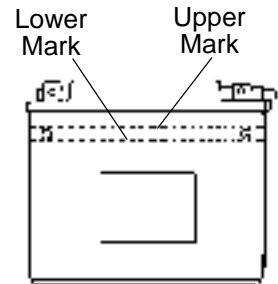

Battery

Battery Removal

⚠ WARNING

Improperly connecting or disconnecting battery cables can result in an explosion and cause serious injury or death. When removing the battery, always disconnect the negative (black) cable first. When reinstalling the battery, always connect the negative (black) cable last.

1. Remove the seat to access the battery compartment.
2. On conventional batteries, remove the battery vent tube.
3. Disconnect the black (-) battery cable first. Disconnect the red (+) battery cable last.
4. Remove the battery hold-down strap.
5. Lift the battery out of the vehicle. Be careful not to tip a conventional battery sideways, which could spill electrolyte.



NOTICE: If electrolyte spills, immediately wash it off with a solution of one tablespoon baking soda and one cup water to prevent damage to the vehicle.

MAINTENANCE

Battery

Battery Installation

Using a new battery that has not been fully charged can damage the battery and result in a shorter life. It can also hinder vehicle performance. Follow the battery charging instructions on page 85 before installing the battery.

If your factory-installed 14 AH battery cannot maintain a charge because of operation in extreme cold or with multiple electrical accessories, please see your POLARIS dealer to purchase a 30 AH battery. Before installing the 30 AH battery, remove the plastic spacer at the bottom of the battery compartment. Save the spacer for future use.

1. Ensure that the battery is fully charged.
2. Place the fully charged battery in the battery holder.
3. With conventional batteries, install the battery vent tube (sealed batteries do not have a vent tube). The vent tube must be free of obstructions and securely installed. Route the tube away from the frame and vehicle body to prevent contact with electrolyte.

WARNING! Battery gases could accumulate in an improperly installed vent tube and cause an explosion, resulting in serious injury or death. Always ensure that the vent tube is free of obstructions and is securely installed as recommended.

4. Coat the terminals with dielectric grease or petroleum jelly.
5. Connect and tighten the red (+) cable first. Connect and tighten the black (-) cable last.
6. Verify that cables are properly routed. Cables should be safely tucked away at the front and rear of the battery.
7. Install the battery hold-down strap.

Battery Storage

Whenever the vehicle is not used for a period of three months or more, remove the battery from the vehicle, ensure that it's fully charged, and store it out of the sun in a cool, dry place. Check battery voltage each month during storage and recharge as needed to maintain a full charge. See page 85.

POLARIS recommends maintaining battery charge by using a POLARIS Battery Tender charger or by charging about once a month to make up for normal self-discharge. Battery Tender can be left connected during the storage period, and will automatically charge the battery if the voltage drops below a pre-determined point. See page 92 for the part numbers of POLARIS products.

Battery

Battery Charging (Conventional Battery)

1. Remove the battery from the vehicle to prevent damage from leaking or spilled electrolyte during charging. See page 83.
2. Charge the battery with a charging output no larger than 1/10 of the battery's amp/hr rating. Charge as needed to raise the specific gravity to 1.270 or greater.
3. Reinstall the battery. See page 84. Make sure the positive terminal is toward the driver's side of the vehicle.

Battery Charging (Sealed Battery)

The following battery charging instructions apply only to the installation of a sealed battery. Read all instructions before proceeding with the installation of this battery.

The sealed battery is already filled with electrolyte and has been sealed and *fully charged* at the factory. *Never* pry the sealing strip off or add any other fluid to this battery.

The single most important thing about maintaining a sealed battery is to keep it fully charged. Since the battery is sealed and the sealing strip cannot be removed, you must use a voltmeter or multimeter to measure DC voltage.

WARNING! An overheated battery may explode, causing severe injury or death. Always watch charging times carefully. Stop charging if the battery becomes very warm to the touch. Allow it to cool before resuming charging.

For a refresh charge, follow all instructions carefully.

1. Check the battery voltage with a voltmeter or multimeter. A fully charged battery will register 12.8 V or higher. If the voltage is less than 12.8 volts, recharge the battery at 1.2 amps or less until battery voltage is 12.8 or greater.
2. When using an automatic charger, refer to the charger manufacturer's instructions for recharging. When using a constant current charger, use the guidelines below for recharging.

Always verify battery condition before and 1-2 hours after the end of charging.

State of Charge	Voltage	Action	Charge Time (Using constant current charger @ standard amps specified on top of battery)
100%	12.8-13.0 volts	None, check at 3 mos. from date of manufacture	None required
75%-100%	12.5-12.8 volts	May need slight charge, if no charge given, check in 3 months	3-6 hours
50%-75%	12.0-12.5 volts	Needs charge	5-11 hours
25%-50%	11.5-12.0 volts	Needs charge	At least 13 hours, verify state of charge
0%-25%	11.5 volts or less	Needs charge with desulfating charger	At least 20 hours

MAINTENANCE

Cleaning and Storage

Washing the Vehicle

Keeping your POLARIS vehicle clean will not only improve its appearance but it can also extend the life of various components.

NOTICE: High water pressure may damage components. POLARIS recommends washing the vehicle by hand or with a garden hose, using mild soap.

NOTICE: Certain products, including insect repellents and chemicals, will damage plastic surfaces. Do not allow these types of products to contact the vehicle.

The best and safest way to clean your POLARIS vehicle is with a garden hose and a pail of mild soap and water.

1. Use a professional-type washing cloth, cleaning the upper body first and the lower parts last.
2. Rinse with clean water frequently.
3. Dry surfaces with a chamois to prevent water spots.

Washing Tips

- Avoid the use of harsh cleaners, which can scratch the finish.
- Do not use a power washer to clean the vehicle.
- Do not use medium to heavy duty compounds on the finish.
- Always use clean cloths and pads for cleaning and polishing. Old or reused cloths and pads may contain dirt particles that will scratch the finish.
- Grease all zerk fittings immediately after washing. Allow the engine to run for a while to evaporate any water that may have entered the engine or exhaust system.

If a high pressure water system is used for cleaning (not recommended), exercise extreme caution. The water may damage components and could remove paint and labels. Avoid directing the water stream at the following items:

- Wheel bearings
- Brakes
- Switches and controls
- Radiator
- Cab and body panels
- Electrical components and wiring
- Transmission seals
- Labels and decals

If an informational or graphic label becomes illegible or comes off, contact your POLARIS dealer to purchase a replacement. Replacement *safety* labels are provided by POLARIS at no charge.

Polishing the Vehicle

POLARIS recommends the use of common household aerosol furniture polish for polishing the finish on your POLARIS vehicle. Follow the instructions on the container.

- Avoid the use of automotive products, some of which can scratch the finish of your vehicle.
- Always use clean cloths and pads for cleaning and polishing. Old or reused cloths and pads may contain dirt particles that will scratch the finish.

Cleaning and Storage

Chrome Wheel Care (if equipped)

Proper maintenance will protect chrome wheels from corrosion, preserve wheel life and ensure a “like new” appearance for many years. Chrome wheels exposed to road salt (or salt in the air in coastal areas) are more susceptible to corrosion if not properly cleaned. Clean chrome wheels more often if they're exposed to salt or other corrosive elements.

1. Wash chrome wheels frequently. Use a mild detergent. Never use abrasive cleaners on plated or painted surfaces.
2. Rinse well with clear water. Soap, detergents, salt, dirt, mud and other elements can cause corrosion.
3. Polish the clean chrome wheels periodically. Use an automotive grade chrome polish.
4. Routinely and liberally apply a weather resistant wax to each polished chrome wheel. Choose a product suitable for chrome finishes. Read and follow the product labels and instructions.

Removing Corrosion

If light rust is found on the chrome finish, use steel wool (#0000-OTT grade) to remove it. Gently rub the affected areas with the steel wool until the corrosion has been removed. Clean and polish the wheel as outlined above.

Storage Tips

NOTICE: Starting the engine during the storage period will disturb the protective film created by fogging and damage could occur. Never start the engine during the storage period.

Clean the Exterior

Make any necessary repairs and clean the vehicle as recommended. See page 86.

Stabilize the Fuel

1. Fill the fuel tank.
2. Add POLARIS Carbon Clean Fuel Treatment or POLARIS Fuel Stabilizer. Follow the instructions on the container for the recommended amount. Carbon Clean removes water from fuel systems, stabilizes fuel and removes carbon deposits from pistons, rings, valves and exhaust systems.
3. Allow the engine to run for 15-20 minutes to allow the stabilizer to disperse through the entire fuel delivery system.

Oil and Filter

Change the oil and filter. See page 64.

Air Filter / Air Box

1. Inspect and clean or replace the pre-cleaner and air filter. See page 74.
2. Clean the air box.

MAINTENANCE

Cleaning and Storage

Storage Tips

Inspect and Lubricate

Inspect all cables and lubricate all areas of the vehicle as recommended in the Periodic Maintenance Chart beginning on page 61.

Battery Maintenance

See pages 84-85 for storage and charging procedures.

Fluid Levels

Inspect the fluid levels. Add or change fluids as recommended in the Periodic Maintenance Chart beginning on page 61.

- Front and rear gearcase fluid (if equipped)
- Transmission fluid
- Brake fluid (change every two years and any time the fluid looks dark or contaminated)
- Coolant (test strength/fill)

Fog the Engine

1. Treat the fuel system with POLARIS Carbon Clean. Follow the instructions on the container. Start the engine. Allow it to idle for several minutes so the Carbon Clean reaches the injectors. Stop the engine.
2. Remove the spark plugs and add 2-3 tablespoons of engine oil. To access the plug holes, use a section of clear 1/4" hose and a small plastic squeeze bottle filled with the pre-measured amount of oil. *Do this carefully!* If you miss the plug holes, oil will drain from the spark plug cavities into the hole at the front of the cylinder head, and appear to be an oil leak.
3. Reinstall the spark plugs. Torque to specification. See page 68.
4. Apply dielectric grease to the inside of each spark plug cap and reinstall the caps onto the plugs.
5. Turn the engine over several times. Oil will be forced in and around the piston rings and ring lands, coating the cylinder with a protective film of fresh oil.
6. If POLARIS fuel system additive is not used, fuel tank, fuel lines, and injectors should be completely drained of gasoline.

Storage Area/Covers

Be sure the storage area is well ventilated. Cover the vehicle with a genuine POLARIS cover. Do not use plastic or coated materials. They do not allow enough ventilation to prevent condensation, and may promote corrosion and oxidation.

Removal from Storage

1. Check the battery electrolyte level and charge the battery if necessary. Install it in the vehicle. Make sure the battery vent hose is routed properly and that it's not pinched or restricted in any way.
2. Make sure the spark plug is tight.
3. Fill the fuel tank with fuel.
4. Check all the points listed in the Daily Pre-Ride Inspection section on page 38. *Tightness of the bolts, nuts and other fasteners should be checked by an authorized POLARIS dealer.*
5. Lubricate at the intervals outlined in the Periodic Maintenance Chart beginning on page 61.

Transporting the *RANGER*

Follow these procedures when transporting the vehicle.

1. Apply the brakes.
2. Place the transmission in PARK.
3. Stop the engine.
4. Engage the park brake.
- 5.
6. Secure the fuel cap, hood and cargo box. Ensure that the seats are attached correctly and are not loose.

WARNING! Cargo and other loose vehicle parts may fly off while transporting this vehicle. Secure or remove all cargo, and inspect the unit for loose parts prior to transport.

7. Always tie the frame of the *RANGER* to the transporting unit securely with suitable straps or rope. Do not attach tie straps to the front A-arm bolt pockets.
8. Remove the key to prevent loss during transporting.

SPECIFICATIONS

RANGER 570	
Maximum Weight Capacity (includes weight of operator, passenger, cargo, accessories)	454 kg
Dry Weight	470 kg (2X4) 488 kg (4X4) 550 kg (ZUG Models)
Vehicle Seating Capacity	2
Test GVW - Rollover Protection System (ROPS)	1247 kg per OSHA 29 CFR 1928.53
Fuel Capacity	33.3 l
Engine Oil Capacity	1.9 l
Coolant Capacity	3.5 l
Overall Length	279.4 cm
Overall Width	147.3 cm
Overall Height	185 cm
Wheelbase	185 cm
Cargo Box Dimensions (Inside)	81x107x29 cm
Ground Clearance	25.4 cm
Min. Turning Radius	381 cm
Towing Capacity	680.4 kg
Hitch Tongue Capacity	68 kg
Max. Cargo Box Load	227 kg
Engine	Dual overhead cam, 4 valve 4 stroke single cylinder
Displacement	567 cc
Bore x Stroke (mm)	99mm x 73.6mm
Alternator Output	460 W @ 3000 RPM
Compression Ratio	10:1
Starting System	Electric
Fuel System	Electronic Fuel Injection
Ignition Timing	ECU Controlled 32° +/- 2° @ 5000 RPM
Spark Plug	NGK MR7F / 0.7-0.9 mm
Lubrication System	Wet Sump
Cooling	Liquid
Front Suspension	McPherson Strut w/20.3 cm of travel
Rear Suspension	Independent, 23 cm of travel
Throttle Body Size	42 mm
Ignition System	Digital CDI

SPECIFICATIONS

Driving System Type	PVT
Shift Type	Single Lever (console)
Gear Reduction - Low	28.84:1
Gear Reduction - Reverse	25.83:1
Gear Reduction - High	13.58:1
Drive Ratio - Front	N/A (2X4) 3.818:1 (4X4)
Tire Size - Front	25 x 8 - 12
Tire Size - Rear	25 x 11 - 12
Tire Pressure - Front	69 kPa
Tire Pressure - Rear	69 kPa
Brakes, Front/Rear	Foot Activated, 4 wheel hydraulic disc
Hood Headlights	2 single beam, 50W, quartz/halogen
Taillights	10 L.E.D. (.28W)
Brake Light	10 L.E.D. (3.1W)
Indicator Light	1.0 W

Clutching

See your POLARIS dealer for clutching specifications.

POLARIS PRODUCTS

Part Number	Description
Engine Lubricant	
2870791	Fogging Oil (355 ml/12 oz. Aerosol)
2876244	PS-4 Full Synthetic 5W-50 4-Cycle Oil (.95 l)
2876245	PS-4 Full Synthetic 5W-50 4-Cycle Oil (3.8 l)
2878920	PS-4 Extreme Duty Synthetic 10W-50 4-Cycle Oil (.95 l)
2878919	PS-4 Extreme Duty Synthetic 10W-50 4-Cycle Oil (3.8 l.)
Gearcase / Transmission Lubricants	
2878068	AGL Full Synthetic Gearcase Lubricant & Transmission Fluid (.95 l)
2878069	AGL Full Synthetic Gearcase Lubricant & Transmission Fluid (3.8 l)
2877922	Demand Drive Fluid (.95 l.)
2877923	Demand Drive Fluid (3.8 l)
2870465	Pump for Gallon (3.8 l) Jug
Coolant	
2880514	Antifreeze 50/50 Premix (.95 l)
2880513	Antifreeze 50/50 Premix (3.8 l)
Grease / Specialized Lubricants	
2871312	Grease Gun Kit, All Season Grease
2871322	All Season Grease (89 ml cartridge)
2871423	All Season Grease (414 ml cartridge)
2876160	ATV Angle Drive Fluid (.95 l)
2872276	ATV Angle Drive Fluid (9.5 l)
2871460	Premium Starter Grease
2871515	U-Joint Grease (89 ml/3 oz. cartridge)
2871551	U-Joint Grease (414 ml cartridge)
2871329	Dielectric Grease (Nyogel™)
Additives / Miscellaneous	
2871326	Carbon Clean
2870652	Fuel Stabilizer
2872189	DOT 4 Brake Fluid
2871956	Loctite™ 565 Thread Sealant
2859044	POLARIS Battery Tender™ Charger
5253552	POLARIS Battery Strap Bracket for 30 AH Battery
4010630	POLARIS 30 AH Battery
2521372	POLARIS Air Filter

Drive Belt Wear/Burn

Possible Cause	Solution
Driving onto a pickup or tall trailer in high range	Use low range during loading.
Starting out going up a steep incline	Use low range. See warnings on page 42.
Driving at low RPM or ground speed (3-7 MPH)	Drive at a higher speed or use low range more frequently. See page 71.
Insufficient warm-up at low ambient temperatures	Warm the engine at least 5 minutes. With the transmission in neutral, advance the throttle to about 1/8 throttle in short bursts, 5 to 7 times. The belt will become more flexible and prevent belt burning.
Slow/easy clutch engagement	Use the throttle quickly and effectively.
Towing/pushing at low RPM/low ground speed	Use low range only.
Utility use/plowing	Use low range only.
Stuck in mud or snow	Shift the transmission to low range and carefully use fast, aggressive throttle application to engage clutch. WARNING: Excessive throttle may cause loss of control and vehicle roll-over.
Climbing over large objects from a stopped position	Shift the transmission to low range and carefully use fast, brief, aggressive throttle application to engage clutch. WARNING: Excessive throttle may cause loss of control and vehicle roll-over.
Belt slippage from water or snow ingestion into the PVT system	Dry out the PVT. See page 73. Inspect clutch seals for damage if repeated leaking occurs.
Clutch malfunction	See your POLARIS dealer.
Poor engine performance	Check for fouled plugs or foreign material in fuel tank or fuel lines. See your dealer.
Slippage from failure to warm up belt	Always warm up the belt by operating below 30 MPH for one mile (5 miles or more when temperature is below freezing).
Wrong or missing belt	Install the recommended belt.
Improper break-in	Always break in a new belt and/or clutch. See pages 37 and 71.

TROUBLESHOOTING

Engine Doesn't Turn Over

Possible Cause	Solution
Low battery voltage	Recharge the battery to 12.8 VDC
Loose battery connections	Check all connections and tighten
Loose solenoid connections	Check all connections and tighten
Loose electronic control box connections	Inspect, clean, reinstall connectors

Engine Turns Over, Fails to Start

Possible Cause	Solution
Out of fuel	Refuel
Clogged fuel filter	See your POLARIS dealer
Water is present in fuel	Drain the fuel system and refuel
Old or non-recommended fuel	Replace with fresh recommended fuel
Fouled or defective spark plug	Inspect plug and replace if necessary
No spark to spark plug	Inspect plug and replace if necessary
Water or fuel in crankcase	Immediately see your POLARIS dealer
Low battery voltage	Recharge the battery to 12.8 VDC
Mechanical failure	See your POLARIS dealer

Engine Backfires

Possible Cause	Solution
Weak spark from spark plug	Inspect, clean and/or replace spark plug
Incorrect spark plug gap or heat range	Set gap to specs or replace plug
Old or non-recommended fuel	Replace with fresh recommended fuel
Incorrectly installed spark plug wires	See your POLARIS dealer
Incorrect ignition timing	See your POLARIS dealer
Mechanical failure	See your POLARIS dealer
Loose ignition connections	Check all connections and tighten
Water present in fuel	Replace with fresh recommended fuel

Engine Pings or Knocks

Possible Cause	Solution
Poor quality or low octane fuel	Replace with recommended fuel
Incorrect ignition timing	See your POLARIS dealer
Incorrect spark plug gap or heat range	Set gap to specs or replace plug

TROUBLESHOOTING

Engine Runs Irregularly, Stalls or Misfires

Possible Cause	Solution
Fouled or defective spark plug	Inspect, clean and/or replace spark plug
Worn or defective spark plug wires	See your POLARIS dealer
Incorrect spark plug gap or heat range	Set gap to specs or replace plug
Loose ignition connections	Check all connections and tighten
Water present in fuel	Replace with new fuel
Low battery voltage	Recharge battery to 12.8 VDC
Kinked or plugged fuel tank vent line	Inspect and replace
Incorrect fuel	Replace with recommended fuel
Clogged air filter	Inspect and clean or replace
Low fuel pressure	See your POLARIS dealer
Other mechanical failure	See your POLARIS dealer
Possible Lean Fuel Cause	Solution
Low or contaminated fuel	Add or change fuel, clean the fuel system
Low octane fuel	Replace with recommended fuel
Clogged fuel filter	See your POLARIS dealer
Possible Rich Fuel Cause	Solution
Fuel is very high octane	Replace with lower octane fuel

Engine Stops or Loses Power

Possible Cause	Solution
Out of fuel	Refuel
Kinked or plugged fuel vent line	Inspect and replace
Water is present in fuel	Replace with new fuel
Fouled or defective spark plug	Inspect, clean and/or replace spark plug
Worn or defective spark plug wires	See your POLARIS dealer
Incorrect spark plug gap or heat range	Set gap to specs or replace plug
Loose ignition connections	Check all connections and tighten
Low battery voltage	Recharge the battery to 12.8 VDC
Incorrect fuel	Replace with fresh recommended fuel
Clogged air filter	Inspect and clean or replace
Other mechanical failure	See your POLARIS dealer
Overheated engine	Clean radiator screen and core, clean engine exterior, see your POLARIS dealer

WARRANTY

Limited Warranty

POLARIS Industries Inc., 2100 Highway 55, Medina, MN 55340 (POLARIS) gives a TWO YEAR LIMITED WARRANTY on all components of your POLARIS vehicle against defects in material or workmanship. POLARIS further warrants that the spark arrester in this product will meet the efficiency requirements of USFS standard 5100-1C for at least 1000 hours when subjected to normal use and when maintenance and installation are in accordance with POLARIS recommendations.

This warranty covers parts and labor charges for repair or replacement of defective parts and begins on the date of purchase by the original retail purchaser. This warranty is transferable to another owner during the warranty period through a POLARIS dealer, but any such transfer will not extend the original term of the warranty. The duration of this warranty may vary by international region based upon local laws and regulations.

Registration

At the time of sale, the Warranty Registration Form must be completed by your dealer and submitted to POLARIS within ten days of purchase. Upon receipt of this registration, POLARIS will record the registration for warranty. No verification of registration will be sent to the purchaser as the copy of the Warranty Registration Form will be your proof of warranty coverage. If you have not signed the original registration and received the customer copy, please contact your dealer immediately. **NO WARRANTY COVERAGE WILL BE ALLOWED UNLESS YOUR VEHICLE IS REGISTERED WITH POLARIS.** Initial dealer preparation and set-up of your vehicle is very important in ensuring trouble-free operation. Purchasing a machine in the crate or without proper dealer set-up will void your warranty coverage.

Warranty Coverage And Exclusions:

Limitations Of Warranties And Remedies

This POLARIS limited warranty excludes any failures that are not caused by a defect in material or workmanship. **THIS WARRANTY DOES NOT COVER CLAIMS OF DEFECTIVE DESIGN.** This warranty also does not cover acts of God, accidental damage, normal wear and tear, abuse or improper handling. This warranty also does not cover any vehicle, component, or part that has been altered structurally, modified, neglected, improperly maintained or used for racing, competition or purposes other than for which it was designed.

This warranty excludes damages or failures resulting from improper lubrication; improper engine timing; improper fuel; surface imperfections caused by external stress, heat, cold or contamination; operator error or abuse; improper component alignment, tension, adjustment or altitude compensation; snow, water, dirt or other foreign substance ingestion/contamination; improper maintenance; modified components; use of aftermarket or unapproved components, accessories, or attachments; unauthorized repairs; or repairs made after the warranty period expires or by an unauthorized repair center.

Warranty Coverage And Exclusions: Limitations Of Warranties And Remedies

This warranty excludes damages or failures caused by abuse, accident, fire, or any other cause other than a defect in materials or workmanship and provides no coverage for consumable components, general wear items, or any parts exposed to friction surfaces, stresses, environmental conditions and/or contamination for which they were not designed or not intended, including but not limited to the following items:

- Wheels and tires
- Suspension components
- Brake components
- Seat components
- Clutches and components
- Steering components
- Batteries
- Light bulbs/Sealed beam lamps
- Filters
- Lubricants
- Bushings
- Finished and unfinished surfaces
- Carburetor/Throttle body components
- Engine components
- Drive belts
- Hydraulic components and fluids
- Circuit breakers/Fuses
- Electronic components
- Spark plugs
- Sealants
- Coolants
- Bearings

Lubricants and Fluids

1. Mixing oil brands or using non-recommended oil may cause engine damage. We recommend the use of POLARIS engine oil.
2. Damage or failure resulting from the use of non-recommended lubricants or fluids is not covered by this warranty.

This warranty provides no coverage for personal loss or expense, including mileage, transportation costs, hotels, meals, shipping or handling fees, product pick-up or delivery, replacement rentals, loss of product use, loss of profits, or loss of vacation or personal time.

THE EXCLUSIVE REMEDY FOR BREACH OF THIS WARRANTY SHALL BE, AT POLARIS' OPTION, REPAIR OR REPLACEMENT OF ANY DEFECTIVE MATERIALS, COMPONENTS, OR PRODUCTS. THE REMEDIES SET FORTH IN THIS WARRANTY ARE THE ONLY REMEDIES AVAILABLE TO ANY PERSON FOR BREACH OF THIS WARRANTY. POLARIS SHALL HAVE NO LIABILITY TO ANY PERSON FOR INCIDENTAL, CONSEQUENTIAL OR SPECIAL DAMAGES OF ANY DESCRIPTION, WHETHER ARISING OUT OF EXPRESS OR IMPLIED WARRANTY OR ANY OTHER CONTRACT, NEGLIGENCE, OR OTHER TORT OR OTHERWISE. THIS EXCLUSION OF CONSEQUENTIAL, INCIDENTAL, AND SPECIAL DAMAGES IS INDEPENDENT FROM AND SHALL SURVIVE ANY FINDING THAT THE EXCLUSIVE REMEDY FAILED OF ITS ESSENTIAL PURPOSE.

THE IMPLIED WARRANTY OF FITNESS FOR A PARTICULAR PURPOSE IS EXCLUDED FROM THIS LIMITED WARRANTY. ALL OTHER IMPLIED WARRANTIES (INCLUDING BUT NOT LIMITED TO THE IMPLIED WARRANTY OF MERCHANTABILITY) ARE LIMITED IN DURATION TO THE ABOVE TWO YEAR WARRANTY PERIOD. POLARIS DISCLAIMS ALL EXPRESS WARRANTIES NOT STATED IN THIS WARRANTY. SOME STATES DO NOT PERMIT THE EXCLUSION OR LIMITATION OF INCIDENTAL OR CONSEQUENTIAL DAMAGES OR ALLOW LIMITATIONS ON THE DURATION OF IMPLIED WARRANTIES, SO THE ABOVE LIMITATIONS MAY NOT APPLY TO YOU IF INCONSISTENT WITH CONTROLLING STATE LAW.

WARRANTY

How To Obtain Warranty Service

If your vehicle requires warranty service, you must take it to a POLARIS Servicing Dealer. When requesting warranty service you must present your copy of the Warranty Registration Form to the dealer. (THE COST OF TRANSPORTATION TO AND FROM THE DEALER IS YOUR RESPONSIBILITY.) POLARIS suggests that you use your original selling dealer; however, you may use any POLARIS Servicing Dealer to perform warranty service.

In the Country where your product was purchased:

Warranty or Service Bulletin repairs must be done by an authorized POLARIS dealer. If you move or are traveling within the country where your product was purchased, Warranty and Service Bulletin repairs may be requested from any authorized POLARIS dealer that sells the same line as your product.

Outside the Country where your product was purchased:

If you are traveling temporarily outside the country where your product was purchased, you should take your product to an authorized POLARIS dealer. You must show the dealer photo identification from the country of the selling dealer's authorized location as proof of residence. Upon residence verification, the servicing dealer will be authorized to perform the warranty repair.

If you move:

If you move to another country, be sure to contact POLARIS Customer Assistance and the customs department of the destination country before you move. Product importation rules vary considerably from country to country. You may be required to present documentation of your move to POLARIS in order to continue your warranty coverage. You may also be required to obtain documentation from POLARIS in order to register your product in your new country. You should warranty register your product at a local POLARIS dealer in your new country immediately after you move to continue your warranty coverage and to ensure that you receive information and notices regarding your vehicle.

If you purchase from a private party:

If you purchase a POLARIS product from a private party, to be kept and used outside of the country in which the product was originally purchased, all warranty coverage will be denied. You must nonetheless register your product under your name and address with a local POLARIS dealer in your country to ensure that you receive safety information and notices regarding your product.

Exported Products

EXCEPT WHERE SPECIFICALLY REQUIRED BY LAW, THERE IS NO WARRANTY OR SERVICE BULLETIN COVERAGE ON THIS PRODUCT IF IT IS SOLD OUTSIDE THE COUNTRY OF THE SELLING DEALER'S AUTHORIZED LOCATION. This policy does not apply to products that have received authorization for export from POLARIS. Dealers may not give authorization for export. You should consult an authorized dealer to determine this product's warranty or service coverage if you have any questions. This policy does not apply to products registered to government officials or military personnel on assignment outside the country of the selling dealer's authorized location. This policy does not apply to Safety Bulletins.

Notice

If your product is registered outside of the country where it was purchased and you have not followed the procedure set above, your product will no longer be eligible for warranty or service bulletin coverage of any kind, other than safety bulletins. Products registered to government officials or military personnel on assignment outside of the country where the product was purchased will continue to be covered by the Limited Warranty.

Please work with your dealer to resolve any warranty issues. Should your dealer require any additional assistance, they will contact the appropriate person at POLARIS.

This warranty gives you specific legal rights, and you may also have other rights which vary from state to state or in different countries. If any of the above terms are void because of federal, state, local law, all other warranty terms will remain in effect.

INDEX

A		D	
Accessory Outlets	22	Declaration of Conformity	5
Adjustment		Disengaging AWD	50
Shock Spring	77	Display Units, Standard/Metric	34
Air Filter	74	Drive Belt Wear	93
Air Filter Cleaning	74	Drive Mode Operation, AWD	49
All Wheel Drive	49-51	Drivetrain Break-In	37
Disengaging AWD	50	Driving Downhill	42
Engaging AWD	50	Driving in Reverse	43
Auxiliary Outlets	22	Driving on a Sidehill	43
AWD Drive Mode Switch	25, 49	Driving on Slippery Surfaces	41
Axle Nut Torque	78	Driving Over Obstacles	41
		Driving Procedure	40
		Driving Through Water	44
		Driving Uphill	42
		Driving with a Passenger	40
		Driving, After Driving in Water	73
		Drying the Transmission	73
		Dumping the Cargo Box	48
B		E	
Battery	82-85	Electronic Power Steering	27
Charging (Conventional)	85	Engaging AWD	50
Charging (Sealed)	85	Engine Break-In	37
Extreme Use 30 AH	28	Engine Fogging	88
Fluid (Conventional)	82	Engine Oil (570)	64-65
Installation	84	Engine Starting	39
Removal	83	Engine Stopping	39
Storage	84	EPS	27
Warnings	82	Equipment Modifications	15
Belt Burning	93	Error Codes, Engine	36
Belt Life	47	Exhaust Cleaning	75
Belt Replacement	71-72	Exhaust Emission Control System	60
Belt Wear	93	Exhaust System Warning	75
Brake Fluid	76	Extreme Use 30 AH Battery	28
Brake Inspection	76	Eye Protection	9
Brake Lever, Park	26		
Brake Light	81	F	
Brake Lights	81	Filter Cleaning, Air	74
Brake Pedal	26	Filter, Air	74
Brakes	76	Fluid	
Braking	39	Battery Fluid	82
Break-In Period	37	Fluid Change	
		Front Gearcase	67
		Main Gearcase	66
		Transmission	66
		Fluid Check	
		Coolant (Overflow Bottle)	70
		Front Gearcase	67
		Main Gearcase	66
		Transmission	66
		Fluid Levels During Storage	88
		Fluid Recommendation	
		Gearcases	66
		Fluid Recommendations	
		Gearcase Fluid	63
		Fluid, Brake	76
		Fogging the Engine	88
		Fouled Plugs	68
		Front Gearcase	67
		Fuel Cap	27
		Fuel Safety	20
		Fuel Stabilizer	87
		Fuel Tank Filler Cap	27
		Fuses	80
C			
Cab Frame, ROPS	31		
Cab Nets	30		
Cargo	46		
Cargo Box, Dumping	48		
Chart, Periodic Maintenance	61-63		
Check Engine Indicator	36		
Chrome Wheel Care	87		
Cleaning and Storage	86-88		
Cleaning the Air Filter	74		
Cleaning the Exhaust System	75		
Cleaning the Spark Arrestor	75		
Clutching	91		
Console	22-23		
Coolant Level, Overflow Bottle	70		
Coolant, Adding or Changing	69		
Cooling Fan	69		
Cooling System	69-70		
Corrosion Removal, Chrome	87		

G	
Gap, Spark Plug	68
Gasoline Handling	20
Gear Selector	23
Gearcase Specification Chart	66
Gearcase, Front	67
Gearcase, Main	66
Gearcases	67
Gears, Shifting	23

H	
Hauling Cargo	46
Hazard Switch	24
Headlight Beam Adjustment	81
Headlight Lamp Replacement	80
Helmet	8
High Beam Switch	24
Hitch Bracket	31
Hitch Weight	47
Horn Switch	24

I	
Ignition Switch	24
Immersion of Vehicle	73
Indicator Lamps	32
Instrument Cluster	32-36

K	
Key, Periodic Maintenance Chart	61

L	
Light Switch	24
Lights	81
Brake Lights	81
Headlight Beam Adjustment	81
Headlight Lamp Replacement	80
Taillight/Brake Light/Signal Lamp	81
Lubricants, Gearcase	66
Lubrication Recommendations	63

M	
Main Gearcase	66
Maintenance Log	99
Maintenance, Periodic	61-63
Metric Display	34
Mirrors	27
Mode Button	24
Modifications	15

N	
Noise Emission Control System	60

O	
Obstacles	41
Oil	
Engine (570)	64-65
Oil Change	
Engine Oil (570)	64-65
Front Gearcase	67
Main Gearcase	66
Transmission	66
Oil Check	
Engine Oil (570)	64
Front Gearcase	67
Main Gearcase	66
Transmission	66
Oil Recommendation	
Gearcases	66
Operator Safety	13-20
Outlets, Auxiliary	22

P	
Park Brake Lever	26
Parking on an Incline	45
Parking the Vehicle	45
Periodic Maintenance Chart	61-63
Plug Gap	68
Plug Torque	68
Plug, Accessory	22
Plugs, Fouled	68
Polaris Products	92
Polishing the Vehicle	86
Power Steering	27
Power Steering Unit (Cleaning)	79
Pre-Ride Inspection	38
PVT Break-In	37
PVT Drying	73
PVT System	72-73
PVT System Operation	71
PVT Warning	71-73
PVT, Cleaning Debris	71-72

R	
Radiator	69
Registration, Warranty	96
Removing the Vehicle from Storage	89
Reverse Operation	43
Rider Information Center	33-36
Riding Gear	8-9
Rollover Protective Structure	31
ROPS Cab Frame	31

INDEX

S

Safety Labels	10, 12
Safety Symbols	4
Safety Training	7
Safety, Winch Maintenance	59
Seat Belt Inspection	29
Seat Belts	29
Seat Removal	27
Severe Use Definition	61
Shifter	23
Shifting Gears	23
Shock Loading the Winch	58
Shock Spring Adjustment	77
Signal Words	4
Spark Arrester	60
Spark Arrester Warning	75
Spark Arrester, Cleaning	75
Spark Plug Gap	68
Spark Plug Inspection	68
Spark Plug Recommendations	68
Spark Plug Torque	68
Spark Plugs	68
Spark Plugs, Fouled	68
Specifications	90-91
Specifications, Gearcase	66
Speed, Towing	47
Speedometer	32
Starting the Engine	39
Steering Lock	28
Steering Wheel Inspection	77
Steering Wheel, Adjustment	22
Stopping the Engine	39
Storage	86-88
Storage Area	88
Storage Tips	87
Storage, Battery	84
Storage, Covers	88
Storage, Removal from	89
Switches	24-25
AWD Drive Mode Switch	25, 49
Hazard Switch	24
High Beam Switch	24
Horn Switch	24
Ignition Switch	24
Light Switch	24
Turn Signal Lever	25

T

Tachometer	35
Taillight	81
Throttle Pedal	26
Tilt Steering	22
Tires	78-79
Nut Torque	78
Tread Depth	78
Wheel Installation	79
Wheel Removal	79
Torque, Spark Plug	68
Towing a RANGER	47
Towing Loads	47
Towing Speed	47
Trailer Hitch Bracket	31
Training	7
Transmission	66
Transmission Operation	71-73
Transmission System	72-73
Transmission Warning	71-73
Transmission, Drying	73
Transporting the Vehicle	89
Turn Signal Lamp	81
Turn Signal Lever	25

V

Vehicle Components	21
Vehicle Identification Numbers	6
Vehicle Immersion	73
Vehicle Transport	89

W

Warning Symbols	4
Warning, Transmission Modification	71-73
Washing the Vehicle	86
Wheel Installation	79
Wheel Nut Torque	78
Wheel Removal	79
Winch Cable Care	57
Winch Maintenance and Service Safety	59
Winch Operation	54-57
Winch Safety Precautions	52-53
Winch Shock Loading	58



POLARIS®

For your nearest Polaris dealer,
visit www.polaris.com

Polaris Sales Europe Sarl
Route de l'Etraz
Business Center A5
1180 Rolle, Switzerland

Part No. 9927385 Rev 01

