

BRIDGESTONE

OWNER'S HANDBOOK & SERVICE MANUAL

50 Sport, 60 Sport, 90, 90 Trail,
90 Mountain, 90 Sport, 175 Dual Twin

from Fourth Printing June, 1974

Originally Published by

CLYMER PUBLICATIONS

*World's largest publisher of books devoted exclusively to
automobiles and motorcycles.*

222 NORTH VIRGIL AVENUE, LOS ANGELES, CALIFORNIA 90004

TECHNICAL HANDBOOK

Index

SPECIFICATIONS	<u>1</u>	TO CHECK TIMING - RIGHT CYLINDER	<u>57</u>
BS 50 Sport	<u>1</u>	RIGHT CYLINDER TIMING ADJUSTMENT	<u>58</u>
BS 60 Sport	<u>1</u>	TO CHECK TIMING-LEFT CYLINDER	<u>58</u>
90 cc	<u>3</u>	LEFT CYLINDER TIMING ADJUSTMENT	<u>58</u>
175 Dual Twin	<u>5</u>	B. Ignition Coils	<u>58</u>
I. ENGINE DISASSEMBLY & REASSEMBLY	<u>7</u>	C. Technical Standards	<u>59</u>
50 Sport, 60 Sport and 90cc models	<u>7</u>	D. Generator	<u>59</u>
II. REASSEMBLY	<u>12</u>	E. Selenium Rectifier	<u>60</u>
175 DT	<u>15</u>	F. Battery	<u>60</u>
II. ENGINE DISASSEMBLY	<u>16</u>	G. Headlight	<u>60</u>
III. ENGINE REASSEMBLY	<u>19</u>	H. Spark plugs	<u>60</u>
IV. INSTALLING ENGINE INTO FRAME	<u>24</u>	Dry Charged Storage Batteries	<u>61</u>
CYLINDERS AND PISTONS	<u>26</u>	FRONT FORK	<u>63</u>
A. Construction and Operation:	<u>26</u>	Operation	<u>63</u>
CRANKSHAFT AND ROTARY DISC VALVES	<u>27</u>	Maintenance	<u>63</u>
A. Construction and Operation	<u>27</u>	Assembling Front Fork	<u>63</u>
B. Rotary Valve Modification	<u>28</u>	REAR SUSPENSION	<u>64</u>
50-60 SPORT, 90 & 90 SPORT	<u>28</u>	FRONT WHEEL	<u>65</u>
175 DUAL TWIN	<u>29</u>	Removing Front Wheel	<u>65</u>
KICK STARTER MECHANISM	<u>29</u>	Adjusting Front Brake	<u>65</u>
Construction and Operation	<u>29</u>	REAR WHEEL	<u>66</u>
CLUTCH	<u>31</u>	Removing Rear Wheel	<u>66</u>
A. Construction	<u>31</u>	Adjusting Rear Brake	<u>67</u>
B. Operation	<u>32</u>	PRE-DELIVERY SERVICE	<u>68</u>
C. Adjustment	<u>32</u>	B/S 90 w/Oil Injection	<u>68</u>
TRANSMISSION	<u>34</u>	175 DT	<u>69</u>
A. Construction and Operation	<u>34</u>	TROUBLESHOOTING: ENGINE	<u>71</u>
B. Gear Shift Mechanism	<u>35</u>	I. PRELIMINARY CHECK	<u>71</u>
C. Gear Shift Operation	<u>37</u>	II. SPARK PLUG	<u>71</u>
D. Gear Ratios	<u>41</u>	III. ENGINE OVERHEATING	<u>74</u>
CARBURETOR	<u>42</u>	TROUBLESHOOTING: TRANSMISSION	<u>75</u>
A. Construction and Operation	<u>42</u>	I. MISSED GEARS	<u>75</u>
B. Functions of Various Parts	<u>44</u>	TROUBLESHOOTING: ELECTRICAL	<u>76</u>
C. Adjustment	<u>45</u>	50, 60 Spt; 90cc	<u>76</u>
TO ADJUST FLOAT LEVEL:	<u>46</u>	I. KEY SWITCH	<u>76</u>
OIL INJECTION SYSTEM – 90cc	<u>47</u>	II. CHARGING SYSTEM	<u>76</u>
A. Construction and Operation	<u>47</u>	III. BRAKE LIGHT SWITCH	<u>76</u>
B. Adjustment	<u>48</u>	IV. HEAD LIGHT	<u>77</u>
C. Special Attention to the Oil Injection System	<u>49</u>	V. HORN CIRCUIT	<u>77</u>
OIL INJECTION SYSTEM – 175DT	<u>50</u>	VI. SELENIUM RECTIFIER	<u>77</u>
A. Construction and Operation	<u>50</u>	175 DT	<u>77</u>
B. Adjustment	<u>51</u>	ALL MODELS	<u>78</u>
C. Special Attention — Pump Modification	<u>52</u>	INSPECTION AND MAINTENANCE	<u>79</u>
ELECTRICAL EQUIPMENT – 50, 60 Sport, 90cc	<u>53</u>	SERVICE STANDARDS	<u>80</u>
A. Ignition System	<u>53</u>	APPENDIX	<u>81</u>
Contact Breaker	<u>53</u>	USEFUL FORMULAS AND TABLES	<u>81</u>
Ignition Timing	<u>53</u>	CONVERSIONS	<u>82</u>
TO SET TIMING	<u>53</u>	EXAMPLES OF CONVERSIONS	<u>83</u>
Condenser	<u>54</u>	TEMPERATURE	<u>83</u>
Spark Plug	<u>54</u>	PISTON DISPLACEMENT	<u>83</u>
B. Testing the Ignition Coil	<u>55</u>	COMPRESSION RATIO	<u>84</u>
C. Technical Standards	<u>55</u>	HORSEPOWER AND TORQUE	<u>85</u>
D. Lighting System	<u>55</u>	PISTON SPEED	<u>85</u>
E. Testing the Lighting Coil	<u>56</u>	GEAR RATIO	<u>86</u>
F. Selenium Rectifier	<u>56</u>	BOLT TORQUE	<u>87</u>
G. Battery Charging (50-60 Spt)	<u>56</u>		
ELECTRICAL EQUIPMENT – 175 DT	<u>57</u>		
Contact Breakers	<u>57</u>		
Ignition timing	<u>57</u>		

SPECIFICATIONS

	BS 50 Sport	BS 60 Sport
'Engine:		
(1) Type:	2-stroke, Single Cyl.	2-stroke, Single Cyl.
(2) Piston Displacement:	50cc.(3.15cu.in.)	58cc.(3.54cu.in.)
(3) Bore & Stroke	39 mm x 42 mm (1.53 x 1.65 in.)	42 mm x 42 mm (1.65 x 1.65)
(4) Compression Ratio:	6.60:1	6.70:1
(5) Max. Brake H.P.	5.2 HP/8500 rpm.	5.6 HP/8500 rpm.
(6) Max. Torque:	0.45 kg-m/7500 rpm.	0.48 kg-m/7500 rpm.
(7) Air Intake System:	Rotary Disc Valve	Rotary Disc Valve
(8) Starting System:	Kick Starter	Kick Starter
(9) Charging System:	A.C. Magneto	A.C. Magneto
(10) Ignition System:	Flywheel Magneto	Flywheel Magneto
(11) Ignition Timing:	19° before T.D.C.	19° before T.D.C.
(12) Spark Plug:	N.G.K. B-7	N.G.K.. B-8
(13) Carburetor:	AMAL Type, VW15SC.	AMAL Type, VW15SC.
(14) Fuel Mixture:	20 to 1 (gasoline) (motor oil SAE No. 30)	20 to 1 (gasoline) (motor oil SAE No. 30)
(15) Transmission Oil:	0.132 gal. in trans. case; SAE #20 (winter) or SAE 10W30 (all season)	0.132 gal. in trans. case; SAE #20 (winter) or SAE 10W30 (all season)
* Performance:		
(1) Max. Speed:	85 km/h (53 mph)	88 km/h (55 mph)
(2) Climbing Ability:	1 in 3.5	1 in 3.5
(3) Fuel Consumption:	200mpg/20mph at 30km/h paved level test road	176mpg/20mph at 30km/h paved level test road
(4) Min. Turning Radius:	1.8m (70.8 inch)	1.8m (70.8 inch)
(5) Acceleration:	14.5 sec. (Stan. st. 0-200 m)	14.0 sec. (Stan. st. 0-200 m)
(6) Braking Distance:	Less than 8 m at 35 km/h (26 feet, at 22 mph)	Less than 8 m at 35 km/h (26 feet, at 22 mph)
'Frame & Suspension:		
(1) Frame Type:	Pressed Steel/Backbone	Pressed Steel/Backbone
(2) Front Suspension:	Telescopic Fork with Hydraulic Damper	Telescopic Fork with Hydraulic Damper,

Transmission

(1) Clutch:	Manual, Multi. disc in oil	Manual, Multi. disc in oil
(2) Transmission:	4 speed constant mesh gear & foot control	4 speed constant mesh gear & foot control
(3) Gear Ratio:	Primary (Hel. gr.) 1 : 4.05 Gear Box: 1st: 1 : 2.92 2nd: 1 : 1.83 3rd: 1:1.32 4th: 1 : 1.00 Secondary (Chain): 1 : 2.77 Total Gear Ratio: 1st: 1 : 32.8 2nd: 1 : 20.5 3rd: 1 : 14.8 4th: 1 : 11.2	1 : 4.05 1 : 2.92 1 : 1.83 1 : 1.32 1 : 1.00 1 : 2.54 1 : 30.0 1 : 18.8 1 : 13.6 1 : 10.3

•Dimensions, Weight:

(1) Overall Length:	1,810 mm (71.3 in.)	1,810 mm (71.3 in.)
(2) Overall Width:	660 mm (26.0 in.)	660 mm (26.0 in.)
(3) Overall Height:	970 mm (38.1 in.)	970 mm (38.1 in.)
(4) Saddle Height:	750 mm (29.5 in.)	750 mm (29.5 in.)
(5) Wheelbase:	1,160 mm (45.7 in.)	1,160 mm (45.7 in.)
(6) Road Clearance:	130 mm (5.10 in.)	130 mm (5.10 in.)
(7) Tire Size (Front):	2.25-17, 4 ply	2.25-17, 4 ply
(Rear):	2.25-17, 4 ply	2.25-17, 4 ply
(8) Tire Pressure (Front):	22.8 lbs/in ²	22.8 lbs/in ²
(Rear):	28.4 lbs/in ²	28.4 lbs/in ²
(9) Caster:	63	63
(10) Trail:	78 mm (3.07 inch)	78 mm (3.07 inch)
(11) Banking Angle:	45 degrees	45 degrees
(12) Net Weight:	69 kg (152 lbs)	69 kg (152 lbs)
(13) Fuel Tank Capacity:	1.72 gal. including 0.264 gal. reserve	1.72 gal. including 0.264 gal. reserve
(14) Front Brake:	Right Hand	Right Hand
(15) Rear Brake:	Right Foot	Right Foot

'Electrical Equipment:

(1) Head light:	6V-15/15W	6V-15/15W
(2) Tail light:	6V-2W 6V-5W (exclusively C.H.P.) 6V-18W (exclusively C.H.P.)	6V-2W 6V-5W 6V-18W
(3) Stop light:	6V-8W	6V-8W
(4) Battery:	6V-2AH	6V-2AH

SPECIFICATIONS

90 cc

*Engine:

(1) Type:	2-stroke. Single Cylinder
(2) Piston Displacement:	88 c.c. (5.39 cu-inch)
(3) Bore & Stroke:	50 mm x 45 mm (1.97 x 1.77 inch)
(4) Compression Ratio:	6.8 : 1
(5) Max. Brake H.P.	7.8 HP/7000 rpm. (8.8 HP/8000 - 90 Spt)
(6) Max. Torque:	0.85 kg-m/5000 rpm
(7) Air Intake System:	Rotary disc valve
(8) Starting System:	Kick Starter
(9) Charging System:	A.C. Magneto
(10) Ignition System:	Flywheel Magneto
(11) Ignition Timing:	21 degrees before T.D.C.
(12) Spark Plug:	N.G.K. B-7H
(13) Carburetor:	AMAL Type, VM 15SC (VM 17SC-90 Spt)
(14) Fuel Mixture:	Gasoline
(15) Transmission Oil:	0.6 litre (0.158 US gal.) in transmission SAE #30 (summer); SAE #20 (winter) SAE #10W30 in all seasons

*Performance:

(1) Max. Speed:	95km/h(60mph) (105 kh/h—65 mph—90 Spt)
(2) Climbing Gradient:	1 in 3
(3) Fuel Consumption:	75 km/L (177 mpg/20 mph) at 30 km/h on paved flat test road
(4) Min. Turning Radius:	1.8 m (70.8 inch)
(5) Acceleration:	13.0 seconds (0-200 m) (12.0Sec—90 Spt)
(6) Braking Distance:	6 m at 35 km/h (20 feet, at 22 mph)

* Frame Suspension:

(1) Frame Type:	Pressed Steel, Backbone Type
(2) Front Suspension:	Telescopic Fork with Hydraulic Damper
(3) Rear Suspension:	Swinging Arm with Hydraulic Damper

•Transmission

- (1) Clutch: Manual, Multiple discs in oil bath
- (2) Transmission: 4 speed constant-mesh gear & foot control
- (3) Gear Ratio: Primary (Helical Gear): 1 : 3.95
 - 1st: 1: 2.77
 - 2nd: 1: 1.72
 - 3rd: 1: 1.23
 - 4th: 1: 0.924Secondary (Chain): 1 : 2.43
Total Gear Ratio: 1st: 1 : 26.58
 - 2nd: 1: 16.51
 - 3rd: 1: 11.81
 - 4th: 1: 8.86

'Dimensions & Weight:

- (1) Overall Length: 1,830 mm (72.0 inch)
- (2) Overall Width: with Standard Handle Bar 660 mm (26.0 inch)
with Flat Bar 580 mm (22.8 inch)
- (3) Overall Height: 970 mm (38.1 inch)
- (4) Saddle Height: 750 mm (29.5 inch) (30.1 inch—90 Spt)
- (5) Wheel base: 1,160 mm (45.7 inch)
- (6) Road Clearance: 150 mm (5.9 inch)
- (7) Tire Size (Front): 2.50-17, 4 ply
(Rear): 2.50-17, 4 ply
- (8) Tire Pressure: (Front): 1.6kg/cm(22.8 lbs/in) (Same—90 Spt)
(Rear): 2.4 kg/cm (34.2 lbs/in) (28.4 lbs/in—90 Spt)
- (9) Caster: 63 degrees
- (10) Trail: 80 mm (3.15 inch)
- (11) Banking Angle: 45 degrees (47 degrees – 90 Spt)
- (12) Net Weight: 79kg(1741bs)
- (13) Fuel Tank Capacity: 7.0 L (1.85 US gal) (2.25 US gal—90 Spt)
including 0.264 gal. reserve (0.396 gal—90 Spt)
- (14) Front Brake: Right Hand
- (15) Rear Brake: Right Foot

***Electrical Equipment:**

- (1) Head light: 6V-15/15W
- (2) Tail light: 6V-2W
- (3) Stop light: 6V-8W
- (4) Turn signal light: 6V-8W
- (5) Battery: 6V-4AH

SPECIFICATIONS 175 Dual Twin

*Engine

- | | |
|----------------------------|--|
| (1) Type : | 2-stroke, Dual Cylinders |
| (2) Piston Displacement: | 177 cc. (10.8 cu-inch) |
| (3) Bore & Stroke: | 50 mm × 45 mm (1.97 × 1.77 inch) |
| (4) Compression Ratio: | 9.5: 1 |
| (5) Max. Brake Horsepower: | 20HP/8,000 rpm |
| (6) Max. Torque : | 1.9 kg-m/7, 500 rpm |
| (7) Air Intake System : | Rotary disc valve |
| (8) Starting System : | Kick Starter |
| (9) Charging System : | A. C. Generator |
| (10) Ignition System : | Battery |
| (11) Ignition Timing: | (21 +1,-2) degrees before T.D.C. |
| (12) Spark Plugs : | N G K B-8 H |
| (13) Carburetors : | AMAL Type. VM 17 SC |
| (14) Engine Lubrication : | 2 cycle engine motor oil |
| (15) Fuel: | Gasoline |
| (16) Transmission oil : | 0.8 litre (0.21 US gal.) in transmission case
SAE No. 10W/30 in all seasons or
SAE No. 30 in summer and SAE No. 20 in winter |

*Performance

- | | |
|---------------------------|--|
| (1) Max. Speed: | Over 130km/h(80 mph) |
| (2) Climbing Gradient: | 1 in 3 |
| (3) Fuel Consumption: | 55 km/l (129 mpg) at 40 km/h (25 mph) on paved flat test road. |
| (4) Min. Turning Radius : | 1.95 m (76. 8 inch) |
| (5) Acceleration: | |
| (Standing Start 1/4 mile) | Under 18 sec (0-400 m) |
| (6) Braking Distance : | Less than 6 m at 35 km/h (20 feet, at 22 mph). |

*Frame & Suspension

- | | |
|------------------------|---------------------------------------|
| (1) Frame Type : | Pipe Frame, Cradle Type |
| (2) Front Suspension : | Telescopic Fork with Hydraulic Damper |
| (3) Rear Suspension : | Swinging Arm with Hydraulic Damper |

***Transmission**

(1) Clutch :	Manual, Multiple discs in oil bath.
(2) Transmission :	Dual Transmission, selective 4-speed constant mesh-rotary or 5-speed constant mesh-return by shifting "sportshift" lever
(3) Gear Ratios:	Primary (Helical gear) : 1:3.41
	Gear Box: 1st 1:2.61
	2nd 1:1.67
	3rd 1:1.24
	4th 1:1.00
	5th 1: 0.85
	Secondary (Chain): 1: 2.37
	Total Gear Ratio : 1st 1:21.19
	2nd 1:13.50
	3rd 1:10.03
	4th 1: 8.10
	5th 1:6.86

***Dimensions and Weight**

(1) Overall Length:	1,885 mm (74.2 inch)
(2) Overall Width :	750 mm (29.5 inch)
	with Standard Western type Handlebar
(3) Overall Height:	1,020 mm (40.2 inch)
(4) Saddle Height :	780 mm (30.7 inch)
(5) Wheelbase:	1,235mm (48. 6 inch)
(6) Road Clearance :	150 mm (5.9 inch)
(7) Tire Size	(Front): 2.50-18 4 ply
	(Rear) : 2.75-18 4 ply
(8) Tire Pressure	(Front): 1.6kg/cm ² (221bs/in ²)
	(Rear) : 2.0 kg/cm ² (23 lbs/in ²)
(9) Caster :	64°
(10) Trail :	83.5 mm (3.29 inch)
(11) Banking Angle :	45°
(12) Net Weight :	123 kg (271 lbs)
(13) Fuel Tank Capacity:	10 L (2.64 US gal.)
	Including 1.2 litre (0.317 US gal.) reserve
(14) Oil Tank Capacity :	1.8 L (3.8 pint)
(15) Front Brake :	Right Hand Operated
(16) Rear Brake :	Right Foot Operated

***Electrical Equipment**

(1) Head light :	12 V - 35/25 W
(2) Tail light:	12V-8W
(3) Stop light:	12V-25W
(4) Speedometer lamp:	12V-3W
(5) Third gear indicator lamp:	12V-2W
(6) Neutral indicator lamp:	12V-2W
(7) Battery:	12V-6AH

I. ENGINE DISASSEMBLY & REASSEMBLY

50 Sport, 60 Sport and 90cc models

Most service can be performed on the engine without removing the engine from the frame. In fact, all operations which occur before the actual splitting of the crankcase sections can be accomplished with the engine mounted in the cycle frame. For complete engine disassembly, it is necessary to remove the engine from the frame. This sequence describes the dismantling of the engine from the frame, the complete disassembly of the engine, and engine reassembly.

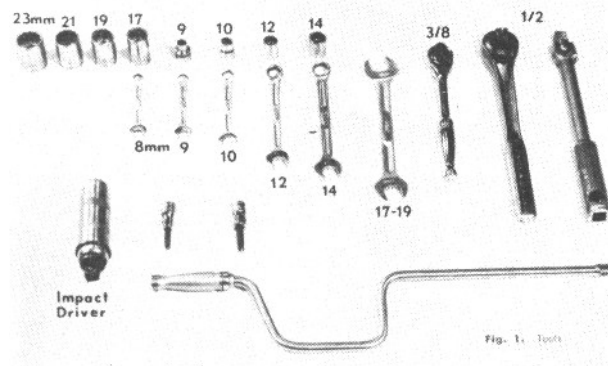

1. Remove the drain plug from the under side of the transmission case and completely drain the crankcase. Replace the drain plug.
2. Turn the fuel cock selector lever to the "O" position to shut off the fuel between the tank and the carburetor.
3. Raise the rubber carburetor cap.
4. Remove the carburetor cover from the side of the transmission case by removing the phillips head attaching screws.

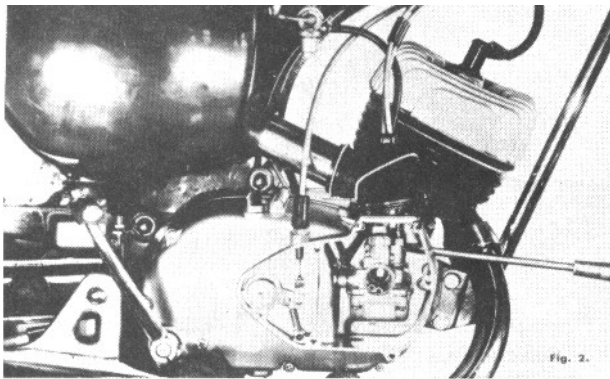

5. Remove the rubber plug from the access port in front of the carburetor enclosure.

6. Insert a screw driver through the access aperture and loosen the carburetor mounting bolt. (Fig. 2)
7. Disconnect the fuel line from the fuel cock.
8. Remove the carburetor from the carburetor adapter and allow it to hang suspended from the throttle cable and starter jet cable.

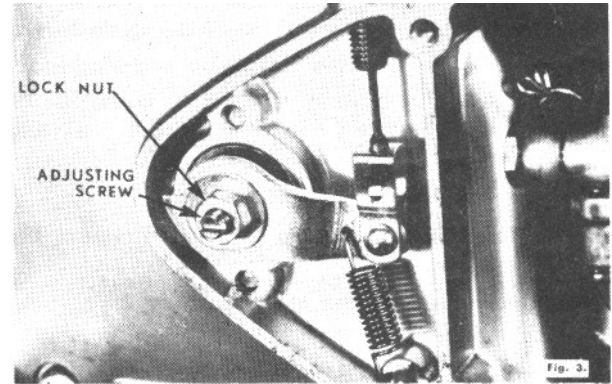

9. Remove the clutch release arm lock nut and washer and remove the clutch release arm from the release screw. (Fig. 3)
10. Disconnect the clutch cable from the clutch release arm.

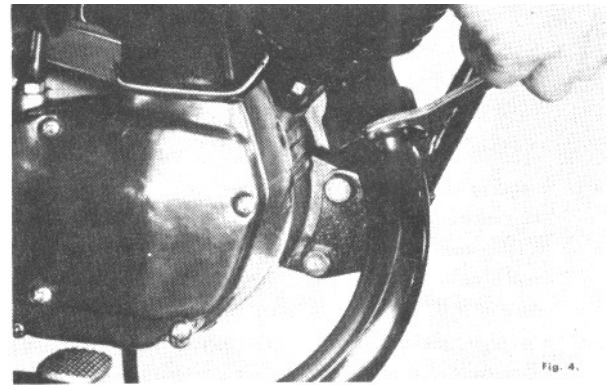

11. Unscrew the clutch cable adjusting screw completely out of the threaded boss on top of the carburetor enclosure.
12. Pull the clutch cable free of the carburetor enclosure.
13. Using the special exhaust pipe clamp nut wrench, (Fig. 4) loosen the exhaust pipe clamp nut and rotate the exhaust pipe toward you down and out of the way.
14. Remove the two bolts which connect the engine hanger to the front of the engine.

Loosen the bolt at the top of the engine hanger and swing the engine hanger forward.

15. Moving to the left hand side of the machine, remove the gear shift lever.
16. Remove the magneto cover retaining screws.
17. Remove the two hex head bolts from the lower half of the chain case and remove the lower chain case section.
18. Remove the left hand battery cover.
Disconnect the wires running from the magneto to the battery. Remove the battery band and remove the battery. Locate the chain connecting link and chain connector. Dismount the drive chain from the small sprocket. Temporarily reconnect the chain to avoid losing the chain connector. Pull the magneto wire loom out of the cycle frame.
19. Remove the nuts from the engine mounting bolts. The nuts are located on the right hand side of the machine. Withdraw the engine mounting bolts from the left hand side of the machine.
20. Lower the engine out of the frame.

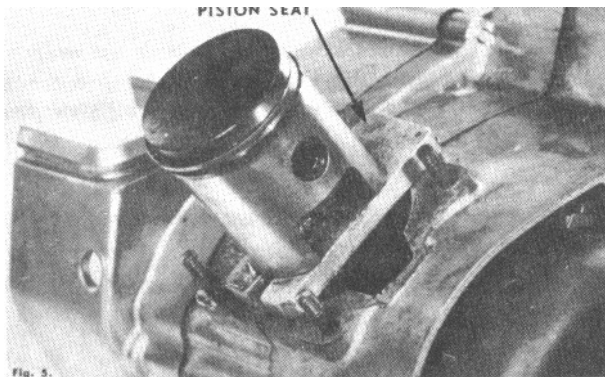

21. Place the engine on the bench and remove the kick starter lever.
22. Remove the cylinder head mounting bolts using a 10mm socket wrench.
23. Using a 10mm open end wrench, remove the four cylinder mounting nuts. Lift the cylinder off the cylinder mounting studs.

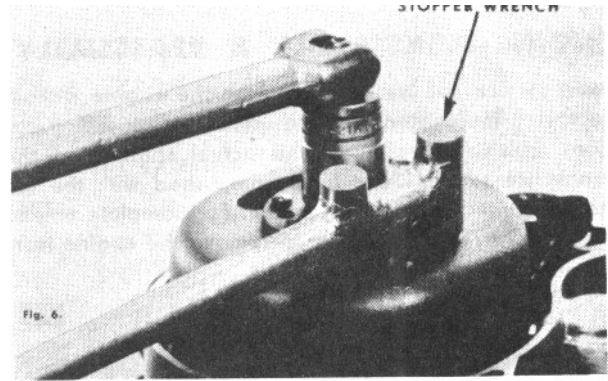

24. As soon as the cylinder is removed, insert the piston seat (special tool) under the piston. This special tool protects the piston during disassembly and it also holds the crankshaft stationary for further disassembly operation. (Fig. 5)
25. Remove the piston pin snap rings and remove the piston pin and piston from the connecting rod. A suitable piston pin puller must be used in this operation. This is provided in the Bridgestone special tool kit.
26. Position the engine on the bench, magneto side up. Hold the magneto stationary with the stopper wrench (special tool) and, using a socket wrench, remove the magneto retaining nut and lock washer. (Fig. 6)
27. Mount the magneto puller (special tool) and holding the magneto stationary with the stopper wrench, remove the fly wheel magneto. **CAUTION: When mounting the magneto puller on the 90cc fly wheel magneto, insert the three attaching screws just far enough to engage two or three threads. If these screws are turned in too far, it is possible to damage the magneto coils.**

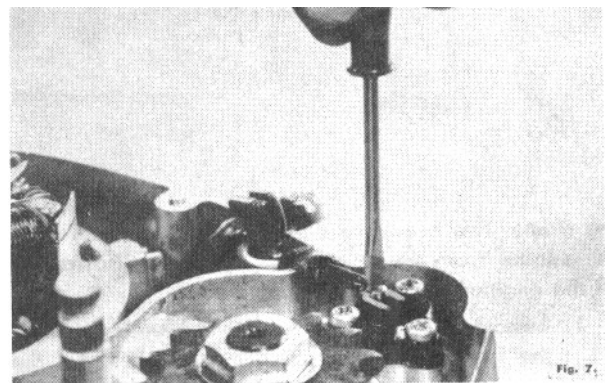

28. Remove the wire from the neutral gear switch. (Fig. 7)

29. Carefully mark the position of the magneto armature plate relative to the crankcase with a prick punch or with a felt marking pen. These reference marks will make it possible to reinstall the magneto armature plate in exactly the same position to avoid the necessity of major timing adjustments when the engine is reassembled. (Fig. 8)

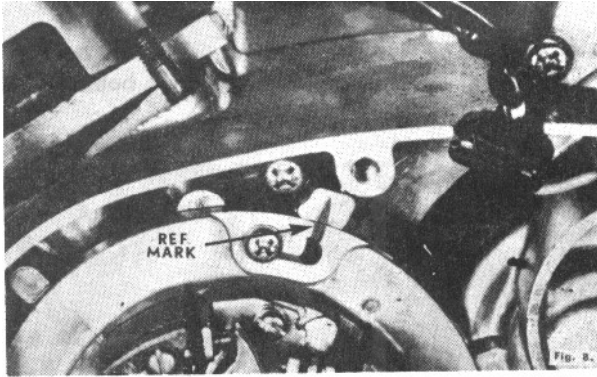

30. Remove the three armature plate attaching screws and remove the magneto armature plate.
31. Remove the three neutral gear switch cover mountings screws and remove the switch cover. Remove the brass contact located under the cover. This contact is fitted to the end of the shift drum shaft.
32. Turn the engine over so that the carburetor side faces up and remove the transmission case cover screws.
33. With the screws removed, carefully remove the transmission case cover. **CAUTION: Some oil will remain in the transmission case so use caution in removing the transmission case cover to avoid spilling this remaining oil.**
34. Remove the 6 clutch thrust plate bolts from the top of the clutch assembly. Remove the thrust plate. (Fig. 9)

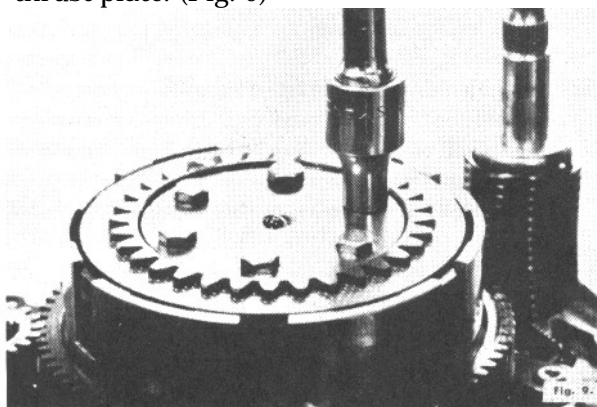

35. Remove the 6 clutch springs.
36. Flatten the up turned sides of the bend washer and remove the clutch retaining nut on the 90cc engine after shifting the transmission into first gear. Use the shift lever to shift the gears rather than a pliers to avoid damaging the splined end of the gear shift shaft. The sprocket stopper (special tool) must be slipped over the gear shift shaft on the opposite side of the engine and the steel pegs on this special tool are positioned between the teeth of the small sprocket. This holds the sprocket stationary, enabling you to remove the clutch retaining nut. (See figure 10). On the 50cc and 60cc rotary valve engines, remove the clutch retaining snap ring to remove the clutch assembly.

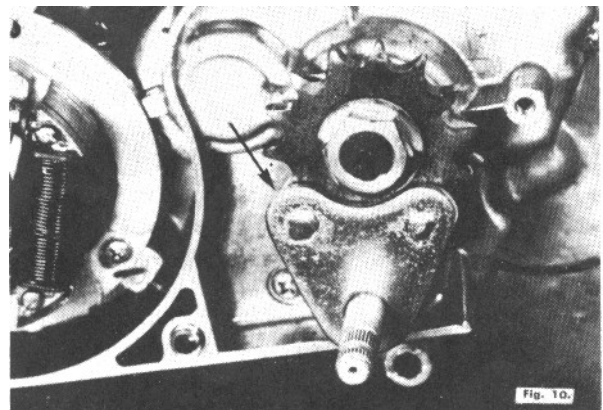

37. Remove the clutch assembly as a unit. **NOTE: On more recent models of the 90cc series, a thrust spring fits over the drive gear of the clutch. In these models, remove the clutch bracket, the splined washer, lift out the gear drive assembly, and then remove the thrust spring.**
38. With the clutch wrench (special wrench), remove the pinion gear nut from the end of the crankshaft. (On the newer models this retaining nut can be removed with a socket wrench.) **CAUTION: This is a left hand thread. The crankshaft can be kept from rotating during the removal of the pinion gear retaining nut if the piston seat is put in place.**
39. Remove the pinion gear from the end of the crankshaft.
40. Remove the 6 rotary valve cover screws and remove the rotary valve cover.

41. To remove the rotary valve disc, insert your finger up through the bottom of the fuel inlet port and gently dislodge the rotary valve disc from the crankshaft collar. If a screw driver is used to assist in removing the disc, use extreme caution to avoid damaging any part of the rotary valve cavity. (Fig. 11)

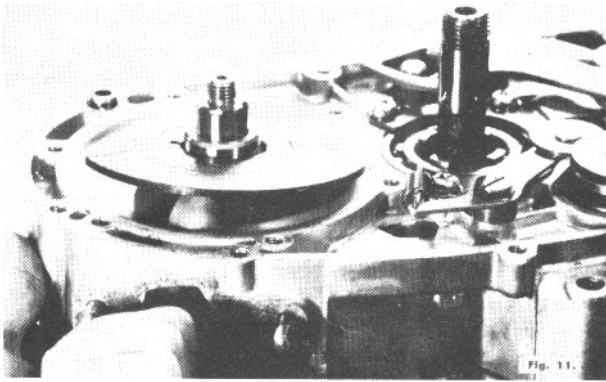

42. Remove the crankshaft collar and locating pin. The locating pin may be removed with a needle-nosed pliers.
43. Remove the washer and spring guide from the kick starter shaft.
44. Unhook the upper spring hook on the kick starter return spring by striking the upper end of the spring on the side opposite the spring hook. This will pop the spring hook from the hole in the kick starter shaft.
45. Unhook the lower end of the kick starter return spring from the crankcase and lift off the spring.
46. Using the circlip expander (special tool) remove the circlip from the kick starter shaft.
47. Using an open end wrench, remove the shift drum stopper pivot screw (Fig. 12). Unhook the shift drum stopper spring and remove the shift drum stopper. Inspect it for bends or abnormal wear. The disc on the end of the shift drum stopper should rotate freely.

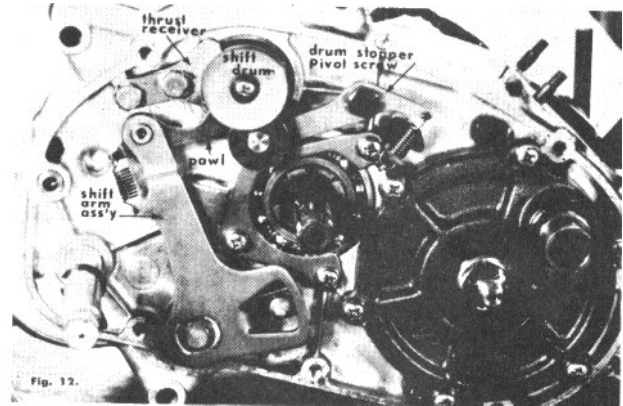

48. Lift the shift arm pawl free of the shift drum and holding it in this position, carefully withdraw the shift arm and shaft assembly. Inspect the shift arm assembly for bends, damage or abnormal wear. Remove the thrust receiver.
49. Position the engine on the bench with the magneto side facing upwards and remove the crankcase retaining screws. It may be necessary to use an impact driver to remove these screws as they are inserted very tightly. The impact driver will enable you to remove the screws without damaging the screw heads. See tool list, figure 1. (The drive sprocket should be removed as soon as the engine is turned magneto side up.)
50. With all crankcase retaining screws removed, carefully tap the crankcase with a soft faced hammer to break the gasket seal and separate the crankcase halves.
51. Carefully lift out the two transmission shafts and gears together with the shift drum-shift fork assembly.
52. Remove the shift drum/shift fork assembly from the transmission gears and inspect the shift forks for bends or abnormal wear. (Fig. 13)

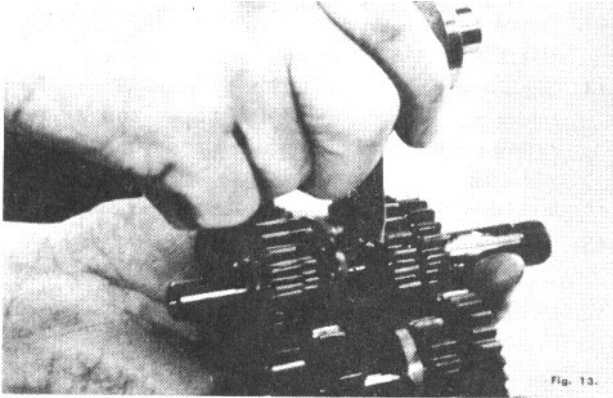

53. Inspect the two transmission shafts and gears to be certain that they are all in good condition. Further disassembly of the transmission is not necessary unless one or more of the gears must be replaced. If this is necessary, carefully note the position of the gears on the shaft before removing them for replacement. (Fig. 14)

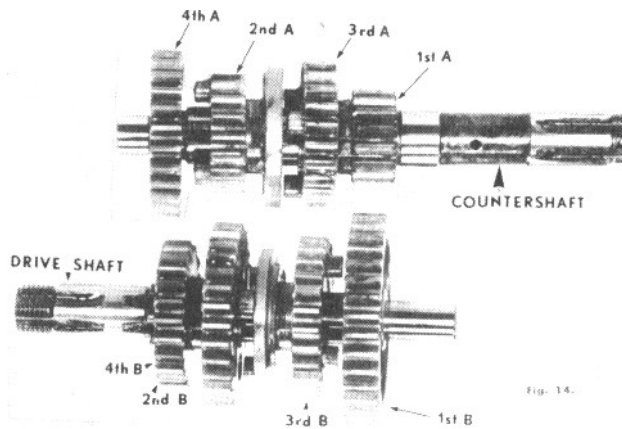

54. Remove the kick starter intermediate gear which remains in the crankcase half after the transmission shaft assembly has been withdrawn. Note that there is a spacer above and below this gear. Keep these spacers with this gear to facilitate reinstallation. (Fig. 15)

55. Withdraw the kick starter shaft and gear assembly. Notice that there is a spacer on the end of this shaft. Keep the spacer with this shaft to facilitate reassembly.

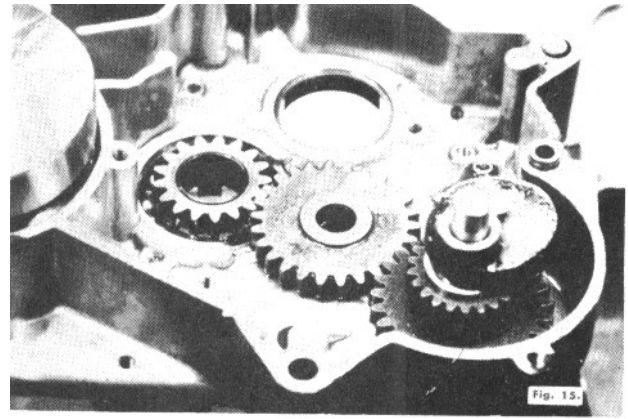

56. Withdraw the crankshaft assembly. Notice that spacing shims are used on either side of the crankshaft balance assembly. (Fig. 16) If the same crankshaft is to be replaced, keep these spacers on the crankshaft so that the crankshaft end play will not be affected. The number and thickness of spacers on this crankshaft varies from engine to engine. Occasionally the spacing shims will stick to the crankshaft bearings. Inspect the bearings carefully to be certain that these shims have been removed from both the crankcase sections if the oil present has caused them to adhere to the bearings.

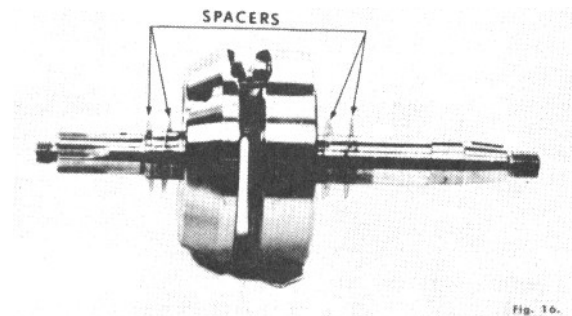

This completes the disassembly operation. Wash all parts (except magneto armature plate) in a cleaning solvent and inspect all bearings and oil seals. If it is necessary to replace bearings, the crankcase must be heated with a small torch in the vicinity of the bearings to expand it sufficiently to allow the bearing to be removed and replaced. When using a torch, keep the torch constantly in motion to avoid melting the crankcase castings.

If oil seals are to be replaced, coat them liberally with oil and tap them into place with a small hammer. Before beginning the reassembly operation, oil all bearings and oil seals thoroughly.

II. REASSEMBLY

All parts installed inside the two crankcase halves are installed into the magneto clutch section.

1. Install the kick starter shaft and gear assembly. Position the pin on the ratchet arm into the boss provided for it in the crankcase half.
2. Oil the kick idler gear assembly thoroughly. This gear need not be removed from the transmission case during disassembly as it is pressed into the counter shaft (clutch shaft) bearing. It is very unlikely that this gear will ever be replaced during the life of the engine.
3. Reinstall the kick starter intermediate gear positioning the spacers above and below the gear. These spacers are identical and can be identified since the hole in the spacer is the same size as the hole in the gear. Place it in mesh with the kick idler gear and the kick starter shaft gear and oil the gears. (Fig. 15)
4. We are now ready to install the transmission shaft assemblies and the shift drum/shift fork assembly. Before doing so, familiarize yourself with the positions into which the various shafts and the shift drum will be inserted by studying figure 15.
 - The splined end of the countershaft (the shaft with the smaller gears) will be inserted through the kick idler gear, the gear that is pressed into the countershaft bearing.
 - The end of the drive shaft will be inserted into the kick starter intermediate gear, the one which was installed with the spacers above and below it. The splined end of the shaft will point up and the small sprocket will be attached to it when the crankcase sections are joined. The large diameter end of the shift drum will be inserted into the large hole in the casting located directly above the kick idler gear and the kick starter intermediate gear.
5. Align the countershaft and drive shaft gears so that all gears are in mesh. Plan your installation of the shafts so that the longer end of the countershaft extends through the bottom of the crankcase section. Now insert the shift forks into the slots of the sliding gears of the transmission.

6. Holding both shafts and shift drum together as a unit, install the transmission assembly into the crankcase half. When the shafts have been partially inserted, rotate them slightly to mesh all gears and properly position the shafts.
7. Install the two remaining spacers, one on the end of the countershaft and the other on the end of the kick starter shaft.
8. Be certain that the crankshaft end play shims are positioned on both sides of the crankshaft balance and install the crankshaft. See figure 16. If a new crankshaft has been installed, it will be necessary to put the crankcase gasket into position, install the other crankcase section and insert several of the crankcase retaining screws tightly. The crankshaft should now be checked for end play. If there is more than .010" to .015" of end play, additional shims must be added to the crankshaft.
9. Install a new crankcase gasket locating it on the steel positioning pins. Install the second crankcase section. Again check transmission shaft rotation to be certain that the shafts turn freely. If found to be ok., reinstall the crankcase retaining screws and tighten them securely.
10. Trim the excess portion of the crankcase gasket flush with the cylinder seat.
11. Install the spacer on the shift arm shaft and position the shift arm shaft assembly into the crankcase. (Fig. 17)

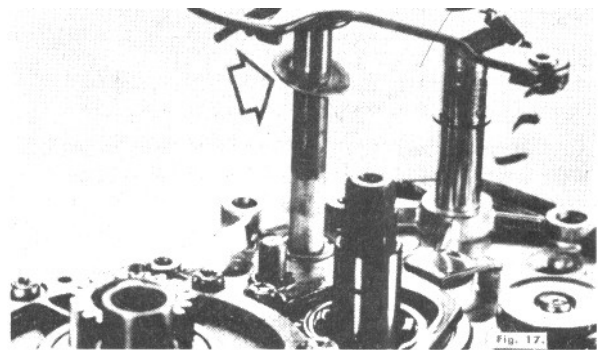

12. Insert the shift arm pawl into the shift drum assembly. Install the thrust receiver and bend the tabs on the tab washer against the flats of the bolts when the mounting bolts have been secured. This tab washer prevents the bolts from loosening during engine operation. (Fig. 12.)
13. Install the shift drum stopper, collar and retaining screw. Connect the drum stopper

return spring before inserting the retaining screw. The collar goes beneath the shift drum stopper. Tighten the shift drum stopper pivot screw securely.

14. Install the snap ring on the kick starter shaft.
15. Using a needle-nosed pliers, install the crankshaft collar locating pin into the crankshaft.
16. Install the crankshaft collar over the locating pin.
17. Install the rotary disc valve after coating it and the valve cavity liberally with oil.
18. Carefully check the large "O" ring around the outer perimeter of the rotary valve cover and check the center oil seal to be certain that they are in good condition. (Fig. 18) Install the rotary valve cover and the 6 retaining screws.

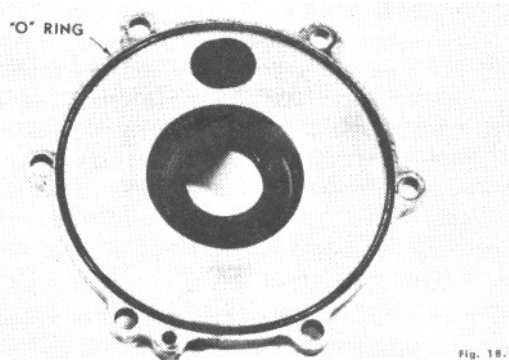

19. Install the drive sprocket, sprocket washer and retaining nut onto the transmission drive shaft. Tighten the nut finger tight. Put the sprocket stopper (special tool) in position and tighten the retaining nut securely. Bend the tabs of the washer against the flats of the retaining nut to prevent its loosening while the machine is being operated.
20. Install the clutch collar on the transmission countershaft after oiling the collar liberally and checking it for freedom of movement. (Fig. 19) **NOTE: On newer models, the clutch collar is built right into the shaft thereby eliminating it as a separate component.**

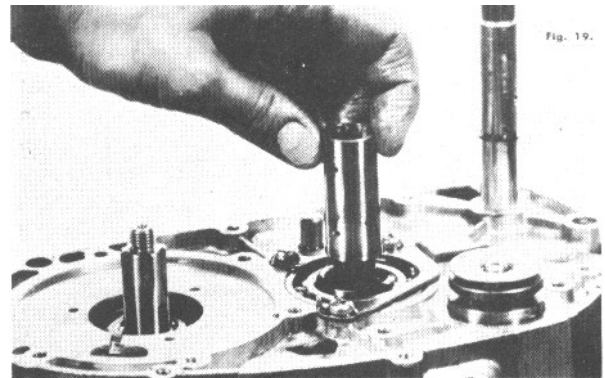

21. Install the clutch assembly onto the countershaft and countershaft collar. Rotate the clutch slowly while holding the sprocket stationary in order to engage the drive dogs. To positively engage the drive dogs, rotate the kick starter shaft. When the clutch is properly installed, approximately 1/2 inch of the transmission countershaft will protrude through the clutch assembly. (Fig. 20) **NOTE: On newer models, place the thrust spring over the clutch drive gear, install the clutch assembly, except for the clutch bracket, onto the countershaft, replace the splined washer, and install the clutch bracket.**

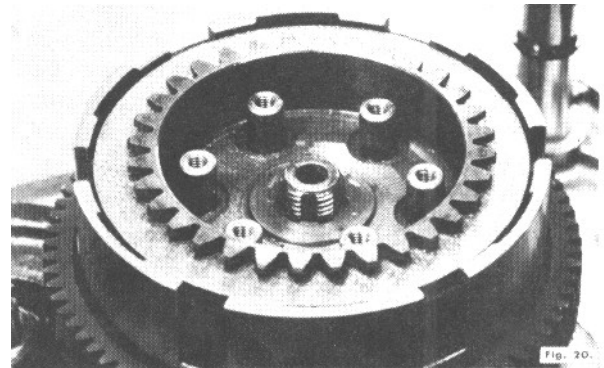

22. With the sprocket stopper in place, install the clutch retaining washer and nut and tighten the retaining nut securely on the 90cc engine. Bend the tabs of the washer against the flats of the nut to prevent rotation of this nut during engine operation. On the 50 and 60cc engines, install the clutch retaining spring clip.
23. Install the kick starter return spring, spring guide and spacer.
24. Install the pinion gear onto the crankshaft with the undercut side of the gear facing up. With the piston seat in place, tighten the pinion gear retaining nut securely. Remember that this is a left hand thread.

25. Install the 6 clutch springs and reinstall the clutch thrust plate using the 6 thrust plate bolts. Tighten them securely.
26. If the clutch release push screw has been removed from the transmission cover, reinstall it from the inside so that the flats of the screws (as seen from the outside of the transmission cover) are in a relatively horizontal position with the back of the release push screw flush with the inside of the transmission case cover. (Fig. 3) Be certain that the thrust bearing has been liberally coated with grease and inserted into the push screw. (Fig. 21)

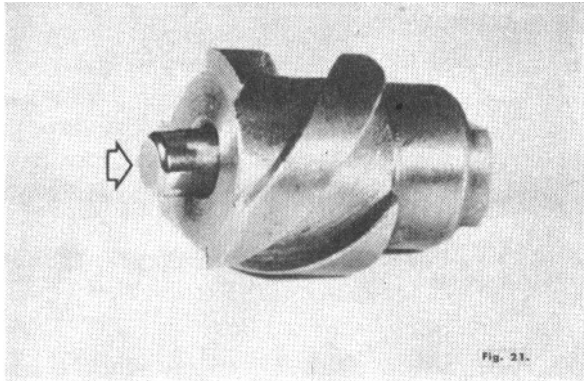

27. Position the transmission cover gasket on the locating pins. Install the rubber "O" ring on the carburetor inlet adapter, which is a part of the rotary valve cover. (Fig. 22)
28. Install the transmission case cover by securing all the transmission case cover screws.
29. Turn the engine assembly over and install the neutral light switch gasket and contact. With the transmission in neutral gear, check to be certain that the contact in the switch cover touches the contact which is installed onto the end of the shift drum shaft. Secure the cover.
30. Position the magneto armature plate making use of the reference marks which you made prior to removing this assembly. (Fig. 8) Secure the plate with the 3 armature plate screws.

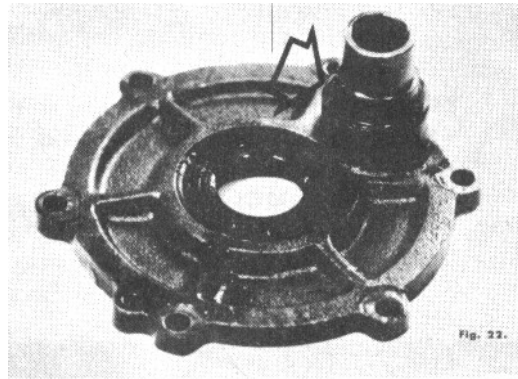

31. Reattach the neutral gear switch wire to the switch cover. Tighten the wire retaining screw. (Fig. 7)
32. Install the flywheel onto the crankshaft and, holding the flywheel stationary with the stopper wrench, tighten the flywheel retaining nut securely.
33. Install the piston pin onto the connecting rod to check for fit. It should be snug but rotate easily. Replace the pin and bushing if necessary. Oil the bushing thoroughly before installing the piston pin and piston.
34. Install the piston pin and piston. When installing the piston, the letters "EX" are to face the exhaust port (front) on the cylinder. It is important to position the piston this way since the piston pin hole is slightly off center for improved performance. If the piston is installed backwards, a loud knocking sound will be heard at low speeds. (Fig. 23)

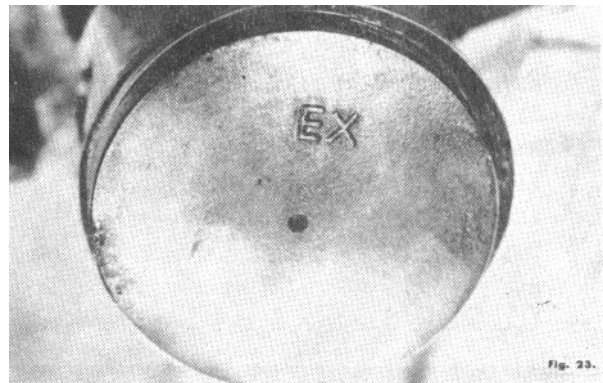

35. Install the piston pin retaining clips.
36. Check to see that the piston rings are properly installed. The chrome plated ring is the upper ring and the cast iron ring is the lower ring. The rings are to be positioned on the piston so

that the locating pin on the piston is located in the ring gap. (Fig. 24) The notch in the ring gap should face up. If the notch faces down, the rings cannot be compressed enough to permit installation of the cylinder.

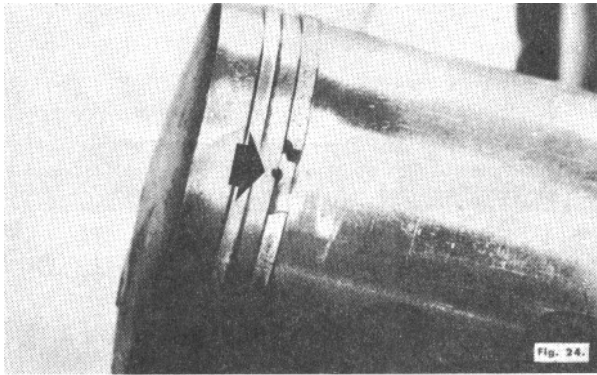

37. Install the cylinder onto the mounting studs and install the lockwashers and nuts securely.
38. Install the cylinder head gasket and cylinder head. Four flat washers are used under the cylinder head nuts. Tighten the head nuts progressively and evenly to 125 inch lbs. of torque.

The engine is now completely reassembled and ready for remounting in the cycle frame. The engine mounting procedure is to be done in the reverse order of the dismounting procedure.

BRIDGESTONE 175 DT ENGINE DISASSEMBLY AND REASSEMBLY

I. Removing Engine From Frame

1. Drain transmission oil into a suitably large container.
2. Raise the right hand rubber carburetor cap.
3. Remove the air cleaner duct from the carburetor cap.
4. Remove the carburetor cover from the right hand side of the engine.
5. Remove the rubber plug from the front of the carburetor enclosure and loosen the carburetor retaining bolt.
6. Remove the right hand carburetor. It can be allowed to hang suspended from the throttle cable.

7. Loosen the clutch adjusting screw lock nut and remove the clutch adjusting screw.
8. Remove the clutch release arm and disconnect it from the clutch cable.
9. Unscrew the clutch cable adjusting screw all the way out of the engine.

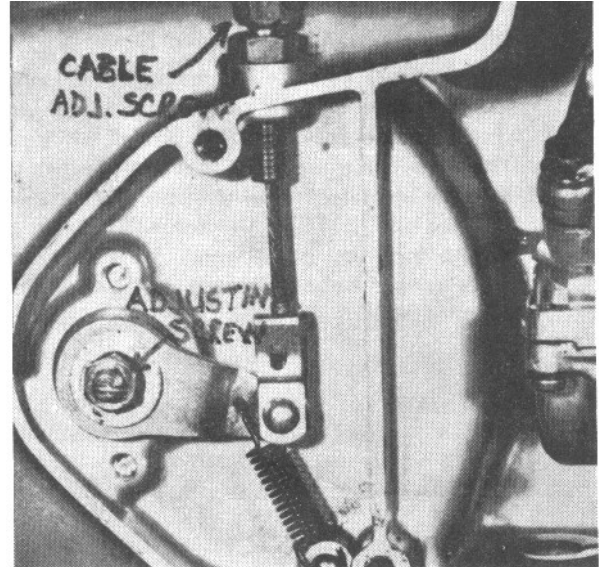

10. Remove the kick starter lever.
11. Remove the cover plate on which the transmission selector lever is mounted.
12. Remove the gear shift pedal.
13. Raise the carburetor rubber cap from the top of the left carburetor enclosure.
14. Remove the air cleaner duct from the rubber carburetor cap.
15. Remove the left carburetor cover.

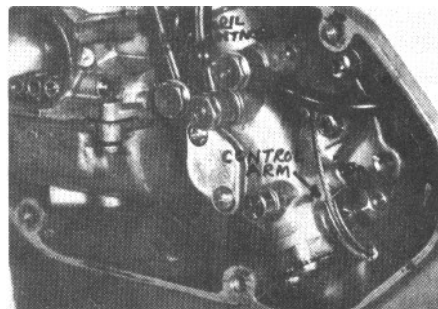

16. Remove the left carburetor.

17. Remove the control cable from the oil injection pump control arm by prying the cable attaching bracket open with a screw driver.
18. Remove the throttle cable adjusting screw out from the transmission cover.
19. Remove the main oil pump supply line from the fitting on the oil pump and plug this oil line with a screw to prevent the oil from draining out of the supply tank.
20. Remove the saddle.
21. Remove the side cover from the left hand side of the cycle.
22. Disconnect the wiring running between the AC generator and the battery. These wires are snap connected.
23. Disconnect the wires from the terminals on the selenium rectifier. The wiring harness can then be pulled free of the cycle.
24. Disconnect the master link on the drive chain and remove the chain from both sprockets.
25. Disconnect the exhaust pipe clamps and swing the exhaust pipes down, clear of the engine.
26. Remove the air cleaner.
27. Remove the four engine mounting bolts from the mounting plates at the front of frame assembly.
28. Remove the lower rear engine mounting bolt.
29. Remove the upper rear engine mounting bolt. This bolt should be withdrawn with a pliers since all of the engine weight is now bearing against this last bolt.
30. Remove the engine from the cycle frame.

II. ENGINE DISASSEMBLY

1. With the engine placed on a suitable bench, remove the cylinder heads and cylinders.
2. Remove the piston pin retaining clips and, using the piston pin pusher from the Bridgestone Special Tool Kit, remove the piston pins and pistons.

3. Remove the connecting rod needle roller bearings.
4. Remove the oil lines from the oil pump.
CAUTION: If the union bolts are removed from the banjo connectors use care to avoid losing the ball check valves from the union bolts. **NOTE:** The earliest BS175 models were not equipped with ball check valves in the union bolts.
5. Remove the two screws which mount the oil pump to the oil pump gear box.

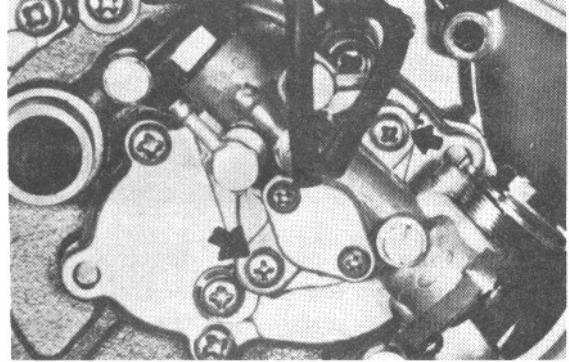

Fig. 27

6. Remove the four oil pump gear box mounting screws. It will be necessary to rotate the pump to remove the last two screws.
7. Remove the oil pump and gear box assembly from the rotary valve cover.
8. Remove the left hand crank case cover.
9. Remove the rotary valve cover. **CAUTION:** If it is necessary to pry this cover to remove it from the crankcase, use extreme caution. Pry only in the area immediately adjacent to rotary valve cover locating pin. Prying may cause damage to the crankcase which will result in leaks.

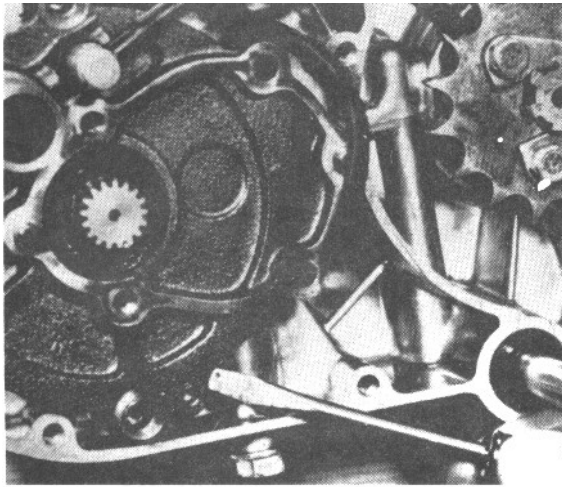

Fig. 28

10. Remove the rotary valve from the crankshaft. Removal can be facilitated by inserting your index finger through the fuel intake port from inside the crankcase and pushing the valve off the crankshaft spline. It is not necessary to remove the crankshaft spline.

11. Turn the engine around so that you can work on its right hand side. Remove the transmission cover mounting screws and the transmission cover.

12. Remove the clutch thrust plate by removing the six mounting bolts.

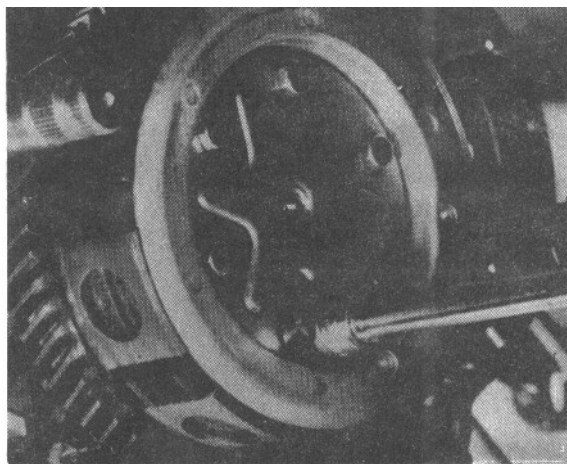

Fig. 29

13. Remove the clutch springs.

14. Place the transmission in any gear. With a small chisel and hammer, flatten the bend washer beneath the clutch retaining nut.

15. Place the clutch stopper, a special tool, in place to hold the clutch stationary while the clutch retaining nut is removed.

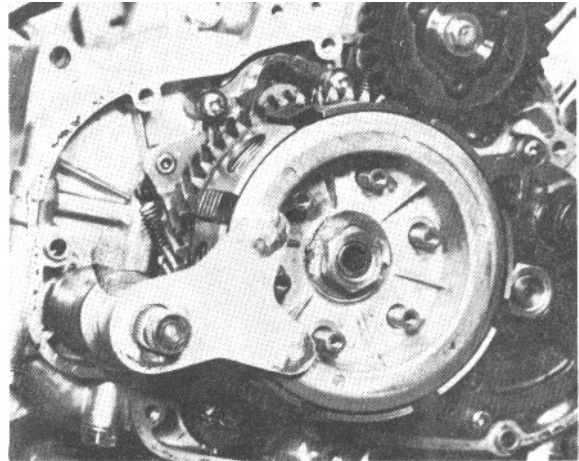

Fig. 30

16. Loosen, but do not remove, the generator gear mounting bolt.

17. Remove the clutch as a unit, by placing the fingers of both hands around the clutch gear while holding the center of the clutch in position with your thumbs. (On more recent models of the 173 DT, a thrust spring fits over the drive gear of the clutch. On these models, remove the retaining nut, the clutch hub, the splined washer, the remaining clutch assembly, and then the thrust spring, in that order.)

18. Insert the aluminum piston seat under the upper end of one connecting rod to hold the crankshaft stationary and loosen the pinion gear retaining nut. **THIS IS A LEFT HAND THREAD.** Remove the retaining nut and the gear from the shaft.

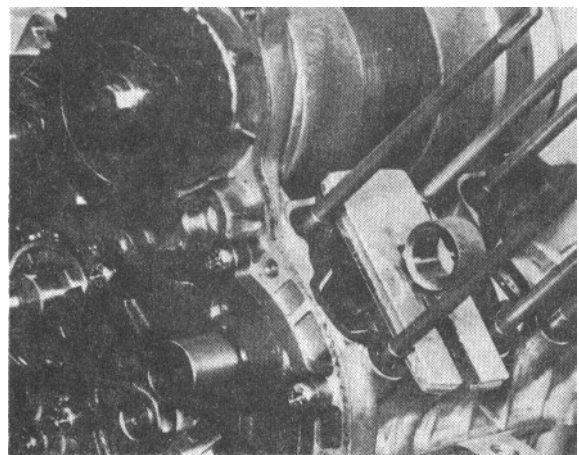

Fig. 31

19. Remove the right rotary valve cover.

20. Remove the right rotary valve and collar. It is not necessary to remove the spline from the crankshaft.

21. Mount the flywheel puller in the threaded holes provided in the generator gear and with the center bolt of the special tool bearing against the generator gear bolt, remove the generator gear from the tapered generator shaft.

- B/S 173 models after serial No. 16G 11761 are equipped with a timing idle gear also. This gear is removed at this time.

22. Remove the drum stopper retaining bolt and drum stopper. Do not lose the spacer washer beneath the drum stopper.

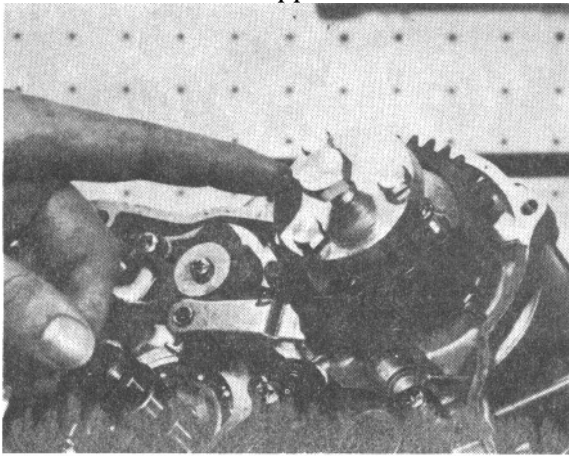

Fig. 34

23. Pull the shift pawl free of the shift drum and remove the entire gear shift shaft assembly. Be certain that: the spacer is removed with the shaft. It sometimes adheres to the crankcase due to oil surface tension.

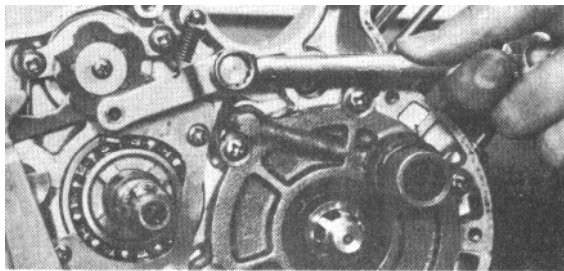
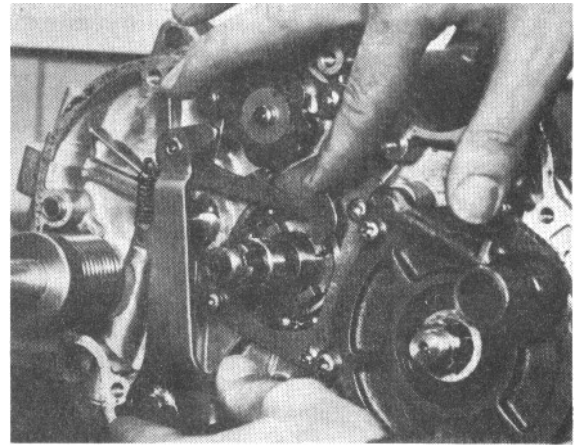

Fig. 33

24. Remove the kick starter spring seat and the kick starter shaft return spring.

25. Remove the three screws from the bearing retainer and remove the bearing retainer.



26. Remove the AC generator from the top of engine assembly. **NOTE: It is not necessary to remove the generator in order to split the crankcases.**

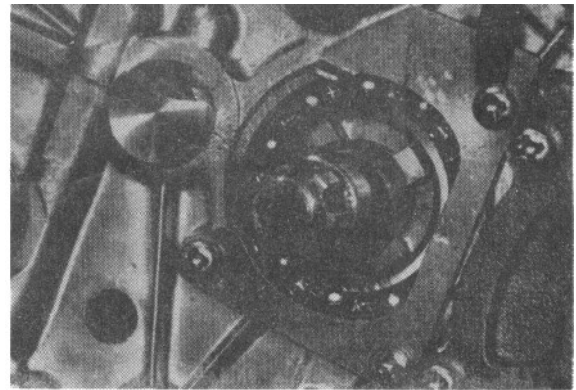

Fig. 35

27. Invert the engine and remove all of the bolts which join the crankcase sections.

28. Separate the crankcase sections.

29. Remove the crankshaft assembly.

30. Remove the transmission clutch shaft.

31. Remove the transmission drive shaft. If it is necessary to disassemble the gears from the transmission shafts, carefully note their positions before any gears are removed so that you will be able to reassemble them in the same order.

32. Remove the neutral gear switch cover from the shift drum and remove the contact from the shift drum.

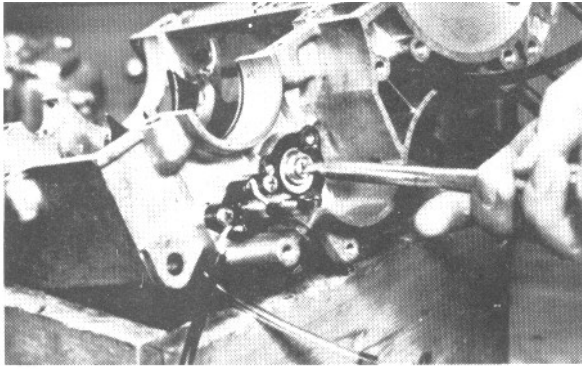

Fig. 36

33. Lift the fifth speed shift fork to the right so that the guide pin spring and spring seat can be removed from the shift fork.
34. Holding the neutral switch in place on the end of the shaft, remove the transmission selector shaft from the crankcase.
35. Remove the oil splash shield from the transmission case.
36. Remove the cotter pins from the shift forks.
37. Using a screw driver, tip the shift fork guide pins out of the groove in the shift drum.

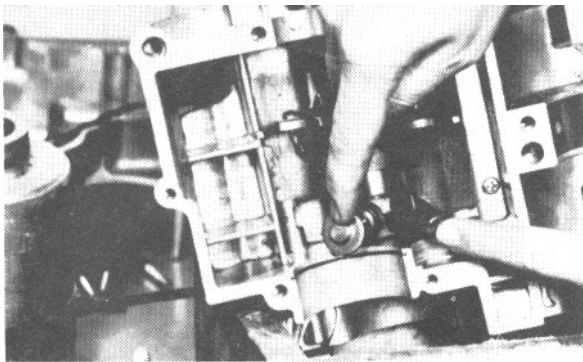

Fig. 37

38. Remove the thrust receiver mounting screws and pull the shift drum and thrust receiver out of the transmission case. Hold the shift forks stationary while the shift drum is being removed. Remove the shift forks from the transmission case.
39. Remove the guide pins from the shift forks and inspect them for wear. Notice that the guide pins are equipped with roller ends. These roller ends ride in the grooves in the shift drum.

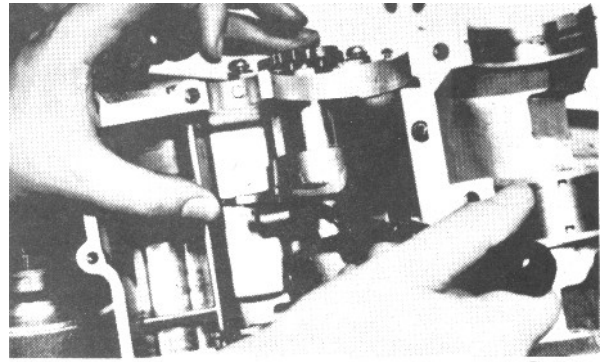

Fig. 39

40. Remove the spring clip which retains the kick starter shaft in the lower crankcase section.

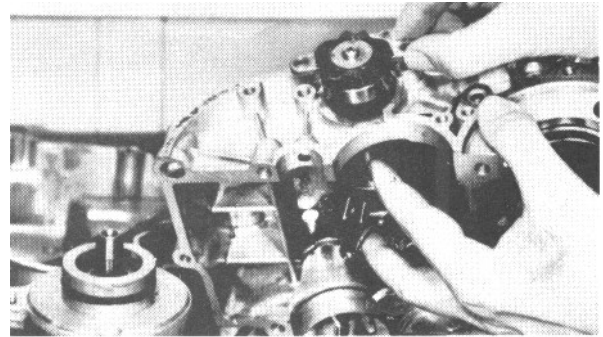

Fig. 40

41. The kick starter shaft can then be withdrawn from the crankcase section. Remove the ratchet assembly from the crankcase section.

Before reassembling the engine, wash all parts in a cleaning solvent; inspect for abnormal wear.

III. ENGINE REASSEMBLY

1. If the neutral switch was removed from the transmission selector lever shaft, re-install the switch assembly onto the transmission selector lever shaft. Be certain that the contact is not out of round and that it is properly seated in the groove provided for it on the plastic portion of the shaft.
2. Install the shaft, onto which the switch assembly has been mounted, into the transmission case. Secure it with two Phillips head screws.
3. Connect one lead of a continuity tester to one of the leads from the switch cover and ground the other continuity tester lead. Rotate the selector lever shaft until the continuity tester lights. Connect the lead of the continuity to the other switch case lead and with the other

continuity tester lead grounded, again rotate the shaft until the continuity tester bulb lights. If the bulb will not light in both positions, check the installation of the switch contact and, if it is out of round, replace it.

4. Place the fifth speed shift fork into the transmission case so that the guide pin boss faces the transmission selector lever shaft.
NOTE: For installation of the modified shift fork, which appears on models after serial No. 16B 04739, see page 38, under TRANSMISSION.

3. Fit the two main shift forks (which are identical and interchangeable) together and place them in the transmission case.
6. Place the thrust receiver in position in the end of the shift drum and insert the shift drum through the transmission case and through all three shift forks. Secure the thrust receiver with the two mounting screws and star washers.

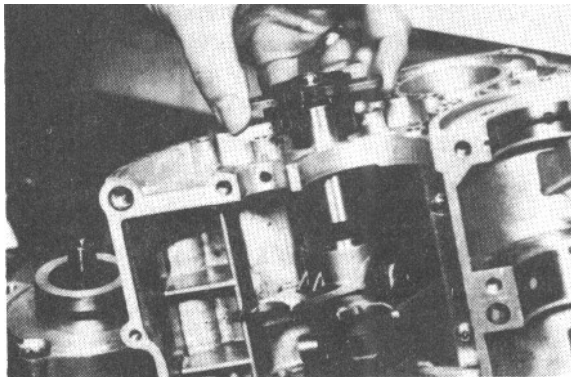

Fig. 41

7. The guide pins are inserted into the main shift forks so that the roller ends are positioned in the shift drum groove. Install the cotter pins in the shift forks so that the cotter pins may be spread around the curved part of the guide pin bosses.
8. Install the fifth speed guide pin spring and guide, tipping the shift fork to your left so that the guide pin is retained in the notch in the selector lever shaft.
9. Install the neutral switch contact onto the end of the shift drum.

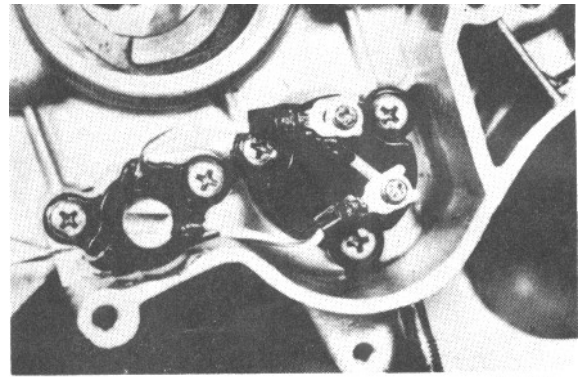

Fig. 42

10. Install the neutral switch cover over the shift drum contact. This cover must be installed so that the wires from the terminals on the selector shaft switch marked "4" and "5" are connected to the shift drum switch cover terminals marked "4" and "5", respectively, without crossing the wires.
11. Placing the selector lever shaft and sprocket cover in position, turn the selector lever shaft to the four speed position. Connect one lead of the continuity tester to the yellow wire with green tracer running from the main neutral switch. Ground the other lead. Rotate the shift drum until the gears are in the neutral position and the continuity tester light goes on. Place the transmission in any gear. Using the selector lever, move the shaft to the five speed position. Rotate the shift drum until the continuity tester light comes on. If you do not get a light in both the four speed and five speed neutral positions, inspect the contact on the shift drum. Replace if necessary.
12. Install the crankshaft assembly.
13. Install the oil splash shield.
14. Install the transmission drive shaft locating the groove on the large ball bearing onto the bearing locating ring in the crankcase section. The bushing on the other end of the shaft is located on a knock pin in the crankcase section.

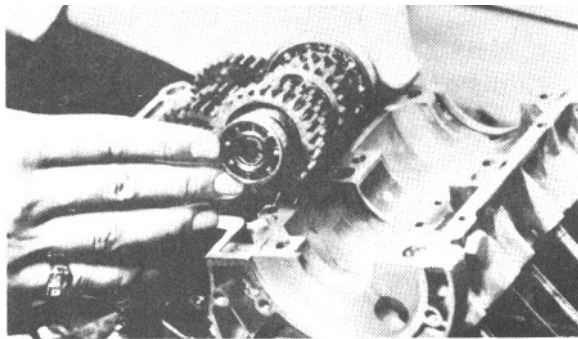

Fig. 43

15. Install the clutch shaft. Note that the smaller ball bearing on this shaft has the one sealed side. The sealed side of the bearing is to face the gears. The open side faces out. Note that the clutch shaft is hollow. Oil is deflected by the splash shield into the cavity next to the sealed bearing. It then passes through the shaft, lubricating the gears on the shaft. Check the shafts for freedom of rotation.

16. Place the thrust washer in the kick starter ratchet gear and install the ratchet arm and pawl assembly on top of the thrust washer.

17. Holding the kick starter gear and ratchet stopper assembly in position in the crankcase section, install the kick starter shaft into the crankcase. Locate the splined portion of the shaft into the kick starter ratchet arm so that the countersunk hole in the shaft faces up when the ratchet arm is resting against the ratchet stopper. This positioning of the shaft is necessary to secure the proper tension on the kick starter return spring when it is installed. Be certain that the small thrust washer in place on the end of the shaft is inserted into the boss provided for it in the crankcase.

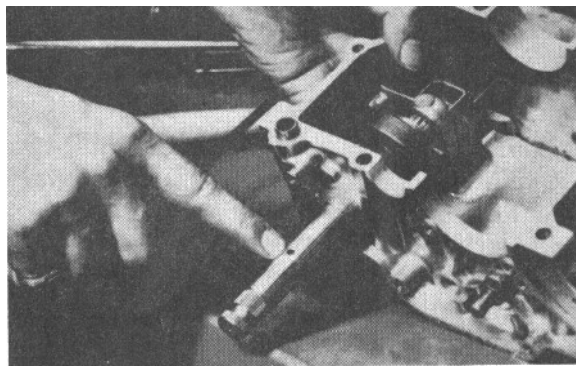

Fig. 44

18. Insert the spring clip onto the shaft behind the ratchet stopper.

19. Coat the abutting surfaces of the two crankcase sections with a rubber-base gasket compound such as Pliobond.

20. Install the 2 knock pins into the upper crankcase section and join the two sections. Place all of the joining bolts into the holes provided for them and check to see that approximately $\frac{1}{2}$ inch of thread is available between the bolt head and the crankcase before tightening any of the bolts.

21. Tighten all bolts finger tight.

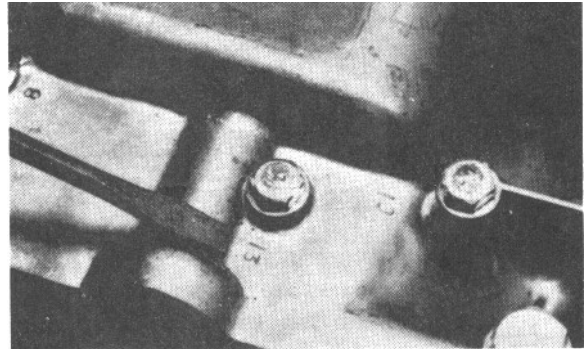

Fig. 45

22. Then tighten the bolts in the tightening order which is embossed on the crankcase next to the bolt holes. The bolts with the large heads are torqued to 120 inch pounds and the smaller bolts are torqued to 60 inch pounds.

23. Install the bearing retainer on the right hand side of the engine assembly with the three screws provided.

24. Check to be certain that the spacer washer is on the gear shift shaft assembly and install the shaft onto the transmission case. Place the shifter pawl into the shift drum. Check it for freedom of movement.

25. Install the shift drum stopper. Note that a spacer washer is used behind the stopper and the shoulder bolt passes through the drum stopper and spacer and threads into the boss in the crankcase. Connect the drum stopper spring and check the drum stopper for freedom of movement.

26. Install the right rotary valve. Note that the rotary valves are interchangeable and are marked with the letters "L" and "R". The rotary valve on the right hand side of the engine is installed so that the letter "R" is aligned with the pin in the crankshaft. **Note:**

Left and right sides of the engine are determined by facing the direction in which the machine travels.

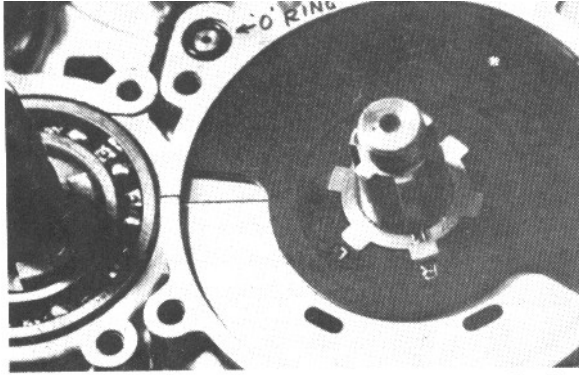

Fig. 46

33. The edges of the washer are bent up against the flats of the nut to prevent its loosening during operation.
34. Install the six clutch springs and install the clutch thrust plate. Be certain that the ball bearing on the thrust plate faces out.
35. Install the pinion gear onto the crankshaft.
 - ALIGN THE MARKED TOOTH ON THE GEAR WITH THE PUNCH MARK ON ONE OF THE CRANKSHAFT SPLINES.
27. Install the small "O" ring which seals the oil passage for the oil injector to the right carburetor adapter.
28. Install the crankshaft collar.
29. Install the right rotary valve cover. Before installing check to be certain that the 100mm "O" ring is in good condition and in place in the groove provided for it in the rotary valve cover. Also check the condition of the center oil seal. The rotary valve cover is installed by aligning the pin

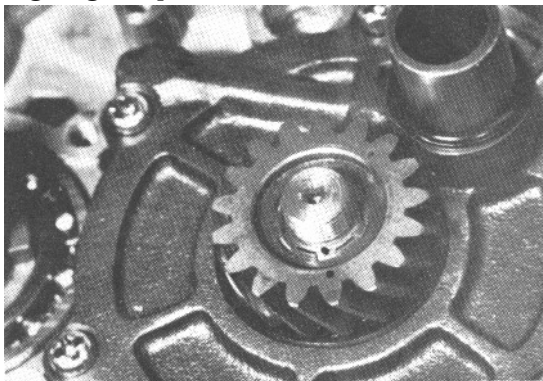

Fig. 47

30. Locate the two punch marks on the clutch gear. These marks are located between gear teeth approximately three inches apart.
31. Install the clutch onto the transmission countershaft. **NOTE: On newer models, fit the thrust spring over the clutch drive gear, install the clutch assembly, except for the hub, replace the splined washer, and then install the clutch hub.**
32. Secure the clutch with the bend washer and hex nut. The clutch stopper is installed to prevent the clutch from rotating during tightening of this nut.
33. The edges of the washer are bent up against the flats of the nut to prevent its loosening during operation.
34. Install the six clutch springs and install the clutch thrust plate. Be certain that the ball bearing on the thrust plate faces out.
35. Install the pinion gear onto the crankshaft.
 - ALIGN THE MARKED TOOTH ON THE GEAR WITH THE PUNCH MARK ON ONE OF THE CRANKSHAFT SPLINES.
 - THIS MARKED TOOTH MUST ALSO BE ALIGNED WITH THE LOWER OF TWO PUNCH MARKS ON THE CLUTCH.
 - Install the spring washer and hex nut. This is a left hand thread.

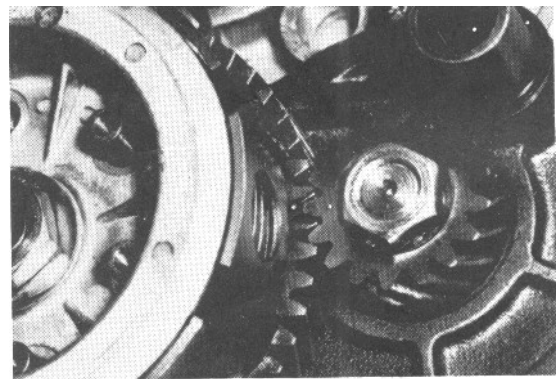

Fig. 48

36. Put the piston seat in place under the connecting rod upper end and tighten the pinion gear nut securely.
37. Turn the engine around so that you face its left side.

38. Install the generator strap and mount the generator. Do not tighten the generator mounting bolts securely.
39. Again, facing the right hand side install the generator gear so that the marked tooth on this red fiber gear is aligned with this upper most of the two marks on the clutch gear. Be certain that the generator gear is on the woodruff key in the generator shaft. **NOTE: THE POSITION OF THE PINION GEAR, CLUTCH GEAR, AND GENERATOR GEAR AS REFERENCED BY THE MARKED TEETH IS ESSENTIAL. IF THESE GEARS ARE NOT PROPERLY ALIGNED AND THE PINION GEAR IS NOT PROPERLY POSITIONED ON THE MARKED SPLINE OF THE CRANKSHAFT, IGNITION TIMING WILL BE IMPOSSIBLE.**

- **NOTE: The timing idle gear on those models after serial No. 16G 11761 is installed just prior to the generator gear. WITH THE PINION GEAR ALIGNED WITH THE CLUTCH GEAR, THE GENERATOR GEAR IS INSTALLED SO THAT THE PUNCH MARK ON THE GENERATOR GEAR ALIGNS WITH THE CENTER OF THE FIBER IDLE GEAR.**

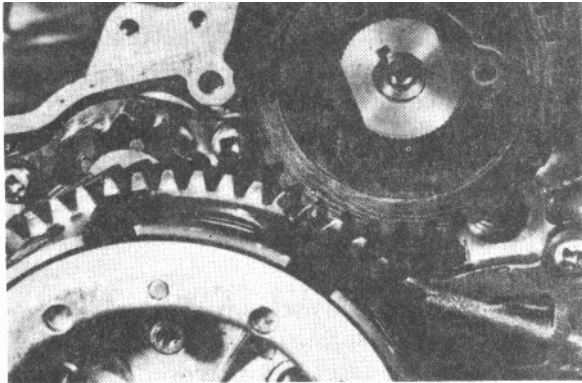

Fig. 49

40. Install the kick starter shaft return spring. Hook the lower end of the spring into the crankcase and hook the upper end of the spring into the countersunk hole in the starter shaft. The starter shaft is to be rotated clockwise and held in position while the spring is wound counter-clockwise to install it into the hole in the shaft.
41. Install the spring cap to prevent the spring from becoming unhooked.

42. Install the knock pins into the crankcase assembly and place a new gasket over the knock pins.
43. Install a new "O" ring on the carburetor adapter.
44. Coat the clutch release screw roller bearing with heavy grease to hold it in place in the release screw. Install the transmission cover and tighten the screw securely.
45. Turn the engine around so that you face its left side.
46. Coat the left rotary valve cavity with oil and install the left rotary valve aligning the letter "L" stamped on the valve with the pin in the crankshaft.
47. Inspect the left rotary valve cover to be certain that the large "O" ring is in place and that the center oil seal is in good condition.
48. Install the left rotary valve cover, locating it on the crankcase by means of the pin in the crankcase and the hole in the cover. Secure the cover with four short screws. The two remaining screws are not installed at this time because they also secure the oil pump gear case.
49. Using a new gasket install the oil pump and oil pump gear case assembly onto the left rotary valve cover, locating the gear box by means of the two pins in the rotary valve cover.
50. Install the four screws which secure the gear box to the rotary valve cover.
51. Install the screw on the left side of the oil pump which secures the oil pump to the gear box.
52. Remove the oil pump gear box oil level screw. This screw can be identified by the red fiber washer beneath it.
53. Using a pressure type oil can inject oil through the screw hole on the right side of the oil injection pump until oil is seen coming out of the oil level screw hole. **NOTE: The oil pump gear cavity on those models after serial No. 16G 11761 is lubricated automatically from the transmission.**

54. Replace the oil level screw and fiber washer and install the right hand oil pump attaching screw. Tighten securely.

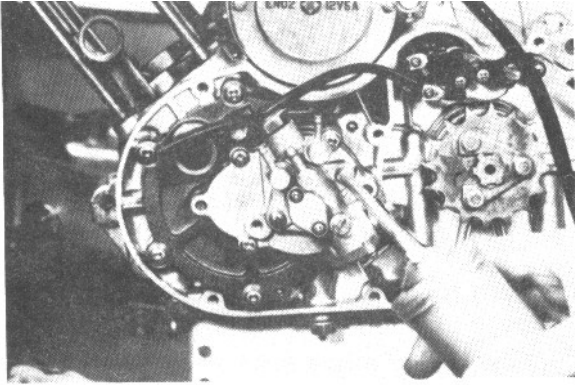

Fig. 50

55. Using the pressure type oil can, fill the right hand oil injection line before installing a line onto the right banjo connector. When tightening the banjo connector union bolts use caution, so as not to overtighten the bolts. These bolts are hollow and can be broken. Note that a washer is used on either side of all banjo connectors.
56. Install the left oil line onto the oil pump and onto the left rotary valve cover.
57. Install the left crankcase cover. It may be necessary to adjust the position of the oil lines when this cover is installed to be certain that there are no sharp bends in the oil lines.
58. Install the cylinder base gaskets onto the two sets of cylinder studs.
59. Install the piston pin needle bearings into the upper ends of the connecting rods and oil them generously.
60. Install the pistons.
61. Install the piston pins retaining clips. Make certain that they are securely seated in the grooves provided for them in the pistons.
62. Coat the cylinder walls with oil and install the cylinders onto the cylinder studs.
63. Install the cylinder head gaskets and cylinder heads. When installing the cylinder heads, position the heads so that the small key stone trademark on the underside of the cylinder head faces the front of the cylinder. Torque the cylinder nuts to 140 inch pounds.

IV. INSTALLING ENGINE INTO FRAME

1. Position the engine in the frame and install the two rear mounting bolts. Install the front mounting bolts and attaching plates and tighten securely.
2. Install the new gaskets and connect the exhaust pipes to the cylinders.
3. Install the clutch cable and cable adjusting screw into the crankcase assembly.
4. Install the clutch release arm onto the release screw after connecting it to the clutch cable. Connect the return spring to the spring pin.
5. Adjust the clutch cable until a center-to-center distance of $1\frac{1}{4}$ inches is obtained between the clutch release arm pivot pin and spring attaching pin. Tighten the cable adjusting screw lock nut securely.
6. Turn the clutch adjusting screw until approximately $\frac{3}{8}$ of an inch of lever free play is obtained. The free play is measured at the lever end. Tighten the adjusting screw lock nut.
7. Install the left carburetor.
8. Attach the control cable to the oil pump control arm. Bend the tab on the arm to secure the cable.
9. Adjust the control cable by turning the cable adjusting screw so that, at the full throttle position, there is approximately $\frac{1}{8}$ inch of clearance between the control lever and the stop pin. When this clearance is obtained, tighten the cable adjusting screw lock nut.
10. Attach the main oil supply line to the center banjo connector on the oil pump. You will recall that we previously plugged this line with a screw to prevent oil from running out of the supply tank.
11. Install the left carburetor cover using a new gasket.
12. Reinstall the drive chain and install the connecting link spring clip so that the open end of the clip faces the direction opposite of the direction chains rotation.

13. Reconnect the wiring between the AC generator, key switch, and rectifier. All connections are made color to color.
14. Reinstall the saddle.
15. Reinstall the air cleaner assembly.
16. Reinstall the left rubber carburetor cap and reinstall the ducts leading from the air cleaner to the carburetor caps.
17. Reinstall the right hand carburetor and carburetor cover, using a new gasket.
18. Before operating the cycle, perform the following operations:
 - A. Ignition timing
 - B. Fill transmission with 25 ounces of SAE10W30 motor oil.
 - C. Put one gallon of premixed fuel in the ratio of 20 parts of gasoline to one part of oil into the fuel tank. This mixture will lubricate the engine while the oil pump primes the oil lines. As soon as heavy exhaust is seen coming from the mufflers, the tank may be filled with regular gasoline.
 - D. Be certain that the oil supply tank is filled with Bridgestone 2-cycle oil.

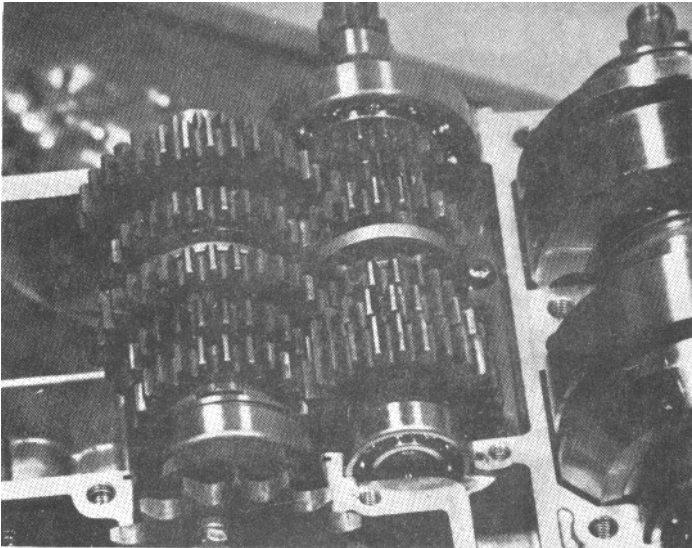

Fig. 51

CYLINDERS AND PISTONS:

- A. Construction and Operation:

The cylinders of the 30-60 SPT, 90 STD, 90 T, 90 M are of high-grade cast iron and accurately finished by honing.

In the 90 SPT and 175 DT, the cylinders are made of aluminum alloy. Cylinder walls are honed after hard chromium plating and then porous treated.

Because the carburetor is encased in the transmission case in the rotary disc valve engine, no intake port is required in the cylinder. (The intake of fuel is controlled by the opening and closing of the rotary valve.) The exhaust port is located in the forward part and the transfer ports in the right and left sides and rear part of the cylinder. The transfer port in the rear part of the cylinder is called the "boost" port. This booster port expels exhaust gas and induces fresh fuel/air mixture into the combustion chamber, increasing scavenging efficiency.

Fig. 52. Fuel intake system.

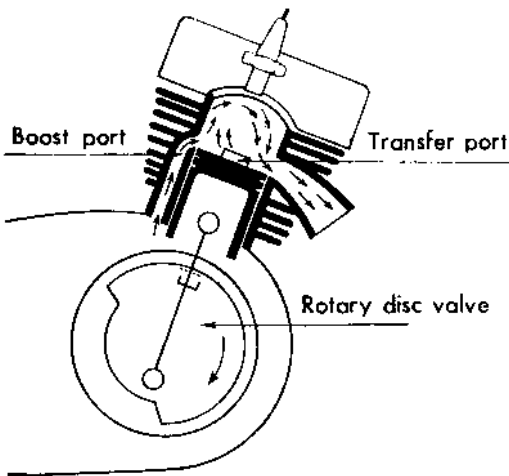
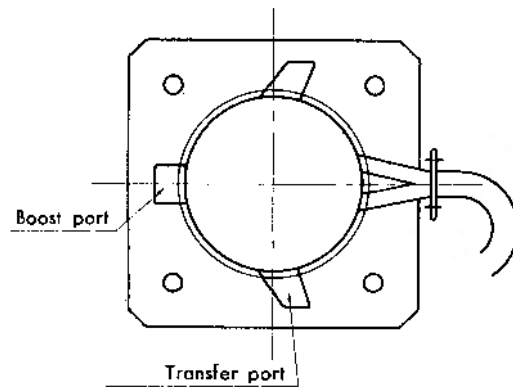

Fig. 53. Cross section cylinder.



The pistons are aluminum alloy, made to resist wear and yet maintain excellent mechanical property at high temperatures.

Pistons used in the cast iron cylinders are of high silicon aluminum alloy with a low coefficient expansion and light specific gravity.

Those pistons used in the aluminum cylinders are of low silicon/alloy content, with a lower heat expansion coefficient than the normal aluminum alloy pistons.

NOTE:

1. Pistons for the 90 STD, 90 T, 90 M could be used for replacement in the 90 Sport or 175 DT but only in cases of emergency. (They are of a harder material and will wear the chrome faster.)
2. Pistons for the 90 Sport and 175 DT are not interchangeable and cannot be used in the cast iron cylinders or the 90 STD, 90 T, 90 M. (They are of a softer material and will wear rapidly against cast iron.)
3. The chrome plated ring used in the 90 STD, 90 T, 90 M cannot be used for the 90 Sport or 175 DT. Chrome will not operate properly against chrome.
4. Pistons made only for cast iron cylinders can be recognized by the small center drilled hole in the top of the piston.

5. Pistons made only for chrome plated aluminum cylinders can be recognized by the small flat spot on the top of the piston.
6. Pistons for the 90 Sport and 173 DT can be distinguished by the "T" stamped on the top of 173 pistons and no mark on 90 Sport pistons.
7. When installing new pistons or cylinders, the piston clearance should be checked and adjusted for proper operation. Check the piston clearance at the skirt of the piston and just above the ports in the cylinder.
 - Correct piston clearance for cast iron cylinders: .002 – .003 (50, 60 Spt), .0025 – .004 (90STD, T, M.)
 - Correct piston clearance for aluminum cylinders .0015 – .0025 (90SPT, 175DT)

On cast iron cylinders, the cylinder can be honed to adjust clearance.

On aluminum cylinders, the piston must be polished to adjust clearance. Pistons are identified on top of the pistons as follows:

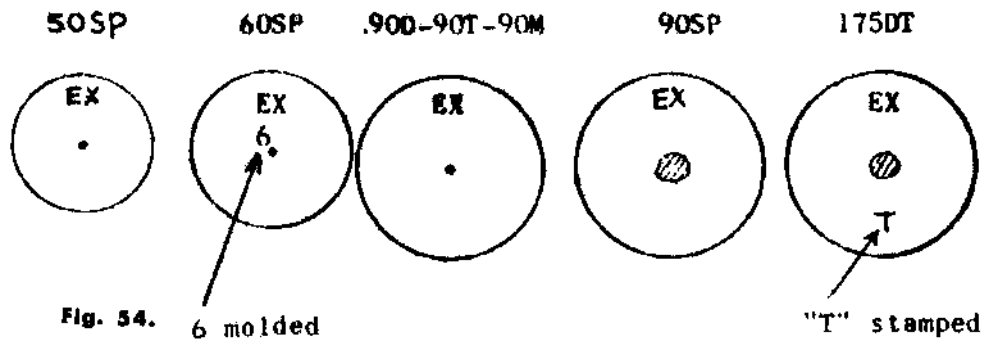

CRANKSHAFT AND ROTARY DISC VALVES

A. Construction and Operation

When the piston moves up and down in the cylinder from the force of the explosion of fuel/air mixture gas, the crankshaft converts this reciprocating movement to rotary motion and supplies power to the rear wheel through the clutch and transmission. The crankshaft must endure the impact of explosive force and the high temperatures of combustion.

Crankshaft strength and precision are required to endure continuous high speed operation for long times.

Crankshaft materials must be selected carefully and machined exactly to prevent twisting, cracking, offcentering, etc. The amount and direction, vertical or horizontal, of engine vibration has extreme affect on riding comfort and fatigue of the rider. The crankshaft is one source of vibration. If the crankshaft is not balanced properly, engine vibration will increase. Bridgestone crankshafts are designed to give smooth rotation and balanced operation with a minimum of vibration.

Rotary disc valves are installed between the carburetors and the crankcase and control the supply of fuel/air mixture from the carburetors to the crankcase. In conventional two-stroke engines, the fuel/air mixture is controlled by the skirt of the piston and port timing, the opening and closing of inlet and exhaust ports, is limited to before top dead center and after top dead center so that fuel mixture supply is not efficient.

By using a rotary disc valve, the best timing for engine operation can be determined by altering the cutaway of the valve disc, so that fuel supply and engine power are increased. Carburetor blow-back and fuel loss can also be eliminated and engine performance increased tremendously.

Fig. 55. Cross section of rotary disc valve engine

Fig. 56. Component parts of rotary disc valve

Fig. 55. Cross section of rotary disc valve engine

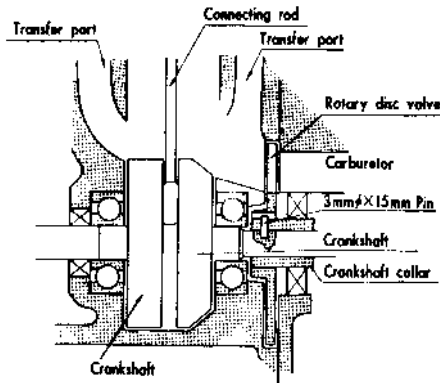
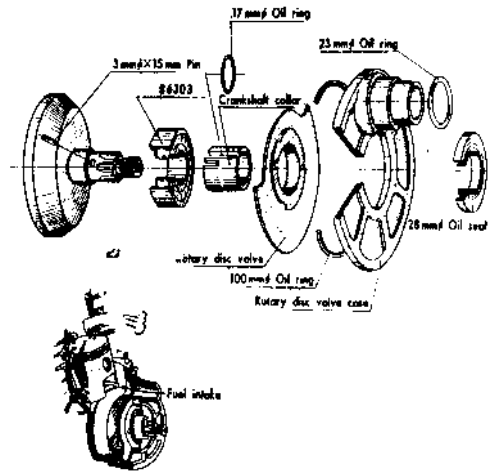

Fig. 56. Component parts of rotary disc valve



B. Rotary Valve Modification

The rotary valves were redesigned early in 1965 to eliminate the steel hub which was formerly molded into the valve disc.

The valve now fits onto a separate splined collar. Old style valves can be replaced by the new style valves by also installing the new splined collar and a new (shorter) crankshaft drive pin.

Fig. 57.

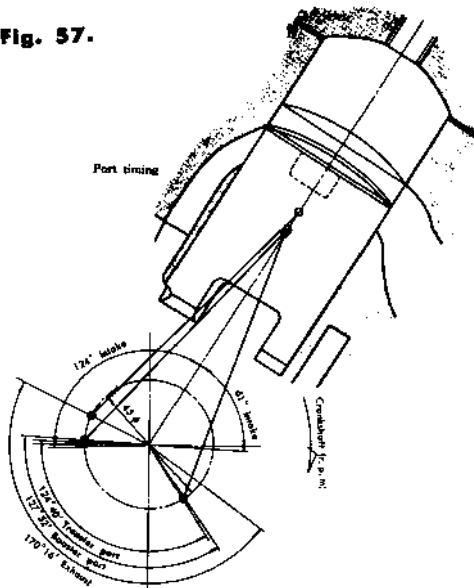
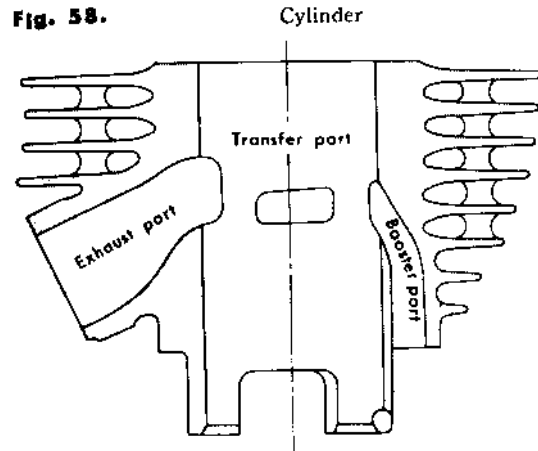

Fig. 58.



FOR 50-60 SPORT, 90 & 90 SPORT

Because of the new 2-piece design, valve timing must be aligned when installing a new style valve. The collar has a slot that is easily aligned on the pin in the crankshaft.

The rotary valve must be installed on the collar with the "dot" mark on the valve aligned with the "dot" mark on the collar.

Fig. 59.

Fig. 59.

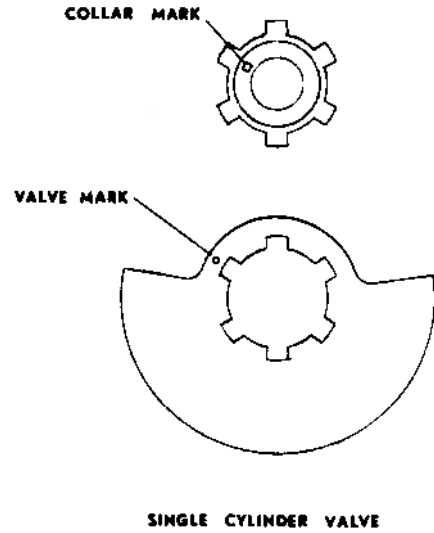

FOR THE 175 DUAL TWIN

The rotary valve used on the 175 Dual Twin is interchangeable for either left or right side and must be timed accordingly when installed. The valves are marked with an L and R.

The appropriate mark is aligned with the key slot in the crankshaft collar depending on whether the valve is being used on the Left or Right side of the engine.

Fig. 60.

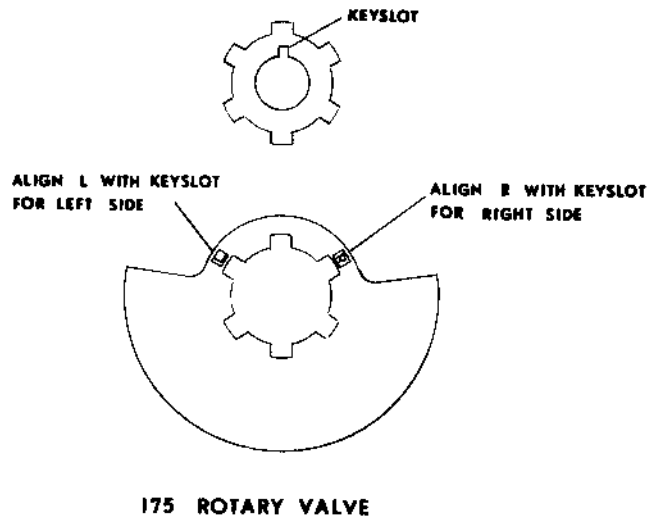

KICK STARTER MECHANISM:

Construction and Operation.

All Bridgestone rotary valve models are equipped with the primary kick starting system. In this method, the engine can be started in any gear by simply squeezing the clutch. This is possible because this system employs an extra set of gears for by-passing the clutch in starting the engine. This is a decided advantage since it is not necessary to seek out neutral gear in order to start the engine.

**50 Sport, 60 Sport and 90cc
KICK MECHANISM:**

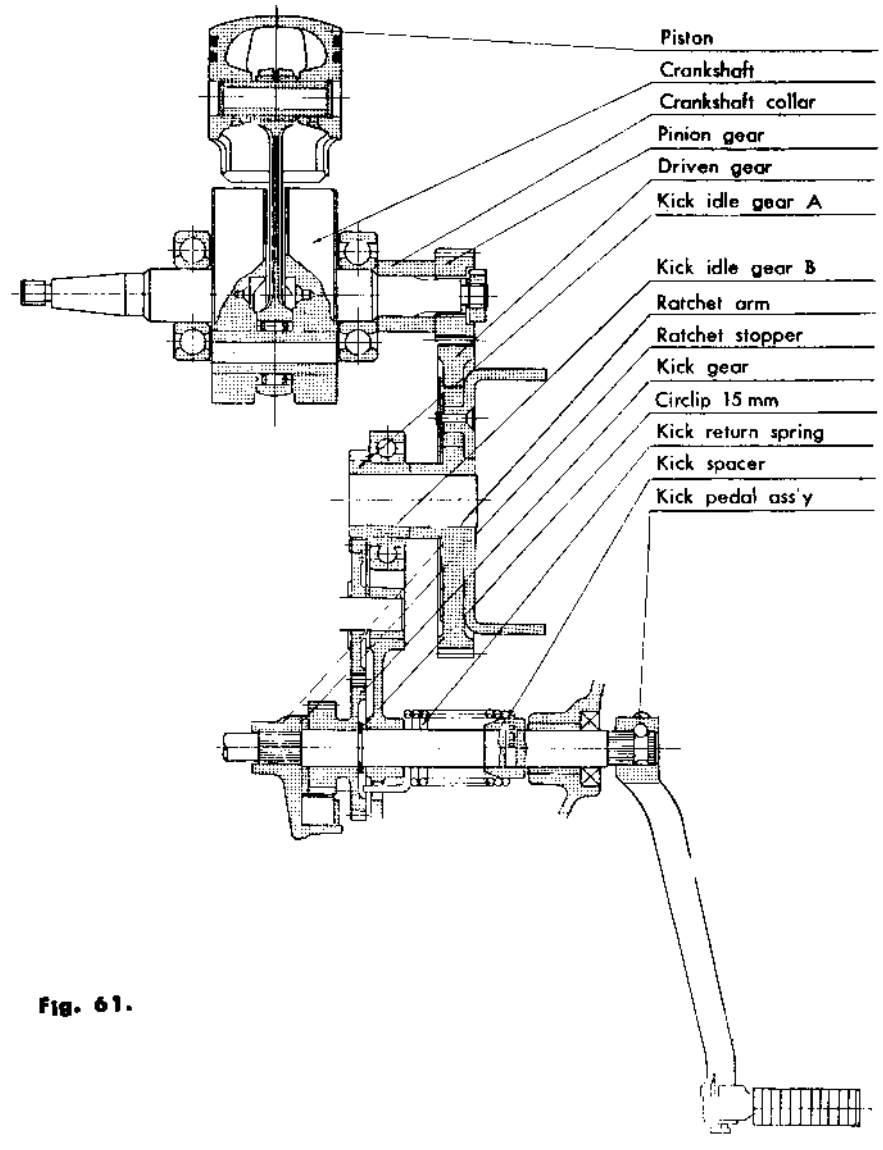

Fig. 61.

As shown in Figure 62, the kick idle gear A meshes with the driven gear, kick idle gear B meshes with kick idle gear A, and the kick gear meshes with kick idle gear B. Since the kick gear is always in mesh with kick idle gear B, the force created by turning the kick pedal is transmitted from kick gear, through kick idle gear B, kick idle gear A, driven gear and pinion gear, to the crankshaft and starts the engine.

175 DT

KICK MECHANISM:

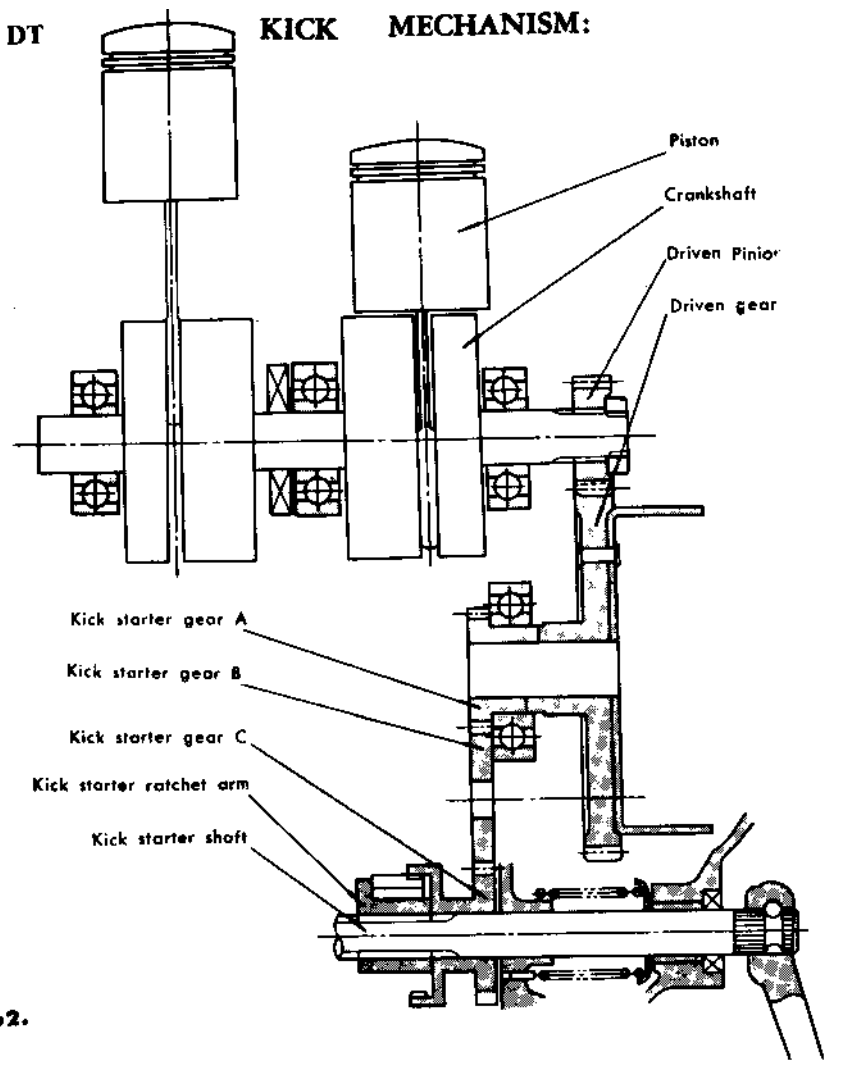

Fig. 62.

CLUTCH:

A. Construction:

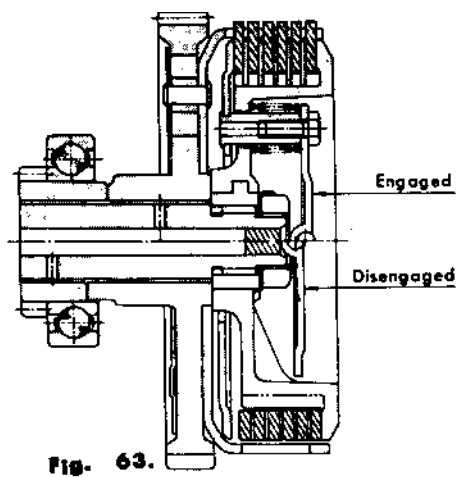

Fig. 63.

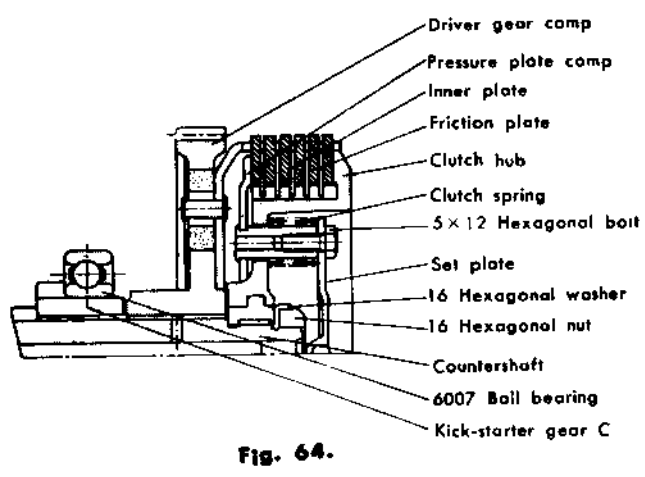

Fig. 64.

The clutch on all Bridgestone rotary disc models is a multiple disc type, running in oil. The clutch is mounted on the transmission countershaft. Clutch friction (fiber) plates are fitted inside the clutch housing with six teeth so that they turn with the clutch housing and driven gear. Clutch friction plates and inner plates are fitted alternately (steel plate first, then fibre plate, etc.) with the inner (steel) plates fitted to the clutch hub with teeth.

50, 60 Spt.	Clutch Friction Plate . .	3
	Inner Plate	3
	Clutch Springs	6
	Fitting Tension	110 inch lbs.

90 cc.	Clutch Friction Plate . .	5
	Inner Plate	5
	Clutch Springs	6
	Fitting Tension	120 inch lbs.

175 DT	Clutch Friction Plate . .	6
	Inner Plate	5
	Clutch Springs	6
	Fitting Tension	130 inch lbs.

B. Operation:

Located between the engine and transmission, the clutch transmits or cuts off engine power to the transmission and rear wheel.

Engine power is transmitted from the pinion gear on the crankshaft through the driven gear on the clutch housing. The clutch hub, friction plates and inner plates all fit inside the clutch housing. When pressed together by the clutch springs, the plates come into solid contact and rotate as a unit. The clutch hub is spline fitted to the transmission countershaft, which turns the transmission gears.

When the clutch lever is pulled, the clutch wire turns the clutch release arm so that the adjusting screw pushes the roller and depresses the clutch set (thrust) plate ball. The clutch springs are then compressed so that they do not press the clutch friction plates against the inner plates. As the friction plates and inner plates separate, the inner plates cease to turn so that engine power is cut off from the clutch hub and transmission countershaft.

In addition to transmitting engine power, the clutch has a large affect on riding comfort, so smooth operation of the clutch is necessary for comfortable riding.

If the clutch drags, gear shift operation becomes faulty and gears or the gear change arm can be damaged.

If clutch slips, poor acceleration, engine overheating, loss of engine power and uncomfortable riding will result.

C. Adjustment:

Correct clutch operation requires proper setting of both the clutch cable adjuster and the clutch adjusting screw which acts upon the clutch throw-out bearing.

Clutch cable adjustment should not be attempted without first removing the carburetor cover on the right side of the engine assembly. The cable adjustment determines the position of the clutch release arm and it is essential that the release arm is properly positioned to assure smooth clutch operation.

To adjust clutch:

1. Remove carburetor cover.
2. Turn cable adjuster until the release arm is positioned so that the center-to-center distance between the release arm pivot pin and the spring pin is 1 ¼" as shown in Fig. 65. (Screw cable adjuster in to shorten

the distance, out to increase the distance. When properly positioned, secure with cable adjuster lock nut.)

3. Loosen clutch adjusting screw lock nut and turn screw in (clockwise) until you feel it just touch the clutch throw-out bearing. Then turn screw out (counter-clockwise) $\frac{1}{4}$ turn.
4. Check clutch lever for correct free play ($\frac{3}{8}$ "- $\frac{5}{8}$ " at lever end). Turn adjusting screw as required for correct free play. (Counter-clockwise for more free play; clockwise for less.)
5. Secure adjusting screw in correct position with lock nut. **NOTE:** The tool kit shipped with the machine contains a special socket wrench with handle which fits adjusting screw lock nut. The design of this wrench enables you to hold clutch adjusting screw in correct position with a screw driver while securing the lock nut. This tool, incidentally, also serves as a screwdriver handle in cases where heavy pressure is required. See Fig. 66.

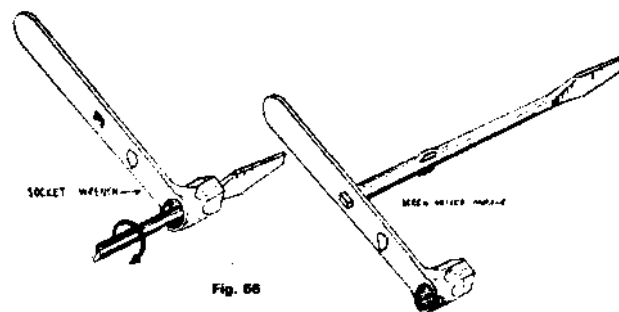
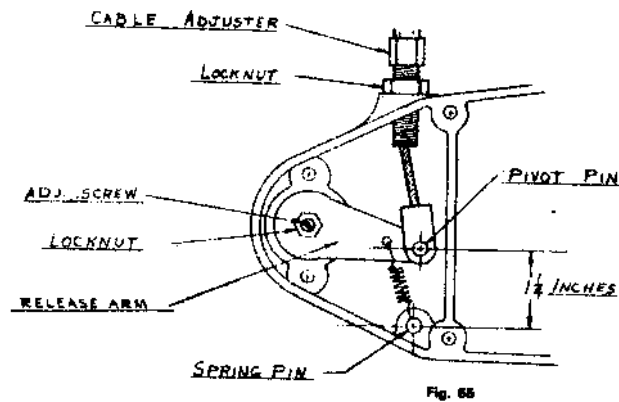

No further adjustment should be made on the cable adjuster unless it stretches with age. Periodic clutch adjustments should be made with the clutch adjusting screw only.

TRANSMISSION:

A. Construction and Operation (Fig. 67)

BS 50 60 Sport 90 cc

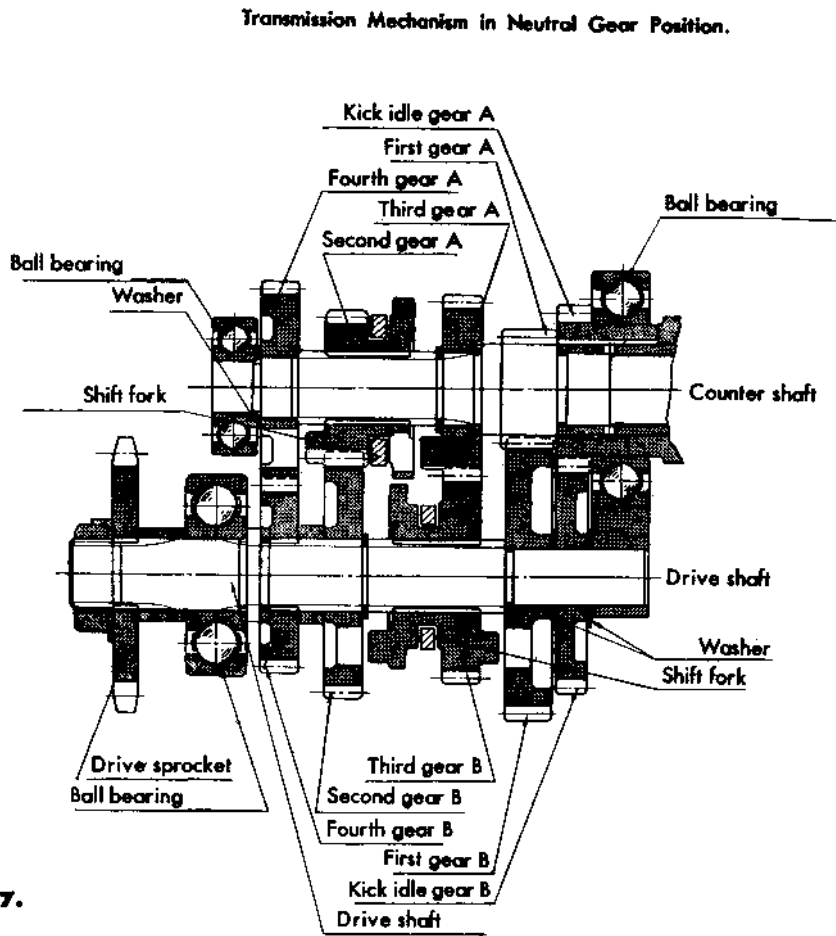

Transmission Mechanism in Neutral Gear Position.

The transmission in the rotary valve engines is of a constant mesh, rotary type, running in oil. In the 50, 60 Sport and 90 cc engines, the transmission is 4-speed. The 175 Dual Twin has a transmission which is both rotary change type 4-speed and a return change type 5-speed, made active by a simple flip of a lever.

The transmission consists of two shafts: the countershaft (or clutch shaft) and the drive shaft. The gears on the countershaft are referred to with the suffix letter "A", for example, "first gear A." The gears on the drive shaft are referred to with the suffix letter "B", for example, "first gear B."

First gear A is a part of the countershaft. Second gear A slides on the splined portion of the countershaft. Third gear A and fourth gear A rotate freely on the countershaft. These three spinning gears transmit power when they are engaged by drive dogs on the gears next to them. (Fifth gear A on 175 DT is keyed to the shaft.)

Fourth gear B and third gear B are fitted to the splined portion of the drive shaft and turn with the drive shaft. Second gear B, first gear B (and fifth gear B on 175 DT) turn freely on the drive shaft. Third gear B slides from side to side on the splined portion of the drive shaft and engages either first gear B or second gear B by means of the drive dogs on the sides of the gear.

The gears are so installed that the drive dogs on one gear engage the holes in the gear next to it. Gears are never installed with drive dogs facing each other. Also, the respective gears will fit only one shaft properly. Hence, all gears will mesh and drive dogs will properly engage the neighboring gears.

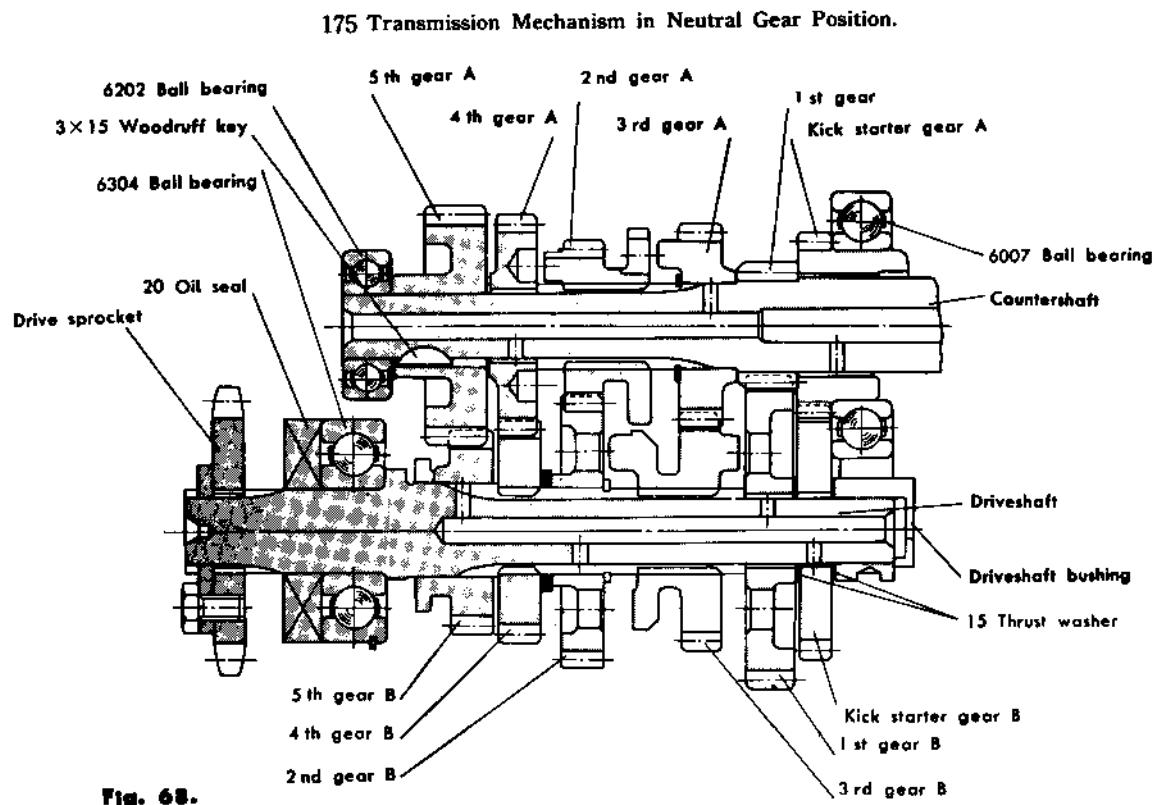

B. Gear Shift Mechanism

The Gear Shift Mechanism consists of a shift drum-shift fork assembly, shift drum pawl and shift arm assembly, drum stopper, gearshift shaft and shift pedal.

1. Shift drum-shift fork assembly.

The shift drum is cylindrical in shape and it has a spiral-like groove (two in 175DT) cut into its surface into which the shift forks are fitted. The rotary motion of the shift drum is translated into side-to-side motion in the shift forks as they move in the spiral groove. The shift forks, in turn, move the sliding transmission gears from side to side, thus shifting the various gears in the drive train.

2. Shift Drum Pawl.

The shift drum pawl is attached to the shift arm and serves to rotate the shift drum by means of pulling or pushing action on the shift pins attached to the end of the shift drum.

3. Drum Stopper.

The shift drum stopper holds the shift drum in position between gear shift operations by lodging between the drum shift pins.

4. Gearshift shaft.

The gear shift shaft serves to connect the shift arm and shift pawl to the footoperated gearshift lever.

5. Gearshift Lever.

The gearshift lever is located on the left side of the cycle and is foot-operated. Each time the front of the lever is depressed or lifted, the transmission is shifted either one gear up or down, respectively.

Pedal pushed down front with foot once showing drum advanced one notch, (engaging 1st gear) 2nd, 3rd, 4th and Neutral follow in succession.

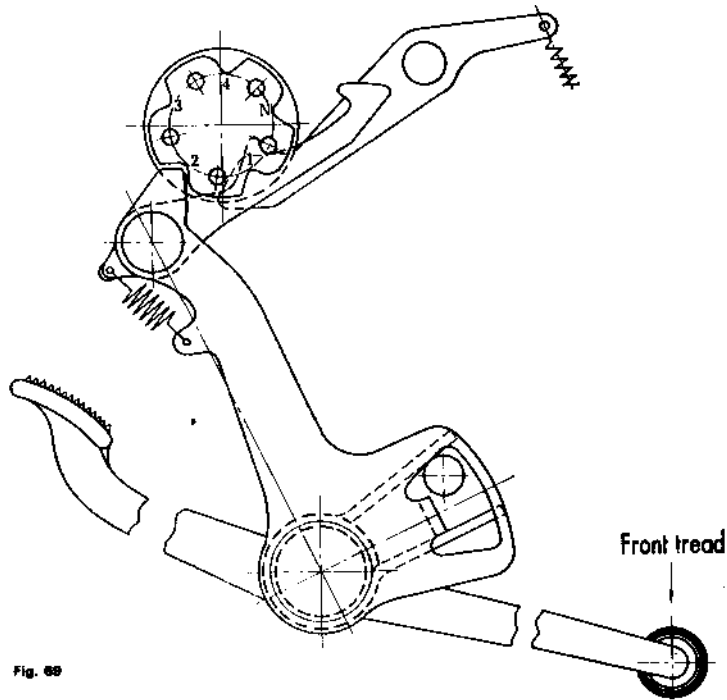

Back pedal tread pushed down with foot once showing drum turned in the opposite direction and shifting gear in reverse.

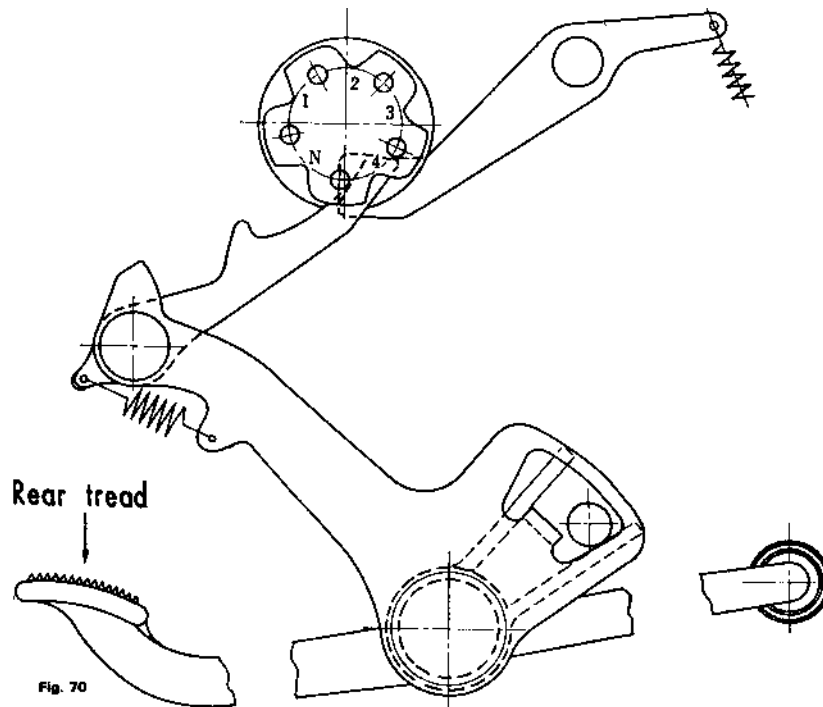

C. Gear Shift Operation:

The rotary valve engines are equipped with rotary-type shift mechanisms. Each time the shift pedal is depressed with the toe, the transmission shifts one gear higher. Starting in neutral, if the pedal were depressed and released 3 times, the transmission would shift from 1st to 2nd to 3rd to 4th and back to neutral. Fig. 71. Depressing the rear portion of the pedal with the heel shifts the transmission down one gear lower each time it is depressed.

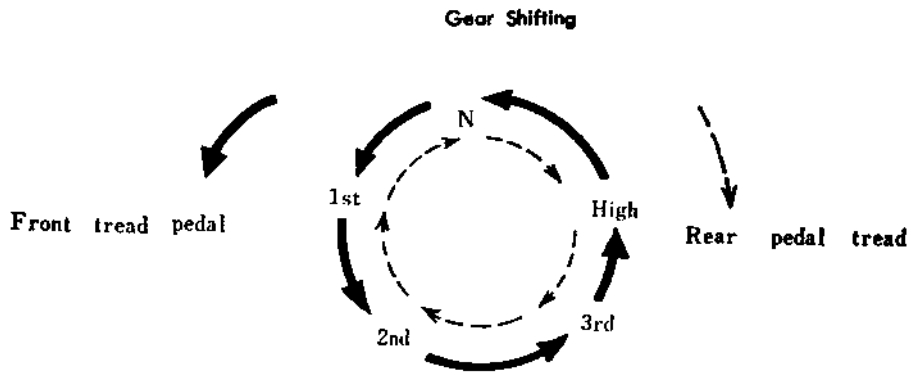

Fig. 71

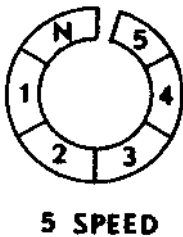

Fig. 72

The transmission in the 175 Dual Twin can easily be switched from the rotary change type four speed (described above) to the return change type five speed with overdrive (left) by simply moving a sportshift lever. (NOTE: This sportshift can be moved while in any gear except neutral.) The gear change system components are installed in the left crankcase cover so that maintenance, disassembling and inspection are easy.

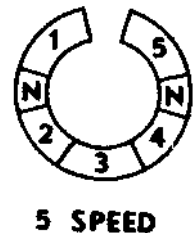

Fig. 73

Bridgestone 175's manufactured before November, 1965, (Serial No. 16W02913) were equipped with the old style shift drum on which there were two neutral positions. As illustrated above right, one neutral was positioned between 1st and 2nd gear, the other between 4th and 5th gears.

Fifth gear B is put into play by putting the "Sportshift" lever in the 5-speed position and depressing the shift pedal. Turning the lever positions the guide pin in the 5th speed shift drum groove, thus connecting the 5th gear shift fork to the shift drum. When the shift pedal is depressed, the drive dogs on 5th gear B (a free spinning gear) engage the drive dogs on the drive shaft, thus transferring power from 5th gear A, which is keyed to the clutch shaft, to the drive shaft.

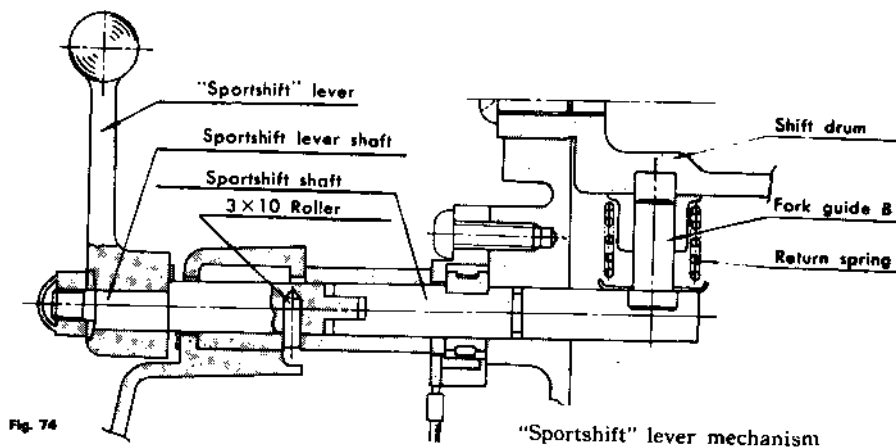

Fig. 74

The fifth speed shift fork on B/S 175 has been modified after serial No. I6B04739. The changes include a guide pin in the crankcase, a new shift fork and 5th gear B. The new shift fork and gear are interchangeable in sets only. When installed in old style crankcase, the shift fork is not connected to a pin.

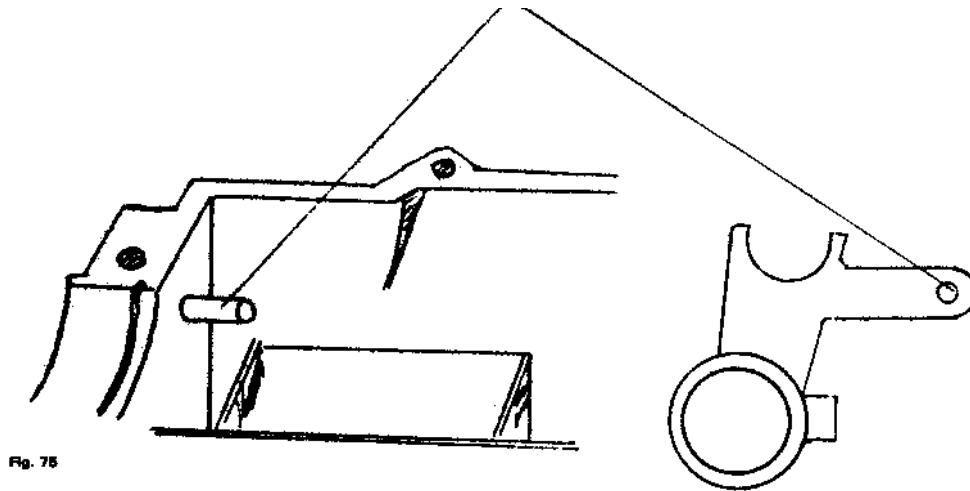

Fig. 75

First Gear:

With the First Gear A on the countershaft remaining in position, the Third Gear B on the driveshaft slides to the right and the claws engage with the First Gear B.

Engine power is transmitted in the order of driven gear-clutch-countershaft-First Gear A-First Gear B-Third Gear B-driveshaft and drive sprocket.

50, 60 Spt. 90 cc.

In First Gear Position.

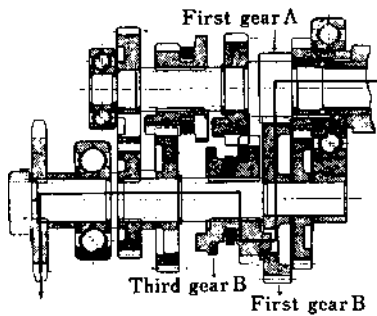

Fig. 76

175 DT

In First Gear Position

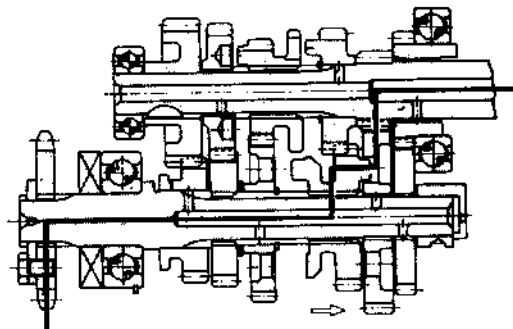

Fig. 78

Second Gear:

50, 60 Spt. 90 cc.

175 DT

In Second Gear Position.

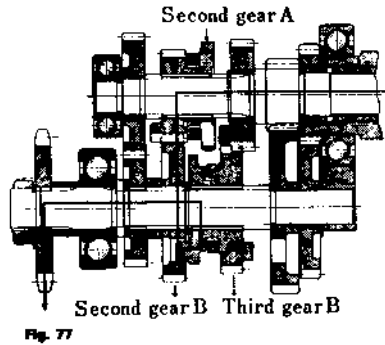

In Second Gear Position

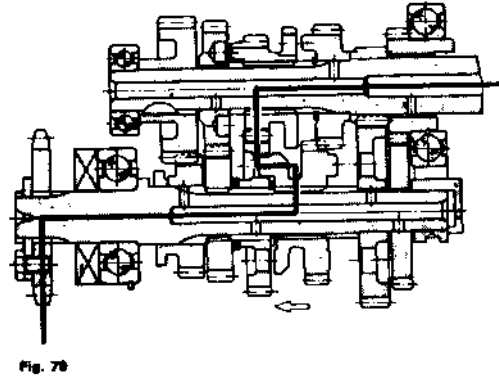

The second Gear A remaining in position, the Third Gear B slides to the left and the claws on this gear engage with the Second Gear B.

The engine power is transmitted in the order of driven gear-clutch-countershaft-Second Gear A-Second Gear B-Third Gear B-driveshaft and drive sprocket.

50, 60 Spt. 90 cc.

175 DT

In Third Gear Position

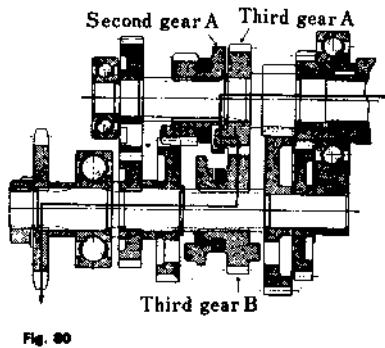

In Third Gear Position

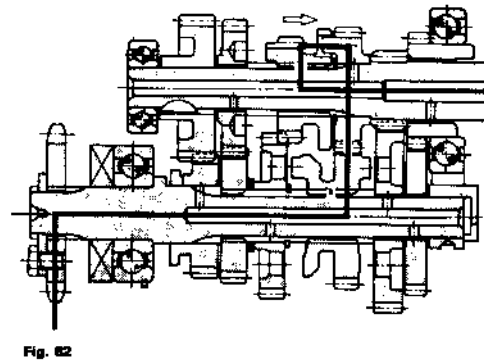

Third Gear:

With the Third Gear B on the drive shaft remaining in position, the Second Gear A slides to the right and engages with the claws on the Third Gear A.

The engine power is transmitted in the order of driven gear – clutch – countershaft – Second Gear A – Third Gear A – Third Gear B – driveshaft and drive sprocket.

In Fourth Gear Position.

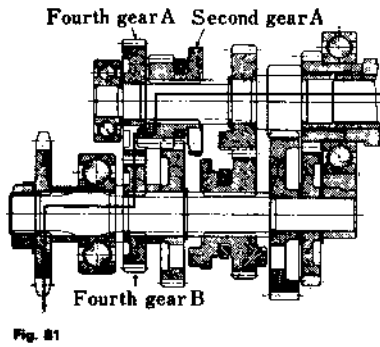

In Fourth Gear Position

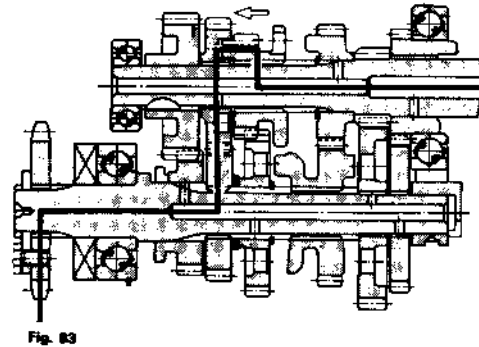

Fourth Gear:

The third Gear B remaining in position, the Second Gear A slides to the left and the dog teeth engage with the Fourth Gear A.

The engine power is transmitted in the order of driven gear-clutch-countershaft-Second Gear A-Fourth Gear A-Fourth Gear B-driveshaft and drive sprocket.

175 DT

In Fifth Gear Position

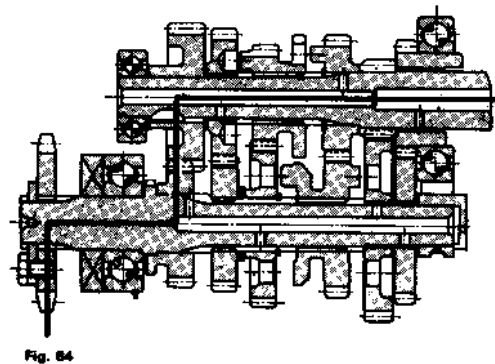

Fifth Gear:

The Fifth Gear is engaged with driveshaft by shifting "Sportshift" lever.

D. Gear Ratios:

	Gear	Number of Teeth		Transmission Gear Ratio
		Countershaft	Drive Shaft	
50,60 Spt. 90 cc 175 DT	1 st	13	38	2.92
		13	36	2.77
		13	34	2.61
	2 nd	18	33	1.83
		18	31	1.72
		18	30	1.67
	3 rd	22	29	1.32
		22	27	1.23
		21	26	1.24
	4 th	26	26	1.00
		26	24	0.924
		24	24	1.00
175 DT	5 th	26	22	0.85

CARBURETOR:

A. Construction and Operation:

The Bridgestone rotary valve models are equipped with Amal-type carburetors, i.e. those which control both the fuel and air flow. The air passing through the air cleaner enters the carburetor venturi. The vacuum created in the venturi by this flow of air causes the fuel in the float chamber to be drawn through the main jet, needle jet and then through the passage to the fuel inlet port. This fuel is mixed with air entering through the venturi. The fuel has been atomized by the air entering through the air jet. Carburetors are classified according to the size of the venturi. The 50, 60 Sport models and the 90cc series (except the 90 Sport) utilize the 15mm carburetor. The 90 Sport and the 175 DT are equipped with 17mm carburetors. Because two carburetors supply a mixture of fuel and air to the 175 DT engine, it is important that both carburetors are synchronized so that equal performance is obtained.

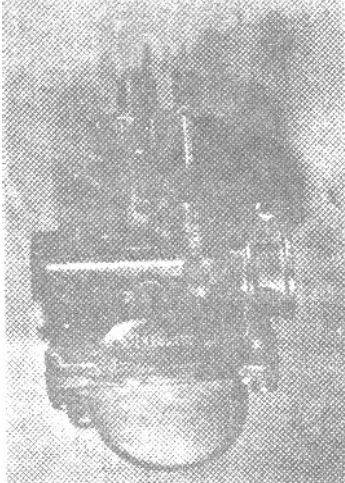

Fig. 85

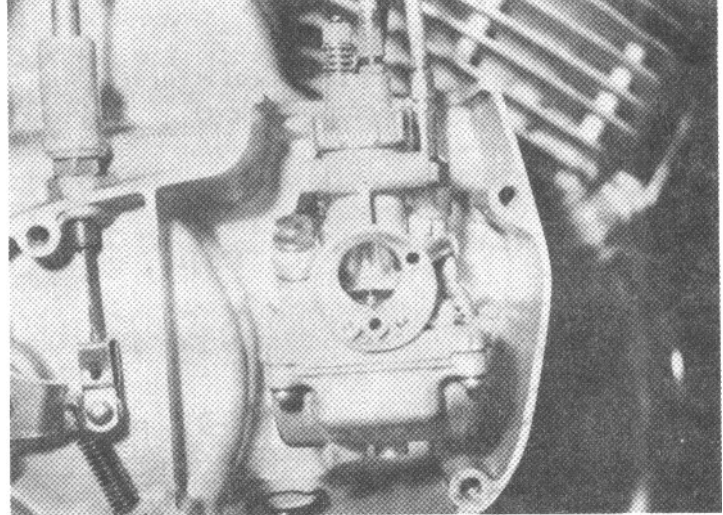

Fig. 86

Different parts of the carburetor control the fuel/air mixture for starting and for low speeds, medium and high speeds. Instructions for each follow:

(1) Starter System

When the carburetor starter lever on the handlebar is pushed, the starter plunger is raised by the starter wire.

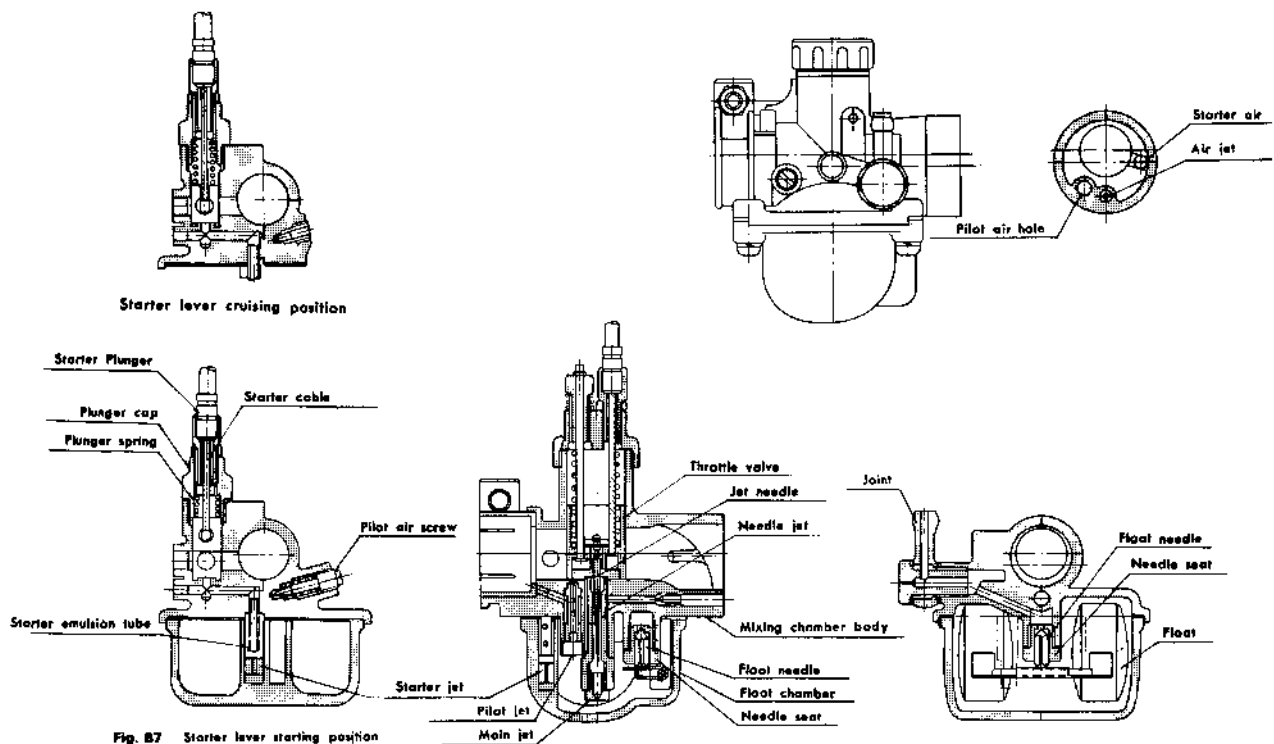

Fig. B7 Starter lever starting position

When the kick starter lever is depressed with the throttle valve closed, air induction is generated behind the throttle valve by the engine suction. This condition is similar to that created when the choke of a conventional carburetor is fully closed. As the throttle valve is closed, air is inhaled only through the starter air channel. Strong air induction is generated at the fuel jet located at the narrow starter plunger. Fuel in the float chamber is metered by the starter jet and moves up the emulsion tube. Air is inhaled from the wall of the tube and a rich mixture of air and gasoline is made. When secondary air is added to this mixture, a correct rich mixture for starting a cold engine is inhaled into the engine through the nozzle located behind the main bore.

NOTE: It is most important that the throttle valve be left closed when starting the engine. If it is not, the rich gasoline/air mixture will be leaned out. Too, the raising of the throttle valve hampers the inhalation of this correct mixture by taking away the vacuum ordinarily created when the kick starter is depressed.

(2) Slow channel (mainly for idling)

The suction stroke of the piston induces air at the pilot outlet of the carburetor so that gasoline is metered through the pilot jet and air is drawn through the pilot air hole and metered by the air adjusting screw. The gasoline and air make a rich fuel mixture which jets from the pilot outlet into the main bore where it mixes with a small amount of air and is supplied to the engine, along with a correct amount of oil injected into the intake between the carburetor and the engine.

(3) Main Channel (mainly for medium and high speeds)

Air entering the carburetor from the air cleaner passes under the throttle valve and is inhaled into the engine as the main air flow. Induction is created at the needle jet by this main air flow and gasoline in the float chamber is metered by the main jet and enters the needle jet. This gasoline passes through the gap between the needle jet and jet needle and flows into the main bore of the carburetor. The gap between the needle jet and the jet needle is controlled by the throttle grip, so that when it is opened the gap increases and the flow of gasoline increases and when it is closed the gap decreases and the flow of gasoline also decreases.

Air which enters through the air jet mixes with the gasoline from the main jet in the needle jet and it is atomized when mixed with the main air flow and flows into the engine.

(4) Float Chamber

The carburetor makes a proper gasoline/air mixture according to the throttle opening and engine speed. To create this proper gasoline/air mixture, the supply of gasoline must remain constant. The float chamber supplies a constant flow of gasoline to the carburetor.

Gasoline flows from the tank through the pipe to the carburetor banjo bolt and between the valve seat and valve to enter the float chamber. When gasoline enters the float chamber, the float moves up to stay on top of the gasoline and pushes the valve closed with the valve arm. When the valve touches the valve seat, the flow of gasoline stops. When gasoline in the float chamber is consumed and the level lowers, the float moves down and the float arm no longer presses against the valve, allowing it to move away from the valve seat and gasoline to enter the float chamber between the valve and valve seat. These procedures are repeated and a constant level of gasoline is kept in the float chamber.

B. Functions of Various Parts:

(1) Main Jet

The main jet controls the fuel supply when the throttle is more than threequarters open, but at smaller throttle openings although the fuel passes through the main jet the amount is diminished by the tapered needle jet. Listed below are the carburetor main jet sizes that are used as standard equipment on the Bridgestone rotary valve models. Also listed are other sizes that are available.

Main Jet.

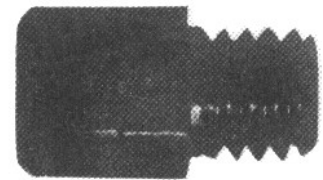

Fig. 88

MODEL	ORIGINAL EQUIPMENT	AVAILABLE
	Main jet number	
15mm Carburetor	110	100
56-60 Sport	100	
90 before 12N	130	
90 12N and after	120	
90 Trail	130	
90 Mountain	130	
17mm Carburetor		
90 Sp before 14L	95	Set of 5 (110-150)
90 Sp 14L and after	100	Set of 5 (110-150)
175DT	100	Set of 5 (110-150)

(2) Air Jet

The air jet controls the flow of air entering the needle jet. The fuel passing through the needle jet mixes with the air coming in from the air jet.

(3) Needle Jet

At full throttle or at medium speeds, the fuel is first regulated by the main jet and the needle jet acting simultaneously.

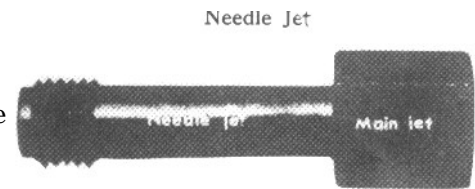

Fig. 90

(4) Jet Needle

The tapered jet needle attached to the throttle valve works in the needle jet and adjusts the air/fuel ratio at medium ($\frac{1}{4}$ to $\frac{3}{4}$) throttle openings.

Jet Needle

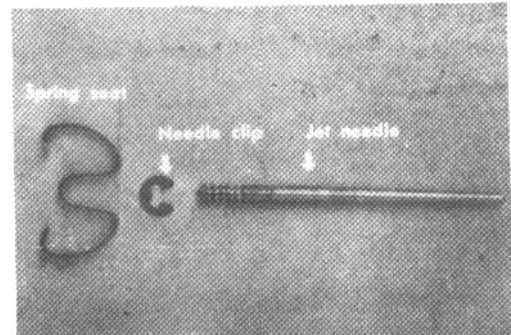
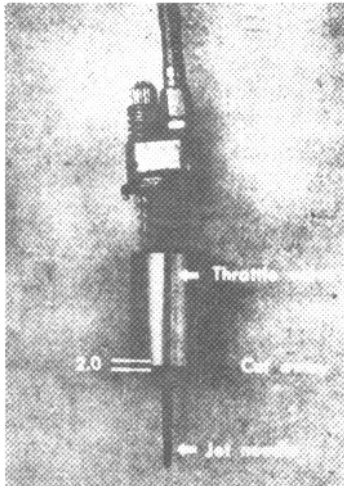

Fig. 91

Throttle Valve

(5) Throttle Valve



The throttle valve is cut away on the inlet side and controls the flow of main fuel supply from $\frac{1}{4}$ to $\frac{3}{4}$ throttle opening. The extent of cut away is marked on the valve, viz. 2.0 for 2.0mm cut away.

Fig. 92

(6) Pilot Jet

At idling speed or small throttle openings, the pilot jet controls the flow of fuel mixed with air which enters through the air jet, and atomizes the mixture.

(7) Air Screw

The air screw controls the flow of air which mixes with the fuel passing through the pilot jet.

The standard adjustment of this screw position for the various models is stated below under Adjustment (3).

Pilot Jet

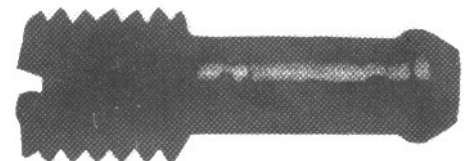

Fig. 93

C. Adjustment:

Carburetors on all models are factory adjusted for proper operation and idle. In the event idle adjustment is necessary, proceed as follows:

Air Screw

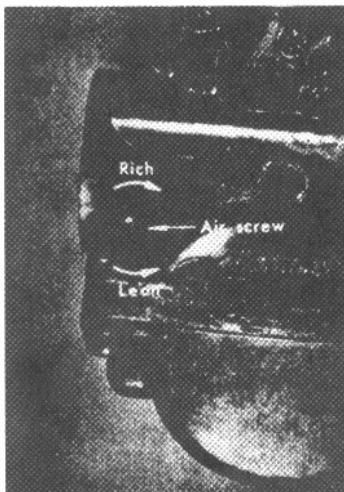

Fig. 94

- (1) Run engine for at least 3 minutes in a properly ventilated area. Idle cannot be correctly adjusted on a cold engine.
- (2) Turn idle mixture adjusting screw in clockwise as far as it will go.
CAUTION: DO NOT OVER-TIGHTEN!
- (3) Turn idle mixture adjusting screw counter-clockwise the number of turns indicated below:

MODEL ADJUSTMENT

BS 50-60 Sport	1 3/4 turns
BS 90STD, 90D, 90T, 90M	1 3/4 turns
BS 90 Sport	1 1/2 turns
BS 175 DT	1 1/2 turns

(4) With the engine running, adjust idle speed with idle speed adjusting screw to the lowest RPM possible without stalling engine.

(5) Turn idle mixture screw 1/2 turn in either direction until point is found where idle RPM is highest.

(6) Re-adjust idle speed screw for best idle speed.

TO ADJUST FLOAT LEVEL:

- (1) Remove float bowl cover.
- (2) Remove float bowl cover gasket.
- (3) Holding carburetor upside down (float valve closed) measure distance between gasket seat and top of float with a vernier scale. Correct distances are as follows:

MODEL FLOAT LEVEL SETTING

BS 30-60 Sport	25/32 inch
BS 90STD, 90D, 90T, 90M	25/32 inch
BS 90 Sport	23/32 inch
BS 175 DT	23/32 inch

(4) Make adjustments in float level by bending only the brass tab which acts upon float level. On dual float carburetors, make certain both floats are equal before setting the float level.

Medium Engine Speeds Adjustment:

The gasoline/air mixture can be adjusted by raising or lowering the jet needle at C - 3/4 throttle openings for medium engine speeds. Standard setting is in the third groove from the top. The throttle valve cutaway also affects engine operation at below C throttle opening, so do not change throttle valve cutaway for only medium speeds adjustment.

It is recommended to raise or lower the jet needle for medium engine speeds adjustment within the range where acceleration is not adversely affected.

High Engine Speeds Adjustment:

The performance of the engine between 3/4 and full throttle can be adjusted by changing the main jet. A higher numbered jet provides a larger orifice and, conversely, a smaller numbered jet provides a smaller orifice. The jet number appears stamped on the side of the jet.

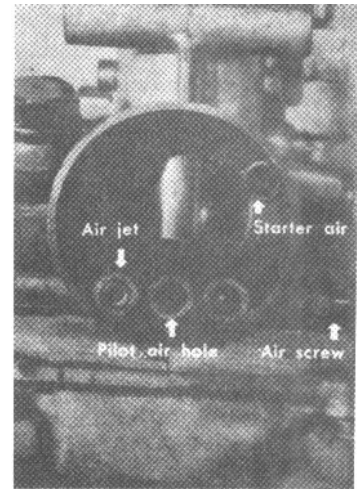

Fig. 89

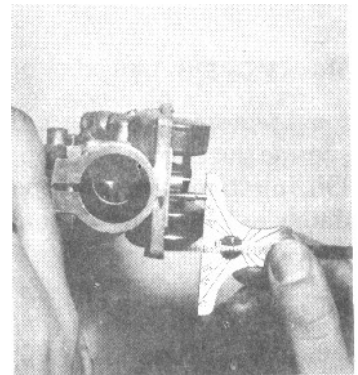

Fig. 94a

OIL INJECTION SYSTEM – 90cc

In the conventional two-stroke engine, a fuel mixture of gasoline and lubricating oil is used so that parts inside the engine are lubricated by oil contained in the fuel mixture. In the Bridgestone Oil Injection System, a premixed fuel is not necessary; gasoline and oil are supplied separately to the engine. Gasoline is supplied through a carburetor as in the conventional system.

A. Construction and Operation:

The oil injection pump is installed in the transmission case.

The pump works as follows:

The worm wheel of the pump is driven through:
Crank shaft – Drive pinion – Pump Gear B

The worm wheel, the boss of which is cam-shaped, is in addition to being rotated by the pump drive shaft, pushed in direction B by the plunger spring and contacts the rod (c) as shown in Fig. 96. The worm wheel plunger slides in the direction of (a) or (b) shown by arrows in Fig. 96 and 98, following the cam height.

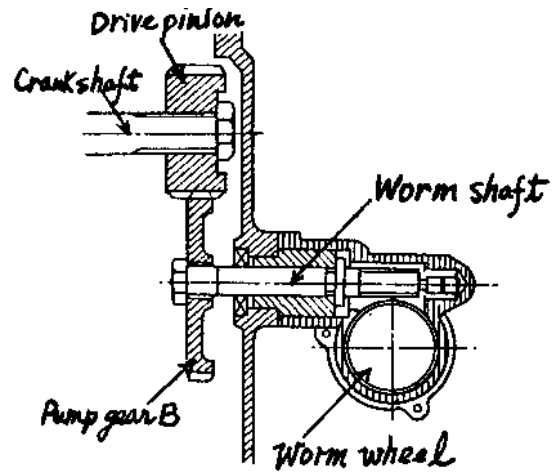

Fig. 96

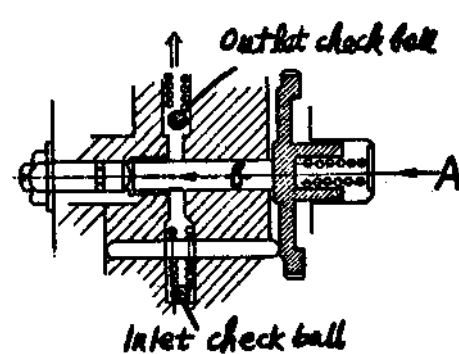

Fig. 98

1. Oil Intake:

When the worm wheel contacts the rod (c) at the highest point of the cam, the volume of the pump chamber increases and the pressure in the chamber (Fig. 99) decreases and releases the inlet check ball. The inlet port opens and oil is sucked into the oil pump chamber.

2. Oil Outlet:

When the worm wheel plunger slides in the direction (b) illustrated by the arrow in Fig. 98 the volume of the pump chamber decreases. By decreasing the volume of pump chamber, the inlet check ball closes the inlet port and the outlet check ball opens the outlet port.

Oil is forced into the crankcase.

3. Operation of Worm Wheel Plunger in Relation to Throttle Grip:

(a) Slow speed—idling:

When the throttle grip is in zero position, i.e. throttle grip is in closed position, the rod (c) contacts the control lever at its lowest position. The worm wheel plunger slides to the left (arrow "a") and the plunger contacts the adjusting screw as shown in Fig. 98. The distance of shift of the plunger to the adjusting screw (d) is shortened to less than the height of the worm wheel cam, thereby reducing the volume of oil.

(b) High speed — wide open throttle:

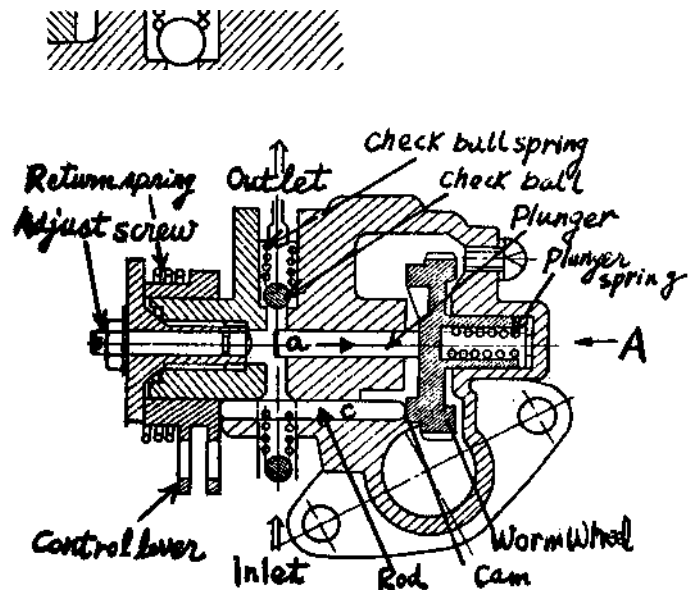

Fig. 99

When the throttle grip is wide open, the cam of the control lever contacts the rod (c) at its highest point, thereby shifting the rod (c) to the right (arrow A).

The distance of shift of the plunger is lengthened, and the volume of oil increased.

B. Adjustment:

The oil pumps used on B/S 90 machines are factory adjusted for the proper amount of oil and should never need adjusting. The only time adjusting should be necessary is when a customer or an unauthorized personnel may have tampered with the adjustment.

If the setting needs adjusting, proceed as follows:

Note: Use extreme care when making this adjustment and follow these instructions exactly.

TO REMOVE AND DISASSEMBLE THE PUMP

- Remove the 2 pump mounting screws.
- Disconnect the pump control cable from the control arm.
- Disconnect the inlet and outlet oil lines from the pump. Caution: Care must be used not to lose the balls and springs from the connecting bolts.
- Remove the pump from the engine.
- Disassemble the pump by removing 3 pump housing screws and separate the two pump halves.
Caution: Locate the spring in the end of the pump gear so that it does not become lost.

TO ADJUST THE PUMP

1. Hold the pump in the position shown below and revolve the pump gear so that the highest point of its earned edge "A" is in contact with the stop pin "B".
2. Loosen the adjusting screw lock nut "C"
3. Turn the adjusting screw "D" in (clockwise) until it pushes the pump gear out just to the point where the stop pin "B" is just contacting the high point of the cam "A". Check by revolving the pump gear while holding it in against the adjusting screw, to see that the gear does not move in and out when it moves from the high to the low point of the cam. The stop pin "B" should just touch the high point of the cam when it is revolved.
4. When the screw "D" has been set so that the stop pin "B" is just touching the high point of the cam, turn the adjusting screw "D" out (counterclockwise) *exactly* $\frac{3}{4}$ of a turn and secure with the locknut "C".

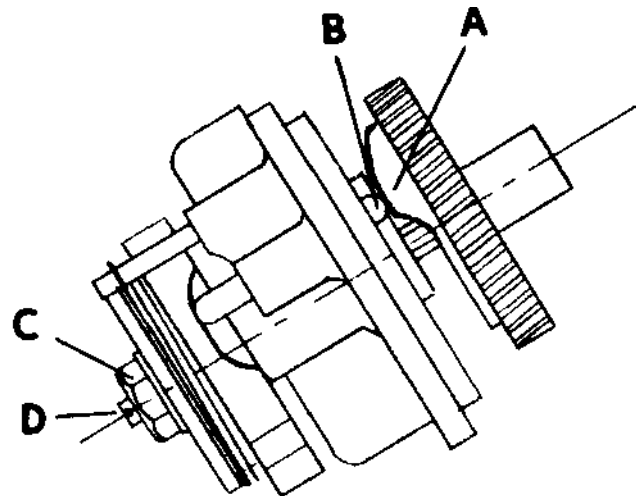

Fig. 103

The pump is now correctly adjusted for all driving speeds.

TO REASSEMBLE THE PUMP

1. Install the gear spring into the pump gear.

2. Assemble the gear case gasket and housing in place and reinstall 3 screws, fastening securely.
3. Place a small quantity of oil in the gear case housing and reassemble the pump onto the engine, but do not install the mounting screws.
4. Reconnect the inlet and outlet oil lines.

(a) The brass connecting bolt and spring must be used on the inlet line.

- The spring must be installed first into the pump and then the check ball.
- **NOTE: Only a brass connector bolt can be used in this port.**

(b) The steel connecting bolt and spring must be used only on the outlet line.

- The check ball is installed first into the pump and then the spring.

- **NOTE: Only a steel connector bolt can be used in this port.**

5. When assembling the oil line onto the rotary valve cover, a steel connector bolt must be used.

6. Do not over tighten the connecting bolts.

7. Install the 2 pump mounting screws and tighten securely.

8. Connect the control cable to the pump and check its adjustment.

- With the throttle completely closed, the oil pump outer cable should have 1/16 of an inch of free play at the oil pump cable stop pin. Adjustment is made by the cable adjuster located in the cable by the transmission oil filter plug.

9. If, after adjusting the pump according to the above instructions, it appears that it is pumping too much oil, without removing the pump, loosen lock nut "C" and turn the adjusting screw "D" clockwise a slight amount. Never adjust more than **C** turn at a time until the cycle is operated and again check..

C. Special Attention to the Oil Injection System:

The following procedures are necessary after filling up the oil tank before break-in or after disassembling oil tank or pump.

1. Remove the carburetor cover by screwing out the 4 carburetor cover screws.
2. The oil inlet tube (black) and the oil tube (transparent), which are connected to the oil pump, are shown in Fig. 109
3. The oil outlet tube (transparent) is connected to the rotary valve cover.
 - Procedures 4 and 5 are necessary to exhaust any air bubbles from the rotary valve cover, and obtain free flow of oil from the pump to the outlet tube.
4. Loosen the oil inlet union bolt one or two turns, (do not take out this bolt) and pump oil out from the union bolt on oil tube (black) connecting oil tank and oil pump, by pinching the oil tube alternately with fingers of both hands as shown in Fig. 109

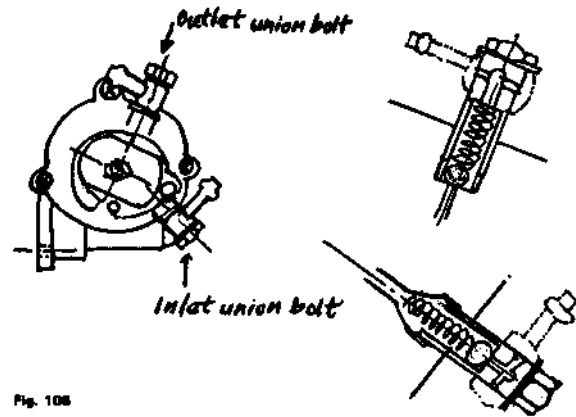

Fig. 108

- NOTE: Pinch part A first, then pinch part B; repeat alternately until air bubbles are eliminated and the oil flows freely out of the union bolt.

5. Tighten the oil inlet union bolt and repeat pinching with fingers; check the oil flow in the outlet tube (transparent) to the inlet in the rotary valve cover.

- If there is no oil flow in the outlet tube (transparent), repeat procedure 4.

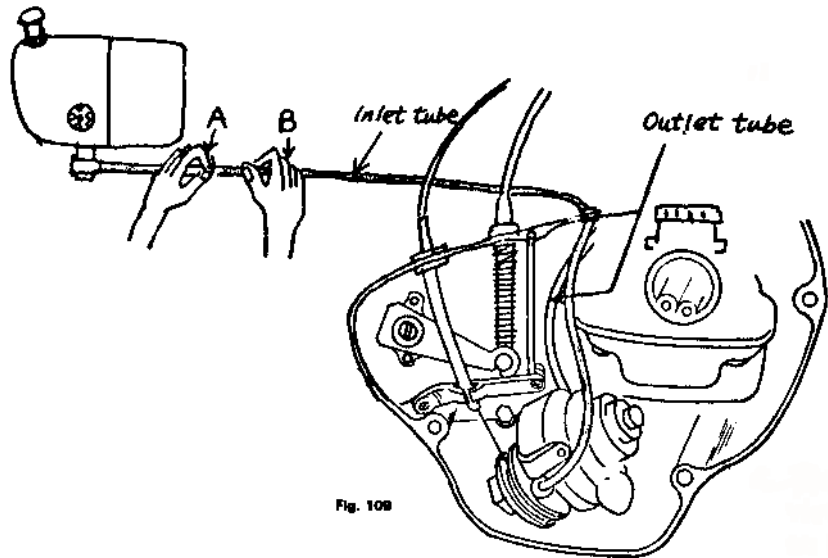

Fig. 100

A simple check of the oil injection system can prevent serious damage when the machine is operated. Dirty or plugged oil lines, tanks, or filter could prevent the oil flow from the oil tank to the pump.

Whenever a new cycle is serviced, the oil supply line to the pump should be removed at the pump and checked for oil flow.

If a good supply of oil is not available at this line, check the tank, filter and lines and correct as necessary. Oil must flow freely from this line to supply the engine with the proper lubrication.

OIL INJECTION SYSTEM – 175DT

A. Construction and Operation:

Lubricating oil is supplied by an oil pump attached to the left rotary valve cover. Oil pump gear B, attached to the pump drive shaft, is driven by gear A, located on the left end of the crankshaft.

The oil pump Drive Shaft drives the pump plunger through a worm gear arrangement. The speed at which the Plunger rotates, then, is determined by crankshaft RPM. There is a 12:1 reduction in the gearing between the crankshaft and the pump drive shaft.

In addition to being rotated by the pump drive shaft, the Plunger moves up and down in the pump body. This

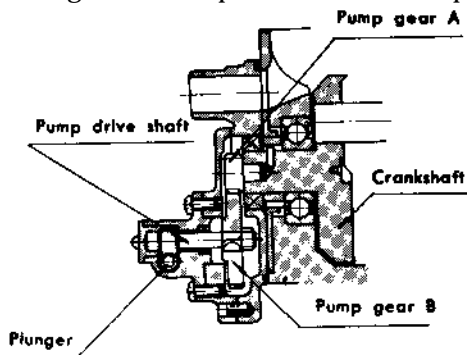

Fig. 101

reciprocating motion is produced by the cam-shaped lower end of the Plunger bearing against the Plunger Guide.

The Plunger is held against the Plunger guide by the spring-loaded Differential Plunger which bears against the top of the Plunger. The length of the Plunger stroke is determined by the position of the Stop cam in the lower end of the Pump Body. The stop cam is part of the control arm assembly which is connected by means of a control cable to the throttle grip.

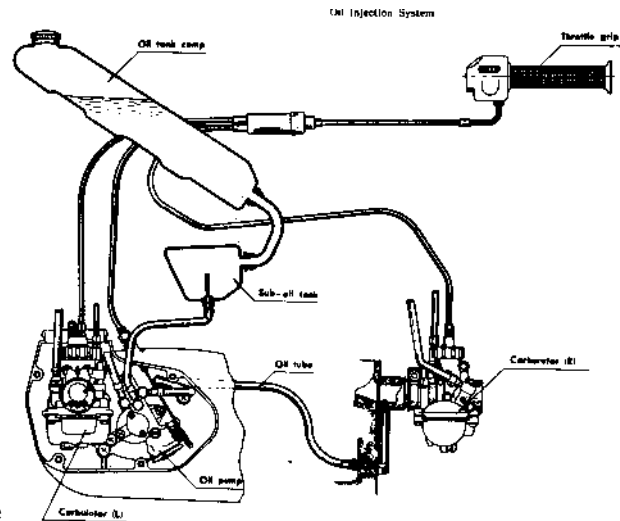

Fig. 97

When the throttle is closed, the lobe of the stop cam limits the down stroke of the Plunger resulting in a short stroke. This short stroke of the Plunger reduces the amount of oil pumped at idle.

As the throttle is opened, the Control Arm rotates the eccentric Stop Cam so that the length of the Plunger's stroke is progressively increased, resulting in an increased volume of oil being pumped to the injectors.

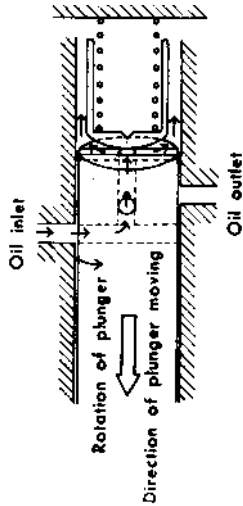

Fig. 102

OIL INTAKE

The diameter of the Plunger is slightly larger than the diameter of the Differential Plunger. The pumping action takes place in the area surrounding the Differential Plunger in the oil pump body.

As the plunger moves downward in the pump body, this area is increased in volume and a partial vacuum is produced. The rotation of the plunger (as it moves downward in the pump body) allows the inlet hole in the plunger to align itself with the Oil Inlet leading from the supply tank. This is drawn up through the Plunger and out the hole in its top and into the areas surrounding the Differential Plunger.

OIL DISCHARGE

When the rotating Plunger moves UP in the oil pump body, the area surrounding the Differential Plunger is decreased in size and the compressed oil re-enters the hole in the top of the plunger and is discharged through the left or right oil outlet. The rotation of the Plunger has aligned the oil outlet port in the Plunger with an oil outlet in the pump body. These outlets are located 180° apart in the pump body and are ducted to the oil line fittings on the front of the pump.

The timing of the alternating alignment of inlet and outlet ports in the Plunger is predetermined by the cam-shaped lower end of the plunger.

It is thus seen that oil pump output volume is regulated both by crankshaft speed and throttle setting.

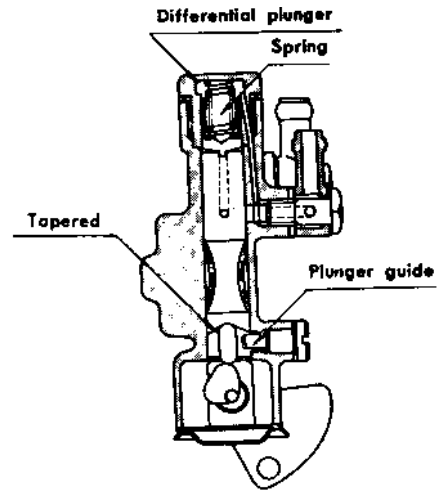

Fig. 103

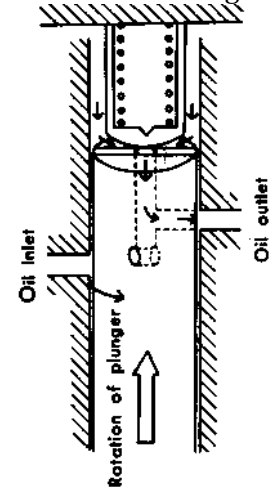

Fig. 104

B. Adjustment

The entire oil injection system is designed to provide the correct oil mixture at all speeds. The only adjustment it will ever need is the cable adjustment. The oil pump volume is affected by the position of the throttle and varies from 20 to 1 mixture at full throttle to 100 to 1 at idle. To adjust the oil pump control cable proceed as follows:

1. Remove left carburetor cover.
2. Turn throttle grip to maximum open position.
3. Check the oil pump control arm (where the cable is connected) and note the pin in the oil pump body and 2 stops on the control arm. (Fig. 107). At the maximum open throttle position the stop should be within $\frac{1}{8}$ inch of the stop pin. If the stop clearance is open more than $\frac{1}{8}$ inch or the stop is closed against the pin, adjustment is necessary.

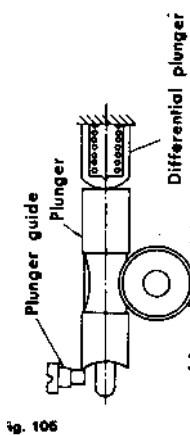
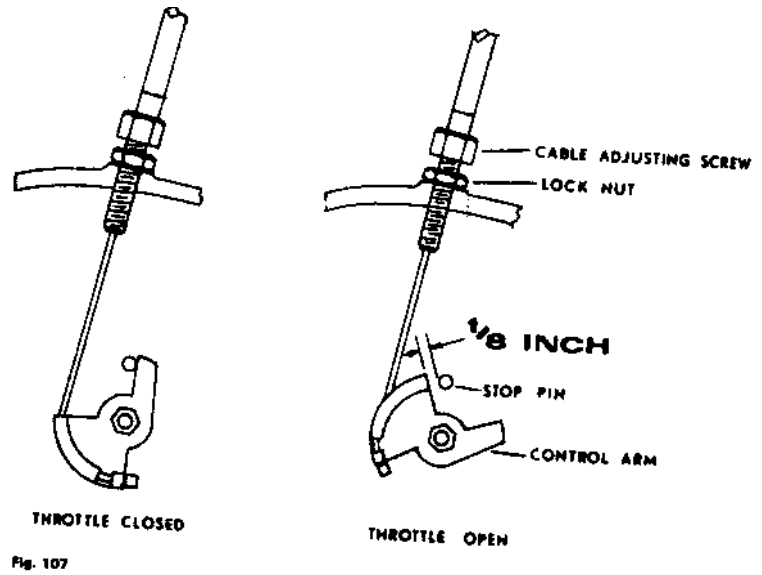

Fig. 106

4. Cable adjustment is made at the cable adjusting screw located above the left carburetor housing, directly in front of the generator. Loosen cable adjusting screw lock nut and turn adjusting screw in for additional stop clearance and out for less until 1/8 inch of stop clearance is observed with the throttle at maximum open position.

NOTE:

1. Do not adjust to less than $\frac{1}{8}$ inch clearance.
2. When throttle is closed after adjustment, the oil pump control arm may not return to its closed position and may appear to be faulty. However, the oil pressure in the pump sometimes holds the control arm open when it is operated without the engine running. This can be checked by running the engine or operating the kick starter.



C. Special Attention — Pump Modification

Bridgestone 175 Dual-Twins manufactured after October, 1965, are equipped with a modified oil injection pump. The new pump is equipped with ball and spring check valves in each of the pump body oil outlets.

The springs fit inside the union bolts which are unchanged from previous models.

DISMANTLING OIL PUMP

1. Ball check valves are installed only in the outlet ports (Never in the inlet port.)
2. Ball check valves cannot be installed in the old style pumps that were not originally equipped with them.
3. When assembling the unit, first install the ball in the outlet port hole. Next, install the spring into the union bolt. Then with the oil line connector and picking washers installed on the bolt, screw the bolt into the outlet port hole.

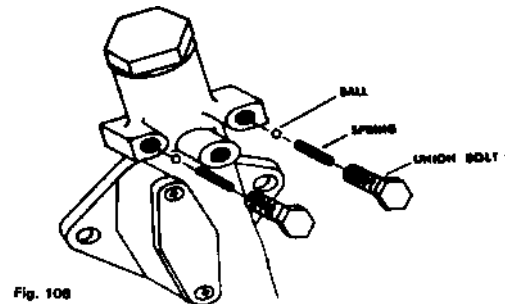

4. The style of oil pump can be determined by viewing into the outlet port holes. The outlets on the old style pumps have no ball valve seats machined in them and the check ball will pass through the outlet, into the oil pump body.

- The new style pumps have check ball valve seats machined in the outlet ports.
5. New style oil pump assemblies are interchangeable with the old style assembly. An additional change was made in Feb., 1966, Serial No. 16B. This change incorporates the ball and spring check valves into a new style outlet connector.

"Brass Check Valve Connectors"

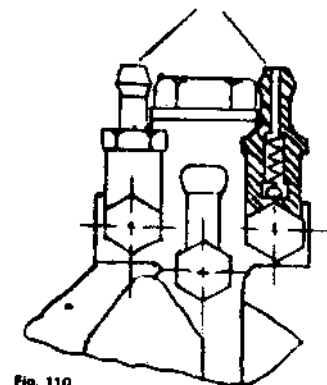

The ball and spring are assembled inside of the new connector and eliminate the possibility of incorrect assembly or loss of these parts.

The new connectors are easily identified because they are made of brass instead of aluminum. These new connectors are interchangeable on any of the old type pumps. When they are installed on old type pumps, the ball and spring must be eliminated from the connecting bolts.

Any old type pump can be converted to the latest style by installing 2 of these new outlet connectors. The old type union connector has been abolished.

A simple check of the oil injection system can prevent serious damage when the machine is operated. Dirty or plugged oil lines, tanks, or filter could prevent the oil flow from the oil tank to the pump.

Whenever a new cycle is serviced, the oil supply line to the pump should be removed at the pump and checked for oil flow.

If a good supply of oil is not available at this line, check the tank, filter and lines and correct as necessary. Oil must flow freely from this line to supply the engine with the proper lubrication.

ELECTRICAL EQUIPMENT - 50, 60 Sport, 90cc

A. Ignition System:

The ignition system consists of a single magneto coil to provide the necessary current, a condenser, contact breaker assembly, an externally mounted dual winding high tension coil, and spark plug.

Contact Breaker:

The contact breaker assembly is mounted on the magneto armature plate. The actuating cam is located on the crankshaft. The contact points should be checked periodically. If the contact points are rough or pitted, replace them. When installing new contact points, carefully wipe the surfaces with a lint free paper to remove any residue of grease from the point surfaces which will drastically affect the functioning of the ignition system.

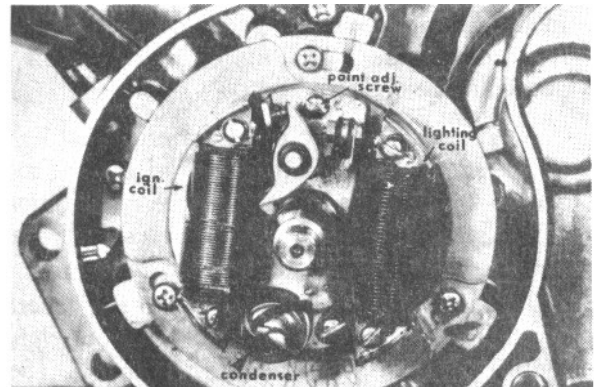

Fig. 111

Ignition Timing: Incorrect ignition timing can cause problems not directly related to ignition such as poor fuel consumption, overheating, hard starting when engine is hot, spark plug burning or fouling, and even extreme engine damage. Therefore, when diagnosing an engine problem, always check and adjust timing first.

CAUTION: Never, under any circumstances, should an engine be run with advanced timing. There is, however no danger in running the engine with the ignition slightly retarded. In fact, higher RPM and increased performance will be attained if timing is retarded 2 degrees from the factory setting.

TO SET TIMING:

1. Remove the magneto case cover and locate the timing marks. One mark is engraved on the side of the flywheel and the stationary mark is a cast "pointer" on the magneto case cover. (See Fig. 111)
2. Rotate flywheel until points are visible through opening in flywheel and timing marks are approximately aligned.
3. Connect one lead of an ohm meter and continuity tester to one of the black wires leading from the magneto. Connect the other lead to any convenient ground on the machine.
4. Position the flywheel timing mark above the magneto case (stationary) mark. Very slowly rotate the flywheel in a counter-clockwise direction (direction of engine rotation) and stop precisely at the point at

which the lowest meter reading occurs or at which the continuity tester light dims. (Note that the ohm meter never reads "0" or the light never goes out entirely because the condenser is grounded). This is the point at which the spark plug fires.

5. When this point has been located, note the relationship of the timing marks to each other. The best setting is about 2° retarded from the ignition angle established by the perfectly aligned timing marks. The ignition mark is 3/32" below the center of the stationary mark, (See Fig. 113)

• **CAUTION:** adjustments *must* be made if ignition occurs *before* the flywheel mark reaches the magneto case mark. (In this case timing is too far advanced.)

6. To adjust timing, measure point gap at its widest open position. (The timing marks will not be aligned when this gap is measured.)

a. To retard spark, close the point gap by .001" at a time until the light dims (when the flywheel mark is 3/32" below the magneto case mark. Secure the point adjusting screw and recheck.

b. To advance spark, open the point gap .001" at a time until the tester light dims when the marks are aligned as in Fig.113.

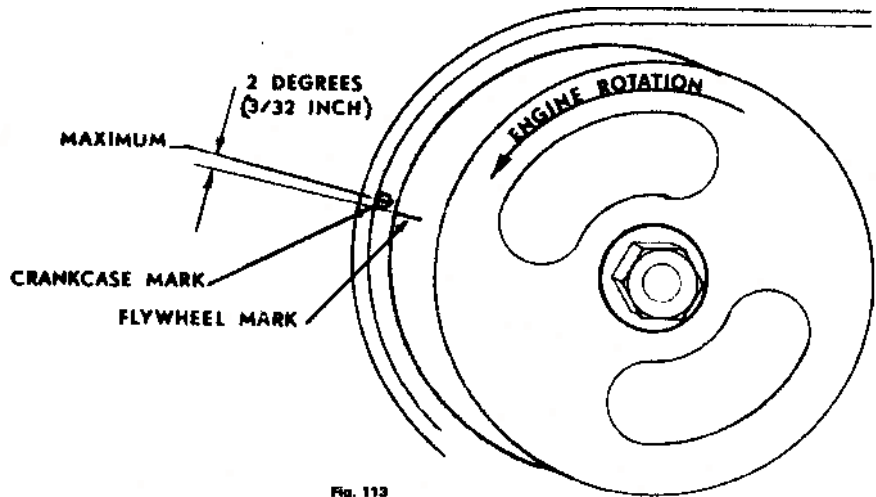

• **NOTE:** It should be possible to time the engine by point adjustment alone if the magneto armature plate has not been moved from its factory setting. The contact point gap can be anywhere between .012 to .016".

• If the engine cannot be timed with the resulting point gap within this range, loosen the three armature plate screws and move the plate slightly in the direction you want the flywheel mark to move for proper alignment as shown in Fig. 113. Then proceed to make fine timing adjustments as set forth above.

Condenser: (Fig. 111) The condenser is mounted on the armature plate and its function is to absorb the current generated when the contact breaker points open. It also assists the functioning of the ignition coil. Always check the condenser whenever the contact points are changed in the event that it might need changing too should it not meet the specifications required.

Spark Plug: The table below indicates the correct spark plugs for the 90cc, 50cc Sport and 60cc Sport models:

MODEL	PLUG BRAND	USE CODE				
		A	B	C	D	E
BS-50Sport	NGK	B-7	B-6	B-8C	B-8C	B-8N
BS-60Sport	Champion	J4 or	J8 or J8J	J62R	J60R	J57R
BS-90	NGK	B-7H	B-6H	B-7HC or B-	B-	B-
BS-90 Trail	Champion	L62R	L7	L-60R	L57R	L-54R
BS-90	NGK	B-7H	B-6H or B-	B-7HC or B-	B-	B-
Mountain	Champion	L62R	L7	L60R	L57R	L-54R

KEY TO USE CODE:

- A Standard plug for break-in and normal use.
- B Hotter plug for low speed use and when standard plug fouls easily.
- C Colder plug for high speed use and when standard plug burns easily.
- D Cold plug. Standard for competition use.
- E Extremely cold plug for high speed racing. Will operate well only at extremely high temperatures. Starting may be difficult with this plug. Not recommended for normal use.

Correct gap on all plugs is between .024 – .027". The spark plug should be checked at least every 2,000 miles. A worn or dirty plug produces weak spark and causes hard starting, low power output, irregular rpm and damage to the ignition coil.

The spark plug should be checked and cleaned periodically with a stiff wire brush and gasoline or other cleaning solvent. The use of an abrasive in cleaning the spark plug is not recommended since abrasive particles may be introduced into the combustion chamber and result in cylinder damage.

B. Testing the Ignition Coil:

The ignition coil can be tested efficiently by connecting the spark plug cap to one lead of a gap tester. Ground the other lead of the tester and kick the kick starter. A spark should jump the quarter-inch (¼) gap. If the spark does not jump this gap, suspect that the ignition coil is defective. Points, condenser, and timing should be checked, however, before replacing the ignition coil.

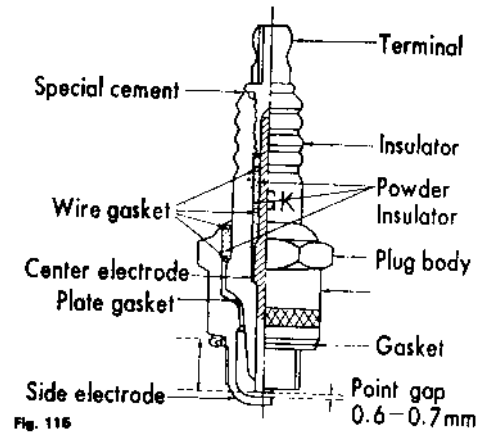

C. Technical Standards: The technical standards of electrical components are indicated below:

DESCRIPTION	SPECIFICATIONS	MODELS	
		50, 60 Spt	90cc
Condenser	Capacity in Microfarads — 0.25 to 0.30 mfd	X	X
Ignition Coil (Primary)	Operating Voltage — 0.5 volt	X	X
Ignition Coil	Operating Amperage — 1.5 to 2.5 amps	X	X
	Primary Continuity — 1.5 to 2.0 ohms	X	X
Lighting Coil	Secondary Continuity — 8000 to 9000 ohms	X	X
	Continuity — Yellow wire to ground		
	0.2 ohms	X	
	0.5 ohms		X
	Continuity — White wire to ground		
	0.1 ohms	X	
	0.5 ohms		X

NOTE: Refer to Troubleshooting section for proper testing procedures in checking generator and charging system on B/S 175 DT.

D. Lighting System:

The magneto armature plate also contains a lighting coil. (Fig. 111) The lighting coil provides current to the headlight and taillight. It also provides AC current to the selenium rectifier which converts this current to DC to "trickle" charge the battery. The battery is a 6 volt-4ampere hour battery furnishing current to the brake light and the neutral gear indicator light. The battery also functions as a stabilizer in the electrical circuit. At high speeds, the magneto puts out from 12 to 18 volts. This current passes through the battery which stabilizes it at 6 volts. It is important that the battery is fully charged at all times since a discharged battery will not offer sufficient resistance in the electrical circuit. When battery charge is low, the headlight and taillight bulbs will be burned out instantly when they are turned on.

E. Testing the Lighting Coil:

The efficiency of the lighting coil can be checked by connecting an ammeter of approximately 2 ampere reading capacity in series with the battery fuse as indicated in the drawing below.

Start the engine and measure the current at approximately 2,500 rpm's and approximately 8,000 rpm's.

With the key switch in the "ignition only" position, at 2,500 rpm the current should measure 0.1 amp. Voltage should register more than 6 volts. At 8,000 rpm's, the voltage should register less than 9 volts. If the measurements are within plus or minus 10 to 20 per cent of the standard rate indicated, the coil is satisfactory. If it is above or below these tolerances, the lighting coil should be replaced.

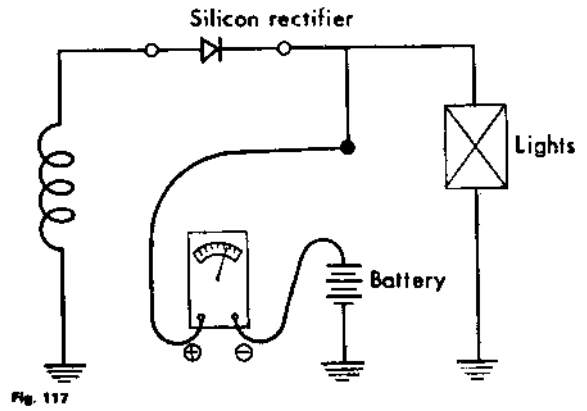

F. Selenium Rectifier:

The selenium rectifier transforms AC magneto into DC current for charging the battery.

Running the machine in the daytime without the battery or fuse in place will damage the rectifier and burn out light bulbs. The battery should be kept fully charged. Specific gravity at approximately 70° F. should read 1.260 on a fully charged battery.

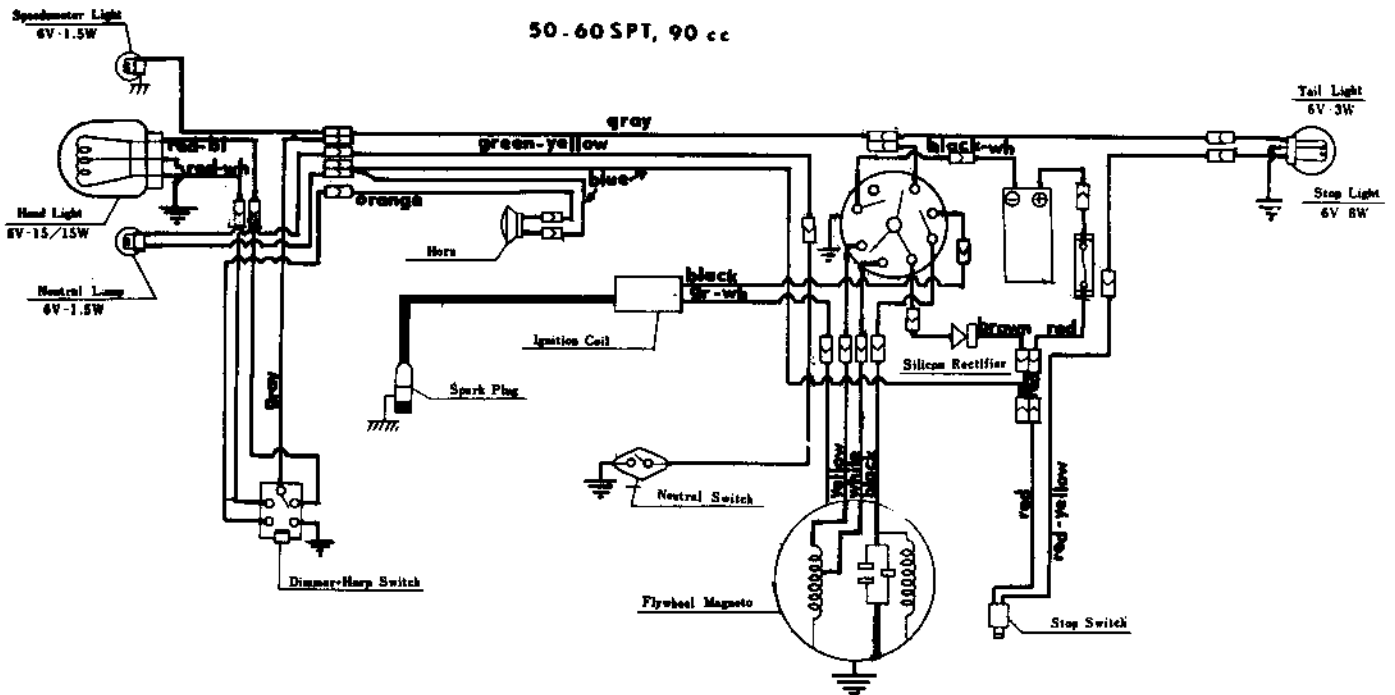

G. Battery Charging (50-60 Spt)

Listed below are two methods of increasing the charge rate on the B/S 50-60 Sport.

1. Connect both the yellow wire and the white wire from the key switch to the yellow wire from the charging coil in the magneto. The white wire from the magneto is left disconnected. This wiring change will slightly increase the charging rate.

2. For chronic problems caused from the cycle being driven only at very low speeds, the charging coil from the B/S 7 Standard can be installed to increase charging.

NOTE: When either method is used, battery water should be checked frequently and water added as necessary.

ELECTRICAL EQUIPMENT - 175 DT

The ignition system consists of contact breakers, condensers, ignition coil, spark plugs, etc. Battery low voltage current is converted to high voltage current by the ignition coil. High voltage current is supplied to the spark plug and, when timed by the contact breakers, ignites the fuel mixture in the cylinder.

Contact Breakers: Two contact breakers are fitted on the AC dynamo. The AC dynamo is turned through the pinion drive gear, driven gear and timing gear. The timing gear turns one full revolution when the crankshaft turns two full revolutions. The timing gear and point cam are fixed on the dynamo shaft and turn with it. The engine of the BS 175 DT is a two-stroke two cylinder engine so two explosions occur every time the crankshaft makes one full revolution. As the speed of the AC dynamo is one-half of that of the crankshaft, contact points must supply four sparks for each revolution of the dynamo, so two cams and two sets of contact breakers are installed. One contact breaker opens each 90° (¼ turn) of cam rotation and high voltage current is induced in the ignition coil.

Contact breaker points should be kept bright and smooth. If point surfaces are rough or pitted, polish lightly and evenly on an oil stone until the surfaces are smooth. (If points cannot be repaired, replace with new ones.) After polishing, wash the point surfaces with gasoline or thinner and wipe dry with a clean cloth.

Ignition timing:

- **NOTE:** Do not attempt to adjust left timing until right timing is completed. Movement of generator during right cylinder timing adjustment will change left timing.

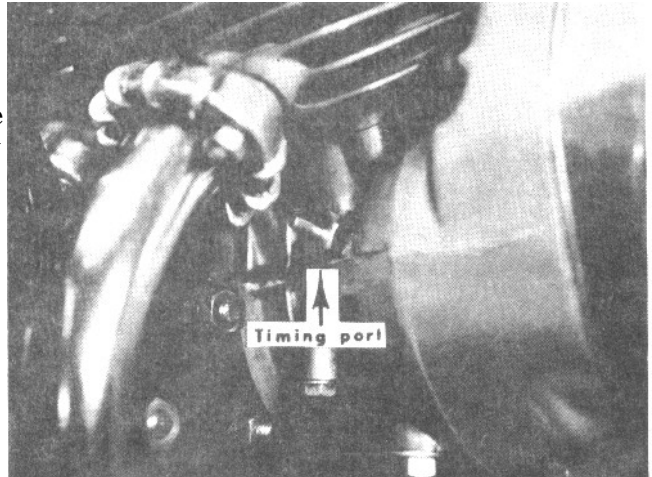

Fig. 112

TO CHECK TIMING - RIGHT CYLINDER

1. Remove spark plugs.
2. Remove left carburetor air pipe.
3. Remove point cover from left end of generator and adjust both sets of points to .012"-.016" at their widest point.
4. Rotate crankshaft by putting transmission in 4th gear and turning rear wheel until the right piston is at top dead center as viewed through the spark plug hole.
5. Install timing screw and bar into timing hole at front of engine (fig. 112). This item is packed in the cycle tool kit.
6. Connect one lead wire of a continuity test light to the right point condenser lead wire at the condenser with the key switch in the off position. (Test light is now off) The other test light lead wire is grounded to engine.

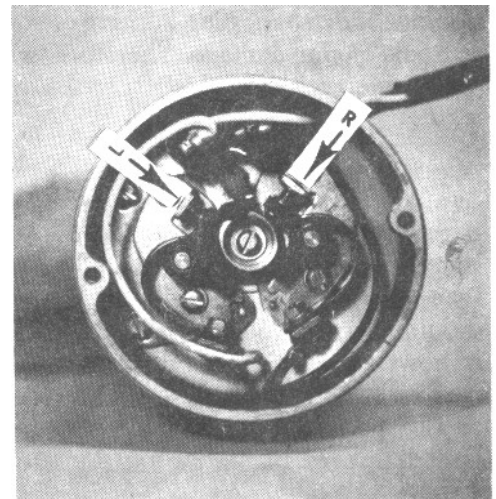

Fig. 114

- NOTE: As you face the open end of the generator, the points and condenser set on your right, control the firing of the right cylinder. (See Figure 114.)
7. Rotate engine backwards by turning the rear wheel backwards until the right points close and test light is on.
 8. Now hold slight pressure on the timing bar and rotate the engine forward until the timing bar engages the slot in the crankshaft. If the timing is correct, the test light will have just gone out at this point.

RIGHT CYLINDER TIMING ADJUSTMENT:

If the test light did not go out (timing is too slow or retarded) or went out before engagement of timing bar (timing too fast or advanced) proceed as follows:

1. Remove air cleaner.
2. Loosen generator mounting clamp nut ("A", fig. 114)
3. Slightly loosen generator positioning screw ("B", fig. 114).
4. With the timing bar inserted into the crankshaft, rotate generator counter-clockwise to slow or retard the timing or clockwise to advance the timing until the light has just gone out and retighten generator position screw and clamp nut. Recheck timing by observing the light as the timing bar engages the slot in the crankshaft. (It should just go out).

TO CHECK TIMING-LEFT CYLINDER:

1. Rotate engine by turning rear wheel until left piston is at top dead center as observed through spark plug hole.
2. Connect one test light lead to left point condenser lead wire at the condenser. (The other test light lead is grounded). The light is now off.
3. Rotate engine backwards by turning rear wheel backwards until the left points close and the test light is on.
4. Now hold a slight pressure on the timing bar and rotate the engine forward until the timing bar engages the slot in the crankshaft. If the timing is correct, the test light will have just gone out at this point.

LEFT CYLINDER TIMING ADJUSTMENT:

1. If the light did not go out (timing slow or retarded) or if the light went out before engagement of the timing bar (timing too fast or advanced) proceed as follows:
2. Loosen the 2 point timing plate screws ("A", fig. 116) and, with the timing bar inserted into the crankshaft, move the plate counter-clockwise (down) to slow (retard) the timing or clockwise (up) to speed up (advance) the timing until the light just goes out. Retighten screws. Recheck timing by rotating the engine and observing light as the timing bar engages the slot in the crankshaft. (It should just go out.)

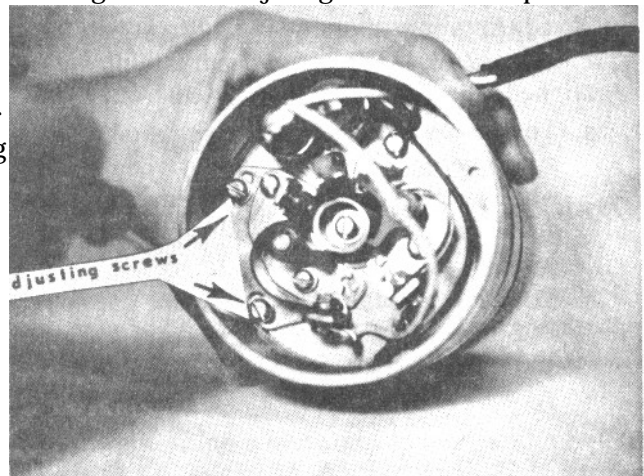

Fig. 116

B. Ignition Coils:

The ignition coil induces high voltage current supplied by the battery by the operation of the contact breakers. The amount of high voltage current induced is determined by the ratio between the number of windings on the primary coil and secondary coil. This high voltage current is supplied to the spark plugs.

The Bridgestone 175 DT has a battery ignition system. Twelve volt battery current flows into the primary coil of the ignition coil. When this primary current is cut off suddenly by the operation of the contact breaker, high voltage current is induced in the secondary coil.

C. Technical Standards:

The technical standards of electrical components are indicated below:

DESCRIPTION	SPECIFICATIONS	175DT
Condenser	Capacity in Microfarads — 0.25 to 0.30 mfd	X
Ignition Coil (Primary)	Operating Voltage — 12.0 volt	X
	Operating Amperage — 1.5 amps (each)	X
Ignition Coil	Primary Continuity	
	Right Coil (White wire to blue wire) — 4.5 to 5.0 ohms	X
	Left Coil (White wire to blue wire) — 4.5 to 5.0 ohms	X
	Secondary Continuity	
	Right Coil (Blue wire to high tension) — 9000 to 10,000 ohms	X
	Left Coil (Blue wire to high tension) — 9000 to 10,000 ohms	X

NOTE: Refer to Troubleshooting section for proper testing procedures in checking generator and charging system on B/S 175 DT.

D. Generator:

The generator fitted to the BS 175 DT is a six pole, magnetic, inner rotor type AC dynamo. The dynamo consists of a rotor into which magnets are cast and a stator consisting of an iron core and wires wound around the iron core. The timing gear is fitted on one end of the rotor and a cam which operates the contact breakers is fitted on the other end. A six pole permanent magnet is contained in the center of the rotor.

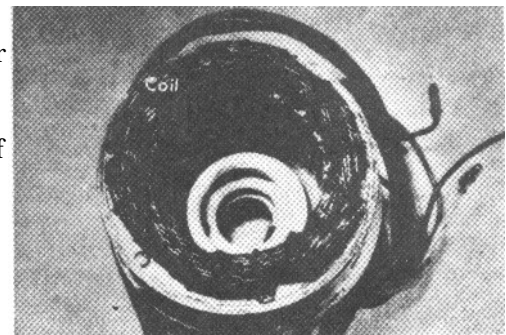

Fig. 118

To increase output, anisotropic cast magnets, which are specially treated for magnetizing, are used. The principle of the generator is the same as that of a conventional magneto, but the stator consists of three coils as shown in Fig. 119, so the dynamo generates three phase alternating current.

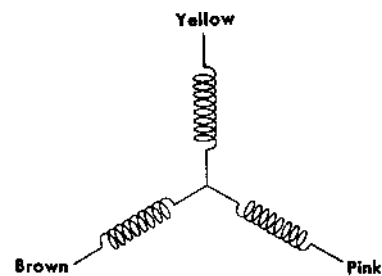

Fig. 119

Outstanding features of the magneto type AC dynamo are good resistance to vibration, capability for high speed operation, etc. This type of dynamo is particularly suitable for high speed motorcycles.

All Bridgestone 175 models after serial No. 16G 11761 are equipped with an improved type generator. This new style generator is driven by an extra gear and is turning at crankshaft speed rather than 1/2 crankshaft speed as did the older type. NOTE: Timing procedure is the same as old style except points for right cylinder are located at the top and points for left cylinder are located at the bottom of the generator.

E. Selenium Rectifier:

As the dynamo mounted on this motorcycle is a six pole type AC Dynamo with large output, a selenium rectifier with a large area is used. The three phase bridge all-wave rectifying system is used, so that charging performance is excellent. As show in the illustration, the charging current flows in the direction indicated by a solid arrow during half a cycle and in the next half cycle flows in the direction indicated by a broken arrow. Charging current always flows in the same direction and the AC current is rectified most effectively.

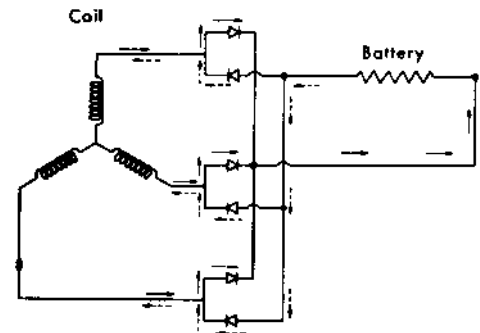

Fig. 120

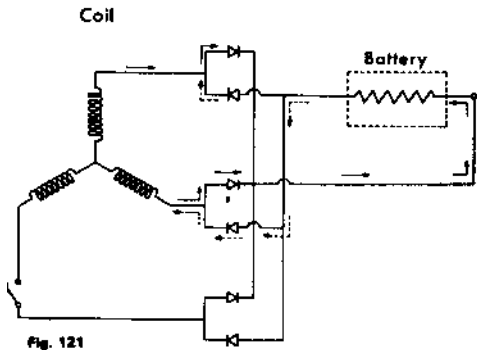

Fig. 121

Care must be taken to prevent high temperatures in the rectifier, wetting with water and handling. No trouble from high temperatures will be experienced if the rectifier is mounted in a properly ventilated position. Take care not to wet the rectifier when washing the motorcycle.

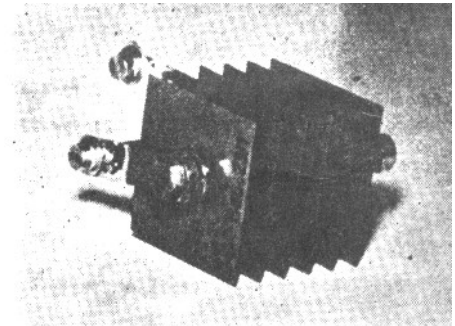

Fig. 122

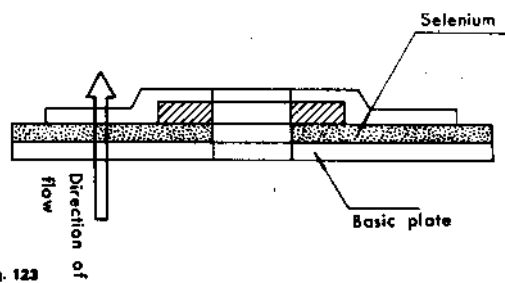

Fig. 123

If the dynamo operates with the secondary circuit (DC side) of the rectifier disconnected and voltage rises too high, sparks will be generated in the synthetic materials in the layers of the selenium rectifier.

Spots where sparks are generated will be burned and electrical current will flow in the reverse direction through the burned parts so that electrical current from the battery will flow to the ignition coil when the engine stops. This will decrease the magnetic power of the generator. Take care not to run the

engine with the selenium rectifier disconnected.

F. Battery:

AC current generated by the AC Dynamo is rectified to DC current by the selenium rectifier and charged into the battery. All current for operation of the motorcycle flows from the battery. The battery should be kept in good condition at all times since electricity for all electrical equipment is supplied by the battery. The capacity of the battery is 12 V-6 AH. The battery should be checked periodically by the rider or the dealer. (See charging specifications for all models in opposite column.)

G. Headlight:

The headlight includes a 12 V, 35 W main beam and a 12 V, 25 W dim beam. The battery is the electric source for the headlight. Riding will be dangerous at night if obstacles cannot be seen clearly. As the headlight of the Bridgestone DT is operated on battery current, it remains bright regardless of engine speed and riders can enjoy safe riding at night.

H. Spark plugs:

NGK B-8H spark plugs are standard for the Bridgestone 175 DT. Be sure to use the proper spark plugs as the engine cannot develop 100 percent performance if an incorrect spark plug is used. The spark plug is proper for the engine when the spark plug insulator is light brown in color. If the insulator is black or

carbon accumulates on it, use a hot type of spark plug, that is one with a smaller number. If the insulator has a bleached appearance, use a cold type of spark plug, or one with a larger number.

BRAND	STANDARD	IF PLUG FOULS EASILY (Slow Speed)	IF PLUG BURNS EASILY (High Speed)
NGK	B-8 H	B-7 H B-7 HC	B-8 HN B-9 H
CHAMPION	L-58 R	L-5	L-56 T L-55 T

175 DT

WIRING DIAGRAM

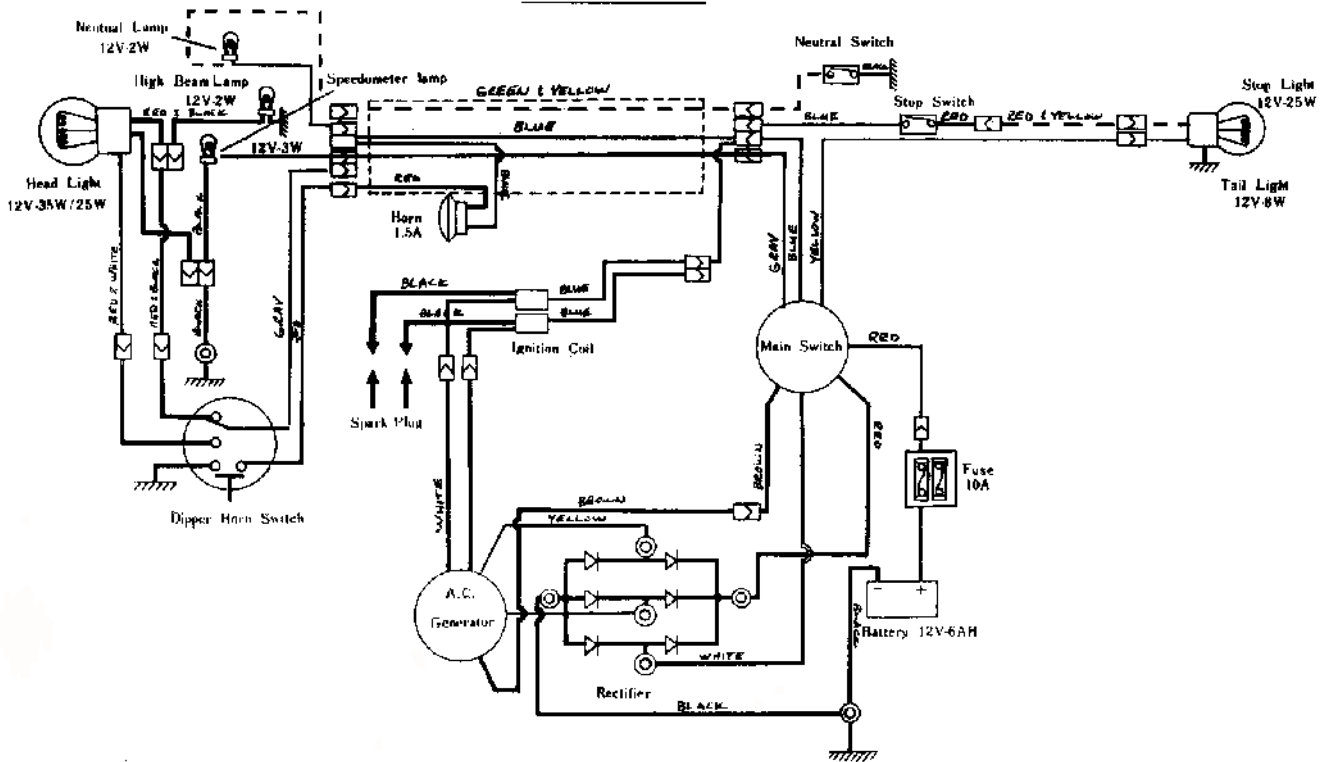

Dry Charged Storage Batteries

ALL MODELS

The fully charged battery acts as a voltage stabilizer in the electrical system. Because the magneto delivers considerably more current than the rated voltage of the system, a fully charged battery is essential as a buffer between the current generating source and the various light bulbs on the cycle.

A discharged battery does not provide sufficient electrical resistance to perform this "buffer" function and light bulbs will be burned out when they are switched on due to the excessive current reaching them from the magneto or generator through the discharged battery. For this reason, it is important that the dealer properly fill and charge the battery just prior to delivering the machine.

1. Fill the battery to proper level with 1.260 specific gravity electrolyte.

2. Allow battery to stand for 2-8 hours without charging.
3. Inspect liquid level and add more electrolyte, if necessary.
4. Measure specific gravity with a hydrometer. Table 1 indicates the approximate degree to which the battery is charged (stated as percent charged) and the approximate ampere/hours of charge which will be necessary to bring the battery to a fully charged condition.

SP. GR.	% CHARGE D	CHG. REQ. (IN AMP/HRS)
1.260	100%	0
1.220	75%	18 A/H
1.160	50%	30 A/H
1.105	25%	45 A/H

- While it is theoretically possible, rarely, if ever, will a dry charged battery be found to be fully charged when the electrolyte is added.
5. To charge the filled battery, a 2½ A/H charge rate may be used in the initial state of charging. The charge is then completed with a ½ amp. trickle charge. The approximate charging time for each of these two charge rates is indicated in Table 2. This table is based on the hydrometer reading taken in 4 above.

SP. GR @ 70°	APPROX. CHG. TIME @ 2.5 A/H	@ 1/2 A/H APPROX. CHG
1.240	2 Hrs plus	10 Hrs
1.220	4 Hrs plus	20 Hrs
1.160	8 Hrs plus	20 Hrs
1.105	10 Hrs plus	30 Hrs

- NOTE: If battery case becomes hotter than 115° (warm to the touch) charge rate must be reduced immediately. Overheating will cause severe battery damage.
- As a matter of practice, the maximum charge rate depends largely on the air temperature of the area where the battery is being charged. A charge rate of up to 50% of the total charge required (see Table 1) can be used IF TEMPERATURE OF THE BATTERY CASE DOES NOT RISE ABOVE THE POINT AT WHICH IT IS JUST WARM TO THE TOUCH (115° F.). Therefore, the cooler the surrounding air temperature, the higher the allowable charge rate.

CAUTION:

1. DO NOT OVERCHARGE. Take specific gravity readings frequently during charging period.
2. CONNECT CHARGER CORRECTLY. Positive lead to positive terminal; negative lead to negative terminal.

3. Set charger for correct voltage (6V or 12V)

4. DO NOT LET FILLED, UNCHARGED BATTERY STAND LONGER THAN 12 HOURS BEFORE CHARGING.

FRONT FORK:

Operation:

When a load is applied to the front fork, the load is received by the fork springs. At the same time, oil in the oil chamber flows into the oil control chamber and the load is held by resistance of the compressed oil and air and the shock is absorbed.

Oil lock bars are installed inside the bottom of the lower fork legs to prevent the fork from bottoming when receiving severe shocks. When oil moves through the gap between the piston oil and the oil lock bar, shock is absorbed by the resistance of the oil. The oil lock bar is tapered so that oil resistance increases as the front fork shortens.

When the fork lengthens, rebound is dampened by oil resistance generated by the oil flow from the oil control chamber through the oil hole to the oil chamber and by the oil flow through the gap between the oil lock bar and the piston oil hole.

Maintenance:

If it is ever necessary to add fluid to the front fork, use hydraulic jack oil. To insert fluid into the fork, remove the upper bridge bolt on the top of the fork tube. Do not add more fluid than is required:

6 ozs. – 50, 60 Sport

6-7 ozs. – 90CC

7.5 ozs. – 175 DT

To determine the amount of fluid already in the fork, remove the upper bridge bolt on the top of the fork tube. Insert a wire gauge of sufficient length, making certain it touches the bottom of the tube. Remove the gauge and measure the fluid mark. It should measure 6 ½ to 7 inches (50, 60 Spt; 90) or 7 ½ to 8 inches (175 DT).

If no gauge is available, remove the screw at the bottom of the outer tube and drain the fluid. Reinsert the correct amount (in ounces) for the particular model involved, as indicated above.

NOTE: The front fork assemblies on the B/S 50 Sport model with serial numbers before 13N are sealed units. For these units the above instructions are not applicable. (Loss of fluid would require replacement of the entire inner tube assembly.)

Assembling Front Fork:

CAUTION: When disassembling or assembling the front fork, do not tip inner tube or outer tubes. This will avoid spilling the oil supply.

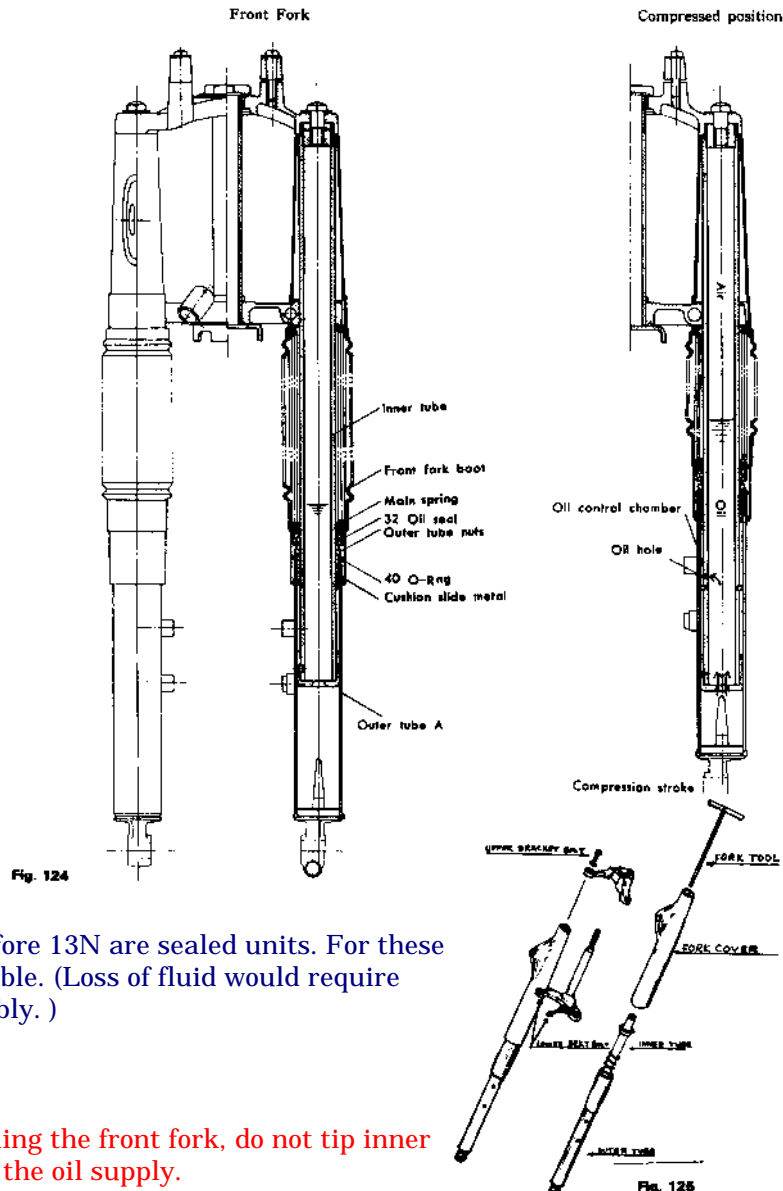

1. To assemble fork, place the cover guide over the inner tube so that it rests on the spring.
2. Insert the fork assembly into the fork cover until the cover guide appears in the slot in the fork cover.
3. Screw Front Fork Tool (special tool) into the top of the inner tube and pull the inner tube up through the top of the fork cover. Temporarily tighten the fork lower bracket bolt.
4. Remove the fork tool and install the upper bracket bolt and tighten finger tight.
5. Loosen the lower bracket bolt to permit proper positioning of the inner tube and then tighten the upper bracket bolt securely. Retighten the lower bracket bolt securely.

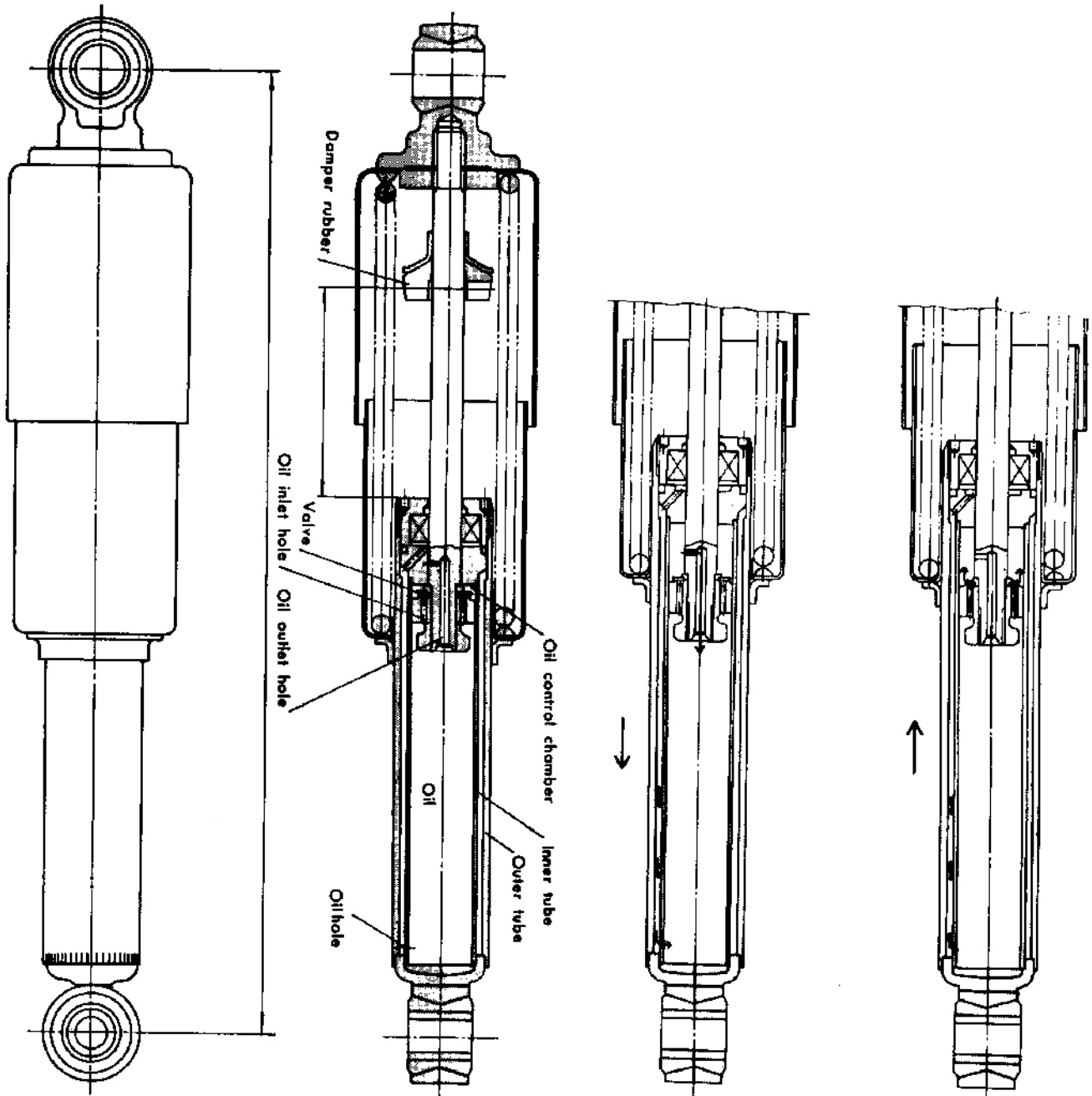

Fig. 126

Return stroke

Compression stroke

REAR SUSPENSION:

The rear suspension system absorbs shocks in a similar manner to the front fork during operation. The rear suspension units are installed between the frame and the rear fork. The rear fork moves up and down, pivoting on a shaft which fits it to the frame.

FRONT WHEEL:

The front wheel brake is installed on the right side of the machine. The speedometer is installed in the hub to keep out water and dust.

Removing Front Wheel:

1. Place a supporting block under the engine.

2. Loosen axle bracket bolt.

3. Remove front torque bar from the hub side.

4. Remove front shaft nut.

5. Pull out front shaft.

6. Raise front fork slightly and detach wheel.

Adjusting Front Brake:

1. Front brake cable hand lever should be so adjusted to allow a play of $\frac{1}{8}$ "- $\frac{3}{4}$ " before the brake acts.

2. Adjust screw as required for proper free play.

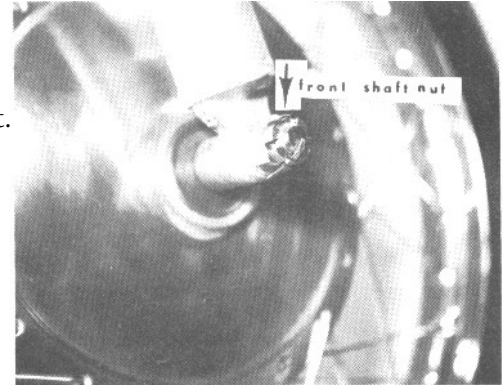

Fig. 127

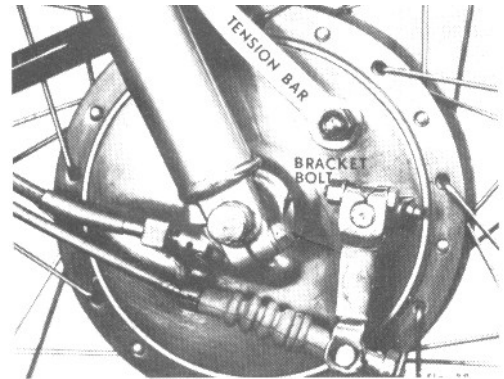

Fig. 128

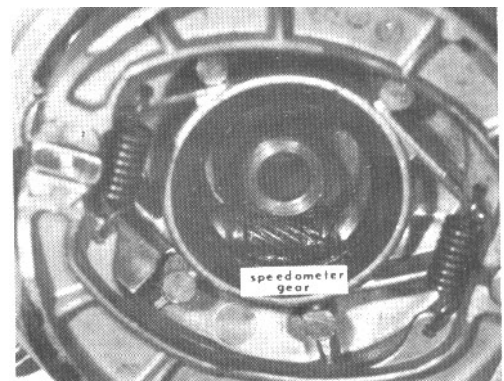

Fig. 130

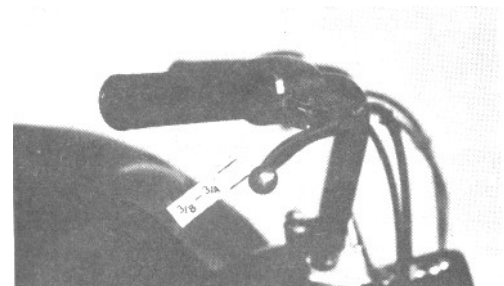

Fig. 135

- Screw in for more play and out for less.
- Lift front wheel and spin to check for brake drag.

NOTE: The B/S 175 DT is equipped with the double cams on the brake drum to assure powerful braking performance.

(1) The play in the brake lever may be adjusted while running with the screw adjuster on the lever

or

(2) With the adjusting lock nuts on the front panel.

(3) Because of the double cams on the drum, the "A" and "B" of cam arms must be set parallel with "1" lock nuts and turn-buckle at all times, to prevent uneven brake action.

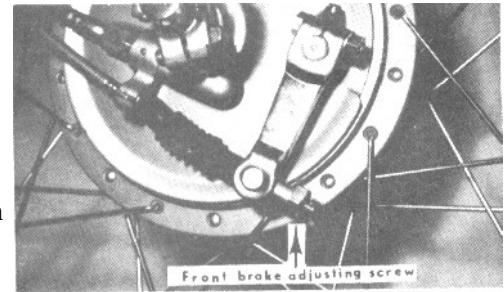

Fig. 136

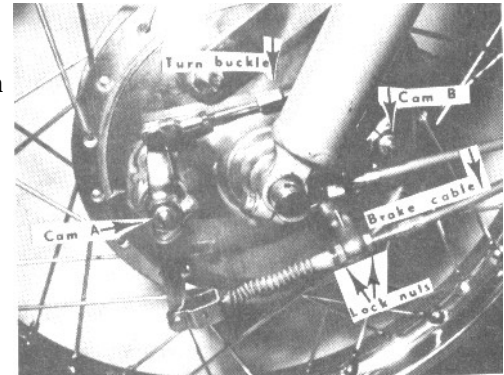

Fig. 137

REAR WHEEL:

The rear wheel has the rear sprocket and drive flange on the left side of the machine and the brake on the right side. To absorb shocks while running, rubber dampers are installed between rear drum and drive flange.

Removing Rear Wheel:

1. Lift the machine on its main stand.
2. Remove brake rod adjusting nut.
3. Remove torque bar from the side of the hub.

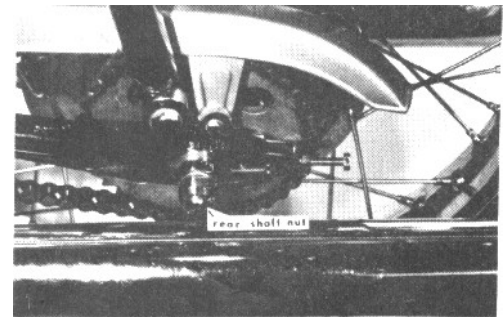

Fig. 131

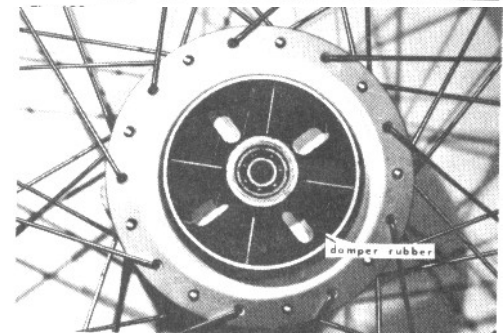
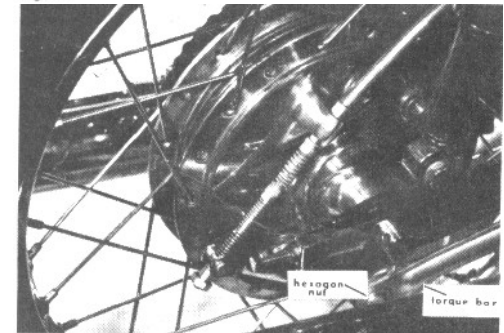

Fig. 133

4. Remove rear shaft nut on left side (the big nut need not be touched.)

5. Pull out rear shaft together with chain adjuster.

6. Removing rear hub collar, wheel will come off the drive flange on the right side.

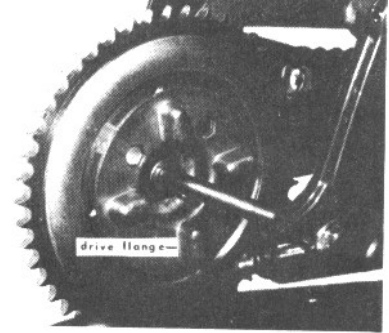

Fig. 134

- Take out the wheel by leaning the machine to the left.

Adjusting Rear Brake:

(1) Rear brake should be adjusted so that brake pedal can be depressed $\frac{3}{4}$ inch – $1\frac{1}{4}$ inches before brake acts.

(2) To adjust, turn brake adjusting nut as required for proper free play. Screw in for less play and out for more.

- Spin rear wheel with transmission in neutral to check for brake drag.

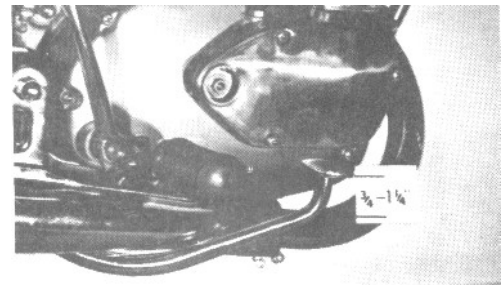

Fig. 138

(1) Chain adjustment is correct when chain slack is approximately $\frac{1}{2}$ inch up or down.

(2) To adjust, loosen rear axle nut and adjust with the chain and adjusters on the ends of the axle, turning them back or forward an equal amount to keep correct alignment of chain wheels.

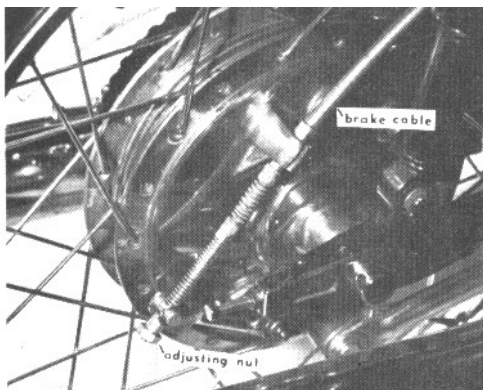

Fig. 139

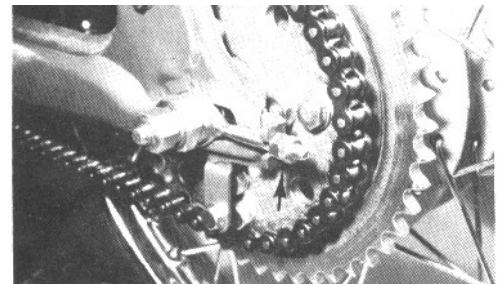

Fig. 140

PRE-DELIVERY SERVICE

After the cycle has been uncrated and assembled, the following service and adjustments must be made to insure proper functioning of the machine:

B/S 90 w/Oil Injection

1. OIL INJECTION: Fill the oil supply tank with a good grade of 2-cycle oil (for best results use Rockford oil).
Caution: The oil tank must never be allowed to run dry.

Remove the right carburetor side cover and loosen, but do not remove, the oil supply line at the pump (the supply line is the rubber line connected at the lower edge of the pump). With this fitting loosened and the oil tank filled with oil, oil should flow freely from the fitting. If it does not, it may be necessary to run your finger along the oil line while squeezing the line to remove trapped air. When oil will flow freely from this fitting, retighten the connector bolt but do not overtighten. The injector pump has a separate gear box and oil filler screw. The gear box oil level should be checked and corrected as necessary. Remove the plug and fill with a pressure type oil can. On early models the phillips screw should be replaced with a 5x6 hex bolt for easier removal.

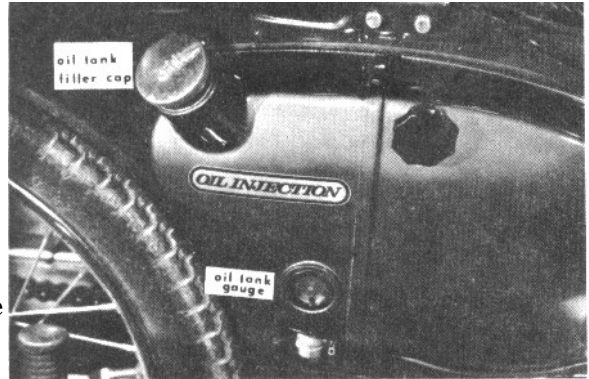

Fig. 141

2. CARBURETOR & OIL PUMP CONTROL CABLE ADJUSTMENTS:

Check and adjust throttle cable at the cable adjusting screw on the top of the carburetor. If the idle adjusting screw is turned all the way in, the throttle cable should be adjusted so that with the throttle closed the outer cable is moved up and down with- out moving the throttle valve. (If the idle screw has been adjusted for proper idle speed, the outer cable should have 1/16 of an inch of free play).

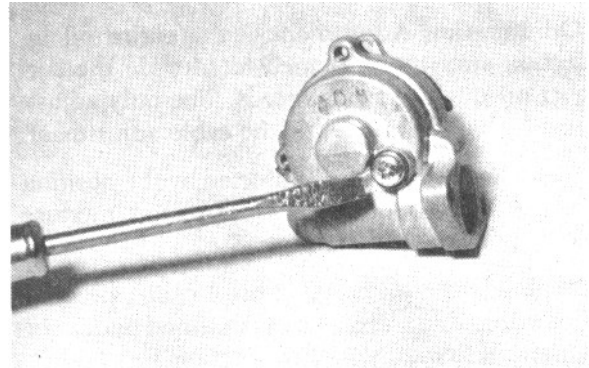

Fig. 142

When the carburetor adjustment has been made, the oil pump control should be checked and adjusted. With the throttle completely closed, the oil pump outer cable should have 1/16 of an inch of free play at the oil pump cable stop before it moves the control arm on the pump from the stop pin. Adjustment is made by the cable adjuster located in the cable by the transmission oil filter plug.

3. FUEL: On a new cycle, the fuel tank should be filled with a 20-1 mixture of regular gas and 2- cycle oil (preferably Rockford oil). This mixture must be used for the first 250 miles of operation only. Thereafter, instruct the customer to fill the tank with regular gasoline only.
4. BATTERY: Fill and charge the battery; follow the procedure as outlined under Dry Charged Storage Battery, page [61](#).

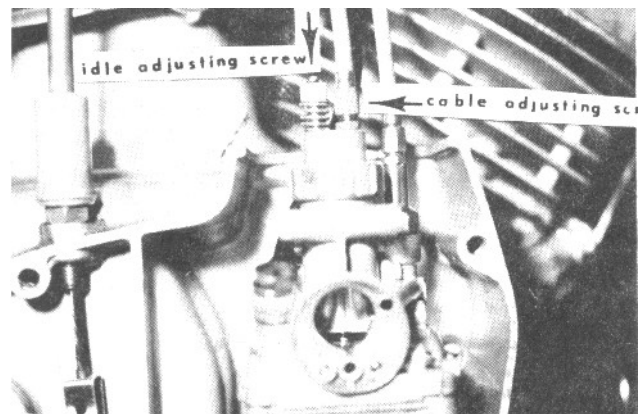

Fig. 144

5. TRANSMISSION: Fill the transmission case with 21 oz. of SAE-10W30 motor oil. Transmission level oil is checked by removing the oil plug located just in front of the kick starter shaft. **Caution: Do not overfill the transmission case.**

6. ADJUSTMENTS:

- A. Tire pressure 24 to 26 lbs. front; 26 to 30 lbs. rear.
 - B. Brakes: Check and adjust as described in Owners' Manual.
 - C. Horn: Check for proper operation.
 - D. Lights: Check all lights for proper operation.
 - E. Axle Nuts: Be certain that both the front and rear axles are properly secured.
 - F. Check the chain and adjust as required.
7. The engine should now be started and the carburetor adjusted for proper idle speed. It should be noted that oil injector pump can be checked by visibly watching the oil flow through the plastic oil line.
- **Note:** When the throttle is closed, and the engine is not operating, the oil pump control arm may not return to the stop pin when the throttle is operated. The oil pressure in the pump sometimes holds the arm in an open position, but operating the kick starter or engine will allow it to return to its closed position.

175 DT

1. OIL INJECTION: The oil injection system is factory adjusted for proper operation. Fill the oil supply tank with 2-cycle oil. Be certain to instruct the purchaser to regularly check the oil supply through the glass inspection port. **Caution: It must never be allowed to run dry.**
2. FUEL: Fill the fuel tank with a 20-1 mixture of regular gas and 2-cycle oil (1 quart of oil in 5 gallons of gasoline). This mixture is to be used during the first 250 miles of operation only. Thereafter, instruct the customer to fill the tank with "regular" gasoline only.
3. BATTERY: Fill and charge the battery.
4. TRANSMISSION: Fill the transmission case with 25 ounces of SAE 10W30 motor oil. Transmission oil level is checked by removing the oil level plug located just in front of the kick starter shaft. Do not overfill the transmission case.
5. OIL PUMP GEAR BOX: The Oil Injection pump is gear driven by the crankshaft, and gear cavity oil level must be checked before operation.
 - The gear cavity is located behind the oil pump and left carburetor. This cavity must be kept filled with a good grade of 30 weight motor oil. To fill, proceed as follows:
 - A. Remove left carburetor cover.
 - B. Remove oil level screw. This oil level screw is easily identified because it has a red fiber gasket under it.
 - C. Remove the screw just to the right of the oil pump body. Using a pressure-type oil can, fill the gear cavity through this screw hole. Fill until oil appears running out of the oil level screw hole. (Oil level should reach lower edge of this oil level plug screw hole).
 - D. Replace both screws. Oil level should be checked during the first 500 miles and intermittently thereafter.

6. ADJUSTMENTS:

- A. Tire Pressure – 24 to 26 lbs. Front
 26 to 30 lbs. Rear

- B. Brakes check and adjust as described in owner's manual.
- C. Horn check for proper operation.
- D. Lights check all lights for proper operation.
- E. Axle Nuts be certain both front and rear axles are properly secured. Cotter pin must be installed in castle nut on front axle.
- F. Chain check and adjust as required.
- G. Steering Damper check for proper operation. The damper is intended for use at high speed only. Do not overtighten.
- H. Idle adjust idle, if necessary, by visually checking the position of the carburetor throttle valves. Adjust cable adjusters on top of carburetors so that, with throttle grip closed, 1/32" of free play can be felt in the throttle cable at each carburetor.
- I. Oil Injection Adjustment the entire oil injection system is designed to provide the correct oil mixture at all speeds. The only adjustment it will ever need is the cable adjustment.
 - The oil pump volume is affected by the position of the throttle and varies from 20 to 1 mixture at full throttle to 100 to 1 at idle.
 - To adjust the oil pump control cable, proceed according to the sequence as outlined under Oil injection System, 175 DT, Section B, page [51](#).

8. BREAK-IN: ALL MODELS

- A. First 250 miles: The oil injection tank is filled with 2-cycle oil and the fuel tank is filled with 20-1 gas/oil mixture. Do not exceed 30 miles per hour (40 mph w/ 175DT) for the first 250 miles. To insure proper break-in and to prevent spark plug fouling for the first 250 miles, do not run at any one constant speed.
 - 250-500 miles: Fill the fuel tank with regular gas only. Be certain that the oil injection supply tank is full. Do not exceed 40 miles per hour (50 mph W/175DT) Continuing to vary the speed during break-in will insure for proper break-in.
 - 500-750 miles: Do not run continuous maximum speed. Check the oil injection tank daily. **Caution: Engine will be severely damaged if tank is allowed to run dry.**
 - **Note: A 20-1 gas/oil mixture is used in addition to oil injection for the first 250 to insure proper break-in and priming of the oil pump.**
- B. Never run engine at constant speed during break-in. Run it up to the maximum allowable speed for a minute or two and then back to lower speeds.
- C. Clean the spark plugs every 100 miles during break-in.
- D. Change transmission oil after the first 250 miles and after 750 miles. Then change at regular intervals thereafter.
- E. Check and recharge the battery after the break-in period. At slow speeds the battery does not charge at the normal use rates.
- F. Check frequently for normal chain stretch and adjust as required.

TROUBLESHOOTING: ENGINE

Troubleshooting is a broad category. It covers the search for the cause of such complaints as hard starting, poor acceleration, poor top speed, engine missing, over-heating, short spark plug life, scoring, rough low-speed operation and a multitude of other symptoms. Regardless of the complaint, the best approach to solving any difficulty is a systematic approach which is followed regardless of the nature of the complaint. As a general rule, in following this systematic procedure, you will be able to locate the cause and make a prompt and inexpensive correction.

Outlined here and on the following pages are recommended procedures to follow in systematically searching for whatever problem (s) might exist.

I. PRELIMINARY CHECK:

When the cycle does not accelerate or attain rated top speed, check:

TIRES Properly inflated?
BRAKES Dragging?

AIR CLEANER Dirty?
MUFFLER Carbonized?

TRANSMISSION . Overfilled?
CHAIN Too tight? Dry?

FUEL COCK . . On? Plugged?
FUEL TANK VENT . Plugged?

Deficiencies in any of these areas will seriously affect performance.

II. SPARK PLUG:

Its appearance, if it has been run for any time in the engine, will put it into one of three categories:

It will be normal:

Insulator light brown or gray. Slight electrode wear.

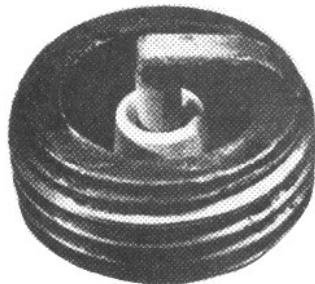

Fig. 145

It will be burned:

Burned or blistered insulator.



Fig. 146

It will be fouled:



Fig. 147

(A) Oil Fouled.
Wet oil deposits.
Minor electrode wear.

(B) Deposit Fouling.
Red, yellow, brown, and white deposits indicate use of incorrect oil or high test gas.

A. PLUG APPEARS NORMAL

Check spark with gap tester. Electrodes should be spaced $\frac{1}{4}$ " apart. "Good" spark will easily jump this gap.

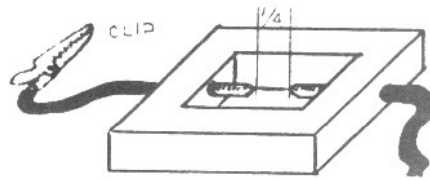

Fig. 148

GAP TESTER

WEAK SPARK

(Spark jumps plug gap but not tester gap)

(1) POINTS

- (a) Worn
- (b) Incorrectly gapped
- (c) Burned
- (d) Dirty

(2) CONDENSER:

- (a) Defective
- (b) Poor solder connection

(3) TIMING:

- (a) Advanced
- (b) Retarded

(4) COIL:

- (a) Defective
- (b) Poor connection
- (c) Leaking spark plug wire

NO SPARK

- (1) Defective Switch
- (2) Disconnected Wire
- (3) Shorted Condenser
- (4) Grounded Points
- (5) Defective Coil
- (6) Shorted High Tension Wire

STRONG SPARK

(Sharp blue spark easily jumps gap)

(1) FUEL SYSTEM

(a) MIXTURE

- Carelessly mixed
- Wrong oil
- Stale or ethyl gas
- Incorrect oil pump adjustment

(b) CARBURETION

- Float level
- Plugged jets
- Plugged passage
- Float valve
- Idle adjustment
- Needle jet adjustment

(c) ROTARY VALVE

- Broken
- Incorrectly installed
- Altered
- Worn

B. BURNED PLUG

- Check spark with gap tester.

WEAK SPARK

(Not likely)

GOOD SPARK

- (1) TIMING
 - (a) Advanced
- (2) FUEL SYSTEM
 - (a) Insufficient Oil
 - (b) Incorrect oil pump adjustment
- (3) CARBURETION
 - (a) Jets or passages plugged
 - (b) Jet needle adjustment
 - (c) Incorrect main jet
- (4) COMPRESSION
 - (a) Cylinder packing
 - (b) Crankcase packing
 - (c) Crankcase drain
 - (d) Magneto side oil seal
- (5) MILLED HEAD
- (6) CARBON FOULING
 - (a) Cylinder head — pre-ignition
 - (b) Excessive compression

C. FOULED PLUG

- Check spark with gap tester

WEAK SPARK

- (1) IGNITION
 - (a) Burned points
 - (b) Point gap wrong
 - (c) Condenser bad
 - (d) Coil defective

GOOD SPARK

- (1) FUEL
 - (a) Mixture too rich
 - (b) Too much oil from pump
- (2) AIR CLEANER
 - (a) Plugged
 - (b) Not installed
- (3) CARBURETION
 - (a) Float level
 - (b) Jet needle adjustment
 - (c) Main jet
- (4) COMPRESSION
 - (a) Rings worn
 - (b) Piston worn
 - (c) Cylinder worn
 - (d) Head gasket leak
 - (e) Stuck rings
 - (f) Scoring
 - (g) "O" ring leak
 - (h) Rotary valve oil seal leak

III. ENGINE OVERHEATING:

The major causes of engine overheating are:

1. Improper break-in procedure.
2. Improper fuel/oil mixture.
3. Incorrect ignition timing.
4. Incorrect spark plug in use.
5. Spark plug incorrectly gapped.
6. Faulty points and condenser.
7. Dirt in carburetor.
8. Carbon accumulation in cylinder ports.
9. Excessively heavy oil in transmission case.
10. Tires underinflated; brake drag; chain too tight.

A. Improper Break-In. One of the most frequent cases of engine damage due to overheating is improper break-in. There appears to be some confusion in the field about the necessity of break-in because some 2-cycle engines, such as chain saws and outboards, do not require it. **IT IS IMPORTANT TO NOTE THAT ALL MOTORCYCLES, REGARDLESS OF BRAND, REQUIRE ENGINE BREAK-IN.**

- All motorcycle manufacturers specify break-in periods ranging from 250 to 2500 miles, depending upon the type of engine used. Friction is greater during break-in until rings have had an opportunity to seat and the cylinder wall has acquired a glaze.
- Bridgestone cycles should be run-in for a minimum of 250 miles. Sustained high speeds should be avoided for at least 500 miles, preferably 1000 miles.

IMPRESS THESE FACTS UPON PURCHASERS:

1. Observe maximum, break-in speeds.
 2. Avoid fast engine warm up.
 3. Avoid fast shifting through the gears.
 4. Avoid overloading.
- Once a Bridgestone cycle is broken in properly, it is the most trouble-free machine available as attested to by the number of large rental operators who are discontinuing other makes in favor of Bridgestone.
- B. Fuel & Oil Mixture. It is important to use the proper oils and correct mixing ratios. Always use a good grade of regular gas mixed with a brand name 2-cycle oil (preferably Rockford Motor Oil), recommended for air cooled engines. Never use special additive oils, or high ratio oils (50:1 or 100:1). Always use 15:1 ratio for break-in 20:1 thereafter.
- C. Incorrect Ignition Timing. The next most frequent cause of overheating is excessively advanced ignition timing. Because of its importance, carefully note and follow the timing procedures.

- D. Incorrect Spark Plug in Use. A spark plug not recommended for use under the particular operating conditions can result in overheating. Select the correct plug recommended for this particular model you may be working on.
- E. Spark Plug Incorrectly Gapped. An incorrectly gapped plug can effect ignition timing. The problem is most frequently found when an American-made plug is installed. The standard equipment NGK plugs are factory gapped within the correct .025"-.028" range. American plugs will almost always be factory set at a wider gap. Gap should be set before installation.
- F. Faulty Points and Condenser. Check point surfaces for wear. Check condensers against specifications as set forth under Electrical Equipment: Technical Standards, page [59](#).
- G. Dirt in Carburetor. This condition, obstructs fuel flow and results in running too lean a mixture, which causes overheating.
- H. Transmission Oil Too Heavy. Excessively heavy oil in the transmission case causes the engine to overwork due to extra drag. The transmission should be filled with the correct amount of S.A.E. 10W-30 motor oil.
- I. Tires, Brakes, Chain. These items must be periodically checked to avoid placing an abnormal load on the engine due to drag.

TROUBLESHOOTING: TRANSMISSION

I. MISSED GEARS:

(1) Check shifter arm pawl. Are the pawl teeth broken ? Check the return spring.

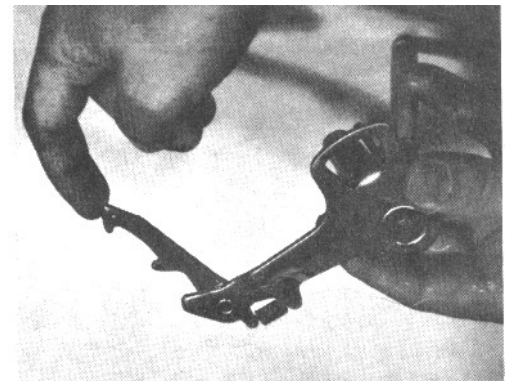

Fig 149

(2) Check the shift drum stopper. Is the spring stretched ?

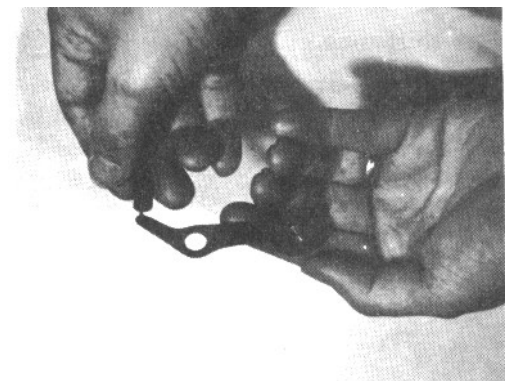

Fig 150

(3) Inspect the gears (especially low gear "B"). Any burred or broken teeth ? Any broken drive dogs ?

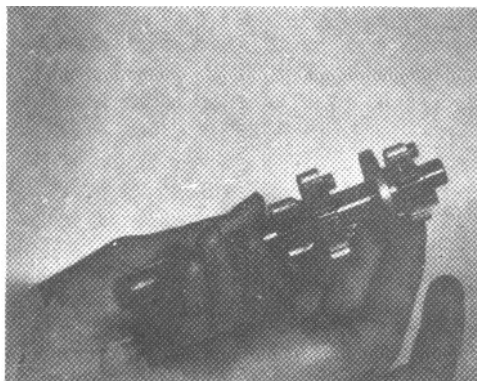

Fig 151

(4) Check shafts for straightness.

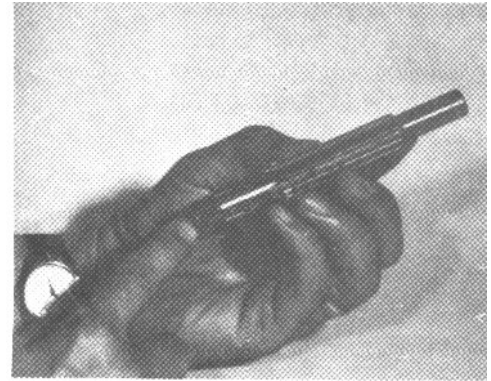

Fig 152

(5) Check the shift forks. Are they bent or broken?

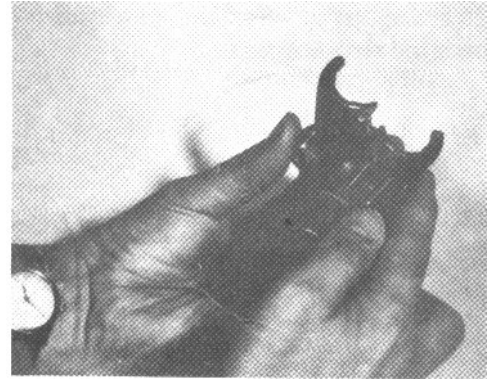

Fig 153

(6) Check the shift pins (end of shift drum). Are there any broken or missing?

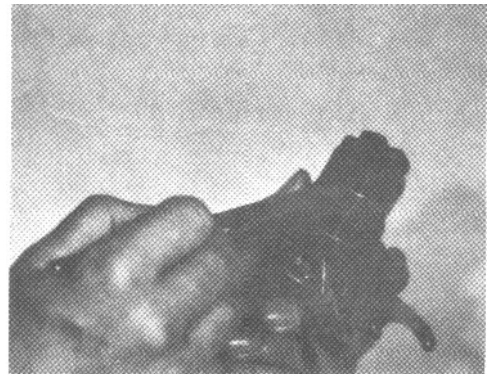

Fig 154

TROUBLESHOOTING: ELECTRICAL

50, 60 Spt; 90cc

I. KEY SWITCH

If a grounded test light does not light with the switch in the "on" position, ground the other battery wire. If the light goes on, the key switch or the wiring to it is defective. (If the light did light before grounding the other wire, the key switch and the wiring to it are O.K.)

II. CHARGING SYSTEM:

Connect an amp meter in the line so that current passes through it. Place the amp meter in the circuit between the battery and the fuse. When the key switch is in the "Off" position, no battery drain should be indicated in the amp meter dial. When the key switch is turned on without the engine running, you should notice a battery drain on the amp meter. With the engine running at approximately $\frac{1}{4}$ throttle, a charging rate of about 1 amp should be seen. With the engine running between $\frac{1}{4}$ and $\frac{3}{4}$ throttle, approximately a 2 amp charging will be found.

III. BRAKE LIGHT SWITCH:

Connect a grounded light bulb to the hot wire of the switch. It should light if the battery is charged and the key switch is O.K. Now connect it to the other lead from the switch. It should light when the brake pedal is pressed. If it doesn't, the switch is bad. If it does light and the brake light doesn't work, the probable cause lies in the bulb or in the wiring between the key switch and the bulb.

IV. HEAD LIGHT:

Connect a test bulb to the headlight wire. If, with the engine running, the bulb will not light when connected to the head light wire, check to see if current is reaching the dimmer switch. If it is, the switch or the wiring to the light is defective. If it does not light, check the wiring to the key switch.

Check the key switch itself by jumping the wire from the magneto lighting coil wire to the lighting hot wire.

V. HORN CIRCUIT:

Connect a light to the hot wire from the battery. If it doesn't light, check the wiring and the battery charge. To check the horn operation, ground the horn switch wire. If you have current to the horn and it doesn't blow, either adjust it or replace it.

VI. SELENIUM RECTIFIER:

A simple check to see if the rectifier is in good condition is to connect the leads of the continuity tester to the terminals of the rectifier. The light should light when the leads are connected one way, but it should not light when the leads are switched. This is because the rectifier should pass D.C. current in one direction only. If the light lights in both connections, the rectifier is defective.

175 DT

In testing the generator and charging system, follow the procedure as listed below to locate the problem exactly and quickly.

1. With the engine off, connect an amp meter into the circuit of the red wire on the battery at the fuse.
2. Start the engine in the day time position of the key switch and observe the amp meter. At idle, the meter should show a discharge of 2 amps. When the engine is run faster (4000 RPM) the meter should read "0". (No charge or discharge) with models equipped with the high-low switch and the switch is in high charge position, the "0" (no charge or discharge) will occur at 3000 RPM.
 - When the engine is run from $\frac{1}{2}$ to full throttle, the amp meter should read 3 to 5 amps of charges. If all the above tests are correct, the battery will stay charged when the cycle is operated for normal use.
3. If in the above test the 2 amp discharge was observed but no charging occurred, suspect a faulty key switch and proceed as follows:
4. Leave the red wire from the battery to the key switch disconnected and reconnect the amp meter, one lead to positive of the battery and the other lead to the red post of the rectifier.
5. Restart the engine and test as in #2. If readings observed in this position are correct, the key switch is faulty and replacement is indicated. If only discharge is observed (or very low charge), 2 amp charge or less with high-low charge switch on or 1 amp rectifier and proceed as follows:
6. Remove all wires from rectifier and connect a D.C. test light, (battery operated) one lead to the black post and then touch the other lead to the yellow, blue, white post one at a time. Now connect the test light in the same manner but reversing the leads, to the black post and use the opposite lead to touch the same color terminals. In the above test, the test light should have burned at all three connections in one test, and the test light should not have burned in the other. (D.C. current will pass through a selenium rectifier in only one direction.) If the test light did not burn according to the above, the rectifier can be

considered faulty. If this test was normal, check the other half of the rectifier by using the red post and touching the yellow, blue, and white and proceed as above.

- If no positive conclusion can be made from this test, substitute another rectifier and test as in #2.
7. If the charge reading is still below the 3-5 amp with the high-low charge switch in the on position and operating the high-low charge switch from on to off does not change the charge rate (at half to full throttle), suspect a faulty switch and connect the brown wire from the generator to the white post of the rectifier; if charging is then correct, replace the charge switch.
 8. Generator Test. The generator Can be checked with a test light. A battery operated test light should burn when connected to any two of the yellow, blue or brown wires. The test light should not light from any wire, (yellow, blue or brown) when the other test lead wire is grounded to the generator frame.
 9. If all components seem to test satisfactory and charging is still below standard, the generator magnets may be weak and replacement would be necessary.
 10. When checking the charging system always check the terminals on the wires' ends to make sure they have good contact.
 11. For the proper readings, always use a charged battery when testing.
 12. If the charge rate is found satisfactory and battery becomes discharged, the battery may be defective and will not hold a charge. Check the battery after fully charging it and, if the specific gravity of the fluid is not above 1.240, the battery is probably defective. If the gravity is above 1.240 but will drop to below this reading in 24 hours without connecting it in the cycle, the battery is defective.
 13. If both the battery and the charge rate are satisfactory, suspect that the customer is running at too slow an average speed and suggest that he operate the cycle in a lower gear to keep the engine turning faster (especially for very slow speed city driving).
 14. In some cases it has been found that a customer may ride with his foot on the brake pedal so that the stop light burns continuously. It is recommended that the cycle not be allowed to idle more than the normal amount necessary in operating the cycle. These practices help run the battery down and the customer should be instructed against them.

ALL MODELS

Most troubleshooting will involve bulb replacement:

1. Head light bulb burned out ?
2. Tail light bulb burned out ?
3. Lights on in the speedometer head ?

Check the neutral gear switch by grounding the terminal screw to any convenient ground. The neutral gear light should light when the key switch is in the 1st or 2nd position.

It's important that the spring be connected between the break light switch and the pedal. If it is necessary to adjust the throw of the brake light switch, loosen the two adjusting nuts and move the switch either up or down.

The horn on the B/S machines is located directly below the fuel tank. Do not adjust by turning the nut in the center of the diaphragm on the front of the horn. The adjusting screw is located on the back of the horn. This is the only screw or nut on the horn which should be turned.

Make certain the battery is filled properly and charged. The charge should be checked with a hydrometer.

Check the fuse.

Check the charging coil with an ohmmeter according to the specifications under Electrical Equipment, Section C, page [59](#).

INSPECTION AND MAINTENANCE

I. Periodic Checking:

ITEM	PROCEDURE	400 km (250 miles)	3,000 km (2,000 miles)	6,000 km (3,500 miles)
				AFTER BREAK-IN 400 km (250 miles)
Front and Rear Brake Play	Check		X	X
Chain Play	Check		X	X
Mufflers and Exhausts	Clean Carbon			O
Clutch Play	Check		X	X
Carburetor Operation	Check			O
Battery Liquid	Check		X	X
Spark Plugs	Check			X
Contact Point Gap	Check		O	O
Air Cleaner	Check			O
Cylinder Head	Clean Carbon			X
Bolts and Nuts	Tighten		O	O
Fuel Cock Filter	Clean			O
Transmission Oil	Replace		X	X

Items marked "O" should be checked more frequently.

II. Periodic Greasing:

Periodic greasing with a grease gun and lubrication.

ITEM	FIRST GREASING MILEAGE	SECOND GREASING MILEAGE INTERVAL	PROCEDURE
Front Brake Cam Shaft	400 km (250 miles)	3,000 km (2,000 miles)	Grease
Rear Brake Cam Shaft	400 km (230 miles)	3,000 km (2,000 miles)	Grease
Throttle Grip Pipe	400 km (250 miles)	3,000 km (2,000 miles)	Grease
Speedometer Gear Box	6,000 km (3,500 miles)	4,000 km (2,500 miles)	Grease
Front and Rear Wheel Bearings	3,000 km (2,000 miles)	3,000 km (2,000 miles)	Grease
Steering Bearings	6,000 km (3,500 miles)	6,000 km (3,500 miles)	Grease
Oil Felt (Magneto)	6,000 km (3,500 miles)	6,000 km (3,500 miles)	Oil
Cables	1,500 km (1,000 miles)	3,000 km (2,000 miles)	Oil
Chain	400 km (250 miles)	1,000 km (600 miles)	Motor Oil
Stand Tube	3,000 km (2,000 miles)	3,000 km (2,000 miles)	Grease
Front Fork	10,000 km	10,000 km	

(6,000 miles)

(6,000 miles)

220cc. of hydraulic jack oil (or mixture of 70 parts of Spindle oil SAE #60 to 30 parts of # 30 motor oil)

SERVICE STANDARDS

I. CYLINDER COMPRESSION	STANDARD	MINIMUM
50, 60 Spt:	90 P.S.I.	100 P.S.I.
175 DT:	120 P.S.I.	100 P.S.I.
II. PISTON CLEARANCE	MAXIMUM	MINIMUM
50, 60 Spt:	.005 in.	.0025 in.
90/T, 90/M, 90 Std:	.006 in.	.003 in.
90 Spt:	.003 in.	.001 in.
175 DT:	.003 in.	.001 in.
III. RING GAP	MAXIMUM	MINIMUM
	.020 in.	.006 in.
IV. CONTACT POINT GAP	MAXIMUM	MINIMUM
	.016 in.	.012 in.
V. CONDENSER CAPACITY	0.3 uF	
VI. FRONT FORK OIL CAPACITY		
50, 60 Spt:	6 oz.	Hydraulic Jack Oil
90 :	6 1/2 – 7 oz.	Hydraulic Jack Oil
175 DT:	7 1/2 – 8 oz.	Hydraulic Jack Oil
VII. TRANSMISSION OIL CAPACITY		
50/60 Spt, 90:	21 oz.	
175 DT:	25 oz.	
VIII. SPARK PLUG RECOMMENDATIONS		STANDARD
50 Spt:		NGK B-7
60 Spt:		NGK B-8
90 Std/90 Spt:		NGK B-7H
90 T :		NGK B-7H
90 M :		NGK B-7HZ
175 DT:		NGK B-8H
IX. TIRE PRESSURE	24-26 lbs. Front 26-30 lbs.-Rear	
X. CRANKSHAFT END-PLAY	MAXIMUM	MINIMUM
	.020 in.	.003 in.
XI. CLUTCH ADJUSTMENT	d" - 5/8" free play at clutch lever end	
XII. OIL PUMP ADJUSTMENT		
90cc:	w/throttle closed, oil pump outer cable should have 1/16" of free play before it moves control arm	
175DT:	at maximum open throttle, adjustment should allow space of 1/8" between control arm and stop pin.	
XIII. CHAIN ADJUSTMENT	d" slack, up or down	
XIV. FLOAT LEVEL		
50/60 Spt, 90/T, 90/M, 90 Std:	25/32" (1/32" above 3/4") 15mm carburetor	
90 Spt, 175 DT:	23/32" (1/32" under 3/4") 17mm carburetor	
XV. FRONT BRAKE ADJUSTMENT	d" - 3/4" free play at lever end before brake acts.	
XVI. REAR BRAKE ADJUSTMENT	3/4" - 1 1/4" brake pedal depression before brake acts.	
XVII. TORQUE SETTINGS		
Cyl. Head Nuts	125 in./lb. (140 in./lb. – 175 DT)	
Pinion Gear Nut	250 in./lb.	
Clutch Nut	110 in./lb. (50, 60 Spt)	
	120 in./lb. (90 cc)	
	130 in./lb. (175 DT)	
Clutch Thrust Plate Bolts . .	45 in./lb.	

Spark Plug	175 in./lb.
5mm Bolts	40 in./lb.
6mm Bolts	60 in./lb.
8mm Bolts	120 in./lb.
5mm Screws	35 in./lb.
6mm Screws	35 in./lb.

APPENDIX

USEFUL FORMULAS AND TABLES

It is often necessary to convert metric to American dimensions or vice versa. This chapter contains formulas for doing so, with typical examples worked out. Also in this chapter are other useful tables and formulas.

CONVERSIONS

Multiply	by	To obtain
Volume		
Cubic centimeters	0.061	Cubic inches
Cubic inches	16.387	Cubic centimeters
Liters	0.264	Gallons
Gallons	3.785	Liters
Liters	1.057	Quarts
Quarts	0.946	Liters
Cubic centimeters	0.0339	Fluid ounces
Fluid ounces	29.57	Cubic centimeters
Length		
Millimeters	0.03937	Inches
Inches	25.4	Millimeters
Centimeters	0.3937	Inches
Inches	2.54	Centimeters
Kilometers	0.6214	Miles
Miles	1.609	Kilometers
Meters	3.281	Feet
Feet	0.3048	Meters
Millimeters	0.10	Centimeters
Centimeters	10.0	Millimeters
Weight		
Kilograms	2.205	Pounds
Pounds	0.4536	Kilograms
Grams	0.03527	Ounces
Ounces	28.35	Grams
Other		
Metric horsepower	1.014	Brake horsepower
Brake horsepower	0.9859	Metric horsepower
Kilogram-meters	7.235	Foot-pounds
Foot-pounds	0.1383	Kilogram-meters
Kilometers per liter	2.352	Miles per gallon
Miles per gallon	0.4252	Kilometers per liter
Square millimeters	0.00155	Square inches
Square inches	645.2	Square millimeters
Square inches	6.452	Square centimeters
Square centimeters	0.155	Square inches
Kilometers per hour	0.6214	Miles per hour
Miles per hour	1.609	Kilometers per hour
Foot-pounds	0.1383	Kilogram-meters
Kilogram-meters	7.233	Foot-pounds
Pounds per square inch	0.0703	Kilograms per square centimeter
Kilograms per square centimeter	14.22	Pounds per square inch
Miles per hour	88	Feet per minute
Feet per minute	0.01136	Miles per hour
Miles per hour	1.467	Feet per second

EXAMPLES OF CONVERSIONS

1. To convert 250 cubic centimeters to cubic inches, multiply 250 cubic centimeters by 0.061:

$$250 \times 0.061 = 15.25 \text{ cubic inches}$$

2. To convert 0.65 inch to millimeters, multiply 0.65 inch by 25.4:

$$0.65 \times 25.4 = 16.51 \text{ millimeters}$$

3. To convert 76 kilograms to pounds, multiply 76 kilograms by 2.205:

$$76 \times 2.205 = 167.58 \text{ pounds}$$

4. To convert 41 miles per gallon to kilometers per liter, multiply 41 miles per gallon by 0.4252:

$$41 \times 0.4252 = 17.43 \text{ kilometers per liter}$$

5. To convert 50 miles per hour to feet per second, multiply 50 miles per hour by 1.467:

$$50 \times 1.467 = 73.35 \text{ feet per second}$$

TEMPERATURE

It is sometimes specified in a service manual to perform a repair operation at a certain temperature, such as heating crankcase halves to 150 degrees C before installing bearings. There are two basic formulas for converting degrees F to degrees C and vice versa:

$$C = 5/9 (F - 32)$$

$$F = 9/5C + 32$$

Example 1

Measurement temperature for the electrolyte in a battery is specified as 68 degrees F. What is that temperature in degrees C?

$$C = 5/9 (F - 32)$$

$$C = 5/9 (68 - 32)$$

$$C = 5/9 \times 36$$

$$C = 180 / 9$$

$$C = 20 \text{ degrees C}$$

Example 2

A motorcycle service manual specifies that main bearings be heated to 200 degrees C before installing them onto the crankshaft. What is that temperature in degrees F?

$$F = 9/5C + 32$$

$$F = (9/5 \times 200) + 32$$

$$F = 360 + 32$$

$$F = 392 \text{ degrees F}$$

PISTON DISPLACEMENT

The formula for finding piston displacement can be expressed as:

$$D = \pi \times R^2 \times S \times N$$

D = Piston displacement

$\pi = 3.14159265359$ (a constant)

S = Piston stroke

N = Number of cylinders

R = Radius of one cylinder (one-half of bore)

(R^2 , read "R squared", means R multiplied by itself)

Example 1

A single cylinder engine has a bore of 70 millimeters, and a stroke of 62 millimeters. What is its displacement?

First convert 70.0 millimeters (bore) and 62.0 millimeters (stroke) to centimeters by dividing each by 10, which is equivalent to multiplying each by 0.10. This step is necessary so that our answer will come out in cubic centimeters. Then using bore and stroke figures expressed in centimeters in the formula:

R = one-half of bore = 3.50

S = 6.20

N = 1

$$D = \pi \times R^2 \times S \times N$$

$$D = 3.1416 \times (3.50)^2 \times 6.20 \times 1$$

$$D = 3.1416 \times 12.25 \times 6.20$$

$$D = 238.6 \text{ cubic centimeters}$$

Example 2

A 3-cylinder engine has a bore of 60.0 millimeters and a stroke of 58.8 millimeters. What is its piston displacement?

First convert both bore and stroke into centimeters by multiplying by 0.10:

R = one-half of bore = 3.0 centimeters

S = 5.88 centimeters

N = 3

$$D = \pi \times R^2 \times S \times N$$

$$D = 3.1416 \times (3.0)^2 \times 5.88 \times 3$$

$$D = 3.1416 \times 9.0 \times 5.88 \times 3$$

$$D = 498.75 \text{ cubic centimeters}$$

Note that the formula will work equally well if bore and stroke are expressed in inches or millimeters. If they are expressed in inches, the answer will come out in cubic inches. The answer will come out in cubic millimeters if millimeters are used in the formula.

COMPRESSION RATIO

To determine compression ratio of an engine, it is first necessary to know piston displacement (of one cylinder) and combustion chamber volume. The formula can be expressed as:

$$\text{Compression ratio} = \frac{\text{Piston displacement} + \text{Combustion chamber vol.}}{\text{Combustion chamber volume}}$$

Example

An engine has a piston displacement of 244.6 cubic centimeters and a combustion chamber volume of 41.5 cubic centimeters. What is its compression ratio?

$$\text{Compression ratio} = \frac{244.6+38.2}{38.2} = \frac{282.8}{38.2} = 7.4 \text{ to } 1 \text{ (rounded off)}$$

HORSEPOWER AND TORQUE

There is sometimes confusion about horsepower and torque. Horsepower is a measure of how much work can be done in a given length of time. One horsepower is equal to the work done when a weight of 550 pounds is lifted one foot in one second, or 33,000 pounds lifted one foot in one minute. Torque is merely twisting force developed by an engine, and is not indicative of how much work can be done, unless engine speed is known. The relationship between horsepower, torque, and engine speed can be expressed as:

$$\text{Horsepower} = \frac{\text{rpm} \times \text{Torque}}{5,252}$$

Example 1

A motorcycle engine develops 30 foot-pounds at 6,000 RPM. How much horsepower does it produce at that speed?

$$= \frac{6,000 \times 30}{5,252} = \frac{180,000}{5,252} = 34.3 \text{ foot-pounds (rounded off)}$$

It is sometimes desired to know how much torque is developed by an engine when horsepower and rpm are known. The formula can then be written as:

$$\text{Torque} = \frac{\text{Horsepower} \times 5,252}{\text{rpm}}$$

Example 2

During a dynamometer test, an engine developed 14.7 horsepower at 3,500 rpm. How much torque did it produce?

$$\text{Torque} = \frac{14.7 \times 5,252}{3,500} = \frac{77,204}{3,500} = 22.06 \text{ foot-pounds (rounded off)}$$

PISTON SPEED

It is at times desirable to know the maximum speed pistons reach as they move in their cylinders. This peak speed is reached when the piston is midway between top dead center and bottom dead center. The formula for finding piston speed is:

$$\text{Piston speed} = \frac{\text{Stroke length (in inches)} \times 2 \times \text{rpm}}{12}$$

Example

An engine has a stroke of 2.5 inches. What is its piston speed at 5,000 rpm?

$$\text{Piston} \quad \frac{2.5 \times 2 \times 5,000}{12} = \frac{25,000}{12}$$

$$\text{Speed} = 12 = 12 = 2,083 \text{ feet per minute}$$

GEAR RATIO

Gear ratio is defined as the number of revolutions a driving gear makes to turn a driven gear through one complete revolution. By convention, a 4 to 1 gear ratio is said to be lower than a 2.5 to 1 ratio. Note that it is possible to have a gear ratio of less than unity. For a pair of gears, the ratio is found by dividing the number of teeth on the driven gear by the number of teeth on the driving gear.

Example 1

There are 27 teeth on the primary drive gear on a certain motorcycle, and 60 teeth on the primary driven gear. What is its primary reduction ratio?

$$\text{Gear ratio} = \frac{\text{Teeth on driven gear}}{\text{Teeth on driving gear}} = \frac{60}{27} = 2.22 \text{ to } 1 \text{ (rounded off)}$$

Example 2

In a certain transmission, there are 27 teeth on 5th input (driving) gear, and 26 teeth on 5th output (driven) gear. What is the gear ratio?

The same formula works equally well for engine and rear wheel sprockets.

$$\text{Gear ratio} = \frac{\text{Teeth on driving gear}}{\text{Teeth on driven gear}} = \frac{27}{26} = 0.96 \text{ to } 1 \text{ (rounded off)}$$

Example 3

There are 15 teeth on the engine sprocket on a certain bike, and 49 teeth on the rear wheel sprocket. What is the final reduction ratio?

$$\text{Reduction ratio} = \frac{\text{Number of teeth on driven sprocket}}{\text{Number of teeth on drive sprocket}} = \frac{49}{15} = 3.27 \text{ to } 1 \text{ (rounded off)}$$

BOLT TORQUE

The following table lists nominal tightening torque for various metric thread sizes:

BOLT TIGHTENING TORQUES

Diameter (Millimeters)	Pitch (Millimeters)	Torque	
		Foot-pounds	(Meter-kilograms)
Coarse thread			
5	0.90	2.53 - 3.47	(0.35 - 0.48)
6	1.00	4.56 - 6.37	(0.63 - 0.88)
8	1.25	11.6 - 15.9	(1.6 - 2.2)
10	1.50	22.4 - 30.4	(3.1 - 4.2)
12	1.75	39.1 - 54.2	(5.4 - 7.5)
14	2.00	60.0 - 83.2	(8.3 - 11.5)
16	2.00	94.0 - 130	(13 - 18)
18	2.50	130 - 181	(18 - 25)
20	2.50	188 - 253	(26 - 35)
Fine thread			
5	0.50	2.53 - 3.47	(0.35 - 0.48)
6	0.75	3.98 - 5.57	(0.55 - 0.77)
8	1.00	9.76 - 13.4	(1.35 - 1.85)
10	1.25	18.4 - 25.3	(2.55 - 3.5)
12	1.50	32.5 - 44.8	(4.5 - 6.2)
14	1.50	53.5 - 73.8	(7.4 - 10.2)
16	1.50	83.2 - 116	(11.5 - 16)
18	1.50	123 - 166	(17 - 23)
20	1.50	166 - 239	(23 - 33)

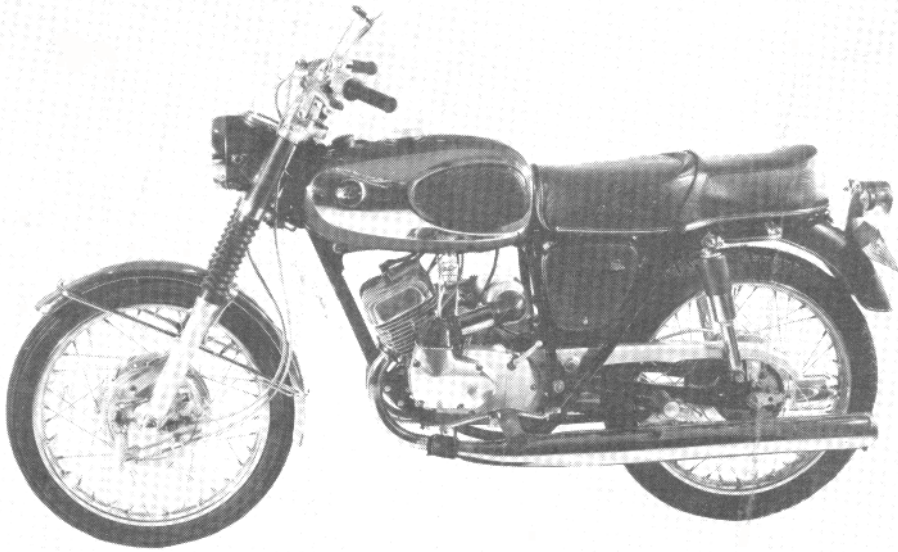

BS175DT

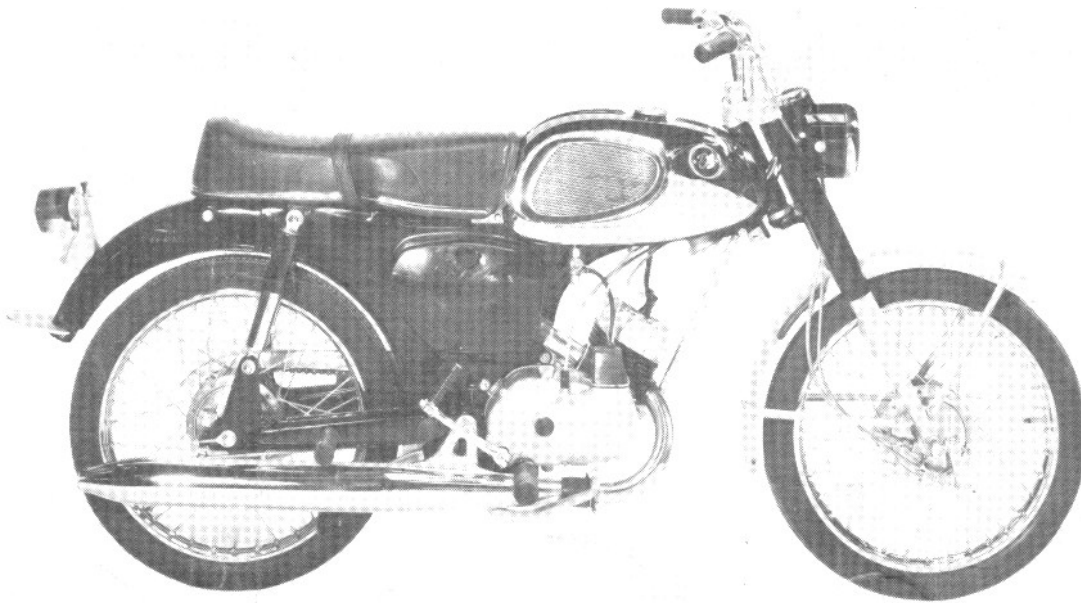

50 Sport

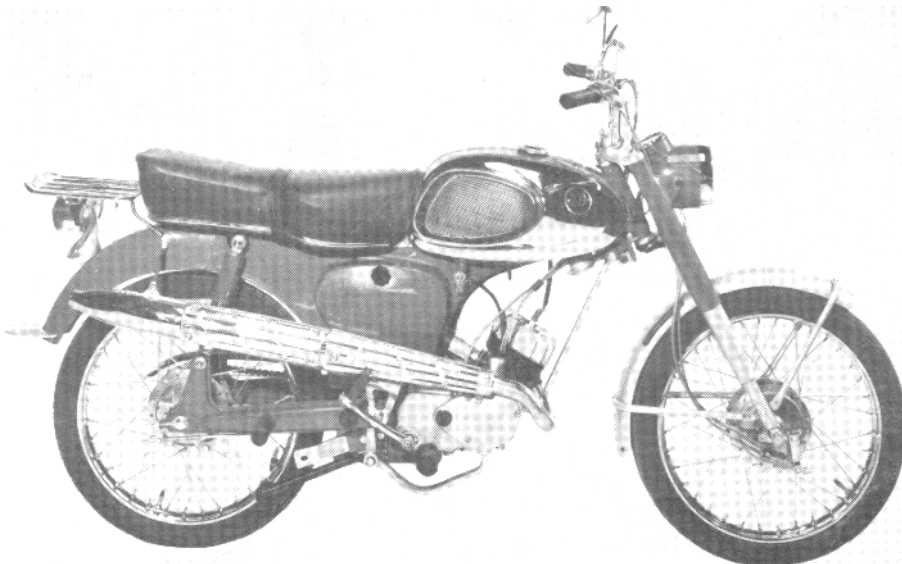

60 Sport

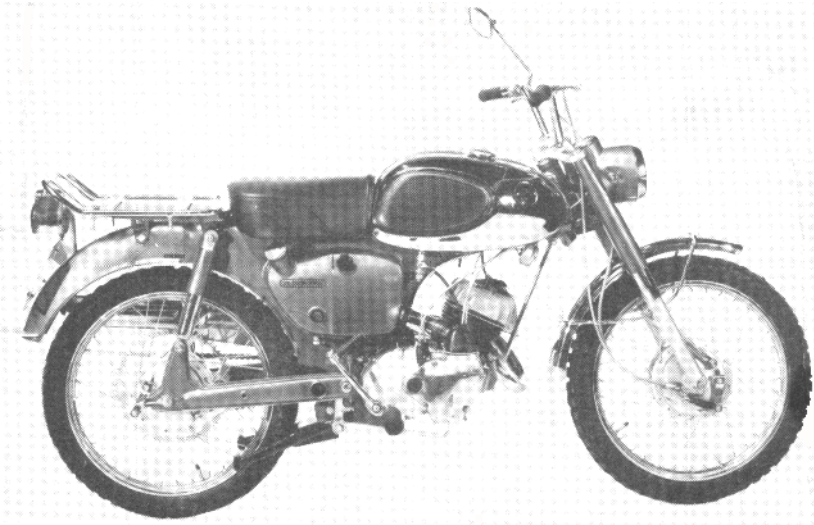

90 Mountain

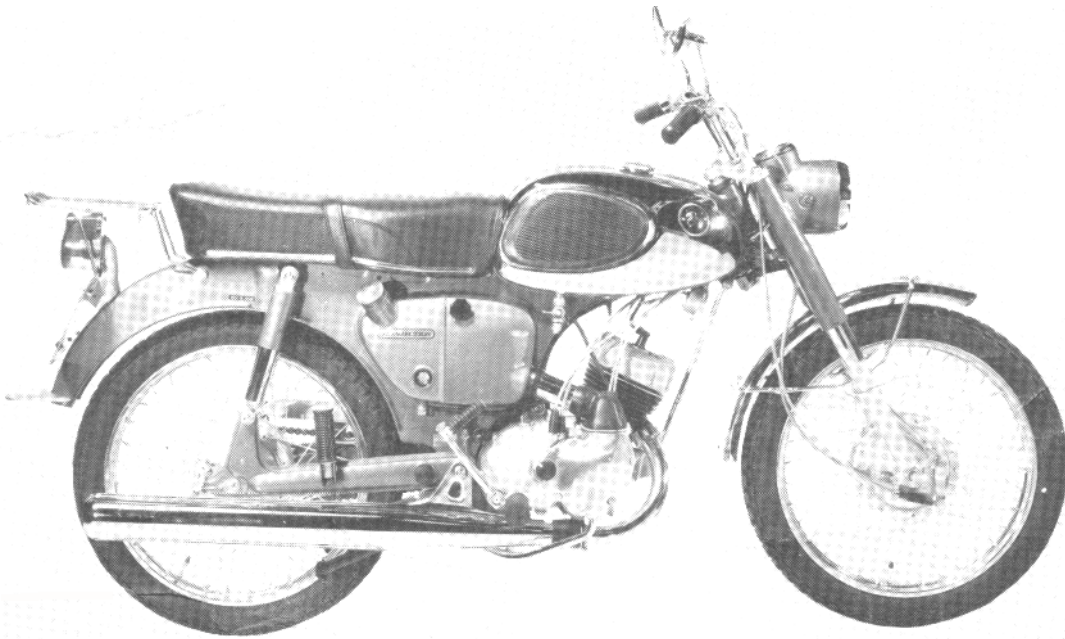

90 Sport

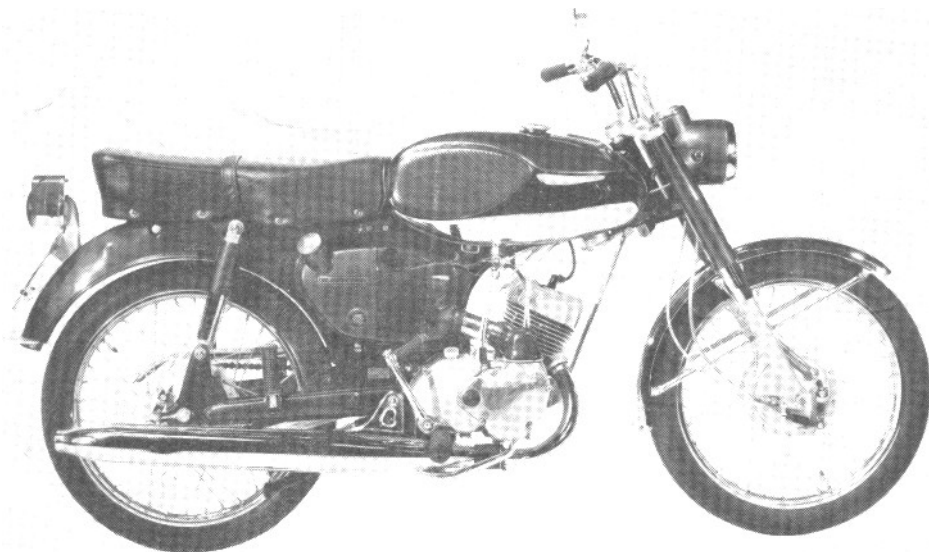

90 Trail