

SKI-DOO

1970-1979

SERVICE • REPAIR • MAINTENANCE

Chapter One General Information	1
Chapter Two Periodic Maintenance and Tune-up	15
Chapter Three Troubleshooting	35
Chapter Four Engine	55
Chapter Five Fuel System	75
Chapter Six Electrical System	95
Chapter Seven Power Train	115
Chapter Eight Front Suspension and Steering	135
Chapter Nine Rear Suspension and Track	155
Chapter Ten Liquid Cooling System	175
Index	195
Wiring Diagrams	215

CONTENTS

QUICK REFERENCE DATA	IX
-----------------------------------	-----------

CHAPTER ONE

GENERAL INFORMATION	1
----------------------------------	----------

Manual organization	Tools
Machine identification and parts replacement	Expendable supplies
Operation	Working safety
Service hints	Snowmobile code of ethics
	Snowmobile safety

CHAPTER TWO

PERIODIC MAINTENANCE AND TUNE-UP	10
---	-----------

Inline fuel filter	Track tension adjustment
Fan belt tension	Slide suspension ride adjustment
Drive and driven pulleys	Hardware and component tightness check
Drive belt	Engine tune-up
Brakes	Off-season storage
Clutch case oil level	

CHAPTER THREE

TROUBLESHOOTING	38
------------------------------	-----------

Operating requirements	Power train
Principles of 2-cycle engines	Drive belt wear analysis
Engine starting	Skis and steering
Engine performance	Track assembly
Engine failure analysis	Track wear analysis
Electrical system	

CHAPTER FOUR
ENGINE **50**

Top end and complete overhaul	Twin cylinder engines
Single cylinder engines	Recoil starter
Component inspection	

CHAPTER FIVE
FUEL SYSTEM **89**

Tillotson carburetor	Fuel filter
Mikuni carburetor	Fuel pump
Air intake silencers	Specifications
Fuel tank	

CHAPTER SIX
ELECTRICAL SYSTEM **110**

CDI system	Lighting system
Magneto ignition	Electric starting system

CHAPTER SEVEN
POWER TRAIN **119**

Drive belt	Chaincase, drive chain, and sprockets
Drive pulley	Brakes
Driven pulley	
Pulley alignment	

CHAPTER EIGHT
FRONT SUSPENSION AND STEERING **138**

Skis	Ski alignment
Steering	

CHAPTER NINE
REAR SUSPENSION AND TRACK **144**

Bogie wheel suspension	Drive axle
Slide suspension	Track
Rear axle	

CHAPTER TEN

LIQUID COOLING SYSTEM 150

- Cooling system
- Draining and filling cooling system
- Radiator removal/installation
- Thermostat removal/installation
- Water pump removal/installation

INDEX 155

WIRING DIAGRAMS END OF BOOK

QUICK REFERENCE DATA

TUNE-UP SPECIFICATIONS

Spark plug gap	0.020 in. (0.51 mm)
Spark plug torque	
14 mm plugs	20 ft.-lb. (2.8 mkg)
18 mm plugs	30 ft.-lb. (4.1 mkg)
Breaker point gap	0.014-0.018 in. (0.35-0.45 mm)

SPARK PLUG APPLICATION

Model	Champion Standard	Bosch Standard
Elan 250, Olympique 300 (299 engine)	K-9	M175T1
Olympique 305, 440 (1973); Olympique 300 (1978)	K-9	M225T1
T'NT F/A, T'NT R/V, T'NT 440 (1973) (14 mm heads) and R/V 340	RM-2	W290M22
Elan 250 Twin and Deluxe to 1977 Olympique 300T, 340, 399, T'NT 399	L-61	W240T1
Olympique 300 Twin (1978 and later), Olympique 340, 340E (1978 and later), Citation 300 (1978 and later), Everest 340, 340E (1978 and later)	L-7B	W280M21
T'NT 340 (1978)	L-7B	W250M21
Blizzard 6500, 7500, 9600	-	W340S28
Blizzard 5500	-	W275T2
Everest 440, 440E; T'NT 440 L/C	K-7	M250T1
Everest 444 L/C	N-3	W280M22 or W280M22 with 2 gaskets
Elan 250SS, 300SS, T'NT 284, 300, 340, Everest 340 (to 1977); Olympique 340 (to 1977); T'NT 292 single; T'NT 440; Everest 440 (to 1977)	L-7B	M280T1

FUEL AND LUBRICATION REQUIREMENTS

Fuel	Regular grade for all except high performance models Premium grade for high performance models
Engine oil type	Ski-Doo 2-cycle oil
Mixture ratio	
1970-1972 models	20:1
1973 models	40:1
1974 and later models	50:1
Rotary valve oil reservoir	Castrol Injector oil
Chaincase oil	Ski-Doo chaincase oil or equivalent (SAE 30)

TRACK TENSION ADJUSTMENT SPECIFICATIONS

Bogie wheel suspension	
1970-1971 models (measured from bottom edge of center bogie wheel to inside edge of track)	2 1/2-3 in. (6.4-7.6 cm)
All other models (measured from top inside edge of track to bottom of footboard)	
Elan	1 1/4-1 1/2 in. (3.2-3.8 cm)
Olympique	2 1/8-2 3/8 in. (5.4-6.0 cm)

(continued)

TRACK TENSION ADJUSTMENT SPECIFICATIONS (continued)

Side suspension	
All models 1970-1973 (measure from footboard to inside track)	5 3/4 in. (14.6-15.2 cm)
1974 and later (measure between bottom of slider shoe and inside of track)	
Ground leveler suspension	1/2-5/8 in. (1.3-1.6 cm)
High performance suspension	5/8 in. (1.6 cm)
Torque reaction suspension	
Olympique; all 1976-1979 models	1/2 in. (1.3 cm)
All other models	3/4 in. (1.9 cm)

IGNITION TIMING SPECIFICATIONS

Engine	Direct Timing BTDC ¹ in. (mm)	Indirect Timing BTDC ¹ in. (mm)
245 (1976)*	0.035-0.065 (0.90-1.40)	N/A
246 (1975)*	0.037-0.067 (0.95-1.45)	N/A
247	0.147-0.167 (3.73-4.23)	N/A ²
248, 249	0.077-0.097 (1.97-2.47)	0.080-0.100 (2.04-2.54)
250	0.150-0.170 (3.81-4.31)	0.150-0.160 (3.81-4.06)
292 (1970-1971)	0.140-0.160 (3.55-4.06)	0.195-0.221 (4.95-5.61)
292, 302 (1972)	0.147-0.167 (3.73-4.23)	0.195-0.215 (4.95-5.46)
294	0.084-0.104 (2.14-2.64)	0.087-0.110 (2.19-2.79)
300	0.150-0.170 (3.81-4.31)	0.205-0.241 (5.20-6.12)
302	0.147-0.167 (3.73-4.23)	0.212-0.244 (5.38-6.20)
305	0.111-0.131 (2.82-3.32)	0.135-0.169 (3.43-4.03)
308, 343 ³ (1975)	0.073-0.093 (1.96-2.36)	0.087-0.107 (2.21-2.71)
335	0.160-0.180 (4.06-4.57)	0.220-0.260 (5.59-6.36)
337	0.157-0.177 (3.99-4.49)	0.229-0.249 (5.81-6.32)
338	0.111-0.131 (2.82-3.32)	0.132-0.154 (3.35-3.89)
340 (1970)	0.160-0.180 (4.06-4.57)	0.198-0.228 (5.02-5.79)
340 (1971)	0.160-0.180 (4.06-4.57)	0.193-0.220 (4.90-5.59)
343 (1972)	0.137-0.157 (3.48-3.98)	0.169-0.179 (4.03-4.55)
343 (1973)	0.111-0.131 (2.82-3.32)	0.131-0.154 (3.33-3.91)
345	0.111-0.131 (2.82-3.32)	0.135-0.159 (3.43-4.03)
345*	0.035-0.066 (0.90-1.40)	N/A
345 (1978)*	0.034-0.054 (0.87-1.37)	N/A
346 (1973)*	0.109-0.129 (2.77-3.28)	N/A
396 (1973)*	0.060-0.080 (1.52-2.03)	N/A
346, 396 (1974)*	0.071-0.091 (1.82-2.32)	N/A
354*, 454*	0.045-0.065 (1.14-1.64)	N/A
399, 440 (1970-1971)	0.160-0.180 (4.06-4.57)	0.148-0.171 (3.76-4.34)
401, 434, 435 (1972)	0.137-0.157 (3.48-3.98)	0.146-0.166 (3.71-4.22)
401	0.111-0.131 (2.82-3.32)	0.135-0.159 (3.43-4.03)
434, 440 ⁴	0.111-0.131 (2.82-3.32)	0.119-0.144 (2.99-3.66)
435	0.111-0.131 (2.82-3.32)	0.119-0.141 (3.02-3.60)
436*	0.071-0.091 (1.82-2.32)	N/A
440 (1975)*	0.071-0.091 (1.82-2.32)	0.077-0.097 (1.96-2.46)
440 (1978-1979)	0.111-0.131 (2.82-3.32)	0.120-0.140 (3.05-3.55)
444	0.082-0.102 (2.10-2.60)	N/A
503	0.088-0.088 (1.82-2.32)	N/A

*Engines equipped with CDI.

1. Use direct timing for engines with vertical spark plug holes and indirect timing for engines with spark plug on an angle.

2. On 1972 models, indirect specification is the same as direct.

3. On 343 engines serial number 3,019,645 to 3,020,644 direct timing is 0.147-0.167 in. (3.73-4.23 mm).

4. Except 1975 440 with CDI.



CHAPTER ONE

GENERAL INFORMATION

Snowmobiling has in recent years become one of the most popular outdoor winter recreational pastimes. It provides an opportunity for an entire family to experience the splendor of winter and enjoy a season previously regarded by many as miserable.

Snowmobiles also provide an invaluable service in the form of rescue and utility vehicles in areas that would otherwise be inaccessible.

As with all sophisticated pieces of machinery, snowmobiles require specific periodic maintenance and repair to ensure their reliability and usefulness.

MANUAL ORGANIZATION

This manual provides periodic maintenance, tune-up, and general repair procedures for Ski-Doo snowmobiles manufactured since 1970.

This chapter provides general information and hints to make all snowmobile work easier and more rewarding. Additional sections cover snowmobile operation, safety, and survival techniques.

Chapter Two provides all tune-up and periodic maintenance required to keep your snowmobile in top running condition.

Chapter Three provides numerous methods and suggestions for finding and fixing troubles

fast. The chapter also describes how a 2-cycle engine works, to help you analyze troubles logically. Troubleshooting procedures discuss typical symptoms and logical methods to pinpoint the trouble.

Subsequent chapters describe specific systems such as engine, fuel system, and electrical system. Each provides disassembly, repair, and reassembly procedures in easy-to-follow, step-by-step form. If a repair is impractical for the owner/mechanic, it is so indicated. Usually, such repairs are quicker and more economically done by a Ski-Doo dealer or other competent snowmobile repair shop.

Some of the procedures in this manual specify special tools. In all cases, the tool is illustrated in actual use or alone.

The terms **NOTE**, **CAUTION**, and **WARNING** have specific meaning in this book. A **NOTE** provides additional information to make a step or procedure easier or clearer. Disregarding a **NOTE** could cause inconvenience, but would not cause damage or personal injury.

A **CAUTION** emphasizes areas where equipment damage could result. Disregarding a **CAUTION** could cause permanent mechanical damage; however, personal injury is unlikely.

A **WARNING** emphasizes areas where personal injury or death could result from negligence.

Mechanical damage may also occur. **WARNINGS** are to be taken seriously. In some cases, serious injury or death has been caused by mechanics disregarding similar warnings.

MACHINE IDENTIFICATION AND PARTS REPLACEMENT

Each snowmobile has a serial number applicable to the machine and a model and serial number for the engine.

Figure 1 shows the location of the machine serial number on the right side of the tunnel. **Figure 2** shows the location of engine model and serial numbers.



Write down all serial and model numbers applicable to your machine and carry the numbers with you. When you order parts from a dealer, always order by year and engine and machine numbers. If possible, compare old parts to the new ones before purchasing them. If parts are not alike, have the parts manager explain the difference.

OPERATION

Fuel Mixing

WARNING

Serious fire hazards always exist around gasoline. Do not allow any smoking in areas where fuel is mixed or when refueling your snowmobile.

Always use fresh fuel. Gasoline loses its potency after sitting for a period of time. Old fuel can cause engine failure and leave you stranded in severe weather.

Proper fuel mixing is very important for the life and efficiency of the engine. All engine lubrication is provided by the oil mixed with the gasoline. Always mix fuel in exact proportions. A "too lean" mixture can cause serious and expensive damage. A "too rich" mixture can cause poor performance and fouled spark plugs which can make an engine difficult or impossible to start.

Use a gasoline with an octane rating of 90 or higher. Use premium grade gasoline in all high performance racing machines. Mix gasoline in a separate tank, not the snowmobile fuel tank. Use a tank with a larger volume than necessary to allow room for the fuel to agitate and mix completely.

Use Ski-Doo Snowmobile oil and mix with fresh gasoline in a 20:1 ratio for 1970-1973 models, 40:1 for 1974 models and 50:1 for all later models.

1. Pour required amount of oil into a clean container.
2. Add $\frac{1}{2}$ the necessary gasoline and mix thoroughly.
3. Add remainder of gasoline and mix entire contents thoroughly.
4. Always use a funnel equipped with a fine screen while adding fuel to the snowmobile.

Pre-start Inspection

1. Familiarize yourself with your machine, the owner's manual, and all decals on the snowmobile.
2. Clean the windshield with a clean, damp cloth. *Do not* use gasoline, solvents, or abrasive cleaners.

3. Check all ski and steering components for wear and loose parts. Correct as necessary.
4. Check track tension.
5. Check operation of throttle and brake controls and ensure that they are free and properly adjusted.
6. Check fuel level.

WARNING

Before starting engine, be sure no bystanders are in front of, or behind, the snowmobile or a sudden lurch may cause serious injuries.

7. Start engine and test operation of emergency kill switch. Check that all lights are working.

Emergency Starting

Always carry a small tool kit with you. Carry an extra starting rope for emergency starting or use the recoil starter rope.

1. Remove hood.
2. Remove recoil starter.
3. Wind rope around starter pulley and pull to crank engine.

Emergency Stopping

To stop the engine in case of an emergency, switch emergency kill switch to stop or off position.

Towing

When preparing for a long trip, pack extra equipment in a sled, do not try to haul it on the snowmobile. A sled is also ideal for transporting small children.

WARNING

Never tow a sled with ropes or pull straps, always use a solid tow bar. Use of ropes or flexible straps could result in a fallpipe accident, when the snowmobile is stopped, with subsequent serious injury.

If it is necessary to tow a disabled snowmobile, securely fasten the disabled machine's skis to the hitch of the tow machine. Remove the drive belt from the disabled machine before towing.

Clearing the Track

If the snowmobile has been operated in deep or slushy snow, it is necessary to clear the track after stopping or the track may freeze, making starting the next time difficult.

WARNING

Always be sure no one is behind the machine when clearing the track. Ice and rocks thrown from the track can cause serious injury.

Tip the snowmobile on its side until the track clears the ground *completely*. Run the track at a moderate speed until all the ice and snow is thrown clear.

CAUTION

If track does freeze, it must be broken loose manually. Attempting to force a frozen track with the engine running will burn and damage the drive belt.

Proper Clothing

Warm and comfortable clothing are a must to provide protection from frostbite. Even mild temperatures can be very uncomfortable and dangerous when combined with a strong wind or when traveling at high speed. See **Table 1** for wind chill factors. Always dress according to what the wind chill factor is, not the temperature. Check with an authorized dealer for suggested types of snowmobile clothing.

WARNING

To provide additional warmth as well as protection against head injury, always wear an approved helmet when snowmobiling.

SERVICE HINTS

All procedures described in this book can be performed by anyone reasonably handy with tools. Special tools are required for some procedures; their operation is described and illustrated. These may be purchased at Ski-Doo dealers. If you are on good terms with the dealer's service department, you may be able to borrow from them, however, it should be borne in mind that many of these tools will pay for



Table 1 WIND CHILL FACTORS

Estimated Wind Speed in MPH	Actual Thermometer Reading (° F)											
	50	40	30	20	10	0	-10	-20	-30	-40	-50	-60
	Equivalent Temperature (° F)											
Calm	50	40	30	20	10	0	-10	-20	-30	-40	-50	-60
5	48	37	27	16	5	-5	-15	-26	-36	-47	-57	-68
10	40	28	16	4	-9	-21	-33	-46	-58	-70	-83	-95
15	36	22	9	-5	-18	-36	-45	-58	-72	-85	-99	-112
20	32	18	4	-10	-25	-39	-53	-67	-82	-96	-110	-124
25	30	16	0	-15	-29	-44	-59	-74	-88	-104	-118	-133
30	28	13	-2	-18	-33	-48	-63	-79	-94	-109	-125	-140
35	27	11	-4	-20	-35	-49	-67	-82	-98	-113	-129	-145
40	26	10	-6	-21	-37	-53	-69	-85	-100	-116	-132	-148
*	Little Danger (for properly clothed person)			Increasing Danger				Great Danger				
	* Danger from freezing of exposed flesh *											
*Wind speeds greater than 40 mph have little additional effect.												

themselves after the first or second use. If special tools are required, make arrangements to get them before starting. It is frustrating and sometimes expensive to get under way and then find that you are unable to finish up.

Service will be far easier if the machine is clean before beginning work. There are special cleaners for washing the engine and related parts. Just brush or spray on the cleaning solution, let it stand, then rinse it away with a garden hose. Clean all oily or greasy parts with cleaning solvent as they are removed.

WARNING

Never use gasoline as a cleaning agent, as it presents an extreme fire hazard. Be sure to work in a well-ventilated area when using cleaning solvent. Keep a fire extinguisher handy, just in case.

Observing the following practices will save time, effort, and frustration as well as prevent possible expensive damage:

1. Tag all similar internal parts for location and mark all mating parts for position. Small parts such as bolts can be identified by placing them in plastic sandwich bags and sealing and labeling the bags with masking tape.
2. Frozen or very tight bolts and screws can often be loosened by soaking them with penetrating oil such as WD-40[®], then sharply striking the bolt head a few times with a hammer and punch (or screwdriver for screws). A hammer driven impact tool can also be very effective. However, ensure tool is seated squarely on the bolt or nut before striking. Avoid heat unless absolutely necessary, since it may melt, warp, or remove the temper from many parts.
3. Avoid flames or sparks when working near flammable liquids such as gasoline.
4. No parts, except those assembled with a press fit, require unusual force during assembly. If a part is hard to remove or install, find out why before proceeding.
5. Cover all openings after removing parts to keep dirt, small tools, etc., from falling in.
6. Clean all parts as you go along and keep them separated into subassemblies. The use of trays, jars, or cans will make reassembly that much easier.
7. Make diagrams whenever similar-appearing parts are found. You may *think* you can remember where everything came from — but mistakes are costly. There is also the possibility you

may be sidetracked and not return to work for days or even weeks — in which interval carefully laid out parts may have become disturbed.

8. Wiring should be tagged with masking tape and marked as each wire is removed. Again, do not rely on memory alone.

9. When reassembling parts, be sure all shims and washers are replaced exactly as they came out. Whenever a rotating part butts against a stationary part, look for a shim or washer. Use new gaskets if there is any doubt about the condition of old ones. Generally, you should apply gasket cement to only one mating surface so the parts may be easily disassembled in the future. A thin coat of oil on gaskets helps them seal effectively.

10. Heavy grease can be used to hold small parts in place if they tend to fall out during assembly. However, keep grease and oil away from electrical and brake components.

11. High spots may be sanded off a piston with sandpaper, but emery cloth and oil do a much more professional job.

12. Carburetors are best cleaned by disassembling them and soaking the parts in a commercial carburetor cleaner. Never soak gaskets and rubber parts in these cleaners. Never use wire to clean out jets and air passages; they are easily damaged. Use compressed air to blow out the carburetor only if the float has been removed first.

13. Take your time and do the job right. Do not forget that a newly rebuilt snowmobile engine must be broken in the same as a new one. Keep rpm's within the limits given in your owner's manual when you get back on the snow.

14. Work safely in a good work area with adequate lighting and allow sufficient time for a repair task.

15. When assembling 2 parts, start all fasteners, then tighten evenly.

16. Before undertaking a job, read the entire section in this manual which pertains to it. Study the illustrations and text until you have a good idea of what is involved. Many procedures are complicated and errors can be disastrous. When you thoroughly understand what is to be done, follow the prescribed procedure step-by-step.

TOOLS

Every snowmobiler should carry a small tool kit to help make minor adjustments as well as perform emergency repairs.

A normal assortment of ordinary hand tools is required to perform the repair tasks outlined in this manual. The following list represents the minimum requirement:

- a. American and metric combination wrenches
- b. American and metric socket wrenches
- c. Assorted screwdrivers
- d. Pliers
- e. Feeler gauges
- f. Spark plug wrench
- g. Small hammer
- h. Plastic or rubber mallet
- i. Parts cleaning brush

When purchasing tools, always get quality tools. They cost more initially but in most cases will last a lifetime. Remember, the initial expense of new tools is easily offset by the money saved on a few repair jobs.

Tune-up and troubleshooting require a few special tools. All of the following special tools are used in this manual, however all tools are not necessary for all machines. Read the procedures applicable to your machine to determine what your special tool requirements are.

1. *Ignition gauge* (Figure 3). This tool combines round wire spark plug gap gauges with narrow breaker point feeler gauges. The device costs about \$3 at auto accessory stores.

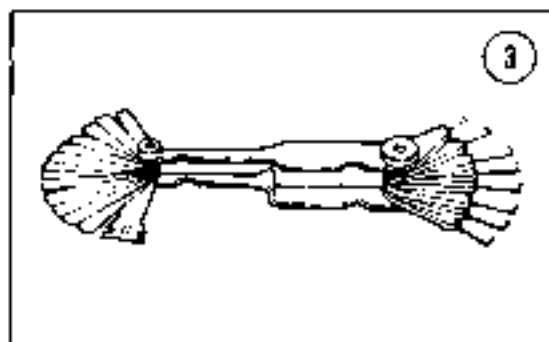

2. *Impact driver* (Figure 4). This tool might have been designed with the snowmobiler in mind. It makes removal of screws easy, and

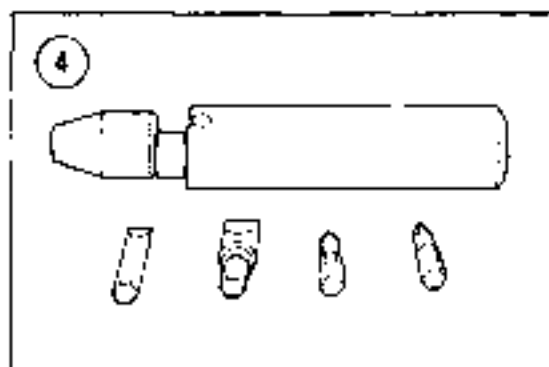

eliminates damaged screw slots. Good ones can about \$12 at larger hardware stores.

3. *Hydrometer* (Figure 5). This instrument measures state of charge of the battery, and tells much about battery condition. Such an instrument is available in any auto parts store and through most larger mail order outlets. Satisfactory ones cost as little as \$3.

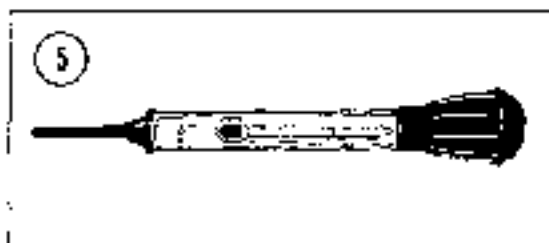

4. *Multimeter or vsm* (Figure 6). This instrument is invaluable for electrical system troubleshooting and service. A few of its functions may be duplicated by locally fabricated substitutes, but for the serious hobbyist, it is a must. Its uses are described in the applicable sections of this book. Prices start at around \$10 at electronics hobbyists stores and mail order outlets.

5. *Timing gauge* (Figure 7). This device is used to precisely locate the position of the piston before top dead center to achieve the most accurate ignition timing. The instrument is screwed into the spark plug hole and indicates inches and/or millimeters. The tool shown costs about \$20 and is available from most dealers and mail order houses. Less expensive tools, which use a vernier scale instead of a dial indicator, are also available.

6. *Air flow meter or carburetor synchronizer* (Figure 8). This device is used on engines with

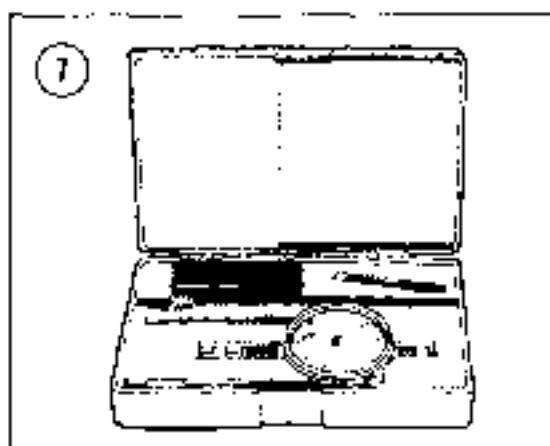
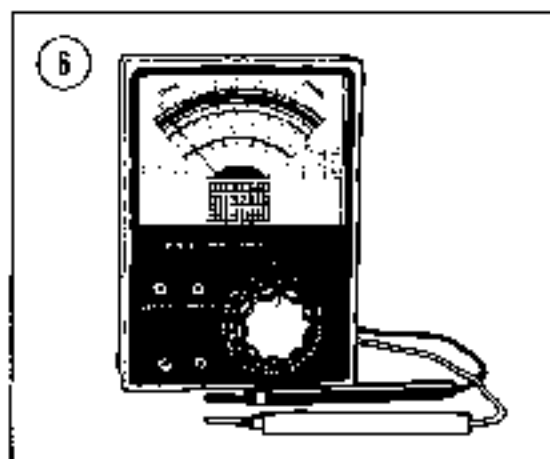

multiple carburetors to line tune the synchronization and idle speed. The tool shown costs about \$10-15 at most dealers, auto parts stores, and mail order houses.

7. *Compression gauge* (Figure 9). The compression gauge measures the compression pressure built up in each cylinder. The results, when properly interpreted, indicate general piston, cylinder, ring, and head gasket condition. Gauges are available with, or without, the flexible hose. Prices start around \$5 at most auto parts stores and mail order outlets.

EXPENDABLE SUPPLIES

Certain expendable supplies are also required. These include grease, oil, gasket cement, wiping rags, cleaning solvent, and distilled water. Solvent is available at many service stations. Distilled water, required for the battery,

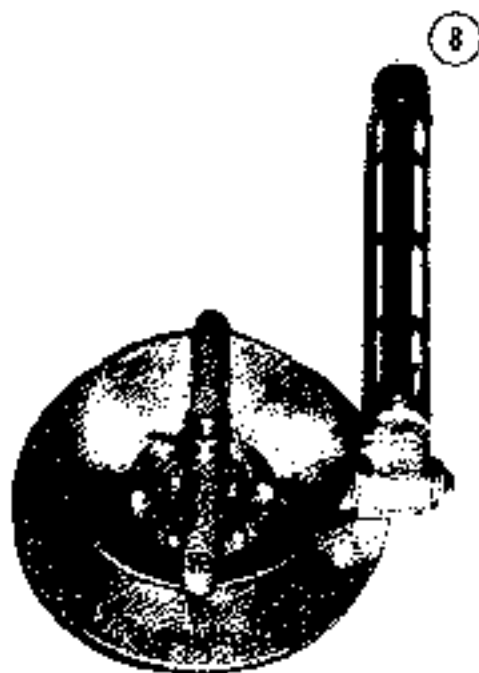

own machine. You can also hurt yourself or damage the machine if you ignore these rules.

1. Never use gasoline as a cleaning solvent.
2. Never smoke or use a torch in the area of flammable liquids, such as cleaning solvent in open containers.
3. Never smoke or use a torch in an area where batteries are charging. Highly explosive hydrogen gas is formed during the charging process.
4. If welding or brazing is required on the machine, remove the fuel tank to a safe distance, at least 50 feet away.
5. Be sure to use properly sized wrenches for nut turning.
6. If a nut is tight, think for a moment what would happen to your hand should the wrench slip. Be guided accordingly.
7. Keep your work area clean and uncluttered.
8. Wear safety goggles in all operations involving drilling, grinding, or use of a chisel.
9. Never use worn tools.
10. Keep a fire extinguisher handy. Be sure it is rated for gasoline and electrical fires.

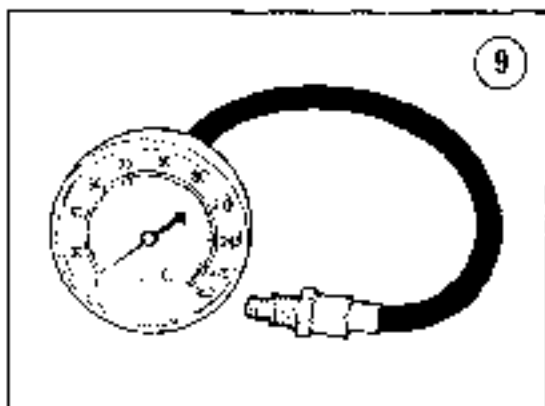

is available at every supermarket. An increasing number of mechanics clean oily parts with a solution of common household detergent or laundry powder.

WORKING SAFELY

Professional mechanics can work for years without sustaining serious injury. If you observe a few rules of common sense and safety, you can enjoy many safe hours servicing your

SNOWMOBILE CODE OF ETHICS

When snowmobiling, always observe the following code of ethics as provided by the International Snowmobile Industry Association.

1. I will be a good sportsman. I recognize that people judge all snowmobile owners by my actions. I will use my influence with other snowmobile owners to promote sportsmanlike conduct.
2. I will not litter trails or camping areas. I will not pollute streams or lakes.
3. I will not damage living trees, shrubs, or other natural features.
4. I will respect other people's property and rights.
5. I will lend a helping hand when I see someone in distress.
6. I will make myself and my vehicle available to assist search and rescue parties.
7. I will not interfere with or harass hikers, skiers, snowshoers, ice fishermen, or other winter sportsmen. I will respect their rights to enjoy our recreation facilities.

8. I will snow and obey all federal, state, and local rules regulating the operation of snowmobiles in areas where I use my vehicle. I will inform public officials when using public lands.
9. I will not harass wildlife. I will avoid areas posted for the protection or feeding of wildlife.
10. I will stay on marked trails or marked roads open to snowmobiles. I will avoid country travel unless specifically authorized.
11. Never attempt to repair your machine while the engine is running.
12. Check all machine components and hardware frequently, especially skis and steering.
13. Never lift rear of machine to clear the track. Tip machine on its side and be sure no one is behind machine.
14. Winch snowmobile onto a flat-bed trailer, never drive it on. Secure machine firmly to trailer and ensure trailer lights operate.

SNOWMOBILE SAFETY

General Tips

1. Read your owner's manual and know your machine.
2. Check throttle and brake controls before starting the engine. Frozen controls can cause serious injury.
3. Know how to make an emergency stop.
4. Know all state, provincial, federal, and local laws concerning snowmobiling. Respect private property.
5. Never add fuel while smoking or when engine is running. Always use fresh, properly mixed fuel. Improper fuel mixtures can cause engine failure, and can leave you stranded in severe weather.
6. Wear adequate clothing to avoid frostbite. Never wear any loose scarves or belts that could catch in moving parts or on tree limbs.
7. Wear eye and head protection. Wear tinted goggles or face shields to guard against snow-blindness. Never wear yellow eye protection.
8. Never allow anyone to operate the snowmobile without proper instruction.
9. Use the "huddy system" for long trips. A snowmobile travels farther in 30 minutes than you can walk in a day.
10. Take along sufficient tools and spare parts for emergency field repairs.
11. Use a sled with a stiff tow bar for carrying extra supplies. Do not overload your snowmobile.
12. Carry emergency survival supplies when going on long trips. Notify friends and relatives of your destination and expected arrival time.
13. Never operate the vehicle in crowded areas, or steer toward persons.
14. Avoid avalanche areas and other unsafe terrain.
15. Cross highways (where permitted) at a 90 degree angle after looking in both directions. Post traffic guards if crossing in groups.
16. Do not ride snowmobile on or near railroad tracks. The snowmobile engine can drown out the sound of an approaching train. It is difficult to maneuver the snowmobile from between the tracks.
17. Do not ride snowmobile on ski slope areas with skiers.
18. Always check the thickness of the ice before riding on frozen lakes or rivers. Do not panic if you go through ice; conserve energy.
19. Keep headlight and taillight areas free of snow and never ride at night without lights.
20. Do not ride snowmobile without shields, guards, and protective hoods.
21. Do not attempt to open new trails at night. Follow established trails or unseen barbed wire or city wires may cause serious injury or death.
22. Always steer with both hands.
23. Be aware of terrain and avoid operating snowmobile at excessive speed.
24. Do not panic if throttle sticks. Pull "rether" string or push emergency stop switch.
25. Drive more slowly when carrying a passenger, especially a child.
26. Always allow adequate stopping distance based on ground cover conditions. Ice requires a greater stopping distance to avoid skidding. Apply brakes gradually on ice.

15. Do not speed through wooded areas. Hidden obstructions, hanging limbs, unseen ditches, and even wild animals can cause accidents.
16. Do not tailgate. Rear end collisions can cause injury and machine damage.
17. Do not mix alcoholic beverages with snowmobiling.
18. Keep feet on footrests at all times. Do not permit feet to hang over sides or attempt to stabilize machine with feet when making turns or in near-spill situations; broken limbs could result.
19. Do not stand on seat, stunt, or show off.
20. Do not jump snowmobile. Injury or machine damage could result.
21. Always keep hands and feet out of the track area when engine is running. Use extra care when freeing snowmobile from deep snow.
22. Check fuel supply regularly. Do not travel further than you fuel will permit you to return.
23. Whenever you leave your machine unattended, remove the "lather" switch.

Preparing for a Trip

1. Check all bolts and fasteners for tightness. Do not operate your snowmobile unless it is in top operating condition.
2. Check weather forecasts before starting out on a trip. Cancel your plans if a storm is possible.
3. Study maps of the area before the trip and know where help is located. Note locations of phones, resorts, shelters, towns, farms, and ranches. Know where fuel is available. If possible, use the buddy system.
4. Do not overload your snowmobile. Use a sled with a stiff tow bar to haul extra supplies.
5. Do not risk a heart attack if your snowmobile gets stuck in deep snow. Carry a small block and tackle for such situations. Never allow anyone to manually pull on the skis while you attempt to drive machine out.
6. Do not ride beyond one-half the round trip cruising range of your fuel supply. Keep in mind how far it is home.
7. Always carry emergency survival supplies when going on long trips or traveling in unknown territory. Notify friends and relatives of your destination and expected arrival time.
8. Carry adequate eating and cooking utensils (small pans, kettle, plates, cups, etc.) on longer trips. Carry matches in a waterproof container, candles for building a fire, and easy-to-pack food that will not be damaged by freezing. Carry dry food or space energy sticks for emergency rations.
9. Pack extra clothing, a tent, sleeping bag, hand axe, and compass. A first aid kit and snow shoes may also come in handy. Space age blankets (one side silverfoil) furnish warmth and can be used as heat reflectors or signaling devices for aerial search parties.

Emergency Survival Techniques

1. Do not panic in the event of an emergency. Relax, think the situation over, then decide on a course of action. You may be within a short distance of help. If possible, repair your snowmobile so you can drive to safety. Conserve your energy and stay warm.
2. Keep hands and feet active to promote circulation and avoid frostbite while servicing your machine.
3. Mentally retrace your route. Where was the last point where help could be located? Do not attempt to walk long distances in deep snow. Make yourself comfortable until help arrives.
4. If you are properly equipped for your trip you can turn any undesirable area into a suitable campsite.
5. If necessary, build a small shelter with tree branches or evergreen boughs. Look for a cave or sheltered area against a hill or cliff. Even burrowing in the snow offers protection from the cold and wind.
6. Prepare a signal fire using evergreen boughs and snowmobile oil. If you cannot build a fire, make an S-O-S in the snow.
7. Use a policeman's whistle or heat cooking utensils to attract attention or frighten off wild animals.
8. When your camp is established, climb the nearest hill and determine your whereabouts. Observe landmarks on the way, so you can find your way back to your campsite. Do not rely on your footprints. They may be covered by blowing snow.

CHAPTER TWO

PERIODIC MAINTENANCE AND TUNE-UP

To gain the utmost in safety, performance, and useful life from your machine, it is necessary to make periodic inspections and adjustments. It frequently happens that minor problems are found during such inspections that are simple and inexpensive to correct at the time, but which could lead to major problems later.

This chapter includes routine maintenance and inspections as well as complete tune-up procedures for all models. Table 1 summarizes this important information. Keep detailed records of inspections, adjustments, and tune-ups. Such records can help identify recurring trouble areas as well as ensure that required maintenance and tune-up items are accomplished as recommended by the manufacturer.

INLINE FUEL FILTER

Replace the inline fuel filter at the beginning of each season's operation. Examine the filter periodically as specified in Table 1 and replace it if there is evidence of fuel line contamination.

FAN BELT TENSION

Check fan belt tension at specified intervals (Table 1).

1. Remove the fan cover and recoil starter mechanism.

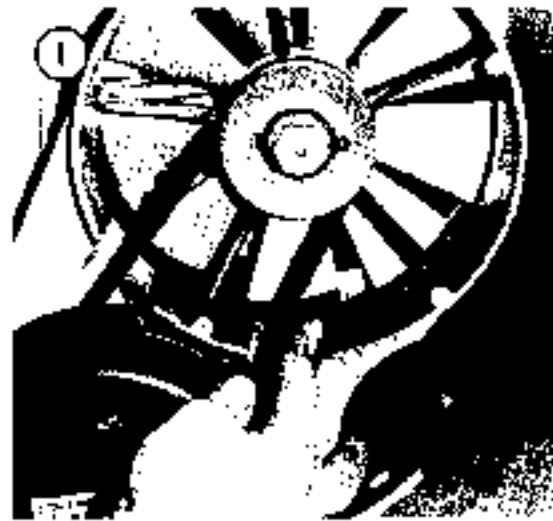

2. Deflect belt with your fingers as shown in Figure 1. Examine belt for signs of fraying or deterioration. Adjust belt if deflection is more than $\frac{1}{4}$ in. (6mm) as outlined under *Fan Belt Adjustment*, Chapter Four. Replace belt if necessary.

DRIVE AND DRIVEN PULLEYS

All drive and driven pulleys should be removed, disassembled, cleaned, and inspected for worn parts annually. The majority of work on

Table 1 SCHEDULED MAINTENANCE

Check the following items at indicated intervals:	Annually	Monthly (or 40 hrs. operation)	Weekly (or 10 hrs. operation)	Daily
Windshield	X	X	X	X
Condition of skis and steering components	X	X	X	X
Track condition and tension	X	X	X	X
Throttle control	X	X	X	X
Brake	X	X	X	X
Emergency stop switch	X	X	X	X
Lighting system	X	X	X	X
Chaincase oil level	X	X	X	
In-line filter for contamination	X	X	X	
Drive belt	X	X	X	
Carburetor adjustments	X	X		
Ski alignment	X	X		
Fan belt tension	X	X		
Headlight adjustment	X	X		
Ski runner shoes	X	X		
Slide suspension wear bars	X	X		
All components for condition and tightness	X			
Drive and driven pulleys	X			

these components requires special tools and expertise. Refer to Chapter Seven for work you can perform. Refer all other work to an authorized dealer.

DRIVE BELT

Examine drive belt periodically as specified in Table 1. If belt shows unusual signs of wear, refer to Chapter Three for drive belt analysis and troubleshooting. Replace drive belt if its width is reduced by $\frac{1}{8}$ in. (3mm). Refer to Chapter Seven for standard width and drive belt replacement for your model. Drive belts are not interchangeable between different models even though belt width may be the same.

Removal/Installation

Refer to Figure 2 for this procedure.

1. Tilt cab and remove pulley guard.

2. Twist and push sliding half of driven pulley to open pulley.

3. Hold pulley in open position and slip drive belt off of driven pulley and then off the drive pulley.

CAUTION

Do not pry belt off over pulleys or belt and/or pulleys may be damaged.

4. Installation is the reverse of these steps. Check drive belt tension as outlined in Chapter Seven.

BRAKES

Check brake operation as scheduled in Table 1. Brakes are operating properly if the track is locked when the brake control lever is the specified distance from handlebar grip. If brake control lever movement is excessive, perform brake adjustment.

Brake Adjustment (Bombardier Self-Adjusting Disc)

1. Rotate cable, adjusting nuts until no free play exists between brake lever and brake housing on handlebar.
2. Measure gap between brake lever and brake caliper. Gap should be $2 \pm \frac{1}{4}$ in. (50 ± 3 mm) on floating caliper type and $1\frac{1}{2} \pm \frac{1}{4}$ in. (38 ± 3 mm) on floating disc type (Figure 3). On Blizzard 5500 models, gap should be $2\frac{1}{4} \pm \frac{1}{4}$ in. (57 ± 3 mm). Rotate adjuster nut until specified dimension is achieved.

NOTE: On floating caliper type it may be necessary to move brake light switch support to achieve specified gap.

3. Check operation of brake light and loosen and adjust light switch locknuts if necessary (Figure 4).

Brake Adjustment (Except Bombardier Self-Adjusting Disc)

1. Firstly apply brake and measure distance between brake control lever and handlebar grip. Distance should be as follows:
 - a. Pivot brake and 1970-1971 drum brakes, $\frac{1}{4}$ in. (6.4mm).
 - b. All drum and disc except self-adjusting disc, 1 in. (25mm).
 - c. Self-adjusting disc, $\frac{1}{2}$ in. (13mm).
2. If distance between brake lever and handlebar grip is excessive, loosen locknuts on brake cable and adjust cable for specified dimension (Figure 5).
3. Tighten brake cable locknuts and recheck. Readjust if necessary.
4. Check operation of brake light and loosen and adjust light switch locknuts if necessary (Figure 6).

Hydraulic Disc Brake Bleeding

Check that fluid level is within $\frac{1}{4}$ in. (3.2mm) from the top of master cylinder reservoir. Use only brake fluid specified SAE 70R3, DOT 3, or DOT 4 for automotive disc brake application.

If brake work has been performed or if brake operation is "spongy," bleeding may be necessary to expel any air from the system.



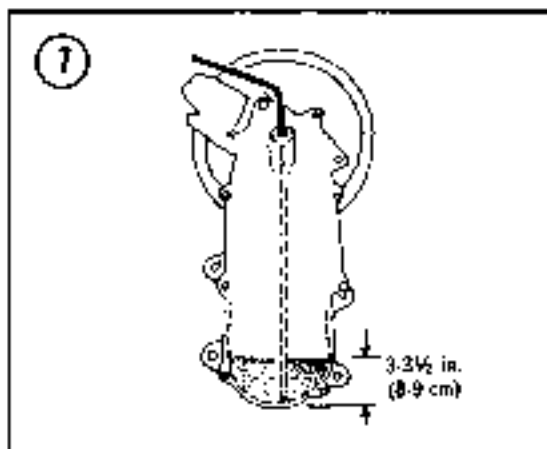

NOTE: During bleeding operation, be sure master cylinder reservoir is kept topped up to the specified level. If level is allowed to drop too low, air may be ingested, requiring complete rebleeding.

1. Connect a plastic or rubber hose to brake bleeder nipple. Place other end of hose in a container with a few inches of clean brake fluid. Keep hose end below the level of the brake fluid.
2. Open brake bleed valve slightly.
3. Operate brake lever and note air bubbles released in jar. Continue operating brakes until all air is expelled. Be sure to keep master cylinder level topped off.
4. After all air has been expelled, close bleeder valve while slowly squeezing brake lever. Check all connections for leaks and remove bleeder hose.

CAUTION

Do not use brake fluid from bleed jar to top off reservoir as the fluid is already aerated.

CHAINCASE OIL LEVEL

Check level of chaincase oil at intervals specified in **Table 1** earlier in this chapter.

NOTE: On models where oil level is difficult to see, because of tool box, use a long piece of stiff wire as a dipstick and measure oil level through filler hole (Figure 7). Ensure that dipstick touches bottom of chaincase. Oil level should be 3-3 1/2 in. (8-9 cm).

On machines with pressed steel chaincase and aluminum chaincase (without external tension adjuster) oil level should be flush with indicator level or plug (Figure 8).

On models with aluminum chaincase with external tension adjuster, total quantity of oil is 6 oz. (180cc).

On later model Blizzards oil level should be to bottom of the oil level opening as shown in Figure 9.

Top off oil level if necessary with SKI-DOO chaincase oil or equivalent (SAE 30).

Use a syringe or oil suction device to remove old oil when changing oil for machine storage preparation.



Rotary Valve Oil Reservoir

Check level of oil in reservoir frequently on rotary valve models. Do not allow oil level to fall below line on reservoir as shown in Figure 10. Top off reservoir with Castrol Injector Oil.

Liquid Coolant Level

Coolant level should be 1 in. (25mm) below filler neck of coolant tank. Start engine and run at least one minute after thermostat opens: 110 F (43°C). Stop engine and check coolant level. Top up if necessary with a 60% antifreeze and 40% water mixture.

WARNING

Always remove pressure cap from a hot engine very carefully with a rag over the cap. Unscrew the cap to the first stop only, until all pressure is released or serious burns from hot coolant may result.

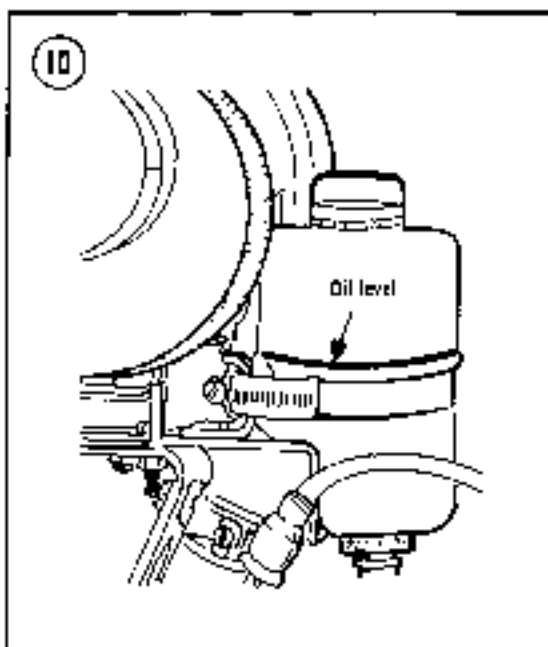
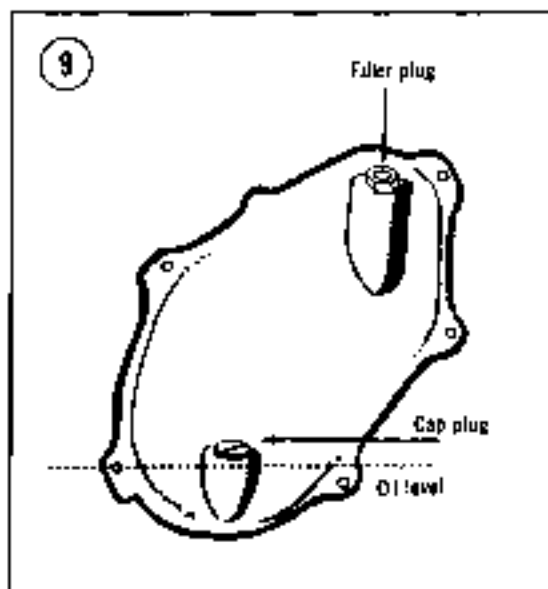

TRACK TENSION ADJUSTMENT

Proper track tension is very important to obtain maximum life and service from the track. Check for track "ratcheting" and proper tension at intervals specified in Table 1 earlier in this chapter.

Track "ratcheting" occurs if track is too loose and drive lugs on the track slip over the cogs on the drive wheel.

Table 2 TRACK TENSION ADJUSTMENT SPECIFICATIONS

Suspension	Adjustment
Bogie wheel suspension	
1970-1971 models (measured from bottom edge of center bogie wheel to inside edge of track)	2 ¹ / ₂ -3 in. (6.4-7.6 cm)
All other models (measured from top inside edge of track to bottom of foot board)	
Elar	1 ¹ / ₂ -1 ¹ / ₂ in. (3.2-3.8 cm)
Olympique	2 ¹ / ₈ -2 ¹ / ₈ in. (5.4-6.0 cm)
Slide suspension	
All models (1970-1973) (measure from foot board to inside of track)	5 ¹ / ₂ -6 in. (14.6-15.2 cm)
1974 and later (measure between bottom of slider shoe and inside of track)	
Ground leveler suspension	1 ¹ / ₂ -1 ³ / ₈ in. (3.1-3.6 cm)
High performance suspension	1 ¹ / ₈ in. (1.6 cm)
Torque reaction suspension	
All Olympique; all 1978-1979 models	1 ¹ / ₂ in. (3.8 cm)
All other models	1 ¹ / ₂ in. (3.9 cm)

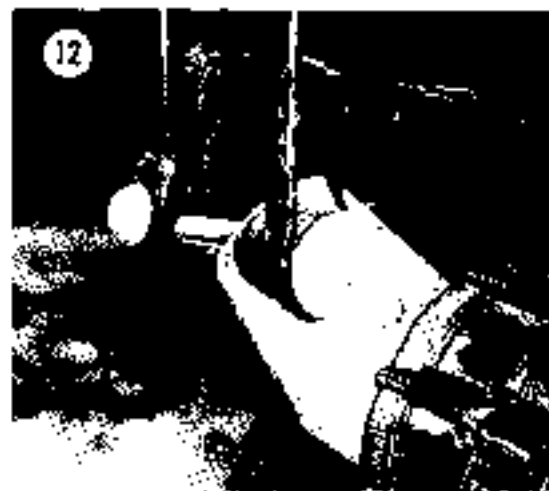

(Figure 11). Do not attempt to correct track tension by changing position of link plate springs.

Bogie Suspension

1. Raise rear of snowmobile; block securely.
2. Measure track tension as specified in **Table 2**.
3. If track tension is incorrect perform the following:

NOTE: On models with 3-position link plate spring anchors, ensure that link plate springs are in middle position

- a. Loosen link plate spring locknuts on inner side of link plate springs (**Figure 12**).
 - b. Turn adjuster bolts clockwise to increase tension and counterclockwise to release tension (**Figure 13**).
 - c. Adjust track tension to specified value and tighten locknuts.
4. Check track alignment as follows:

WARNING

Before rotating track, ensure that track is clear. Any tools or other objects on track could be thrown back causing serious injury.

- Start engine and rotate track slowly.
- Check that track is well-centered and distance between edge of track and link plate is the same on each side (Figure 14).
- If track is not aligned, loosen link plate spring locknut and turn adjuster (on side where track is closer to link plate) clockwise until track is realigned.
- Tighten locknut and recheck track tension. Readjust if necessary.

NOTE: Track tension and alignment are interrelated. Do not adjust one without checking the adjustment of the other.

- Remove block from rear of snowmobile.

Slide Suspension

- Raise rear of snowmobile; block securely.
- Measure track tension as in Table 2.
- If track tension is incorrect perform the following:

- Loosen locknuts on adjuster bolts located inside of rear idler wheels (Figure 15).
- Turn adjuster bolts clockwise to increase tension and counterclockwise to release tension.
- Adjust track tension to specified value and tighten locknuts.

- Check track alignment as follows:

WARNING

Before rotating track ensure that track is clear. Any tools or other objects on track could be thrown back causing serious injury.

NOTE: Track tension and alignment are interrelated. Do not adjust one without checking the adjustment of the other.

- Start engine and rotate track slowly.
- Check that track is well-centered and distance between edge of track and frame is the same on each side.

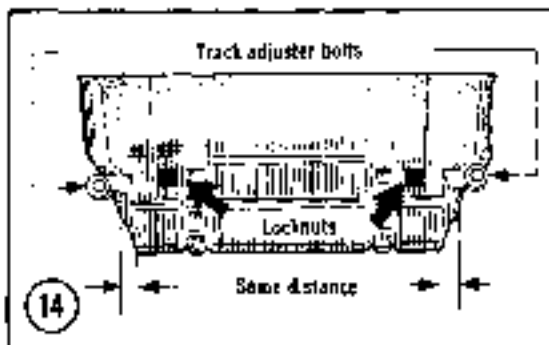
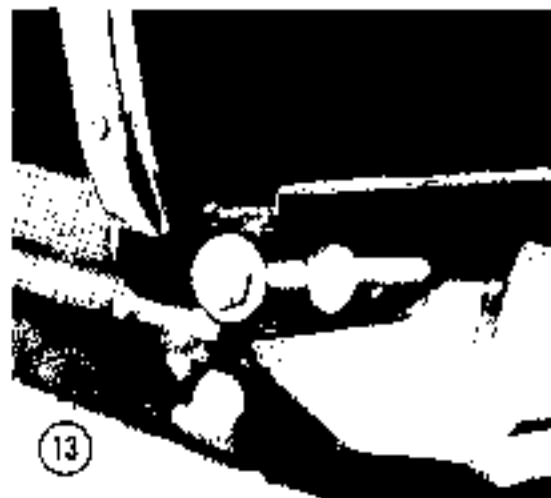

- If track is not aligned, loosen locknuts securing adjuster bolts and tighten adjuster on side where track is closer to frame.
- Tighten locknuts and recheck track tension. Readjust if necessary.

- Remove block from rear of snowmobile.

**SLIDE SUSPENSION
RIDE ADJUSTMENT**

See Table 3 for model application.

**Ground Leveler
and High Performance Suspension**

- Raise rear of snowmobile and block up securely.
- Tighten nuts on front spring adjuster bolts until outside of nut is $\frac{3}{8}$ - $\frac{1}{2}$ in. (15.9-22.2mm) from end of bolt (Figure 16). Ensure that both nuts are adjusted equally.

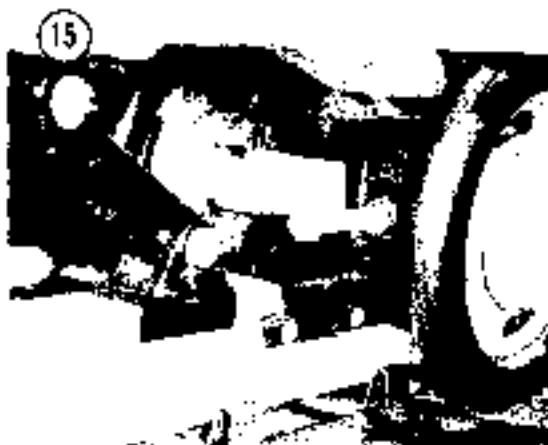

Table 3 SLIDE SUSPENSION MODEL

Model	Suspension
Olympique 1970-1974 TNT F/C 1970-1973 Elan 294 SS 1974 Elan 300 SS 1975	Ground leveller
TNT F/A 1973-1974	High performance
All other models	Torque reaction

3. Tighten nuts on rear spring adjuster bolts until outside of nut is $\frac{7}{8}$ - $1\frac{1}{4}$ in. (22.2-28.6mm) from end of bolt (Figure 16). Ensure that both nuts are adjusted equally.

4. Adjuster nuts can be tightened further if firmer ride is desired. Best all-around traction and ride are obtained if 5 in. (13 cm) clearance exists between rear of foot rest and the ground when driver is seated on snowmobile.

Torque Reaction Suspension

1. Measure distance between rear of foot rest and ground with driver in snowmobile. Distance should be $4\frac{1}{2}$ - $5\frac{1}{2}$ in. (11-14 cm).

NOTE: Front cam adjusters are for various snow conditions. Cams should be in lower position for deep snow and higher position for dry snow. Rear cams are adjusted for differing driver weights.

A spark plug wrench makes an ideal adjusting tool.

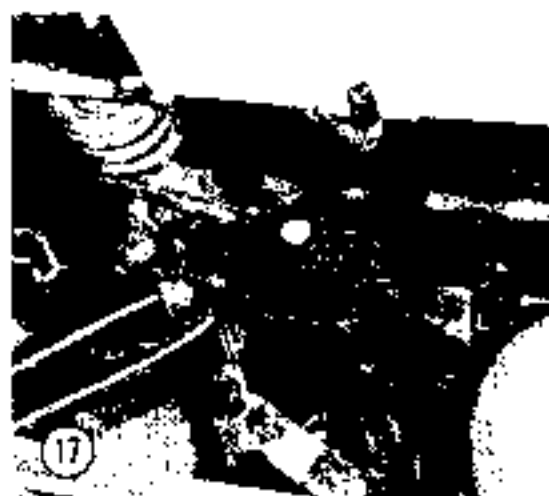
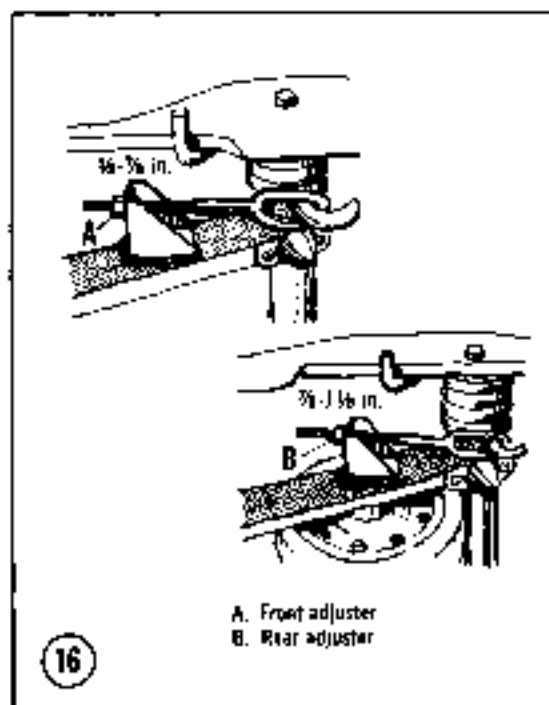

2. Adjust front cams as desired for snow conditions (Figure 17). Adjust rear cams for specified distance between foot rest and ground (Figure 18).

CAUTION

Always turn left side adjustment cams clockwise and right side cams counterclockwise. Ensure that left front cam is set at the same elevation as right front and left rear is set the same as right rear.

HARDWARE AND COMPONENT TIGHTNESS CHECK

Hardware and components on all machines should be checked at least once a year. An ideal time is when the machine is placed in or removed from storage. Check the tightness of all bolts, nuts, and fasteners. Check for any damaged or worn parts, and areas that require special attention or repair. Refer to **Figure 19** for forward engine models and **Figure 20** for mid-engine models.

ENGINE TUNE-UP

In order to maintain your snowmobile in proper running condition, the engine must receive periodic tune-ups. Since different systems in an engine interact to affect overall performance, the tune-up procedures should be performed in a sequence with time spent to double check all adjustments.

Normal tune-up procedures should begin with ignition adjustment, then be followed by carburetor adjustment. Since all adjustments interact, recheck items like idle adjustments after completing the entire tune-up procedure.

Always check the condition of spark plug wires, ignition wires, and fuel lines for splinting, loose connections, hardness, and other signs of deterioration. Check that all manifold nuts and carburetor nuts are tight and no crankcase leaks are present. A small air leak can make a good

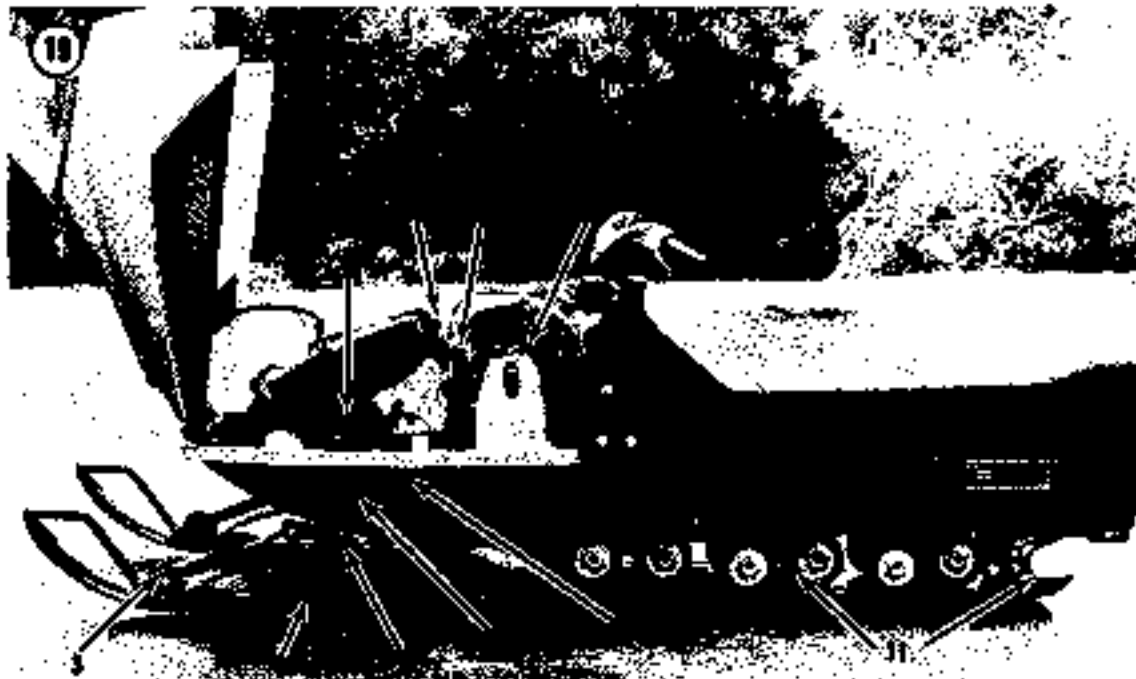

- | | |
|----------------------------------|--------------------------------------|
| 1. Ski runner nuts | 7. Engine mounting bolts |
| 2. Ski bolts | 8. Carburetor attaching nuts on base |
| 3. Shock absorber attaching bolt | 9. Air silencer and fuel lines |
| 4. Steering arm cap screws | 10. Drive pulley support |
| 5. Tie rod end locknuts | 11. Suspension components |
| 6. Drive pulley retaining ball | |

tune-up impossible as well as affect performance. A small air leak can also cause serious damage by allowing the engine to run on a "too-lean" fuel mixture.

Tune-up Hints

The following list of general hints will help make a tune-up easier and more successful:

1. Always use good tools and tune-up equipment. The money saved from one or two home tune-ups will more than pay for good tools; from that point you're money ahead. Refer to Chapter One for suitable types of tune-up/test equipment.
2. The purchase of a small set of ignition wrenches and one or two "screwholding" or magnetic screwdrivers will ease the work in replacing breaker points and help eliminate losing small screws.
3. Always purchase quality ignition components.
4. When using a feeler gauge to set breaker points, ensure that the blade is wiped clean before inserting between the points.
5. Ensure that points are fully open when setting gap with a feeler gauge.
6. Be sure that feeler gauge is not tilted or twisted when it is inserted between the contacts. Closely observe the points and withdraw the feeler gauge slowly and carefully. A slight resistance should be felt, however, the movable contact point must *not* "spring back" even slightly when the feeler gauge blade is removed.
7. If breaker points are only slightly pitted, they can be "dressed down" lightly with a small ignition point file. *Do not* use sandpaper as it leaves a residue on the points.
8. After points have been installed, always ensure that they are properly aligned, or premature pitting and burning will result (Figure 21). Bend only the *fixed* half of the points; not the movable arm.

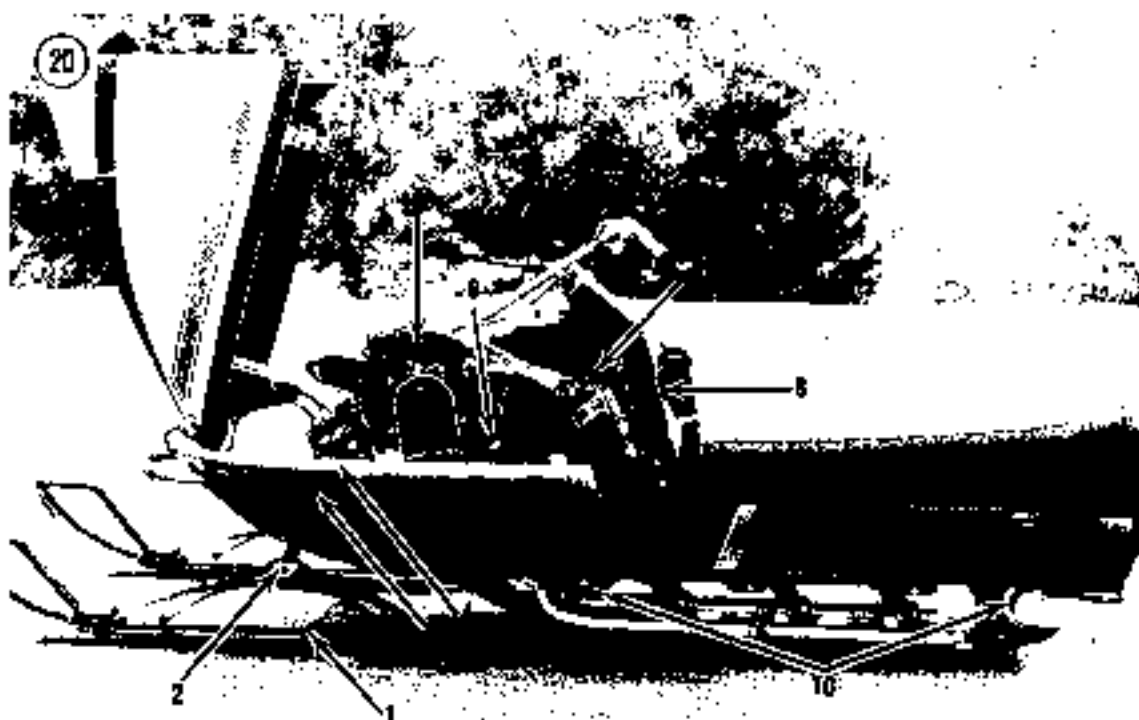

- | | |
|--------------------------------|--------------------------------------|
| 1. Ski runner nuts | 6. Engine mounting belts |
| 2. Ski bolts | 7. Carburetor attaching nuts |
| 3. Steering arm cap screws | 8. Air filter and fuel lines |
| 4. Tie rod end locknuts | 9. Drive pulley support on hinge rod |
| 5. Drive pulley retaining bolt | 10. Suspension components |

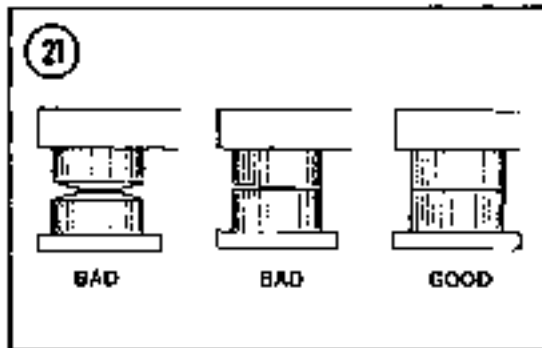

9. When point gap has been set, spring points open and insert a piece of clean paper or cardboard between the contacts. Wipe the contact a few times to remove any trace of oil or grease. A small amount of oil or grease on the contact surfaces will cause the points to prematurely burn or arc.

10. When connecting a timing light or timing tester, always follow the manufacturer's instructions.

Spark Plugs

Among the first steps to be done during any tune-up is to remove and examine the spark plug. Condition of a used spark plug can tell much about engine condition and carburetion to a trained observer.

To remove the spark plug, first clean the area around its base to prevent dirt or other foreign material from entering the cylinder. Next, unscrew the spark plug, using a $\frac{1}{8}$ in. deep socket. If difficulty is encountered removing a spark plug, apply penetrating oil to its base and allow some 20 minutes for the oil to work in. It may also be helpful to rap the cylinder head lightly with a rubber or plastic mallet; this procedure sets up vibrations which helps the penetrating oil to work in.

The proper heat range for spark plugs is determined by the requirement that the plugs operate hot enough to burn off unwanted deposits, but not so hot that they burn themselves or cause preignition. A spark plug of the correct heat range will show a light tan color on the portion of the insulator within the cylinder after the plug has been in service. Figure 22 illustrates the different construction of the various heat ranges.

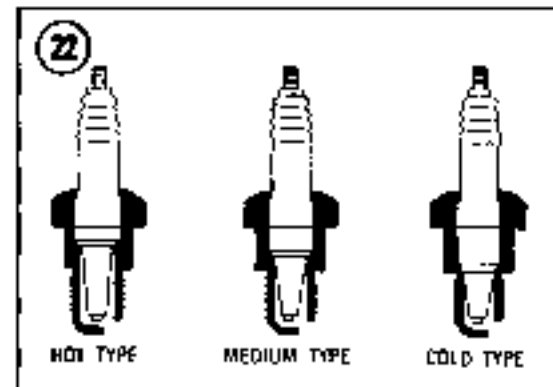

Table 4 CAUSES OF FOULED PLUGS

• Improper fuel/oil mixture	• Weak ignition
• Wrong type of oil	• Excessive idling
• Idle speed too low	• Wrong spark plugs (too cold)
• Clogged air filter	

Figure 23 illustrates various conditions which might be encountered upon plug removal.

1. *Normal condition* — If plugs have a light tan or gray colored deposit and no abnormal gap wear or erosion, good engine, carburetion, and ignition condition are indicated. The plug in use is of the proper heat range, and may be serviced and returned to use.

2. *Oil fouled* — This plug exhibits a black insulator tip, damp oily film over the firing end, and a carbon layer over the entire nose. Electrodes will not be worn. Common causes for this condition are listed in Table 4.

Oil fouled spark plugs may be cleaned in a pinch, but it is better to replace them. It is important to correct the cause of fouling before the engine is returned to service.

3. *Overheated* — Overheated spark plugs exhibit burned electrodes. The insulator tip will be light gray or even chalk white. The most common cause of this condition is using a spark plug of the wrong heat range (too hot). If it is known that the correct plug is used, other causes are lean fuel mixture, engine overloading or lugging, loose carburetor mounting, or timing advanced too far. Always correct the fault before putting the snowmobile back into service. Such plugs cannot be salvaged; replace with new ones.

SPARK PLUG CONDITIONS

23



NORMAL USE



OIL FOULED



CARBON FOULED



OVERHEATED



GAP BRIDGED



SUSTAINED PREIGNITION



WORN OUT

Photos courtesy of Champion Spark Plug Company.

4. *Preignition* — If electrodes are melted, preignition is almost certainly the cause. Check for carburetor mounting or intake manifold leaks, also overadvanced ignition timing. It is also possible that a plug of the wrong heat range (too hot) is being used. Find the cause of preignition before placing the engine back into service.

5. *Carbon fouled* — Soft, dry sooty deposits are evidence of incomplete combustion and can usually be attributed to rich carburetion. This condition is also sometimes caused by weak ignition, retarded timing, or low compression. Such a plug may usually be cleaned and returned to service, but the condition which causes fouling should be corrected.

6. *Gap bridging* — Plugs with this condition exhibit gaps shorted out by combustion chamber deposits used between electrodes. On 2-stroke engines either of the following may be the cause.

- a. Improper fuel/oil mixture
- b. Clogged exhaust

Be sure to locate and correct the cause of this spark plug condition. Such plugs must be replaced with new ones.

7. *Worn out* — Corrosive gases formed by combustion and high voltage sparks have eroded the electrodes. Spark plugs in this condition require more voltage to fire under hard acceleration; often more than the ignition system can supply. Replace them with new spark plugs of the same heat range.

The spark plugs recommended by the factory are usually the most suitable for your machine. If riding conditions are mild, it may be advisable to go to spark plugs one step hotter than normal. Unusually severe riding conditions may require slightly colder plugs. See **Table 5**.

CAUTION

Ensure that spark plugs used have the correct thread reach. A thread reach too short will cause the exposed threads in the cylinder head to permeate carbon, resulting in stripped cylinder head threads when the proper plug is installed. A thread reach too long will cause the exposed spark plug threads to accumulate carbon resulting in stripped cylinder head threads when the plug is removed.

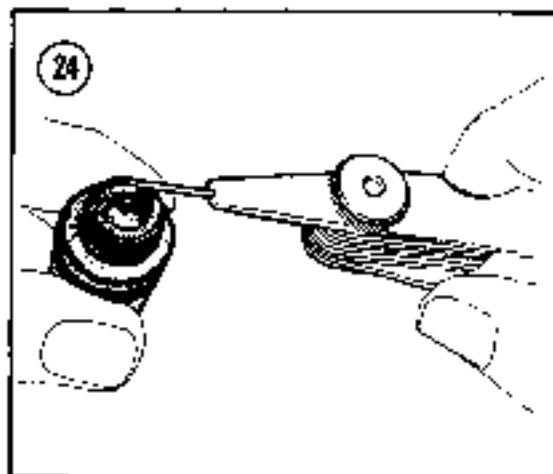

It may take some experimentation to arrive at the proper plug heat range for your type of riding. As a general rule, use as cold a spark plug as possible without fouling. This will give the best performance.

Remove and clean spark plugs at least once a season. After cleaning, inspect them for worn or eroded electrodes. Replace them if in doubt about their condition. If the plugs are serviceable, file the center electrodes square, then adjust the gaps by bending the outer electrodes only. Measure the gap with a round wire spark plug gauge only; a flat gauge will yield an incorrect reading. **Figure 24** illustrates proper spark plug gap measurement. Gap should be 0.020 in. (0.51mm).

Be sure to clean the seating area on the cylinder head and use a new gasket whenever you replace a spark plug. Install the plug finger-tight, then tighten it an additional $\frac{1}{2}$ turn. If using a torque wrench, torque spark plugs to 20 ft.-lb. (2.8 mkg), for 14mm plugs and 30 ft.-lb. (4.1 mkg) for 18mm plugs.

Single Cylinder Engine Breaker Point and Timing Adjustment

Refer to list of general tune-up hints as outlined under *Engine Tune-Up*.

1. Remove spark plug.
2. Remove recoil starter and starting pulley from magneto ring (**Figure 25**).
3. Rotate crankshaft until breaker points are fully open (viewed through magneto ring). See **Figure 26**.

Table 5 SPARK PLUG APPLICATION

Model	Champion		Bosch	
	Standard	Gold Palladium	Standard	Silver Sport
Elan 250, Olympique 300 (299 engine); Olympique 335, 440 (1973); Olympique 300 (1976)	K-9	K-8G	M175T1	-
TNT FA, LNT RV, TNT 440 (1973) (14mm heads); and RV 340	RM 2	N-2C	W280M22	W280S1S
Elan 250 Twin and Deluxe to 1977 Olympique 300T, 340, 399, TNT 399	L-R1	L-6G	W240T1	W261S1S
Olympique 300 Twin (1978 and later); Olympique 340, 340E (1978 and later); Citation 300 (1978 and later) Everest 340, 340E (1978 and later)	L-78	L-4G	W280M21	-
TNT 340 (1978) Blizzard 6500, 7500, 9500 Blizzard 5500	L-78	L-4G	W260M21 W341S2S W275T2	- - -
Everest 440, 440E; TNT 440 L/C	K-7	K-5G	M260T1	W260S1S
Everest 441 L/C	N-3	N-3G	W260M72 or W280M72 with 2 gaskets	-
Elan 250SS, 300SS, TNT 294, 300, 340 Everest 340 (to 1977) Olympique 340 (to 1977) TNT 292 single TNT 440; Everest 440 (to 1977)	L-78	L-4G	M260T1	-

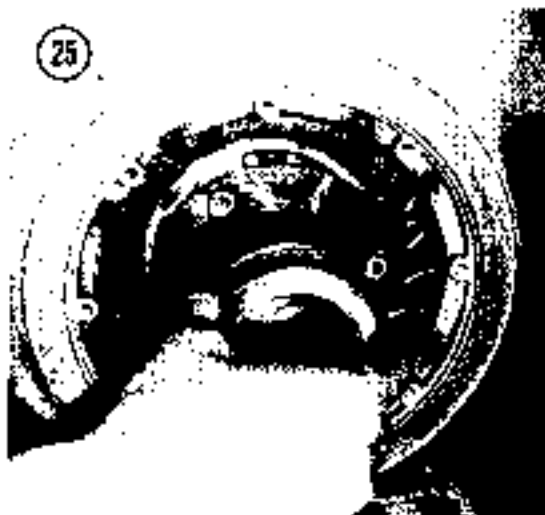

4. Carefully examine points and dress with file or replace as necessary.

5. Loosen screw securing breaker points. Using a feeler gauge set breaker point gap to 0.014-0.018 in. (0.35-0.45mm). Tighten screw securing breaker points. Recheck gap as gap can change when screw is tightened, readjust if necessary.

6. Disconnect electrical junction block at engine and connect a flashlight-type or tone-type timing tester. Connect one lead to black wire leading from engine and the other lead to a good ground such as fan cowl.

NOTE: More precise timing can be achieved by using a dial indicator-type gauge as described in Chapter One. If dial indicator gauge is used proceed to Step 9. If gauge is not used perform next step.

7. Turn on flashlight or tone tester and rotate magneto until timing marks align (Figure 27).

8. Loosen 3 screws retaining armature plate (Figure 28, magneto/fan assembly removed for clarity) and rotate plate until timing light fluctuates or tone signal changes. This indicates points are just starting to open. Tighten armature plate retaining screws. Recheck point gap and timing and readjust if necessary. Proceed to Step 14.

NOTE: In order to get breaker points to just begin to open when timing marks are aligned, it may be necessary to slightly change breaker point gap, however never vary gap beyond specified tolerance of 0.014-0.018 in. (0.35-0.45mm).

9. Install dial indicator gauge in spark plug hole. Rotate engine until piston is at TDC (top dead center) and "zero" gauge according to manufacturer's instructions (Figure 29).

10. Rotate engine until dial indicator gauge indicates piston is BTDC (before top dead center) the amount specified in Table 6.

NOTE: On engines with vertical spark plug hole use direct timing specification, Table 6. Engines with spark plug hole on an angle use indirect timing specifications.

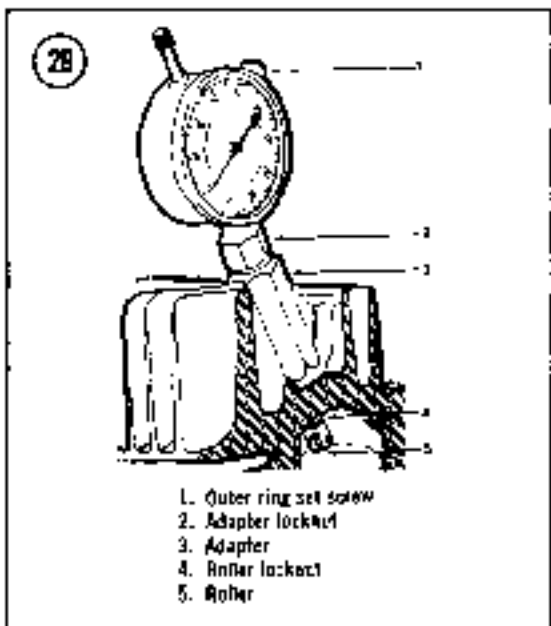

Table 6 IGNITION TIMING SPECIFICATIONS

Engine	Direct Timing BTDC ¹	Indirect Timing BTDC ¹
245 (1976) ^a	0.035-0.055 in. (0.90-1.40mm)	N/A
245 (1975) ^a	0.037-0.057 in. (0.95-1.45mm)	N/A
247	0.147-0.167 in. (3.73-4.23mm)	N/A ²
248, 249	0.077-0.097 in. (1.97-2.47mm)	0.100-0.100 in. (2.04-2.54mm)
250	0.150-0.170 in. (3.81-4.31mm)	0.150-0.160 in. (3.81-4.06mm)
292 (1970-1971)	0.140-0.160 in. (3.55-4.06mm)	0.195-0.221 in. (4.95-5.61mm)
292, 302 (1972)	0.147-0.167 in. (3.73-4.23mm)	0.195-0.215 in. (4.95-5.46mm)
294	0.084-0.104 in. (2.14-2.64mm)	0.087-0.110 in. (2.19-2.79mm)
300	0.150-0.170 in. (3.81-4.31mm)	0.205-0.241 in. (5.20-6.12mm)
302	0.147-0.167 in. (3.73-4.23mm)	0.212-0.244 in. (5.38-6.20mm)
305	0.111-0.131 in. (2.82-3.32mm)	0.135-0.159 in. (3.43-4.03mm)
304, 343 ³ (1978)	0.073-0.093 in. (1.86-2.36mm)	0.087-0.107 in. (2.21-2.71mm)
335	0.160-0.180 in. (4.06-4.57mm)	0.220-0.250 in. (5.59-6.35mm)
337	0.157-0.177 in. (3.99-4.49mm)	0.229-0.249 in. (5.81-6.32mm)
338	0.111-0.131 in. (2.82-3.32mm)	0.132-0.154 in. (3.35-3.89mm)
340 (1970)	0.160-0.180 in. (4.06-4.57mm)	0.198-0.228 in. (5.02-5.79mm)
340 (1971)	0.160-0.180 in. (4.06-4.57mm)	0.193-0.220 in. (4.90-5.59mm)
343 (1972)	0.137-0.157 in. (3.48-3.98mm)	0.159-0.179 in. (4.03-4.53mm)
343 (1973)	0.111-0.131 in. (2.82-3.32mm)	0.131-0.154 in. (3.33-3.91mm)
343	0.111-0.131 in. (2.82-3.32mm)	0.135-0.159 in. (3.43-4.03mm)
345 ^a	0.035-0.055 in. (0.90-1.40mm)	N/A
345 (1978) ^a	0.034-0.054 in. (0.87-1.37mm)	N/A
346 (1973) ^a	0.109-0.129 in. (2.77-3.28mm)	N/A
396 (1973) ^a	0.060-0.080 in. (1.52-2.03mm)	N/A
346, 396 (1974) ^a	0.071-0.091 in. (1.82-2.32mm)	N/A
354 ^a , 454 ^a	0.045-0.065 in. (1.14-1.64mm)	N/A
399, 440 (1970-1971)	0.160-0.180 in. (4.06-4.57mm)	0.148-0.171 in. (3.76-4.34mm)
401, 434, 435 (1972)	0.137-0.157 in. (3.48-3.98mm)	0.146-0.166 in. (3.71-4.22mm)
411	0.111-0.131 in. (2.82-3.32mm)	0.135-0.159 in. (3.43-4.03mm)
434, 440 ^d	0.111-0.131 in. (2.82-3.32mm)	0.118-0.144 in. (2.99-3.66mm)
435	0.111-0.131 in. (2.82-3.32mm)	0.119-0.141 in. (3.02-3.58mm)
436 ^a	0.071-0.091 in. (1.82-2.32mm)	N/A
440 (1975) ^a	0.110-0.091 in. (1.82-2.32mm)	0.077-0.097 in. (1.96-2.46mm)
440 (1978-1979)	0.111-0.131 in. (2.82-3.32mm)	0.120-0.141 in. (3.05-3.56mm)
444	0.082-0.102 in. (2.10-2.60mm)	N/A
503	0.068-0.088 in. (1.72-2.22mm)	N/A

^a Engines equipped with CDI

1. Use direct timing for engines with vertical spark plug holes and indirect timing for engines with spark plug on an angle.
2. On 1972 models, indirect specification is the same as direct.
3. On 343 engines serial number 3,019,645 to 3,020,644 direct timing is 0.147-0.167 in. (3.73-4.23mm).
4. Except 1975-440 with CDI.

11. Turn on flashlight or tone tester and loosen 3 screws securing armature plate (Figure 28).

12. Hold advance mechanism weight in full advance position (toward magneto ring). See Figure 30.

13. Slowly rotate armature plate until timing light fluctuates or tone signal changes. This indicates points are just starting to open. Tighten armature plate retaining screws. Recheck point gap and timing, readjust if necessary.

14. Remove timing tester. Remove dial indicator gauge if used. Connect electrical junction block.

15. Install starting pulley and recoil starter. Install spark plug.

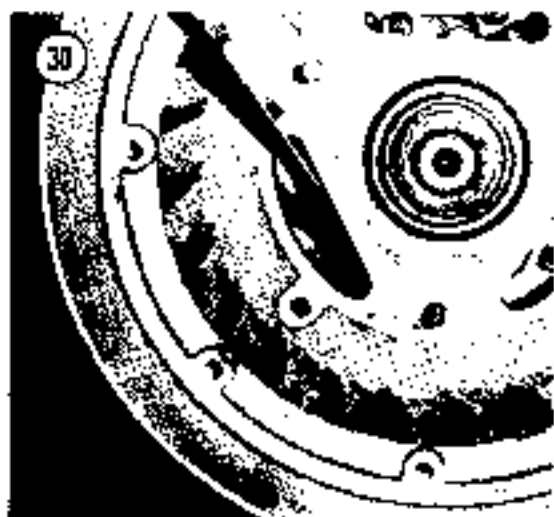

Two Cylinder Engine Breaker Point and Timing Adjustment

Refer to list of general tune-up hints as outlined under *Engine Tune-Up*.

1. Remove spark plugs.
2. Remove recoil starter and fan cover.
3. Remove starting pulley and fan drive belt (Figure 31).
4. Rotate crankshaft until breaker points are fully open (viewed through magneto ring opening). See Figure 32.

NOTE: Upper breaker points apply to magneto side piston; lower points apply to PTO (power take off) side.

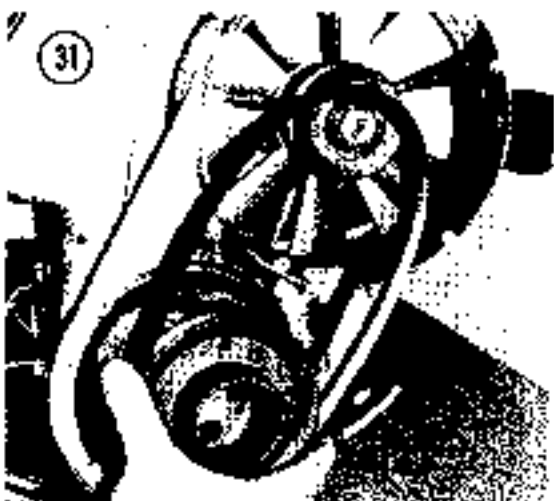

5. Carefully examine points and dress with file or replace as necessary.

6. Loosen screw securing breaker points. Using a feeler gauge set breaker point gap to 0.014-0.018 in. (0.35-0.45mm). See Figure 32. Tighten screw securing breaker points. Recheck gap as gap can change when screw is tightened; readjust if necessary. Repeat for other set of breaker points.

7. Disconnect electrical junction block at engine and connect a flashlight-type or tone-type timing tester. Connect one lead to blue wire (magneto side points) leading from engine. Connect other lead to a good ground such as fan cowl.

NOTE: More precise timing can be achieved by using a dial indicator-type



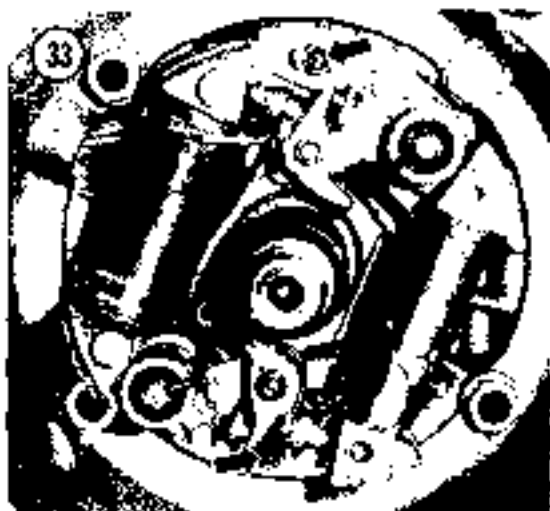

gauge as described in Chapter One. If dial indicator gauge is used proceed to Step 13. If gauge is not used perform next step.

8. Loosen 2 screws or nuts securing armature plate (Figure 33, magneto removed for clarity).

9. Turn on flashlight or tone tester and rotate crankshaft until magneto side piston approaches TDC (top dead center) and timing marks align (Figure 34).

10. Rotate armature plate until timing light fluctuates or tone signal changes. This indicates points are just starting to open. Tighten armature plate retaining screws. Rotate crankshaft counterclockwise approximately $\frac{1}{4}$ turn and then slowly rotate crankshaft back clockwise until timing marks are aligned. Check that points just start to open. Tightening armature plate retaining screws can cause timing to shift slightly. Readjust timing if necessary.

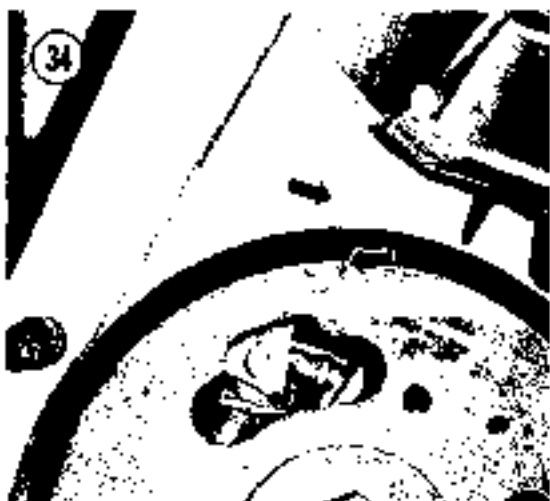

NOTE: It is necessary to hold centrifugal advance mechanism in the fully advanced position (toward magneto end) while rotating armature plate to set timing (Figure 35) on the following engines:

- 305 engines*
- 343 engines, serial No. 2,670,920 and subsequent*
- 346 engines*
- 402 engines*
- 440 engines, serial No. 2,748,146 and subsequent*
- 444 engines*

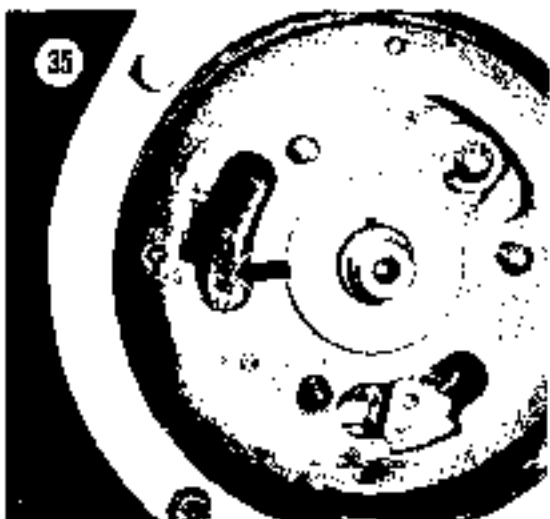

11. Disconnect timing tester lead from blue wire and connect to blue/red (PRO side points) leading from engine.

12. Turn on timing tester and rotate crankshaft until timing marks align. Timing light should fluctuate or tone signal should change. If timing is incorrect adjust lower set of points as follows:

- a. If timing is too early, decrease point gap toward lower limit, 0.014 in. (0.35mm), until correct timing is achieved
- b. If timing is too late, increase point gap toward upper limit, 0.018 in. (0.45mm), until correct timing is achieved

- c. After tightening breaker point retaining screw, recheck timing and readjust if necessary. Proceed to Step 19.

13. Install dial indicator gauge in magneto side spark plug hole. Rotate crankshaft until piston is at top (top dead center) and "zero" gauge according to manufacturer's instructions (Figure 29).

14. Loosen 2 screws or nuts securing armature plate (Figure 33, magneto removed for clarity). Turn on timing tester and rotate crankshaft until piston is specified distance above (before top dead center), Table 6.

NOTE: On engines with vertical spark plug hole use direct timing specifications, Table 6. Engines with spark plug hole in an angle use indirect timing specifications.

15. Hold advance mechanism in fully advanced position (toward magneto ring) and slowly rotate armature plate until light fluctuates or tone signal changes (Figure 35). Tighten plate retaining screws and recheck timing. Readjust if necessary.

16. Disconnect timing tester lead from blue wire and connect to blue/red wire (PTO side points) leading from engine.

17. Remove dial indicator gauge from magneto side and install in PTO side spark plug hole and "zero" gauge when piston is at top.

18. Hold advance mechanism in fully advanced position and rotate crankshaft until piston is specified distance above, Table 6. Timing light should fluctuate or tone signal should change. If timing is incorrect, adjust lower set of points as follows.

NOTE: Do not loosen screws on armature ring or magneto side timing will be changed, requiring complete timing procedure to be repeated.

- a. If timing is too early, decrease point gap toward lower limit, 0.014 in. (0.35mm), until correct timing is achieved.
- b. If timing is too late, increase point gap toward upper limit, 0.018 in. (0.45mm), until correct timing is achieved.

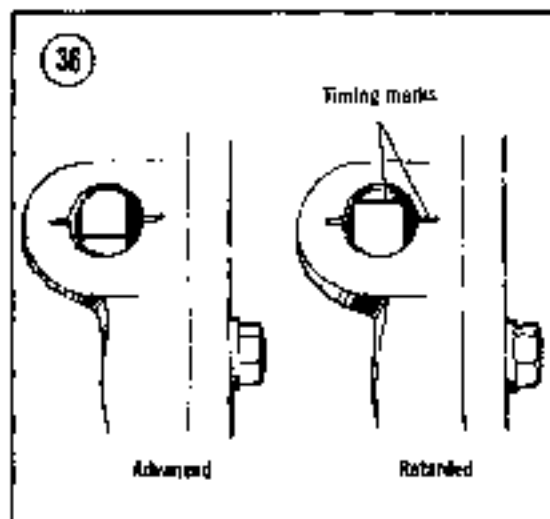

- c. After tightening breaker point retaining screw, recheck timing and readjust if necessary.

19. Remove timing tester. Remove dial indicator gauge if used. Connect electrical junction block.

20. Install starting pulley and fan belt.

21. Install recoil starter, fan cover, and spark plugs.

CDI Ignition Timing (Except J54 Engines)

1. Raise rear of snowmobile off ground and block up securely.

WARNING

Ignition timing requires engine be run at 5,000 rpm. Ensure that track area is clear, pulley guard is in place, and no one walks behind track or serious injuries may result.

2. Remove rubber plug from upper crankcase.
3. Connect an external powered timing light to magneto side spark plug wire.

NOTE: If DC powered timing light is used, connect light to an external battery.

4. Start engine and run up to 5,000 rpm. Timing marks on crankcase and magneto ring should align (Figure 36). If marks do not align perform the following:

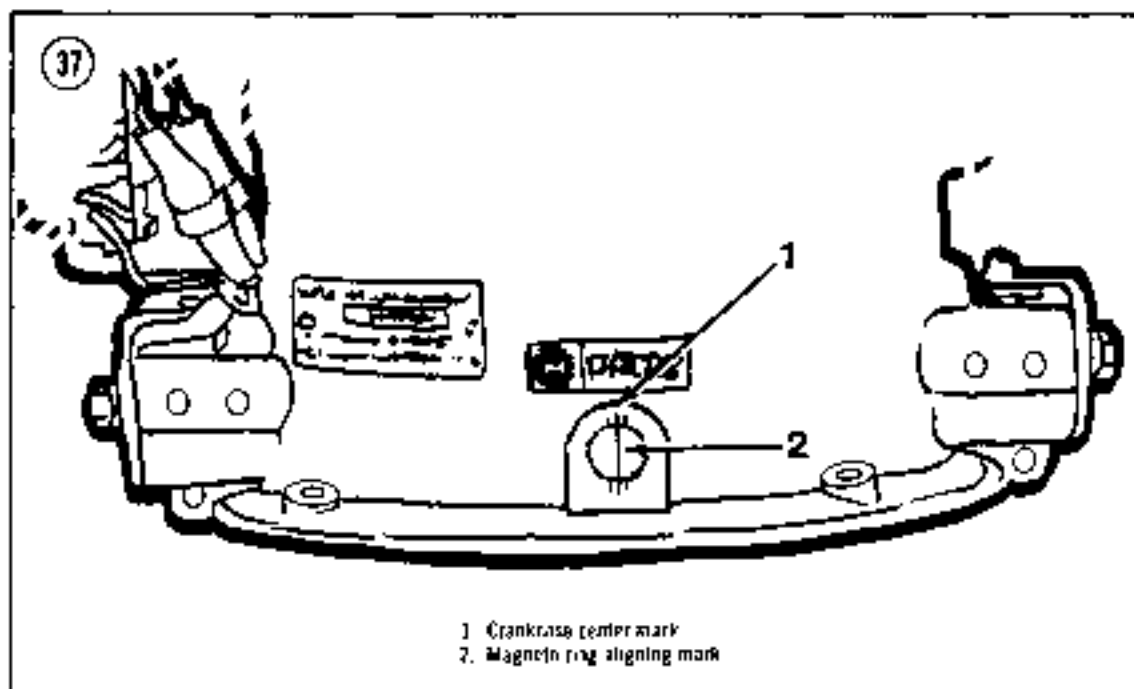
**CAUTION**

Do not run engine more than necessary or excessive starter/size wear may result.

- Remove recoil starter and starting pulley.
- Loosen Allen screws securing armature plate. Rotate plate clockwise to retard timing and counterclockwise to advance timing.
- Recheck timing and readjust if necessary.

5. With engine off, connect timing light to PTO (power take off) side spark plug wire.

6. Start engine and run up to 5,000 rpm. Timing should coincide with magneto side timing. If PTO timing is incorrect perform the following:

- Remove PTO spark plug and install a dial indicator timing gauge (described in Chapter One) in spark plug hole.
- Rotate engine until piston is at TDC (top dead center) and "zero" gauge according to manufacturer's instructions.
- Rotate crankshaft until piston is specified distance BTDC (before top dead center). See Table 6.
- Scribe marks on magneto rings for lower and upper limits of specified dimension. Repeat for magneto side piston.

e. Position armature plate so both cylinders fire within upper and lower limits of specified timing tolerance.

- Remove timing light and install rubber plug in crankcase.
- Install starting pulley and recoil starter if removed.
- Remove block from rear of snowmobile.

CBI Ignition Timing (354 Engines)

1. Raise rear of snowmobile off ground and block up securely.

WARNING

Ignition timing requires engine be run at 6,000 rpm. Ensure that track wear is clear, pulley cover is in place, and no one walks behind track or seats injuries may result.

- Remove rubber plug from upper crankcase.
- Install dial indicator gauge in spark plug hole. Rotate crankshaft until piston is at TDC (top dead center) and "zero" gauge according to manufacturer's instructions (Figure 29).
- With piston at TDC, rotate crankshaft until piston is positioned 0.055 in. (1.40mm) UTDC

Check that timing mark on the magneto ring aligns with the center mark on the crankcase as shown in Figure 37. If timing marks are incorrect, remark magneto ring. Repeat for the other piston.

5. Check air gap between the magneto ring and each trigger coil as shown in Figure 38. If air gap is incorrect, magneto ring will have to be removed and the armature plate repositioned (refer to *Flywheel and Magneto Removal* in Chapter Four). Air gap for each trigger coil should be 0.040-0.063 in. (1-1.6mm).

6. Connect an external powered timing light to magneto side spark plug wire. Use an external battery if using a m. powered timing light.

7. Start engine and run up to 6,000 rpm. Timing mark on magneto ring should align as shown in Figure 37. If marks do not align, perform the following:

- a. Loosen screw securing trigger coil bracket and adjust bracket up or down slightly until timing is correct (Figure 39). Repeat for the other cylinder.

NOTE: Magneto trigger coil is on carburetor side and P.T.O. trigger coil is on exhaust side.

- b. If insufficient travel of trigger coil bracket prevents correct timing, remove bracket and slightly move trigger coil on the bracket (Figure 40).

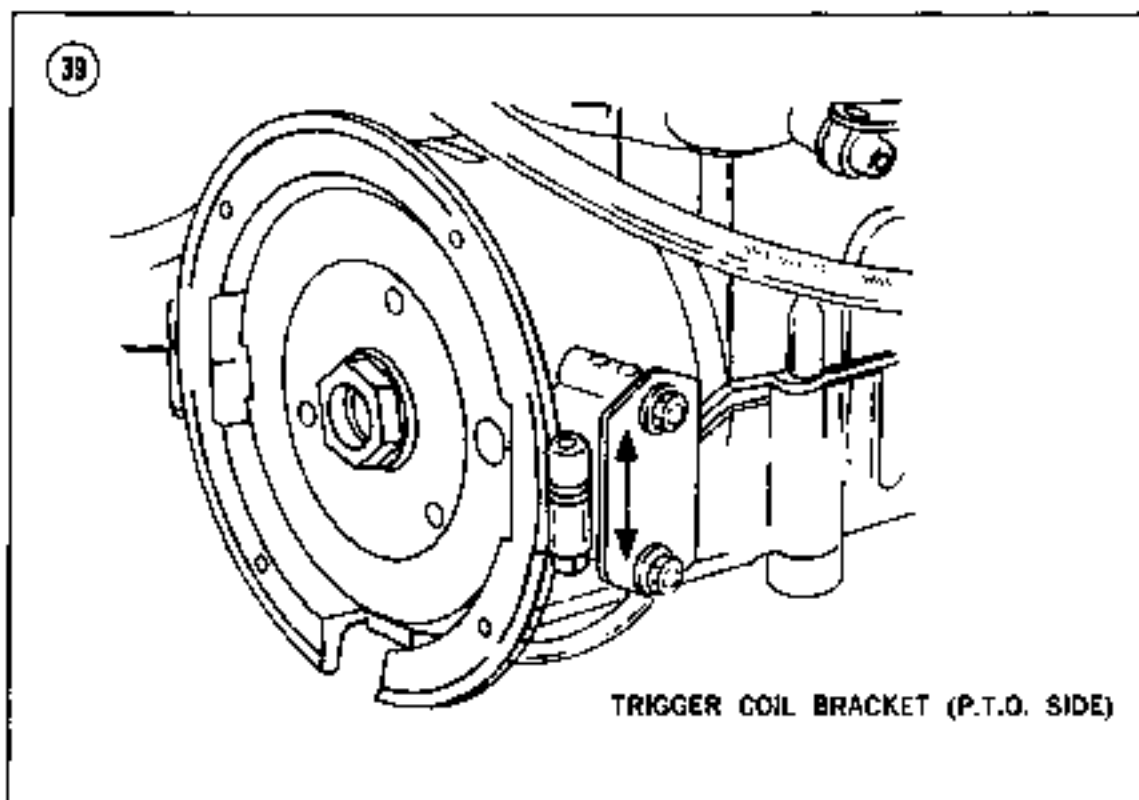
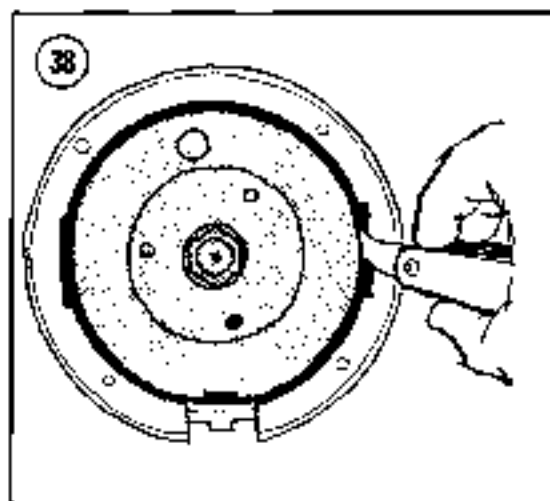

8. Remove timing light and install rubber plug in crankcase.
9. Remove block from rear of snowmobile.

Throttle Cable Adjustment (Tillotson Carburetors)

Adjust throttle cable (A, Figure 41) so throttle lever on carburetor is fully open when throttle control on the handlebar is in the wide-open throttle position.

CAUTION

Do not adjust cable too tightly (throttle on carburetor is wide-open before throttle control is fully open; handlebar) or cable may break due to excessive strain.

Tillotson Carburetor Adjustment

1. Gently close low-speed mixture needle (B, Figure 41) and high-speed mixture needle (A, Figure 42), if adjustable, until needle contacts seat. Back off mixture needles as specified in Table 7.

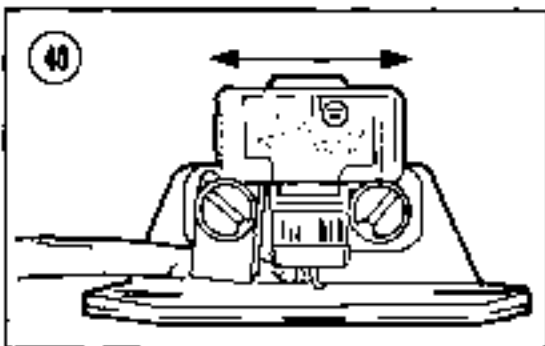

CAUTION

Close mixture needles carefully or damage to needle and/or seat may result.

2. Start and warm up engine. Turn idle speed adjustment screw (C, Figure 41) to achieve specified idle speed, Table 7.
3. Ensure that the high-speed needle (if adjustable) is set at specified preliminary setting, Table 7. Check and adjust mixture as follows:

CAUTION

If snowmobile is equipped with an air silencer, adjustments must be made with silencer installed or a "too lean" mixture and subsequent engine damage may result.

- a. Drive snowmobile approximately 1 mile at 6,000 rpm. Shut off engine with ignition switch or kill button; do not allow engine to idle.
- b. Remove spark plug(s) and examine insulator. A brownish tip indicates correct mixture. Black insulator indicates a "too rich" mixture and light grey insulator indicates a "too lean" mixture.
- c. If mixture is incorrect, adjust high-speed mixture needle. Turn needle clockwise to obtain a leaner mixture or counterclockwise to obtain a richer mixture. Adjust needle $\frac{1}{8}$ turn at a time and repeat high-speed run and spark plug examination after each run.



Table 7 TILLOTSON CARBURETOR SPECIFICATIONS

Model	Carburetor	Low Speed Adjustment (Turns)**	High Speed Adjustment (Turns)**	Idle Speed (rpm)
Elan				
250, 250 E (1971, 1972, early 1973)	HR-73A	3/4	1 1/4 ⓐ	*
250 (late 1973-1975)	HR-133A	3/4	Fixed	-
292 SS (1972)	HD-22B	3/4	1 1/4	*
250 T (1973)	HR-136A	3/4	Fixed	*
250 T, 250 Deluxe (1974)	HR-155A	1	Fixed	*
250 Deluxe (1975)	HR-165A	1	Fixed	*
250 (1976)	HR-173A	1	Fixed	*
250 SS (1973)	HR-143A (2)	3/4	Fixed	*
294 SS (1974)	HR-161A	3/4	Fixed	*
300 SS (1975)	HR-166A	3/4	Fixed	*
250 SS (1976)	HR-172A	1	Fixed	1,500-1,800
250 (1978-1979)	HR-173A	1	Fixed	1,800-2,000
250 Deluxe (1978-1979)	HR-172A	1	Fixed	1,800-2,200
Olympique				
300 (1971 early 1973)	HR-74A	3/4	1 1/4	*
300 (late 1973-1974)	HR-132A	3/4	1	*
300 (1975 and 1976 twin)	HR-169A	1	Fixed	1,500-1,800
300 (1976 single)	HR-174A	1	Fixed	1,200-1,500
335 (1970)	HR-176	3/4	1 1/4	*
335 (1971-1973)	HR-75A	3/4 ⓐ	1 1/4 ⓑ	*
340 (1973-1974)	HR-131A	3/4	Fixed	*
340 (1975-1976)	HR-170A, B	1	Fixed	1,500-1,800
399 (1970)	HR-168	3/4	1 1/4	*
399 (1971-1972)	HR-76A	3/4	1 1/4	*
400 (early 1973)	HR-76A	1	1 1/2	*
400 (late 1973-1974)	HR-134A	3/4	Fixed	*
440 (1973-1974)	HR-135A	3/4	Fixed	*
440 plus (1976)	HR-176A	1	Fixed	1,500-1,800
TNT				
292, 340 (1970, 1971, and 1972-292)	HD-22A, B	3/4	1 1/4	*
340 (1972)	HD-98A	1 1/2	1	*
294 (1973)	HR-137A (2)	3/4	Fixed	*
340 (1973)	HD-107A	3/4	Fixed	*
300 (1974)	HR-164A	1	1	*
340 (1974-1975)	HD-134A	1	1	*
340 (1976)	HD-148A	1	1	1,500-1,800
399 (1970)	HD-21A	3/4	1 1/4	*
440 (1971)	HD-73A	3/4	1 1/4	*

(continued)

Table 7 TILLOTSON CARBURETOR SPECIFICATIONS (continued)

Model	Carburetor	Low Speed Adjustment (Turns)**	High Speed Adjustment (Turns)**	Idle Speed (rpm)
TNT (con't.)				
440 (1972)	HD-83A	1 1/4	1 1/4	*
440 (1973)	HD-109A	1	1	*
440 and Everest (1974-1975)	HD-138A	1	1	*
440 and Everest (1976)	HD-147A	1	1	1,500-1,800
400 F/A (1972)	HD-104A (2)	3/4	1 1/4	*
440 F/A (1973-1974)	HR-149A (2)	1	1 1/4	*
400 F/A (1973-1974)	HD-123A (2)	1	3/4	*
340 F/A (1975)	HR-168A (2)	1	1 1/4	*
440 F/A (1974)	HRM-3A (2)	1	1 1/4	*
440 F/A (1975)	HRM-5A (2)	1	1	*

* Unless otherwise specified, idle speed is 1,800-2,200 rpm.
 ** Tolerance for all adjustments is $\pm 1/4$ turn.
 † Fixed jet on later 1973 models.
 ‡ On 1973 models turn low-speed needle $3/4$ and high-speed needle $1 1/4$.

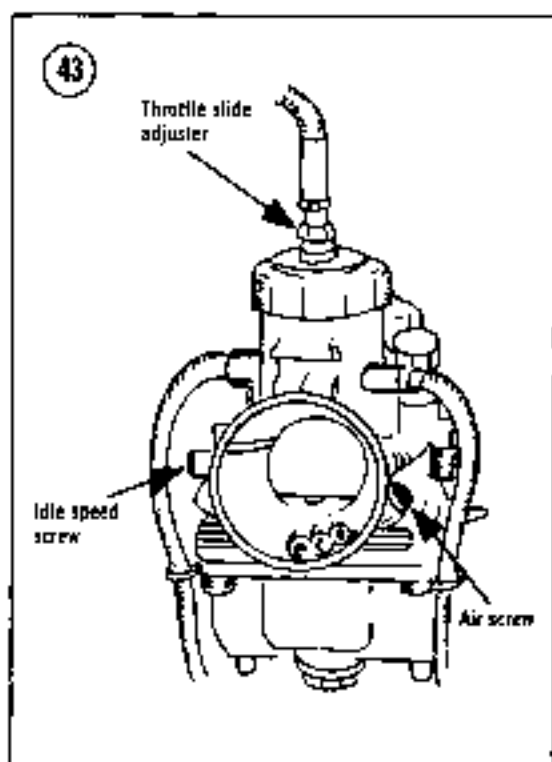
**CAUTION**

Continued operation with a "too lean" mixture can cause engine overheating and serious engine damage.

- d. If final adjustment is a considerable change from preliminary mixture needle setting, check for engine and/or carburetor air leaks, defective crankcase seals, or incorrect spark plug heat range.

Mikuni Carburetor Adjustment and Synchronization

This procedure includes throttle cable adjustments and idle speed adjustments for all models equipped with Mikuni carburetors.

On models equipped with 2 carburetors, more precise synchronization can be achieved with an air flow meter as described in Chapter One. If such a device is available, perform the following procedure as a preliminary adjustment and proceed to *Mikuni Carburetor Air Flow Meter Synchronization* for the final fine tuning.

Refer to Figure 43 for this procedure.

Table 8 MIKUNI CARBURETOR SPECIFICATIONS

Model	Carburetor	E-ring Position (From Top)	Air Screw Turns ($\pm 1/4$ Turn)
TNT R/V 245 (1975)	VM 34-72	2	1
TNT 340-340E kit (1976)	VM 34-109	3	1
TNT 440-440E kit (1976)	VM 34-105	2	1
Olympique 340-340E kit (1976)	VM 34-104	3	1
Olympique 300-300E kit (1976)	VM 34-103	3	1
TNT R/V 250 (1976)	VM 34-93	2	1
TNT R/V 340 (1976)	VM 34-94	2	1
Olympique 440 plus kit (1976)	VM 32-117	3	1 1/2
Olympique 300 (two) (1977-1978)	VM 30-90	3	1 1/2
Olympique 340-340E (1977-1979)	VM 30-91	3	1 1/2
Everest 340-340E kit (1977-1979)	VM 30-98	3	1 1/2
Olympique 440 (1977)	VM 32-113	4	1 1/2
TNT 340 F/A (1977-1978)	VM 34-118	3	1
TNT 440 F/A (1977)	VM 36-53	2	1
TNT 440 (1977)	VM 34-110	3	1 1/2
R/V 340 (1977-1978)	VM 34-135	4	1
Everest 440-440E (1977)	VM 34-110	3	1 1/2
Everest 440 L/C (1977)	VM 34-150	4	1
Citation 300 (1978)	VM 30-94	3	1 1/2
Citation 300 (1979)	VM 30-104	3	1 1/2
Everest 440, 440E (1978)	VM 34-166	3	2
TNT 440 F/C (1978)	VM 34-166	3	2
Everest 444 L/C	VM 34-150	4	1 1/2
Blizzard 6500	VM 34-184	4	1 1/2
Blizzard 9500	VM 36-78	4	1
Blizzard 5500	VM 34-203	3	1 1/2
Blizzard 7500 and Cross Country	VM 34-199	2	1 1/2

1. Remove air intake silencer.
2. Use a strong rubber band and clamp throttle lever to handlebar grip in the wide-open-throttle position.
3. Loosen locknut securing throttle slide adjuster. Feel inside carburetor bore and turn adjuster until cut-out portion of throttle valve is flush with inside of carburetor bore (Figure 44).
4. Turn adjuster sleeve counterclockwise the required number of additional turns to position the backside of the throttle valve flush with the carburetor bore.
5. Rotate idle speed screw counterclockwise until the tip is flush with inside of carburetor bore.
6. Remove rubber band clamp from handlebar and allow throttle to return to idle position.
7. Turn in idle speed screw until tip just contacts throttle slide valve. Turn in stop screw 2 additional turns for a preliminary idle setting.
8. Slowly operate throttle lever on handlebar

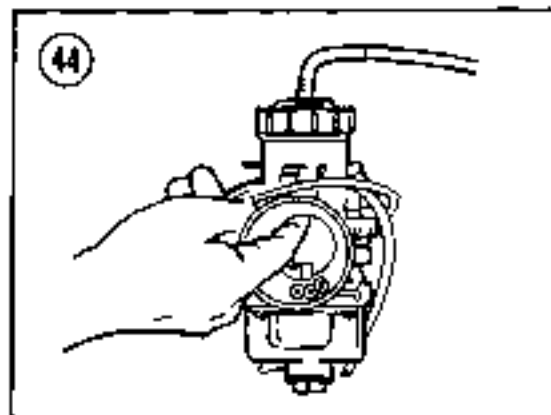

- and observe that throttle valve begins to rise. On models with 2 carburetors, ensure that throttle valves move an equal amount together. Readjust throttle cables if necessary.
9. Slowly turn in pilot air screw until light seating is felt. *Do not* force or air screw may be damaged. Back out pilot air screw number of turns specified in Table 8.

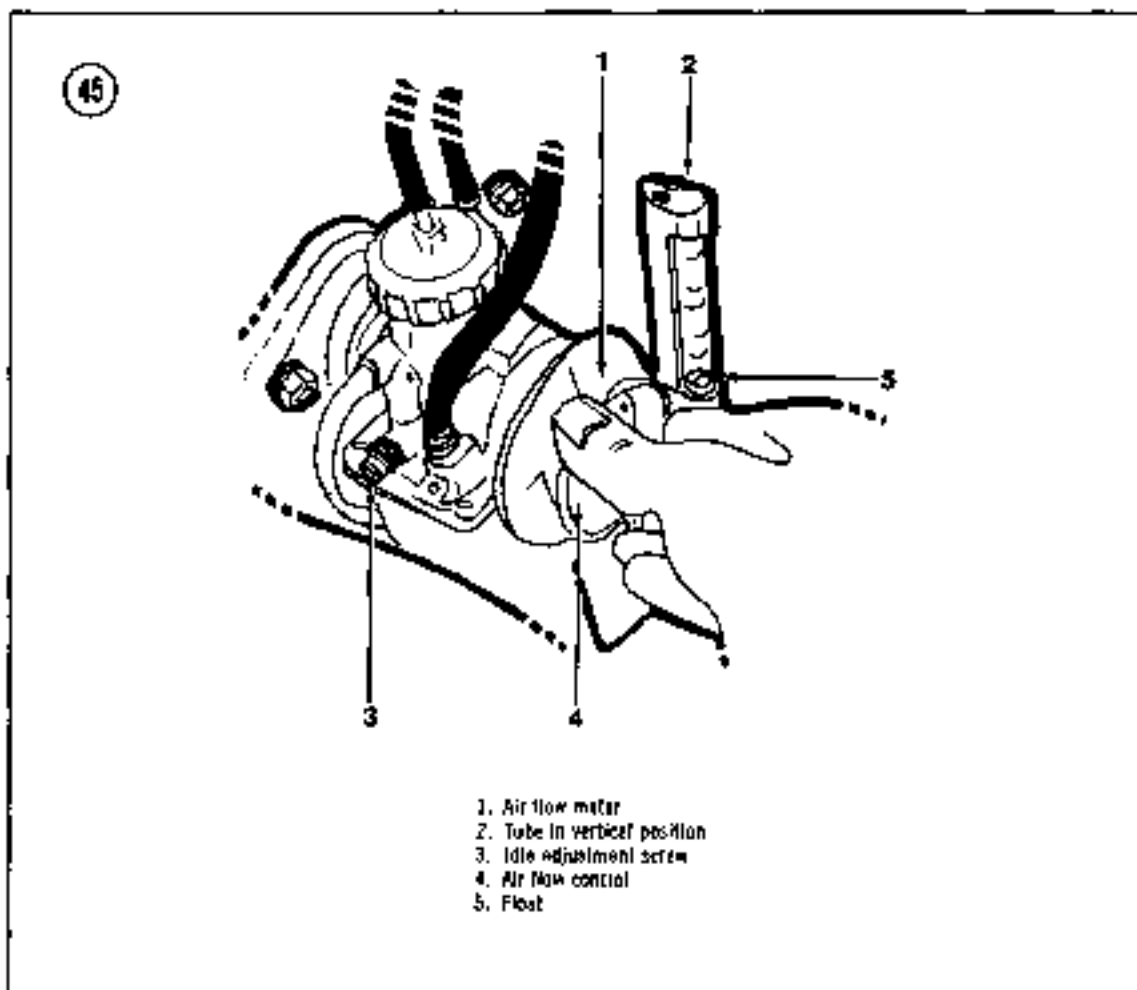

10. Install air intake silencer and start engine. Warm up engine to operating temperature and check idle speed. Adjust throttle stop screw as necessary for specified idle speed. On 2 carburetor models, ensure that both throttle stop screws are adjusted an equal amount.

CAUTION

Do not use pilot air screws to attempt to set engine idle speed. Pilot air screws must be set as specified in Table 8, or a "too lean" mixture and subsequent engine damage may result.

Mikuni Carburetor Air Flow Meter Synchronization

To obtain a precise synchronization of twin carburetor models, use an air flow meter device as described in Chapter One. Perform Mikuni

Carburetor Adjustment and Synchronization to obtain proper preliminary adjustments.

Refer to Figure 45 for this procedure.

WARNING

The following procedure is performed with the engine running. Ensure that arms and clothing are clear of drive belt or serious injury may result.

1. Raise and support rear of snowmobile so track is clear of the ground.
2. Start engine. Wedge in throttle lever to maintain engine speed at 4,000 rpm.
3. Open air flow control of air flow meter and place meter over right carburetor throat. Tube on meter must be vertical.
4. Slowly close air flow control until float in tube aligns with a graduated mark on tube.

- Without changing adjustment of air flow control, place air flow meter on left carburetor. If carburetors are equal, no adjustment is necessary.
- If adjustment is necessary, loosen cable adjuster locknut on carburetor with lowest float level and turn adjuster until air flow matches other carburetor. Tighten locknut.
- Return engine to idle and repeat Steps 3, 4, and 5. Adjust throttle stop screws as necessary for a balanced idle.

Main Jet Selection

The main jet controls the fuel metering when the carburetor is operating in the 1/2 to full throttle range. Since temperature and altitude affect the air density, each snowmobile owner will have to perform the following trial and error method of jet selection to obtain peak engine efficiency and performance for his own particular area of operation.

CAUTION

Air intake silencer must be installed during the following procedure or a "too lean" mixture may result. A "too lean" fuel mixture can cause engine overheating and subsequent serious damage.

NOTE: Snowmobile must be operated on a flat, well-paved area for best results.

- Operate machine at wide-open throttle for several minutes. If peak rpm cannot be achieved or engine appears to be laboring, main jet needs to be changed.
- Make another trial run and shut off ignition while throttle is still wide open. Examine the exhaust and spark plugs to determine if mixture is too rich or too lean. Mixture is too rich if exhaust manifold or spark plug insulator is dark brown or black. Refer to *Spark Plugs* in this chapter. Decrease jet size if mixture is too rich.

NOTE: Change jet sizes one increment at a time and rest after each change to obtain best results.

If manifold or spark plug insulator is a very light color, mixture is too lean. Correct by increasing jet size.

- If state of fuel/air mixture cannot be determined by color of exhaust manifold or spark plug insulator, assume mixture is too lean and increase jet size. If operation improves, continue increasing jet size until maximum performance is achieved. If operation gets worse, decrease jet size until best results are obtained.

OFF-SEASON STORAGE

Proper storage techniques are essential to help maintain your snowmobile's life and usefulness. The off-season is also an excellent time to perform any maintenance and repair tasks that are necessary.

Placing in Storage

- Use soap and water to thoroughly clean the exterior of your snowmobile. Use a hose to remove rocks, dirt, and debris from the track area. Clean all dirt and debris from the hood and console areas.

CAUTION

Do not spray water around the carburetor or engine. Be sure you allow sufficient time for all components to dry.

- Use a good automotive type cleaner wax and polish the hood, pan, and tunnel. Use a suitable type of upholstery cleaner on the seat. Touch up any scratched or bare metal parts with paint. Paint or oil the skis to prevent rust.
- Drain the fuel tank. Start the engine and run it at idle to burn off all fuel left in the carburetor. Check the fuel filter and replace if contaminated.
- Wrap up carburetor(s) and intake manifold in plastic and tie securely.
- Remove spark plugs and add a teaspoon of snowmobile oil to each cylinder. Pull the engine over several times with the starter rope to spread the oil over the cylinder walls. Replace the spark plugs.
- Remove the drive belt. Apply a film of light grease to drive and driven pulleys to prevent rust and corrosion.
- Change chaincase oil.

8. Raise rear of snowmobile off the ground. Loosen the track adjusting screws to remove any tension on the track.

9. Carefully examine all components and assemblies. Make a note of immediate and future maintenance and repair items and order the necessary parts. Perform *Hardware and Component Tightness Check*.

10. Cover snowmobile and store inside if possible.

Removing From Storage

1. Perform *Hardware and Component Tightness Check*.

2. Remove grease from the drive and driven

pulleys and install the drive belt.

3. Fill the fuel tank with new gasoline/oil mixture. Refer to Chapter One.

4. Check throttle and brake controls for proper operation and adjust if necessary.

5. Adjust the track to proper tension.

6. Familiarize yourself with all safety and operating instructions.

7. Start the engine and check the operation of the emergency stop switch. Check that all lights and switches operate properly. Replace any burned out bulbs.

8. Start out slowly on short rides until you are sure your machine is operating properly and is dependable.



CHAPTER THREE

TROUBLESHOOTING

Diagnosing snowmobile ills is relatively simple if you use orderly procedures and keep a few basic principles in mind.

Never assume anything. Do not overlook the obvious. If you are riding along and the snowmobile suddenly quits, check the easiest, most accessible problem spots first. Is there gasoline in the tank? Has a spark plug wire fallen off? Check the ignition switch. Maybe that last mogul caused you to accidentally switch the emergency switch to off or pull the emergency stop "rether" string.

If nothing obvious turns up in a cursory check, look a little further. Learning to recognize and describe symptoms will make repairs easier for you or a mechanic at the shop. Describe problems accurately and fully. Saying that "it won't run" isn't the same as saying "it quit at high speed and wouldn't start," or that "it sat in my garage for 3 months and then wouldn't start."

Garther as many symptoms together as possible to aid in diagnosis. Note whether the engine lost power gradually or all at once, what color smoke (if any) came from the exhaust, and so on. Remember that the more complicated a machine is, the easier it is to troubleshoot because symptoms point to specific problems.

You do not need fancy equipment or complicated test gear to determine whether repairs can

be attempted at home. A few simple checks could save a large repair bill and time lost while the snowmobile sits in a dealer's service department. On the other hand, be realistic and do not attempt repairs beyond your abilities. Service departments tend to charge heavily for putting together disassembled components that may have been abused. Some will not even take on such a job — so use common sense; do not get in over your head.

OPERATING REQUIREMENTS

An engine needs three basics to run properly: correct gas/air mixture, compression, and a spark at the right time. If one or more are missing, the engine will not run. The electrical system is the weakest link of the three. More problems result from electrical breakdowns than from any other source; keep this in mind before you begin tampering with carburetor adjustments.

If the snowmobile has been sitting for any length of time and refuses to start, check the battery (if the machine is so equipped) for a charged condition first, and then look to the gasoline delivery system. This includes the tank, fuel petcocks, lines, and the carburetor. Rust may have formed in the tank, obstructing fuel flow. Gasoline deposits may have gummed up

carburetor jets and air passages. Gasoline tends to lose its potency after standing for long periods. Condensation may contaminate it with water. Drain old gas and try starting with a fresh tankful.

Compression, or the lack of it, usually enters the picture only in the case of older machines. Worn or broken pistons, rings, and cylinder bores could prevent starting. Commonly, a gradual power loss and harder and harder starting will be readily apparent in this case.

PRINCIPLES OF 2-CYCLE ENGINES

The following is a general discussion of a typical 2-cycle piston-ported engine. The same principles apply to rotary valve engines except that during the intake cycle, the fuel/air mixture passes through a rotary valve assembly into the crankcase. During this discussion, assume that the crankshaft is rotating counterclockwise.

In **Figure 1**, as the piston travels downward, a scavenging port (A) between the crankcase and the cylinder is uncovered. Exhaust gases leave the cylinder through the exhaust port (B), which is also opened by downward movement of the piston. A fresh fuel/air charge, which has previously been compressed slightly, travels from the crankcase (C) to the cylinder through scavenging port (A) as the port opens. Since the incoming charge is under pressure, it rushes into the cylinder quickly and helps to expel exhaust gases from the previous cycle.

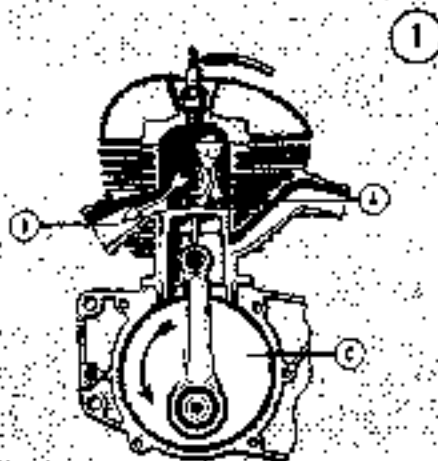
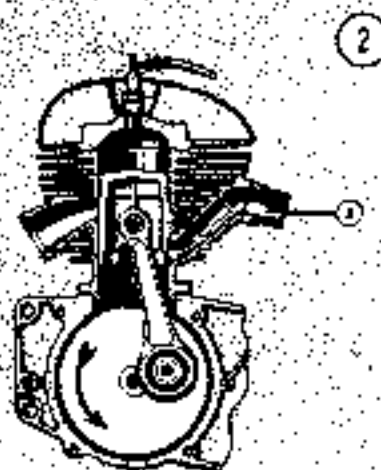

Figure 2 illustrates the next phase of the cycle. As the crankshaft continues to rotate, the piston moves upward, closing the exhaust and scavenging ports. As the piston continues upward, the air/fuel mixture in the cylinder is compressed. Notice also that a low pressure area is created in the crankcase at the same time. Further upward movement of the piston uncovers intake port (D). A fresh fuel/air charge is then drawn into the crankcase through the intake port because of the low pressure created by the upward piston movement.



The third phase is shown in **Figure 3**. As the piston approaches top dead center, the spark plug fires, igniting the compressed mixture. The piston is then driven downward by the expanding gases.

When the top of the piston uncovers the exhaust port, the fourth phase begins, as shown in **Figure 4**. The exhaust gases leave the cylinder through the exhaust port. As the piston continues downward, the intake port is closed and the mixture in the crankcase is compressed in preparation for the next cycle. Every downward stroke of the piston is a power stroke.

ENGINE STARTING

An engine that refuses to start or is difficult to start can try anyone's patience. More often than not, the problem is very minor and can be

3

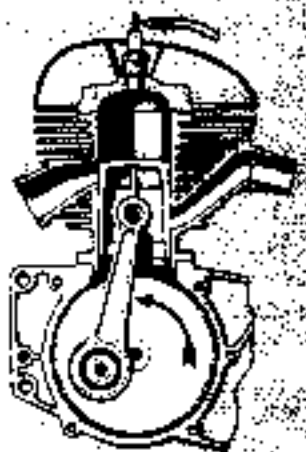

4

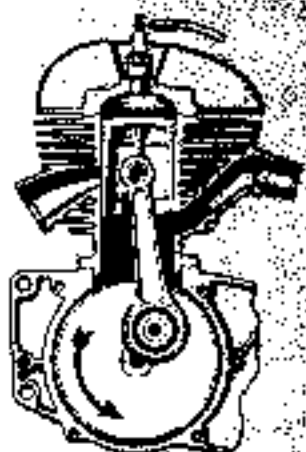

found with a simple and logical troubleshooting approach.

The following items provide a beginning point from which to isolate an engine starting problem.

Engine Fails to Start

Perform the following spark test to determine if the ignition system is operating properly.

1. Remove a spark plug.
2. Connect spark plug connector to spark plug and clamp base of spark plug to a good grounding point on the engine. A large alligator clip makes an ideal clamp. Position spark plug so you can observe the electrode.

3. Turn on ignition and crank engine over. A fat blue spark should be evident across spark plug electrode.

WARNING

On machines equipped with CDI (capacitor discharge ignition), do not hold spark plug, wire, or connector or a serious electrical shock may result.

4. If spark is good, check for one or more of the following possible malfunctions:
 - a. Fouled or defective spark plugs
 - b. Obstructed fuel filter or fuel line
 - c. Defective fuel pump
 - d. Leaking head gasket (see *Compression Test*)
5. If spark is not good, check for one or more of the following:
 - a. Burned, pitted, or improperly gapped breaker points
 - b. Weak ignition coil or condenser
 - c. Loose electrical connections
 - d. Defective cut components — have cut system checked by an authorized dealer.

Engine Difficult to Start

Check for one or more of the following possible malfunctions:

- a. Fouled spark plugs
- b. Improperly adjusted choke
- c. Defective or improperly adjusted breaker points
- d. Contaminated fuel system
- e. Improperly adjusted carburetor
- f. Weak ignition coil
- g. Incorrect fuel mixture
- h. Defective reed valve
- i. Crankcase drain plugs loose or missing
- j. Poor compression (see *Compression Test*)

Engine Will Not Crank

Check for one or more of the following possible malfunctions:

- a. Defective recoil starter
- b. Seized piston
- c. Seized crankshaft bearings
- d. Broken connecting rod

Compression Test

Perform compression test to determine condition of piston ring sealing qualities, piston wear, and condition of head gasket seal.

1. Remove spark plugs. Insert a compression gauge in one spark plug hole (Figure 5). Refer to Chapter One for a suitable type of compression tester.

2. Crank engine vigorously and record compression reading. Repeat for other cylinder. Compression readings should be from 120-175 psi (8.4-12.30 kg/cm²). Maximum allowable variation between cylinders is 10 psi (0.70 kg/cm²).

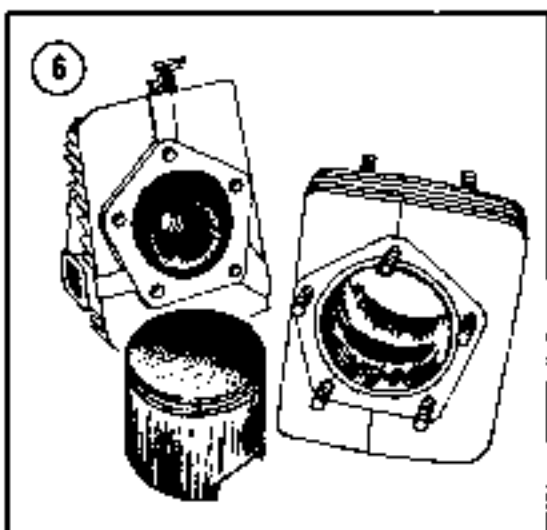

3. If compression is low or variance between cylinders is excessive, check for defective head gaskets, damaged cylinders and pistons, or stuck piston rings.

ENGINE PERFORMANCE

In the following discussion, it is assumed that the engine runs, but is not operating at peak efficiency. This will serve as a starting point from which to isolate a performance malfunction.

The possible causes for each malfunction are listed in a logical sequence and in order of probability.

Engine Will Not Idle

- a. Carburetor incorrectly adjusted
- b. Fouled or improperly gapped spark plugs
- c. Head gasket leaking — perform compression test
- d. Fuel mixture incorrect
- e. Spark advance mechanism not retarding
- f. Obstructed fuel pump impulse tube
- g. Crankcase drain plugs loose or missing

Engine Misses at High Speed

- a. Fouled or improperly gapped spark plugs
- b. Defective or improperly gapped breaker points
- c. Improper ignition timing
- d. Defective fuel pump
- e. Improper carburetor high-speed adjustment (Walbro and Bendix carburetors) or improper main jet selection (Mikuni carburetor)
- f. Weak ignition coil
- g. Obstructed fuel pump impulse tube

Engine Overheating

- a. Too lean fuel mixture — incorrect carburetor adjustment or jet selection
- b. Improper ignition timing
- c. Incorrect spark plug heat range
- d. Intake system or crankcase air leak
- e. Cooling fan belt or coolant pump drive belt broken or slipping
- f. Cooling fan or coolant pump defective
- g. Leak in liquid cooling system
- h. Damaged or blocked cooling fins

Smoky Exhaust and Engine Runs Rough

- Carburetor adjusted incorrectly — mixture too rich
- Incorrect fuel/oil mixture
- Choke not operating properly
- Obstructed muffler
- Water or other contaminants in fuel

Engine Loses Power

- Carburetor incorrectly adjusted
- Engine overheating
- Defective or improperly gapped breaker points
- Improper ignition timing
- Incorrectly gapped spark plugs
- Weak ignition coil
- Obstructed muffler
- Defective reed valve

Engine Lacks Acceleration

- Carburetor mixture too lean
- Defective fuel pump
- Incorrect fuel/oil mixture
- Defective or improperly gapped breaker points
- Improper ignition timing
- Defective rotary valve

ENGINE FAILURE ANALYSIS

Overheating is the major cause of serious and expensive engine failures. It is important that each snowmobile owner understand all the causes of engine overheating and take the necessary precautions to avoid expensive overheating damage. Proper preventive maintenance and careful attention to all potential problem areas can often eliminate a serious malfunction before it happens.

Fuel

All Ski-Doo snowmobile engines rely on a proper fuel/oil mixture for engine lubrication. Always use an approved oil and mix the fuel carefully as described in Chapter One.

Gasoline must be of sufficiently high octane (90 or higher) to avoid "knocking" and "detonation."

Fuel/Air Mixture

Fuel/air mixture is determined by carburetor adjustment (Tillotson) or main jet selection (Mikuni). Always adjust carburetors carefully and pay particular attention to avoiding a "too lean" mixture.

Heat

Excessive external heat on the engine can be caused by the following:

- Hood louvers plugged with snow
- Damaged or plugged cylinder and head cooling fins
- Slipping or broken fan belt
- Damaged cooling fan or coolant pump
- Operating snowmobile in hot weather
- Plugged or restricted exhaust system

See Figures 6 and 7 for examples of cylinder and piston scuffing caused by excessive heat.

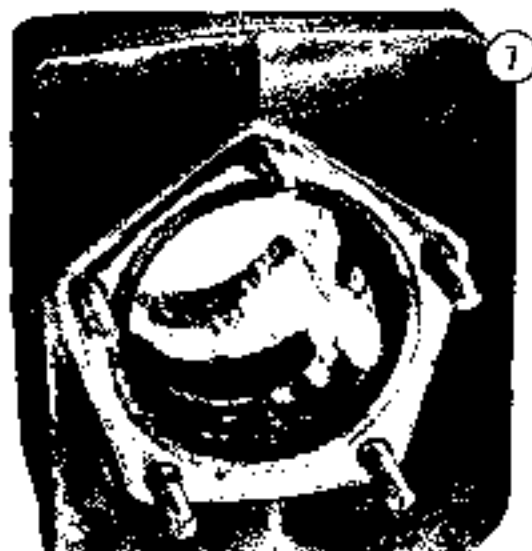
**Dirt**

Dirt is a potential problem for all snowmobiles. The air intake silencers on all models are not designed to filter incoming air. Avoid running snowmobiles in areas that are not completely snow covered.

Ignition Timing

Ignition timing that is too far advanced can cause "knocking" or "detonation." Timing that is too retarded causes excessive heat buildup in the cylinder exhaust port areas.

Spark Plugs

Spark plugs must be of a correct heat range. Too hot a heat range can cause preignition and detonation which can ultimately result in piston burn-through as shown in Figure 8.

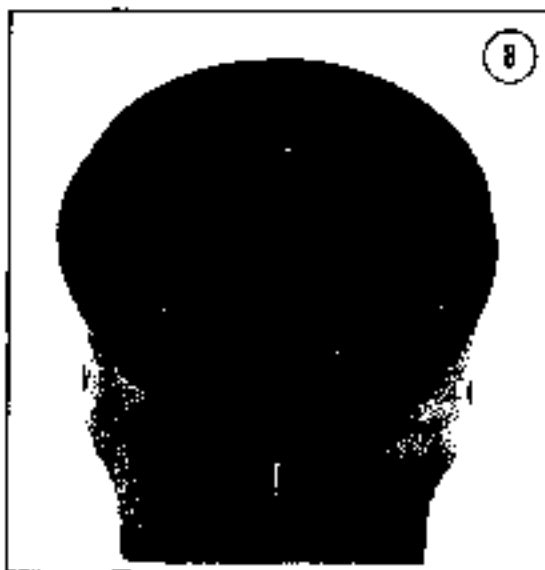

Refer to Chapter Two for recommended spark plugs.

Preignition

Preignition is caused by excessive heat in the combustion chamber due to a spark plug of improper heat range and/or too lean a fuel mixture. See Figure 9 for an example of a melted and scuffed piston caused by preignition.

Detonation (Knocking)

Knocking is caused by a "too lean" fuel mixture and/or "too low" octane fuel.

ELECTRICAL SYSTEM

The following items provide a starting point from which to troubleshoot electrical system malfunctions. The possible causes for each

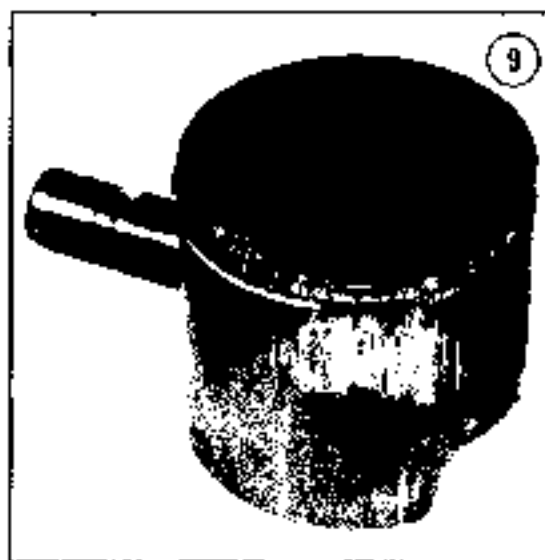

malfunction are listed in a logical sequence and in order of probability.

Ignition system malfunctions are outlined under *Engine Starting* and *Engine Performance*, covered earlier.

Lights Will Not Light

- Bulbs are burned out
- Loose electrical connections
- Defective switch
- Defective lighting coil

Bulbs Burn Out Rapidly

Incorrect bulb type

Lights Too Bright or Too Dim

Defective lighting coil

Discharged Battery

- Defective battery
- Low electrolyte level
- Dirty or loose electrical connections
- Defective lighting coil
- Defective rectifier

Cracked Battery Case

- Discharged battery allowed to freeze
- Improperly installed hold-down clamp
- Improperly attached battery cables

Starter Motor Does Not Operate

- Loose electrical connections
- Discharged battery
- Defective starter solenoid
- Defective starter motor
- Defective ignition switch

Poor Starter Performance

- Commutator or brushes worn, dirty, or oil soaked
- Binding armature
- Weak brush springs
- Armature open, shorted, or grounded

POWER TRAIN

The following items provide a starting point from which to troubleshoot power train malfunctions. The possible causes for each malfunction are listed in order of probability. Also refer to *Drive Belt Wear Analysis*, later in this chapter.

Drive Belt Not Operating Smoothly in Drive Pulley

- Face of drive pulley is rough, grooved, pitted, or scored
- Defective drive belt

Uneven Drive Belt Wear

- Misaligned drive and driven pulleys
- Loose engine mounts

Glazed Drive Belt

- Excessive slippage
- Oil on pulley surfaces

Drive Belt Worn Narrow in One Place

- Excessive slippage caused by stuck track
- Too high engine idle speed

Drive Belt Too Tight at Idle

- Engine idle speed too fast
- Distance between pulley incorrect
- Belt length incorrect

Drive Belt Edge Cord Failure

- Misaligned pulleys
- Loose engine mounting bolts

Brake Not Holding Properly

- Incorrect brake cable adjustment or air in hydraulic brake system
- Brake lining or pads worn
- Oil saturated brake lining or pads
- Sheared key on brake pulley or disc

Brake Not Releasing Properly

- Weak or broken return spring
- Bent or damaged brake lever

Leaking Chaincase

- Gaskets on drive shaft bearing flange
- Cracked or broken chaincase

Rapid Chain and Sprocket Wear

- Insufficient chaincase oil
- Misaligned sprockets
- Broken chain tension blocks

DRIVE BELT WEAR ANALYSIS**Uneven Belt Wear**

Uneven belt wear on only one side as shown in **Figure 10** is usually caused by a loose engine mount or pulley misalignment. Also check for rough or scratched pulley surfaces.

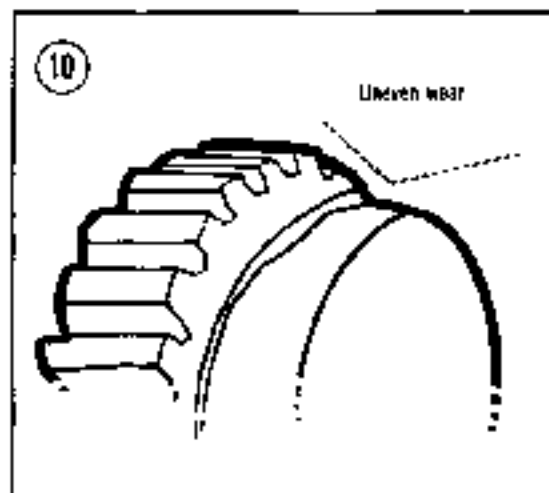

Glazed Belt

A glazed or baked appearance on the edge of the belt as shown in **Figure 11** is usually the result of some mechanical difficulty. Pulley shafts may be rusted or the drive pulley may have worn or missing flyweights/rollers. Refer this type of belt wear to a dealer. He has the expertise to pinpoint the malfunction.

Worn Top Width

Excessive wear in the top width of the belt (**Figure 12**) can be caused by erratic drive pulley

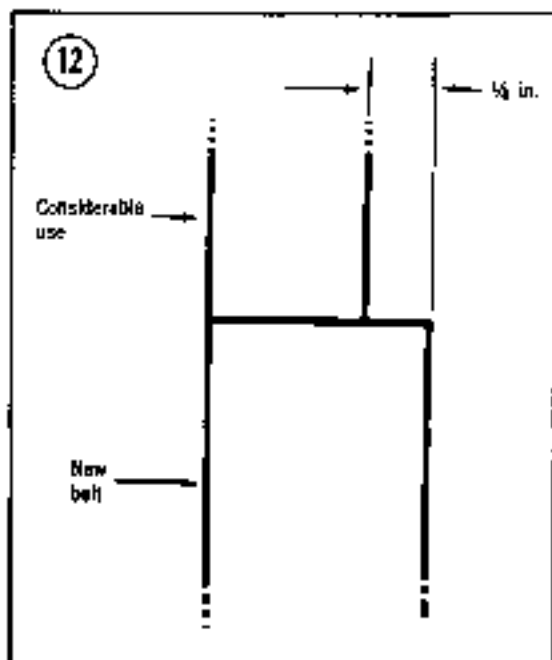
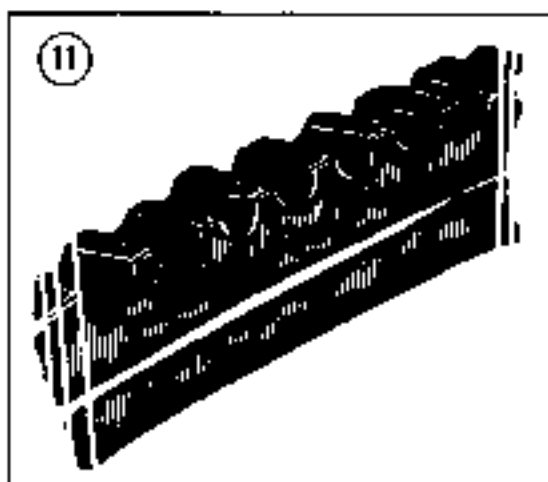

actuation or rough or scratched pulley surfaces. If all mechanical systems are functioning properly, the belt may just be worn out. Replace drive belt if its width is $\frac{1}{8}$ in. (3mm) less than new. Refer to Chapter Seven.

Belt Worn in One Section

Spot wear such as shown in **Figure 13** is often caused by a frozen or too tight track. Check also for a too high idle speed, incorrect belt length, incorrect pulley distance, or a malfunction in the drive pulley.

Belt Edges Worn Concave

Concave edge wear as shown in **Figure 14** is caused by using an improper drive belt or roughness on pulley surfaces.

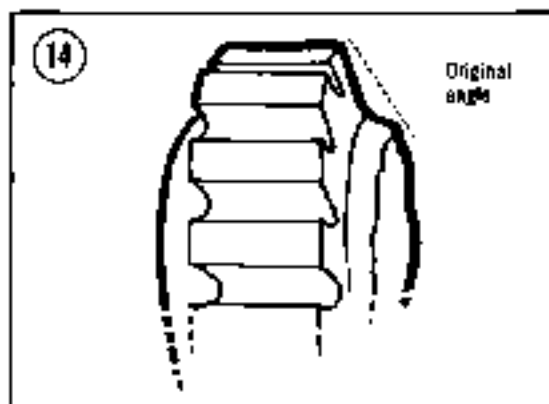
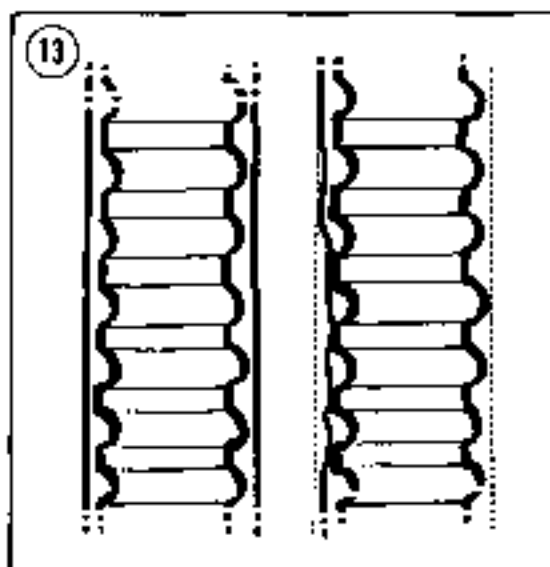

Belt Disintegration

Belt disintegration as illustrated in **Figure 15** is the result of excessive belt speed caused by using an improper drive belt or oil on pulley surfaces. Incorrect gear ratio may also cause belt disintegration. Refer malfunction to a dealer for his analysis.

Edge Cord Breakage

The type of edge cord breakage shown in **Figure 16** is usually caused by pulley misalignment. Refer to Chapter Seven for applicable pulley alignment procedure.

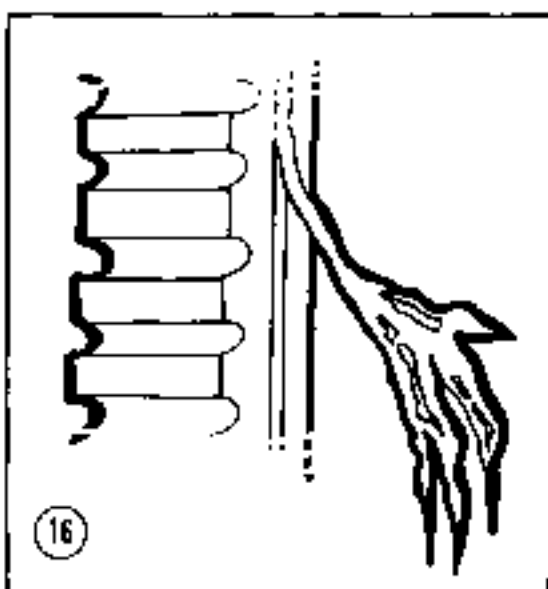
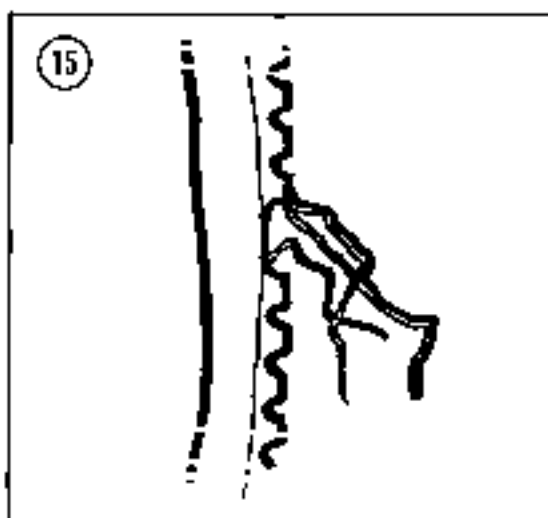

Flex Crack Between Cogs

Cracks appearing between belt cogs (**Figure 17**) generally indicate that the belt has lost its flexibility and must be replaced.

Sheared Drive Cogs

Sheared cogs as shown in **Figure 18** can be a result of improper belt installation as well as violent erratic drive pulley engagement. Enlist the help of a dealer to determine the full nature of the malfunction.

Belt "Flip-Over"

Drive belt "flip-over" at high speed (**Figure 19**) is usually caused by improper pulley alignment. Also check that the belt is the exact type specified for your machine.

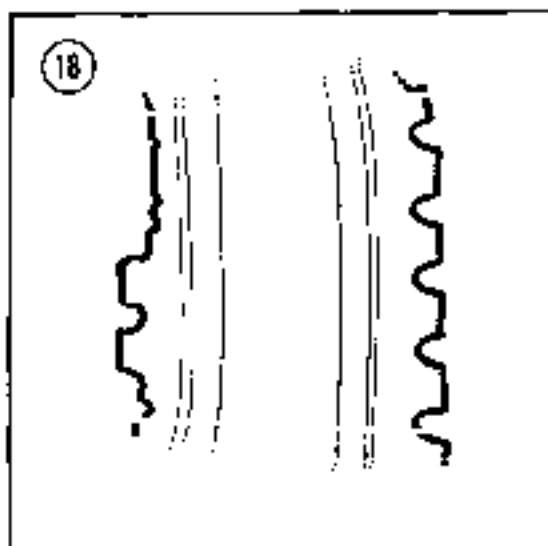
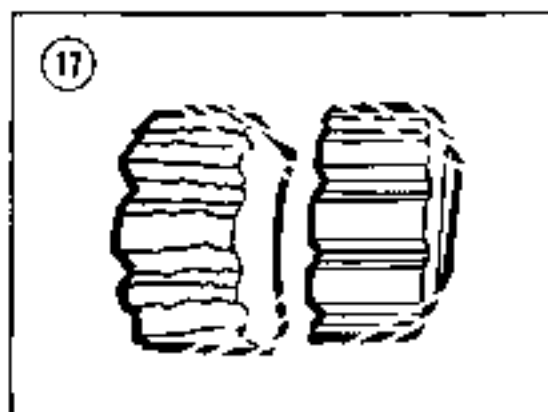

SKIS AND STEERING

The following items provide a starting point from which to troubleshoot ski and steering malfunctions. The possible causes for each malfunction are listed in order of probability.

Loose Steering

- Loose steering post bushing
- Loose tie rod ends
- Worn spindle bushings
- Stripped spindle splines

Unequal Steering

- Improperly adjusted tie rods
- Improperly installed steering arms

Rapid Ski Wear

- Skis misaligned
- Worn out ski runner shoes

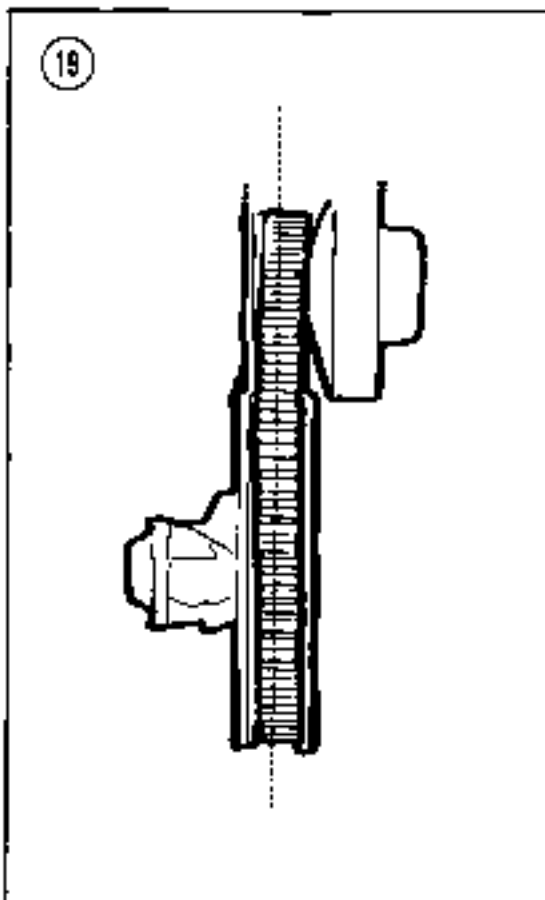

TRACK ASSEMBLY

The following items provide a starting point from which to troubleshoot track assembly malfunctions. The possible causes for each malfunction are listed in order of probability.

Frayed Track Edge

Track is misaligned.

Track Grooved on Inner Surface

- Track too tight
- Frozen bogie wheel(s)
- Frozen rear idle-shaft bearing

Track Driving Ratcheting

Track is too loose.

Rear Idlers Turning on Shaft

Rear idler shaft bearings are frozen.

Bogie Wheels Not Turning Freely

Bogie wheel bearing is defective.

Bogie Assemblies Not Pivoting Freely

Bogie tube and axle are bent.

TRACK WEAR ANALYSIS

The majority of track failures and abnormal wear patterns are caused by negligence, abuse, and poor maintenance. The following items illustrate typical examples. In all cases the damage could have been avoided by proper maintenance and good operator technique.

Obstruction Damage

Cuts, slashes, and gouges in the track surface are caused by hitting obstructions such as broken glass, sharp rocks, or buried steel. See Figure 20.

Worn Grouser Bars

Excessively worn grouser bars are caused by snowmobile operation over rough and non-snow covered terrain such as gravel roads and highway roadsides (Figure 21).

Lug Damage

Lug damage as shown in **Figure 22** is caused by lack of snow lubrication.

Ratcheting Damage

Insufficient track tension is a major cause of ratcheting damage to the top of the lugs. See **Figure 23**. Ratcheting damage can also be caused by too great a load and constant "jack-rabbit" starts.

Overextension Damage

Excessive track tension can cause too much friction on the wear bars. This friction causes the wear bars to melt and adhere to the track grouser bars. See **Figure 24**. An indication of this condition is a "sticky" track that has a tendency to "lock up."

Loose Track Damage

A track adjusted too loosely can cause the outer edge to flex excessively. This results in the

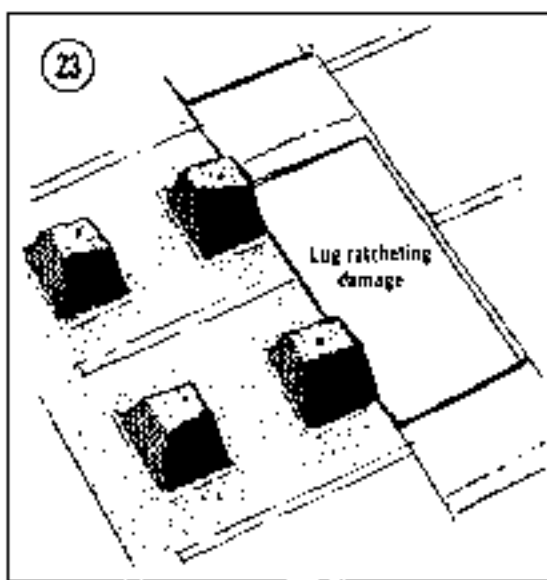
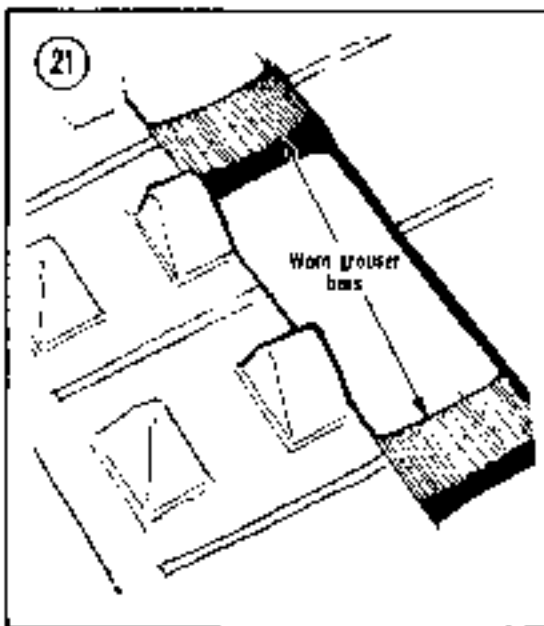
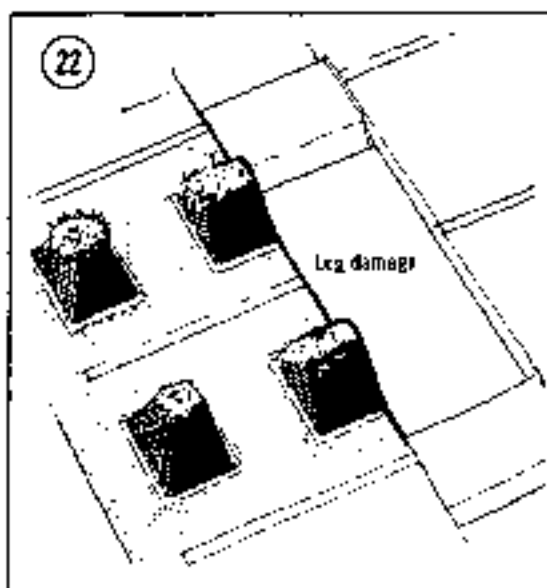
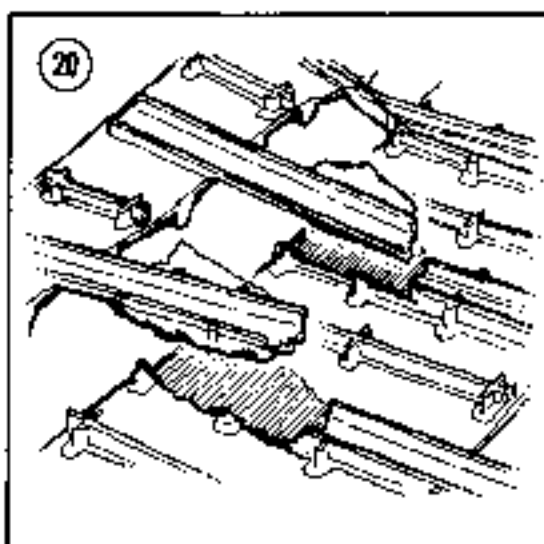

type of damage shown in Figure 25. Excessive weight can also contribute to the damage.

Impact Damage

Impact damage as shown in Figure 26 causes the track rubber to open and expose the cord. This frequently happens in more than one place. Impact damage is usually caused by riding on rough or frozen ground or ice. Insuf-

ficient track tension can allow the track to pound against the track stabilizers inside the tunnel.

Edge Damage

Edge damage as shown in Figure 27 is usually caused by tipping the snowmobile on its side to clear the track and allowing the track edge to contact an abrasive surface

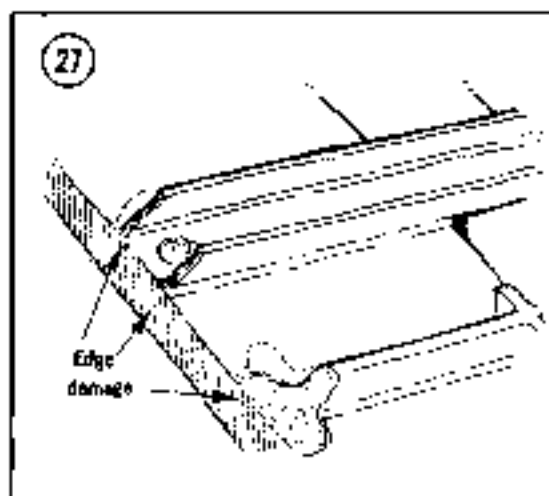
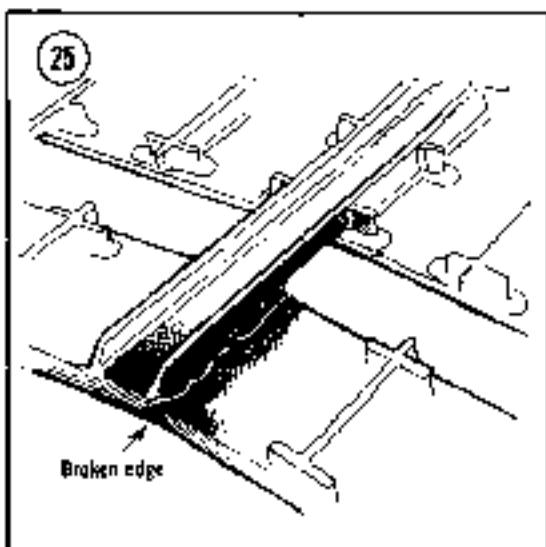
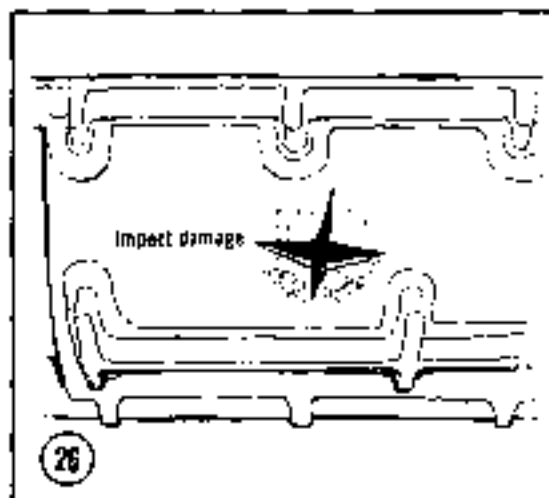
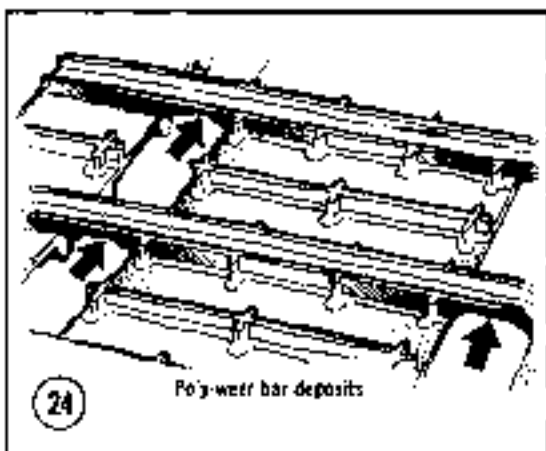

CHAPTER FOUR

ENGINE

Ski-Doo snowmobiles are equipped with single and twin cylinder 2-cycle engines. The high performance twin cylinder engines are equipped with rotary valves, all other engines use piston-ported.

All engines have ball or roller main crankshaft bearings and needle bearings on the lower and upper bearings of the connecting rods.

This chapter includes removal and repair procedures for most engine components. However, due to the special tools and expertise required, all crankshaft assembly inspection and alignment should be performed by an authorized dealer or competent machine shop. Some procedures in this chapter require the use of special tools. In all cases the special tools are illustrated and in many cases can be easily fabricated or substituted by a well-equipped home mechanic. However, each snowmobile owner must be honest with himself about his own supply of tools and expertise and avoid repair procedures that are not within his capabilities. It is often cheaper and easier in the long run to remove the engine and take it to an authorized dealer for required service and repair than to risk expensive damage if you do not have the proper tools and facilities for the necessary work.

TOP END AND COMPLETE OVERHAUL

The following is an orderly sequence for removing and disassembling the engine to perform a top end overhaul or complete overhaul. Proceed to the applicable engine section and perform the procedures necessary in the order indicated to achieve desired level of disassembly for the necessary repairs. Tightening torques (Table 1), single cylinder engine specifications (Table 2), and twin cylinder engine specifications (Table 3) are found at the end of the chapter.

Top End Overhaul

- a. Remove engine.
- b. Remove fan housing and shrouds.
- c. Remove flywheel and magneto assembly.
- d. Remove cylinder head.
- e. Remove cylinder, piston, and rings.
- f. Perform component inspection.

Complete Overhaul

- a. Perform top end overhaul.
- b. Remove crankshaft assembly.
- c. Perform component inspection.

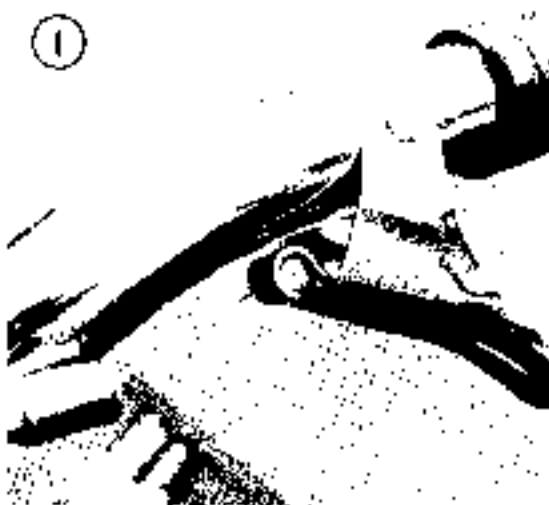

SINGLE CYLINDER ENGINES

Engine Removal/Installation

1. Disconnect brake and throttle cables and cable housings from handlebar and brake lever (Figure 1). On Flan models disconnect cable from handle plate and remove cable from engine bracket. Disconnect throttle cable from carburetor. Remove choke knob if necessary.
2. On all models except TNT, remove console.
3. Remove pulley guard and drive belt as outlined in Chapter Seven.
4. Disconnect fuel lines from carburetor (Figure 2). Position lines up higher than level of tank to prevent tank from draining.
5. Disconnect all electrical connectors from engine. Tag wire locations to aid installation.
6. On electric start models, disconnect negative battery cable and disconnect solenoid and starter wires (Figure 3).
7. On applicable models, disconnect decompressor (compression release) knob from decompressor, and remove decompressor switch from holder.
8. Disconnect steering column from upper column as shown in Figure 4.
9. Remove engine mounting nuts and washers (Figure 5).
10. On Flan and TNT models perform the following:
 - a. Tilt upper column towards seat.
 - b. Raise steering column and lift engine out from right side of machine.

11. On Olympique models, proceed as follows:
 - a. Remove upper column.
 - b. Remove engine from right side of machine.
12. Installation is the reverse of these steps. Keep the following points in mind:
 - a. Torque nuts securing engine assembly as specified in **Table 1**.
 - b. Adjust decompressor cable for $\frac{1}{8}$ in. (1.6mm) free play between cable housing ferrule and valve lever (**Figure 6**).
 - c. Adjust brakes as outlined in Chapter Two.
 - d. Perform *Pulley Alignment* as outlined in Chapter Seven.



Exterior Component Removal/Installation

1. Remove air silencer, carburetor, and muffler.
2. Remove recoil starter and drive pulley.
3. Remove throttle cable bracket secured to engine. On models with 247cc engine, remove brake cable bracket from engine.
4. Remove electric starter on models so equipped.
5. Remove decompressor valve (compression release) from cylinder on models so equipped.
6. Remove engine mount from crankcase.
7. Installation is the reverse of these steps. Keep the following points in mind:
 - a. Lower left screw in recoil starter on Olympique 335 E models also secures battery cable clamp.
 - b. Torque decompressor valve to 10 ft.-lb. (1.4 mkg) and secure valve to cylinder by bending a section of locking and sealing sleeve over cylinder fin.
 - c. Torque nuts securing engine mount to crankcase as specified in **Table 1**.
 - d. When installing carburetor, assemble components in the following order: flange gasket, isolating flange, flange gasket, isolating sleeves, carburetor, isolating washers and nuts.

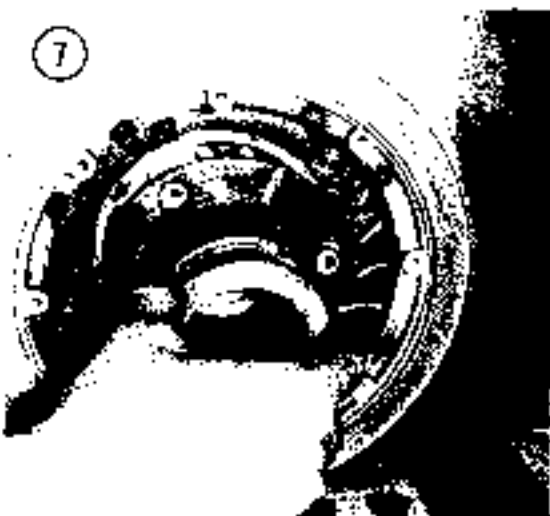

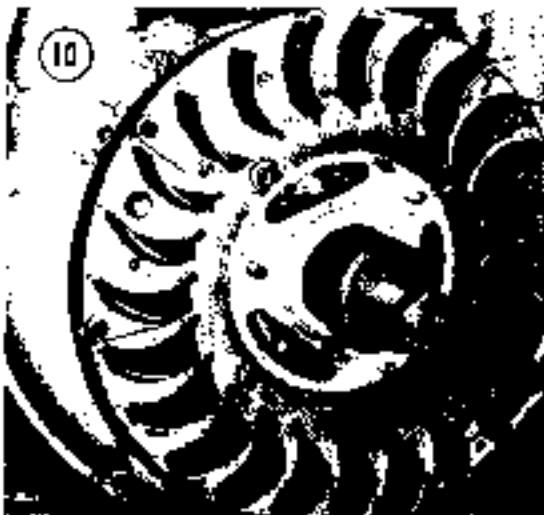
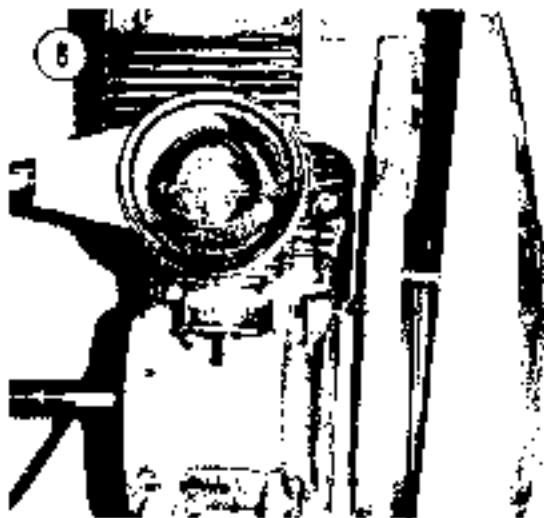

NOTE: Be sure that the hole in plastic flange aligns with vacuum port on engine flange.

Fan Cowl, Fan, and Magneto Assembly Removal/Installation

The following procedure requires the use of special tools to remove magneto plate/fan assembly. If special tools or locally fabricated equivalents are not available, refer task to an authorized dealer.

1. Remove engine and recoil starter.
2. Remove electric starter on models so equipped.
3. Remove nuts securing starting pulley to magneto plate (Figure 7) and remove pulley.
4. Remove fan cowl assembly from engine (Figure 8).
5. Using a hammer and small punch, bend back locking tab securing magneto nut.
6. Using special tool to hold fan, remove nut and washer securing magneto plate/fan housing assembly as shown in Figure 9.
7. Install special puller and tighten until magneto plate/fan assembly is removed from crankshaft (Figure 10).

CAUTION

Always place magneto ring on a clean cloth or magneto may attract dirt and/or metal particles that can affect magneto efficiency.

NOTE: At this time electric starter gear or magneto plate can be removed from fan assembly if desired.

8. Remove screws securing labyrinth ring to magneto assembly and remove ring (Figure 11).
9. Using a hammer and small punch, gently remove Woodruff key from crankshaft.

CAUTION

Exercise care when key is removed or key and/or crankshaft may be damaged.

10. Remove cam spring and washers from end of crankshaft (Figure 12).
11. Remove Allen screws securing magneto armature plate to engine (Figure 13). Disconnect wiring and remove armature plate. Tag wires to aid connection during installation.

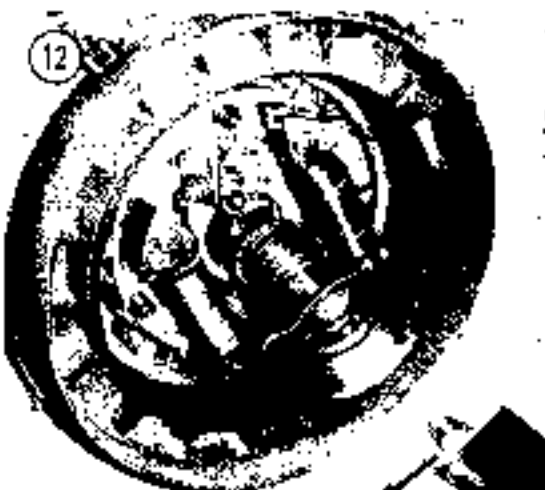

12. On electric start and T-1NF 292 models, remove screws securing ignition coil and bracket and remove coil and bracket from engine.

13. Installation is the reverse of these steps. Keep the following points in mind:

CAUTION

Ensure that magneto wires are correctly positioned to avoid their being squeezed behind armature plate.

- Lightly grease inner channel of cam with low temperature grease.
- Be sure bevelled side of labyrinth ring is on top (Figure 14).
- Lightly grease spring seating of magneto ring plate with low temperature grease

d. Turn crankshaft until Woodruff key is up and rotate cam until it is approximately 240° from key.

e. Torque magneto nut. See Table 1.

f. Perform engine timing as outlined in Chapter Two.

Cylinder Head, Cylinder, Piston, and Ring Removal

- Remove engine and external components.
- Remove fan and magneto assembly.
- Remove nuts securing cylinder head (see Figure 15). To aid head removal, gently tap head with a rubber mallet. Remove head and discard old gasket.
- Gently slide cylinder up over piston (Figure 16).

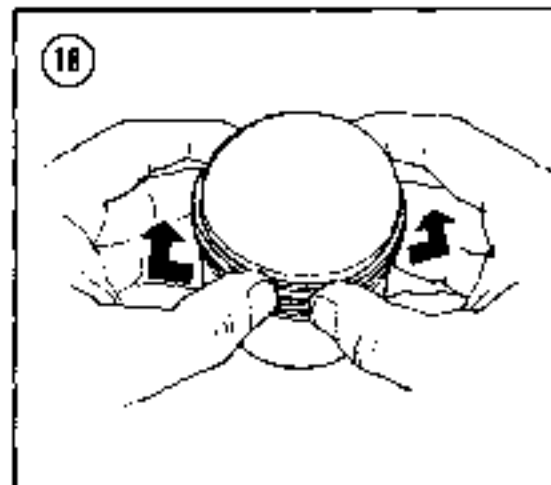
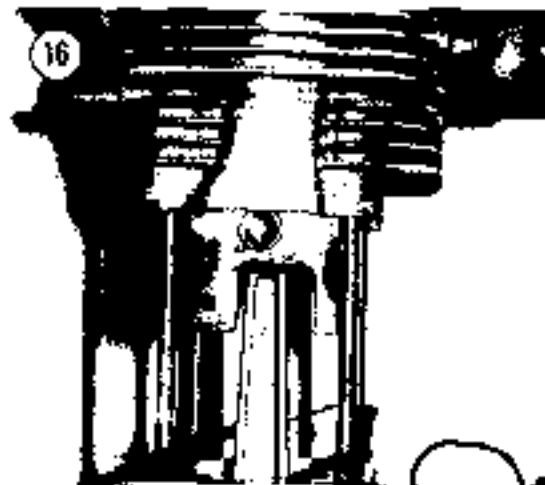
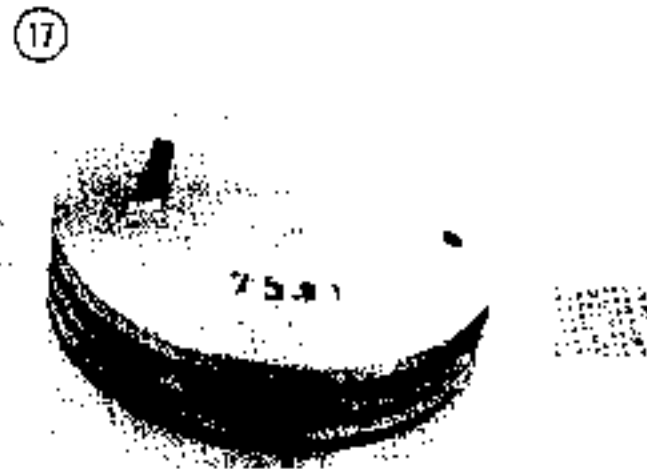

5. Note mark on piston indicating exhaust side of engine (Figure 17). If no marks are visible, inscribe piston accordingly.

NOTE: If rings are going to be changed, but not piston, rings may now be removed. However if piston is going to be removed, leave old rings on piston to protect ring grooves until new rings are to be installed.

6. Using a ring expander tool or your thumbs on each end of piston ring, gently expand ring and slide up and off piston. (Figure 18).

7. Be sure piston is appropriately marked. Remove circlips from each end of piston pin (Figure 19).

NOTE: Stuff clean rags around connecting rod in crankcase to help prevent circlips from dropping into crankcase.

Using a piston pin removal tool or an appropriately sized wooden dowel, gently remove pin from piston and connecting rod.

CAUTION

Exercise care when removing pin to avoid damaging connecting rod needle bearings. If a wooden dowel is used to drive out piston pin, ensure that piston is properly supported so that lateral shock is not transmitted to lower connecting rod bearing, otherwise rod and/or bearing damage may occur.

Remove needle bearing from connecting rod.

8. Refer to *Component Inspection* and inspect cylinder, piston, pin, and rings.

Cylinder Head, Cylinder, Piston, and Ring Installation

1. Lubricate piston pin needle bearings with oil and insert bearings into connecting rod.
2. Slide piston over connecting rod. Be sure that mark or letters *ACB* face exhaust side of engine (Figure 17).
3. Using piston pin installation tool or appropriately sized wooden dowel, install piston pin through piston and rod end.

CAUTION

Exercise care when installing pin to avoid damage to connecting rod needle bearing. If a wooden dowel is used to drive in piston pin, ensure that piston is properly supported so that lateral shock is not transmitted to lower connecting rod bearing, otherwise rod and/or bearing damage may occur.

4. Secure piston pin to piston with circlips. When circlip is properly installed in groove, rotate circlip so gap in clip is not directly on notch break of piston (Figure 19).

NOTE: *Stuff clean rags around connecting rod in crankcase to help prevent circlip from dropping into crankcase.*

CAUTION

If possible use new circlips to secure piston pin. If old circlips are used they must snap securely into grooves in piston. A weak circlip could become disengaged during engine operation and cause severe engine damage.

5. Using a ring expander tool or your thumbs on each end of piston ring, gently expand ring and slide over piston in ring groove (Figure 18). Install ring in bottom groove first. Be sure that ring groove clearance is within tolerance as outlined in *Component Inspection*.

NOTE: *Be sure that ring end "V" is properly positioned in ring groove.*

6. Install new cylinder base gasket.
7. Thoroughly lubricate piston, rings, and cylinder bore with engine oil.

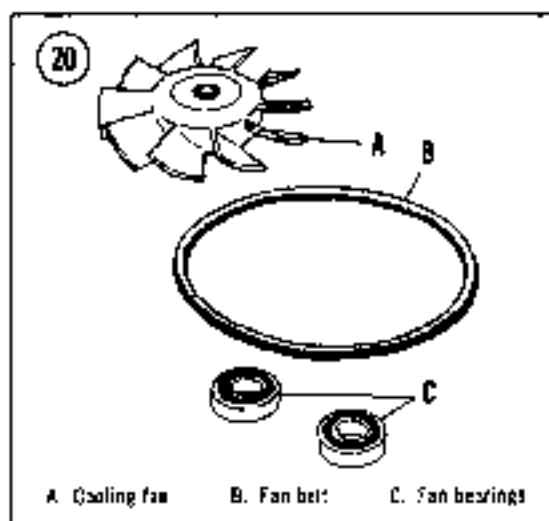
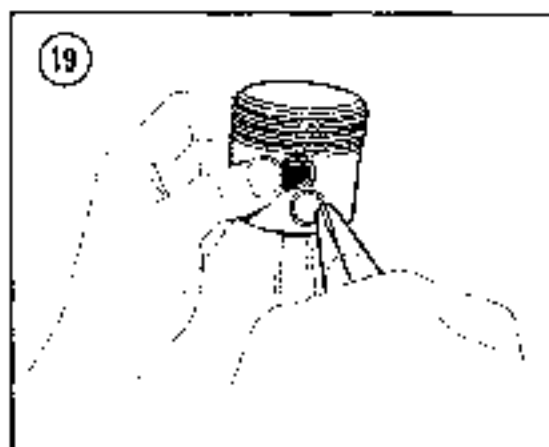

8. Position 2 thin, wooden supports such as tongue depressors under piston for piston support, and rotate crankshaft so that piston sits on wooden supports.

9. Compress rings with a suitable ring compressor or your fingers and carefully slide cylinder down over piston.

CAUTION

Crankshaft, connecting rod, and piston must rotate freely. Any "roughness," "tight spots," or "metallic noises" must be corrected before engine is run or serious damage may result.

10. Install cylinder head with a new head gasket. Torque head nuts in a crisscross pattern to 10 ft.-lb. (1.4 mkg) then torque as specified in Table 1.

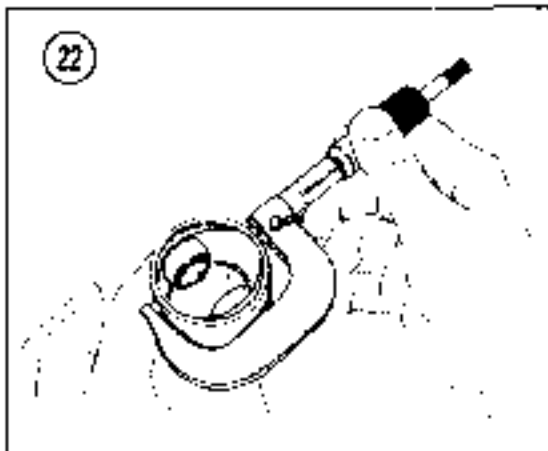
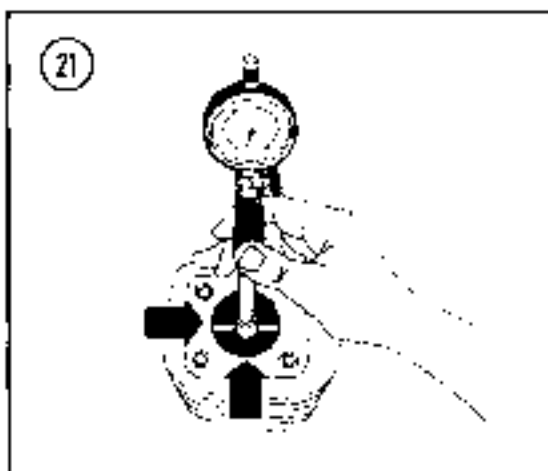

11. Install fan and magneto assembly.
12. Install external components on engine and install engine.

Crankshaft Assembly Removal/Installation

Crankshaft assembly, removal, inspection, service and repair, including crankcase bearing and seal replacement, should be referred to an authorized dealer or competent machine shop. They are equipped with the necessary special tools and expertise to perform the work.

COMPONENT INSPECTION

Some of the following inspection procedures require the use of micrometers and dial indicators for precise wear analysis. If such precision tools are not available, refer inspection

procedures to an authorized dealer or competent machine shop. Refer to Table 2 or 3 (end of chapter) for engine component dimensions and wear tolerances.

Cooling Fan and Belt

1. Inspect fan (Figure 20) for cracked, broken, or damaged fins. Dress nicks or dents with a file. If fins are cracked or broken, fan must be replaced.
2. Inspect fan bearings for wear or looseness. Replace if necessary.
3. Inspect fan belt and replace if frayed, stretched, or deteriorated.

Cylinder Taper and Out-of-Round

1. To check for cylinder taper perform the following:
 - a. Refer to Figure 21 and measure cylinder diameter $\frac{1}{4}$ in. (16mm) from top of cylinder down to just below intake port.
 - b. On rotary valve models, measure just below auxiliary transfer port, facing exhaust port.
 - c. If cylinder taper exceeds 0.003 in. (0.08mm) rebore and hone or replace the cylinder.
2. To check cylinder for out-of-round measure cylinder $\frac{1}{2}$ - $\frac{3}{4}$ in. (13-16mm) from top of cylinder. If cylinder out-of-round exceeds 0.002 in. (0.05mm) rebore and hone or replace the cylinder.

Piston-to-Cylinder Clearance

1. With a micrometer measure piston skirt at right angles to piston pin $\frac{3}{8}$ in. (8mm) from bottom of piston (Figure 22).
2. Measure cylinder bore $\frac{1}{2}$ - $\frac{3}{4}$ in. (13-16mm) below top of cylinder (Figure 21).
3. Subtract the piston measurement from the cylinder measurement to obtain piston-to-cylinder clearance. If clearance exceeds wear limit specified in Table 2 or 3 piston must be replaced. It may be necessary to hone cylinder to the next oversize.

Piston-to-Cylinder Clearance (Quick Method)

With the cylinder upside down on a workbench install the piston (without rings) into the cylinder bore. Refer to **Figure 23** and insert the thickest possible feeler gauge between the piston and cylinder wall on the intake side. If a feeler gauge larger than wear limit specified in **Table 3** can be inserted between piston and cylinder bore, a new piston or rebore is necessary.

Honing Cylinder Bore

If cylinder is within wear tolerance, but lightly scored, hone by running a fine stone cylinder hone lightly in cylinder (**Figure 24**).

Clean cylinder thoroughly with detergent and water to remove all particles.

Cylinder Head

1. Carefully scrape carbon from cylinder head and exhaust ports of cylinders. Use a soft metal (nonferrous) scraper to avoid damage. A wooden spatula works well for cleaning exhaust ports.
2. Use a spark plug tap (14mm or 18mm) to clean carbon from spark plug threads in cylinder head, if required.

Crankcase

1. Inspect crankcase sealing surfaces (**Figure 25**) for deep scratches, scoring, or pitting.
2. Inspect bearing and oil seal retaining inserts for wear, scoring, or conditions that could cause leaks.
3. Replace crankcase halves if damaged. Crankcase halves are available only in a matched set — not individually.

Piston Ring End Gap

Slide piston ring into cylinder between transfer port and intake port. On rotary valve engines, position ring just below the transfer ports. Use piston ring to slide ring into position to ensure that ring is perfectly square inside bore. Measure ring end gap with feeler gauge as shown in **Figure 26**. Refer to **Table 2** or **3** and replace ring if end gap is excessive.

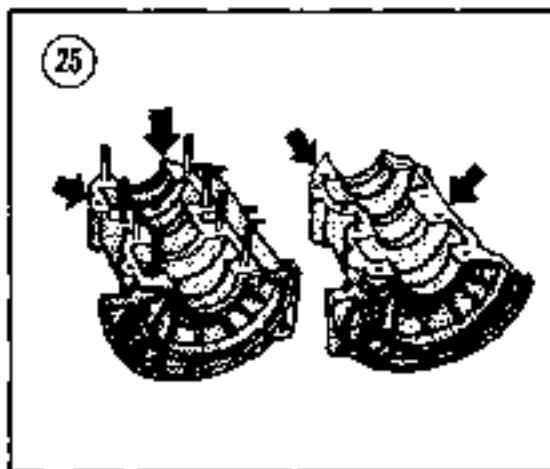
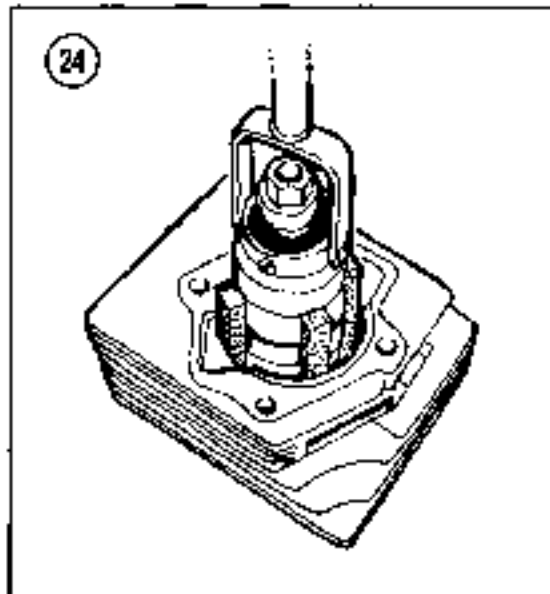
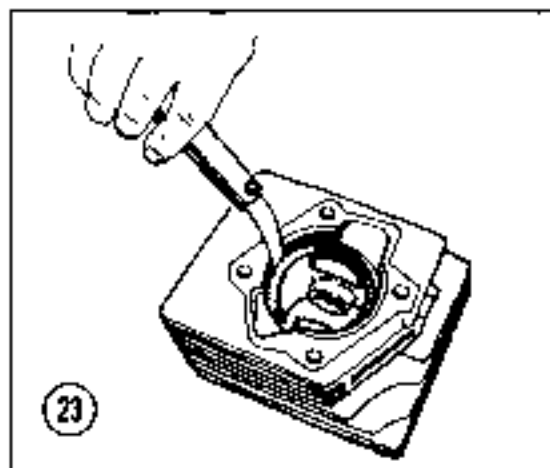

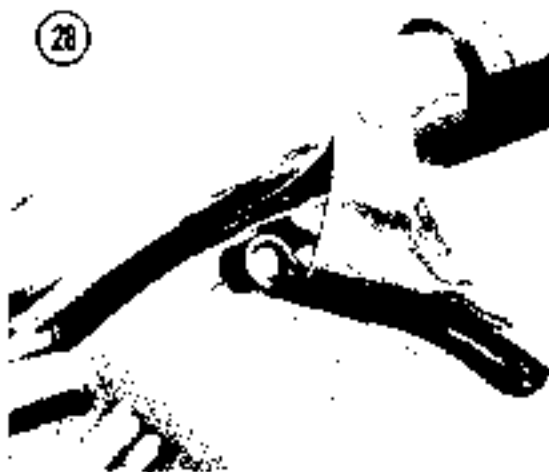
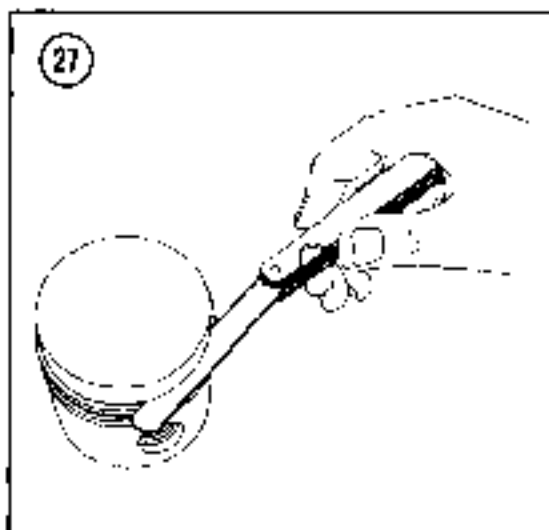
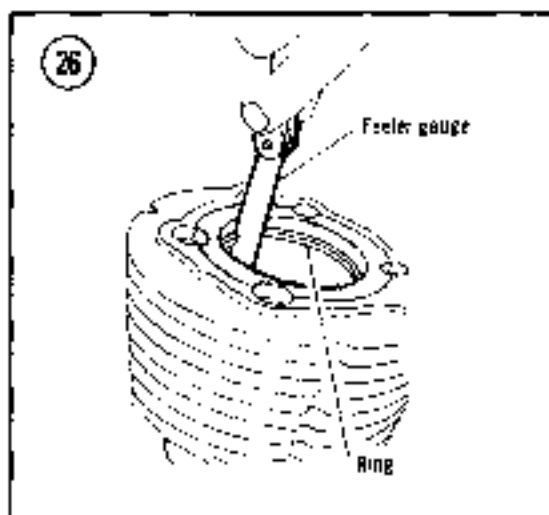

Piston Ring Groove Clearance

With a feeler gauge check side clearance of rings in grooves (Figure 27). If clearance is greater than 0.008 in. (0.20mm), replace the piston and rings.

Crankshaft and Connecting Rod

Refer all clearance inspection, service, and repair work on crankshaft assembly to an authorized dealer or competent machine shop.

1. Inspect threads on each end of crankshaft. Inspect keyway on flywheel end and taper on each end of crankshaft for scoring or wear.
2. Inspect ball bearings for wear, free movement, and security.
3. Inspect seals for wear or damage.

TWIN CYLINDER ENGINES

The basic procedures for removal, disassembly, and repair of twin cylinder engines are the same. Specific differences will be noted in the procedures where necessary.

Engine Removal/Installation (Mid-Engine Models)

1. Remove pulley guard and drive belt. Remove console on Olympique models.
2. Disconnect brake and throttle cables and housings from handlebar and brake lever (Figure 28).
3. Disconnect kill button from handlebar on models so equipped.
4. Disconnect all electrical connections from engine. Tag all wire locations to aid installation.
5. Remove air silencer on models so equipped (Figure 29) and disconnect fuel lines from carburetor. On TNT models, disconnect springs securing muffler to engine.
6. Disconnect steering column retaining bracket from upper column (Figure 30).
7. Remove nuts securing engine mount to frame (Figure 31).
8. Lift engine from machine.

NOTE: On TNT models, tilt upper column toward seat and lean engine to the

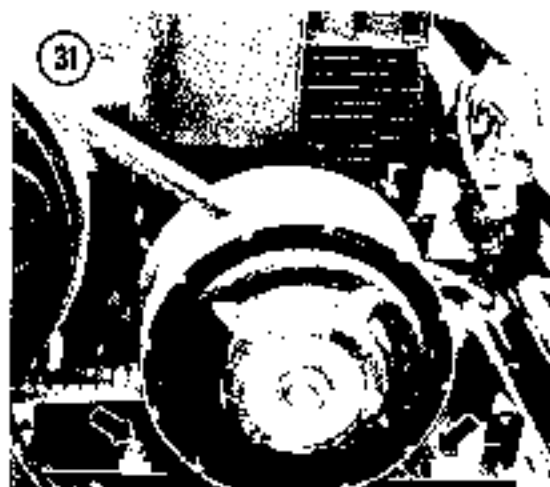
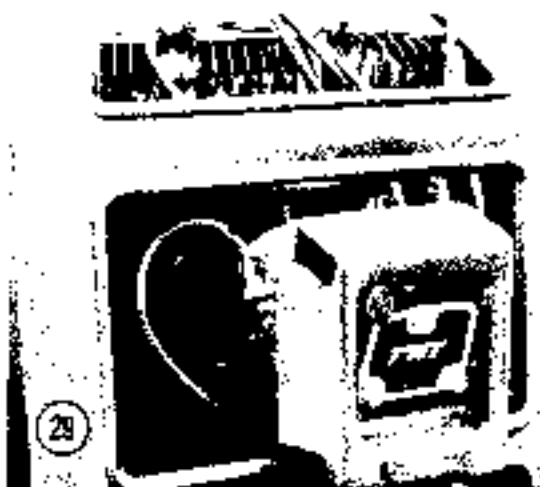

rear to disengage exhaust manifold from muffer. Remove engine from left side.

9. Installation is the reverse of these steps. Keep the following points in mind:

- a. Torque engine mounting nuts to 22-25 ft.-lb. (3.0-3.5 mkg).
- b. Adjust brake as outlined in Chapter Two.
- c. Perform *Pulley Alignment* as outlined in Chapter Seven.

Engine Removal/Installation (Front Engine Models)

1. Remove pulley guard and drive belt.
2. Remove muffer and air silencer (Figures 32 and 33).

3. On liquid cooled models perform the following:

- a. Remove coolant tank pressure cap and disconnect bypass hose from cylinder head fitting (Figure 34). Route bypass hose into a clean container if coolant is to be retained. Block off bypass fitting and keep bypass hose as low as possible to drain the system.
 - b. Cover filler neck with your hand and blow through tank vent tube to completely drain the system (Figure 35).
 - c. Disconnect coolant hoses from the engine.
4. If necessary disconnect the cab retaining cable.
 5. Disconnect primer and impulse lines.

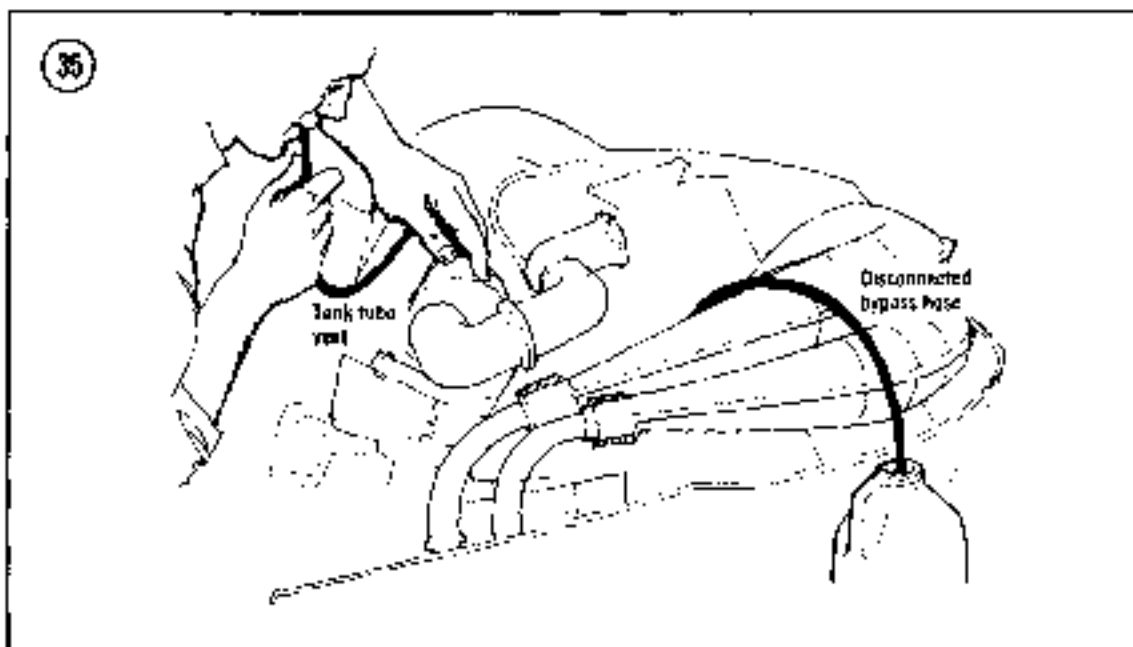
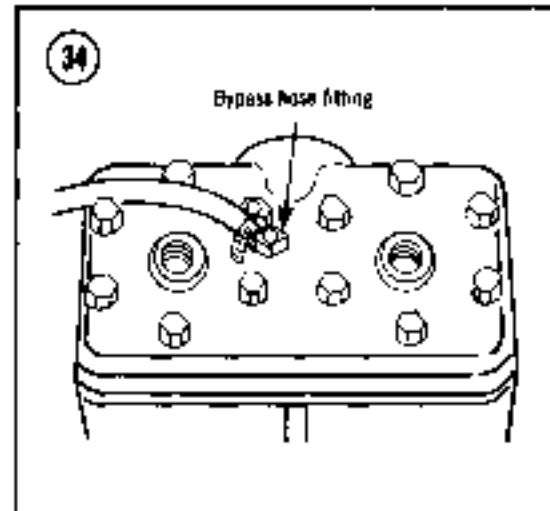

6. If carburetor is to be removed with the engine, disconnect the throttle cable and fuel lines.

7. If carburetor is to be removed, perform the following:

- a. Remove nuts securing carburetor and slide carburetor off mounting studs (Figure 36).
- b. With fuel lines and cables still attached, swing carburetor out of the way (Figure 37).

8. On rotary valve models, disconnect oil line from bottom of oil reservoir and drain oil from reservoir and crankcase. Disconnect upper oil vent line.

NOTE: On models equipped with 444 liquid cooled engines, it is not necessary to disconnect oil tank lines prior to engine removal. Tank can be drained and removed after engine removal.

9. Remove recoil starter.

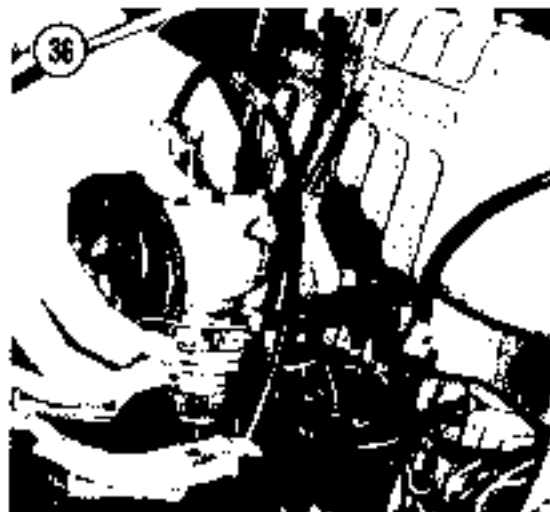

10. Disconnect all electrical connections (see Figure 38). Tag wire locations to aid installation. On models equipped with electric starter, disconnect ground cable (-) from battery before disconnecting other wires (Figure 39).

11. If necessary, remove drive pulley as outlined in Chapter Seven.

12. Remove nuts securing engine mount to machine (Figure 40) and lift out engine.

13. Installation is the reverse of these steps. Keep the following points in mind:

- Torque engine mounting nuts to 22-25 ft.-lb. (3.0-3.5 mkg)
- Perform *Pulley Alignment* as outlined in Chapter Seven.
- On rotary valve models top off oil reservoir as outlined in Chapter Two.



Flywheel and Magneto Removal/Installation

The following procedure requires the use of special tools to remove the flywheel and magneto assembly. If special tools or locally fabricated equivalents are not available, refer task to an authorized dealer.

- Remove engine.
- Remove muffler and recoil starter if not previously removed.
- Remove nuts securing fan belt pulley/starter pulley to magneto ring plate. Remove belt and pulley (Figure 41).

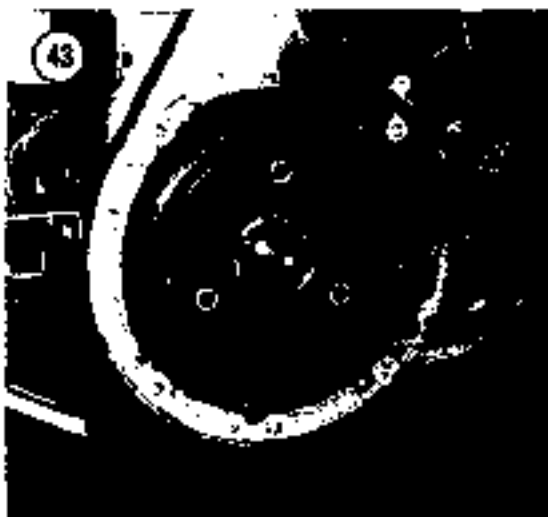
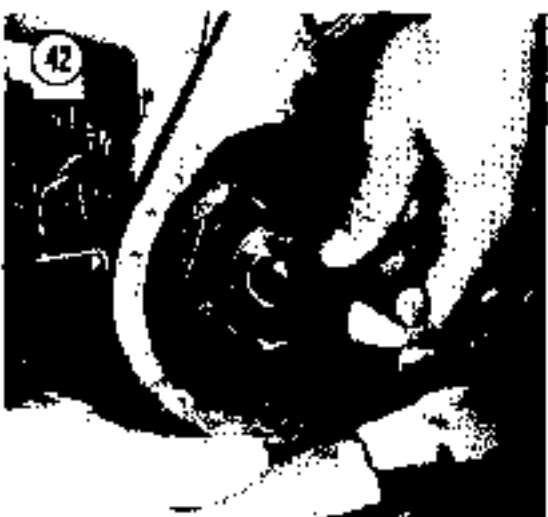

4. Using a hammer and a small punch, straighten locking tab behind magneto unit (Figure 42).

5. Install special crankshaft holding tool to magneto ring plate using nuts and washers from fan belt/starter pulley (Figure 43).

If special crankshaft holding tool is not available, perform the following:

- a. Insert a length of rope such as recoil starter rope into the spark plug hole.
- b. Slowly rotate crankshaft counterclockwise until the piston bears against the rope.

On 354 and 503 engines the crankshaft can be held by using the crankshaft locking bolt (Figure 44). Locate magneto side piston at Top and install bolt into hole in crankshaft. On 503 models remove the aluminum spacer from under the bolt. Do not overtighten the bolt as it does not hold by pressure against the crankshaft.

NOTE: On electric start engines that are being disassembled for major engine work, use special puller and remove starter gear complete with shims and spacers.

Remove nuts securing starter motor and bracket to engine and remove starter and bracket.

6. Remove magneto nut.
7. Install flywheel puller (Figure 45) and

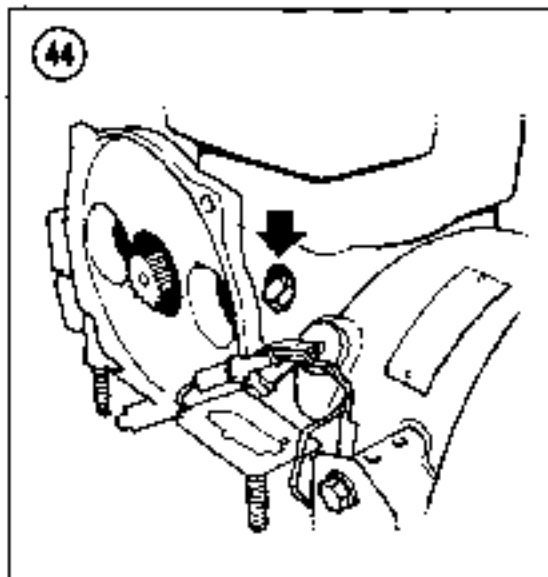

remove magneto housing (Figure 46). Remove puller and holding tool from magneto ring plate.

8. If desired, on models so equipped, remove flat end screw and remove centrifugal advance weight and spring from magneto ring plate (Figure 47).

NOTE: If further disassembly is desired, remove 4 Allen screws and remove ring plate from magneto ring.

CAUTION

Always place magneto ring on a clean cloth or magneto may attract dirt and/or metal particles that can affect magneto efficiency.

9. On models equipped with one-piece cooling shroud, perform the following:

- a. Remove bolts and washers securing shroud to cylinder head spacer nut.
- b. Remove 3 screws securing fan housing to shroud and remove shroud.

10. On models equipped with 2-piece cooling shroud, perform the following:

- a. Remove bolts securing exhaust side shroud.
- b. Remove 2 screws securing fan housing to exhaust side shroud (Figure 48).

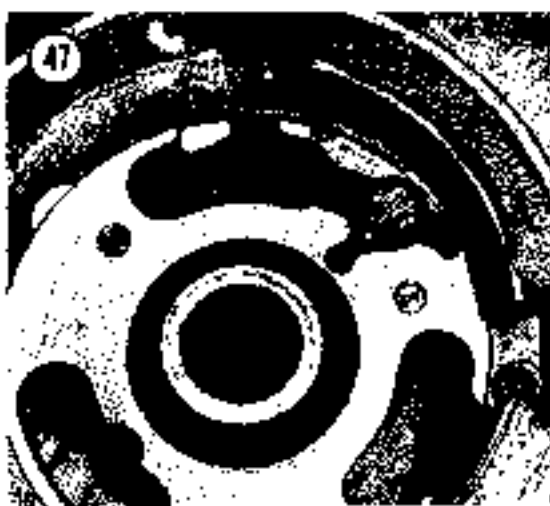
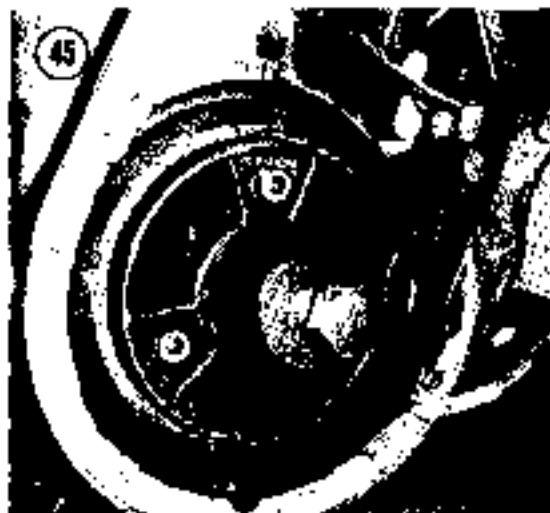

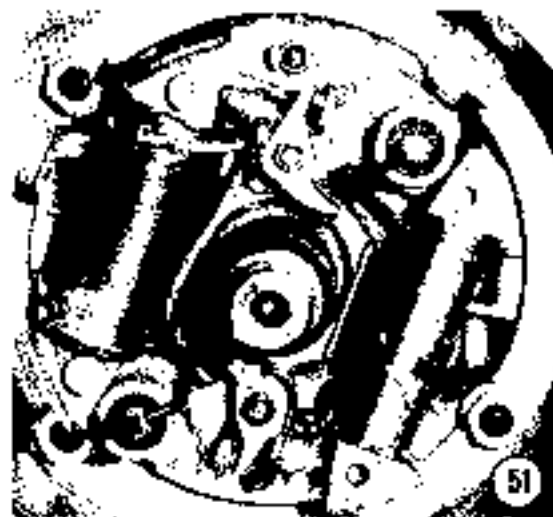
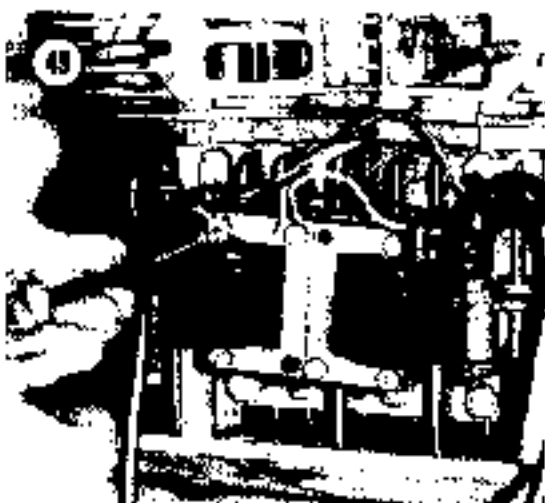

c. Remove nut securing shroud stud and remove stud and shroud.

11. On models equipped with engine console, remove Allen screws securing console to cooling shroud and remove console.

12. Remove throttle cable bracket from shroud on models so equipped.

13. Disconnect wiring from ignition coils and remove coils (Figure 49). Tag wires to aid installation.

14. Remove coil bracket from crankcase on models equipped with one-piece cooling shroud (Figure 50).

15. On models equipped with 2-piece shroud, remove screws securing fan housing to intake side shroud and complete shroud removal.

16. Remove 4 nuts and washers securing fan housing (Figure 51) to engine and remove housing. If repair of fan housing is necessary, refer to *Cooling Fan Disassembly*.

17. Press in and hold magneto cam toward armature plate and tap out crankshaft Woodruff key with a hammer and small punch. Remove cam with spring and washer from crankshaft (Figure 52).

18. Remove 2 nuts or Allen screws securing armature plate and remove plate (Figure 53).

19. Installation is the reverse of these steps. Keep the following points in mind:

- a. Be sure armature plate wiring is routed through notch in fan housing and shroud

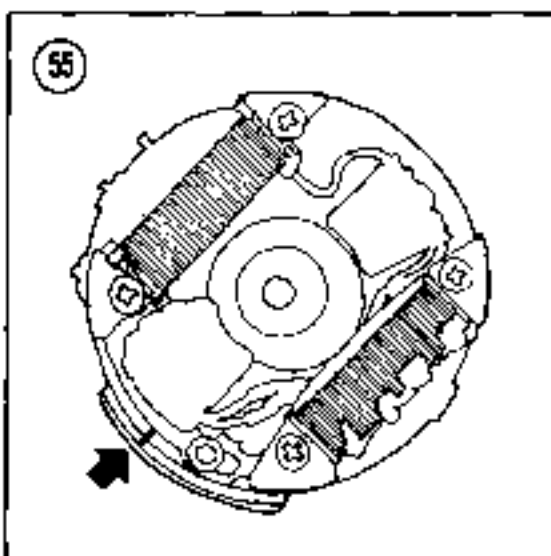
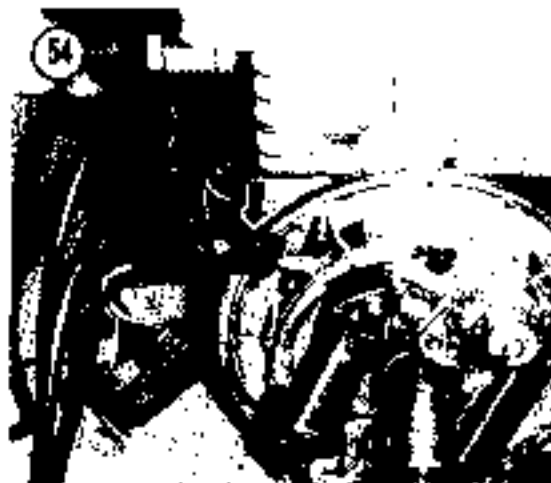
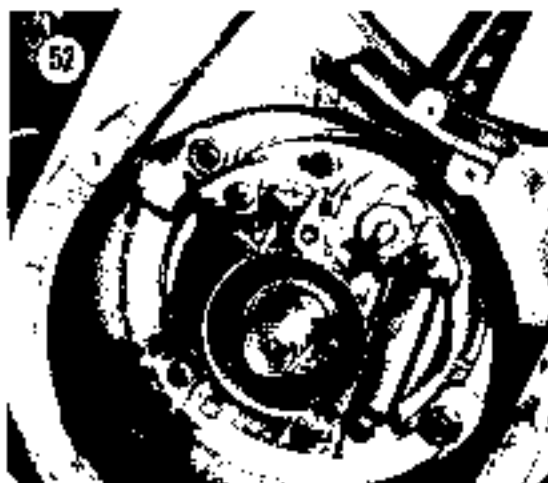

and rubber grommet) is in proper position (Figure 54).

- b. Lightly grease inner channel of cam with low temperature grease.
- c. Lightly grease spring seating of magneto ring plate with low temperature grease.
- d. Rotate crankshaft until Woodruff key is up and rotate cam clockwise until notch is 45° from key.
- e. When installing magneto plate, align crankcase and armature plate marks (Figure 55) for preliminary timing adjustment. For 354 engines, position armature plate on crankcase with retaining screws in the middle of plate slots as shown in Figure 56.
- f. Check magneto coil air gap (distance between end of coil and magnet) with a feeler gauge as shown in Figure 57. For 354 engines, check gap as shown in Figure 58. Refer to Table 4 for air gap specifications.
- g. Torque the magneto nut as specified in Table 1.
- h. On models equipped with one-piece cooling shroud, install ignition coil bracket before mounting coils.
- i. On 1978 and later models equipped with 440 engines, install fan shroud bolts as shown in Figure 59.

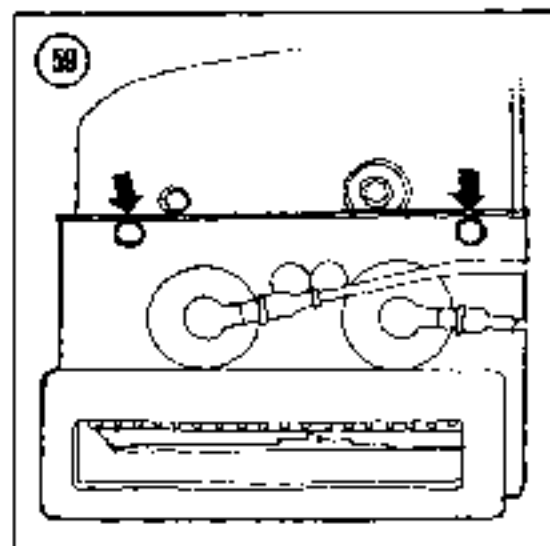
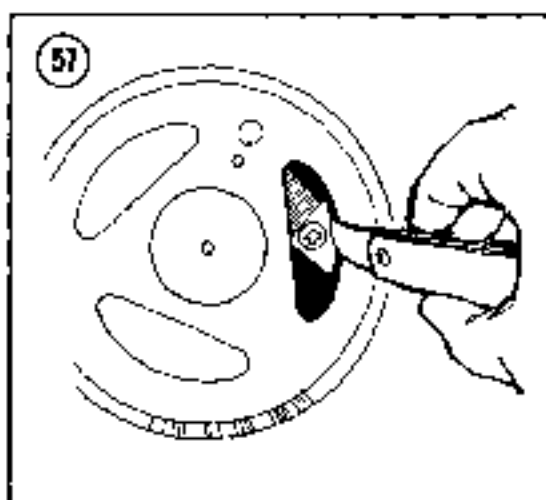
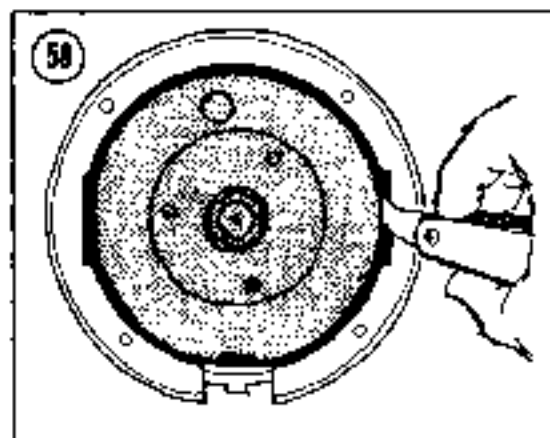
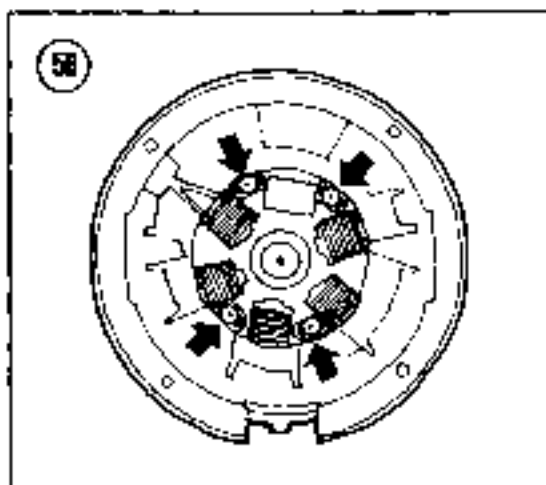

Table 4 MAGNETO AIR GAP SPECIFICATIONS

Engine	Air Gap
247 3U2 singles	0.010-0.015 in. (0.25-0.38mm)
354 twin	0.040-0.063 in. (1.0-1.6mm)
All other twins	0.012-0.018 in. (0.30-0.45mm)

- j. Perform *Fan Belt Adjustment*.
 k. Perform ignition timing as outlined in Chapter Two.

Cylinder Head, Cylinder, Piston, and Ring Removal

Refer to Figures 60 and 61 for typical examples of air and liquid cooled top end components.

1. Remove engine.
2. Remove flywheel, magneto assembly, and fan housing with cooling shrouds.
3. Remove intake manifold, gaskets, and flanges (Figure 62). Remove air deflector if so equipped (Figure 63).
4. Remove exhaust manifolds (Figure 64). Unscrew exhaust sockets from cylinders on engines so equipped (Figure 65).

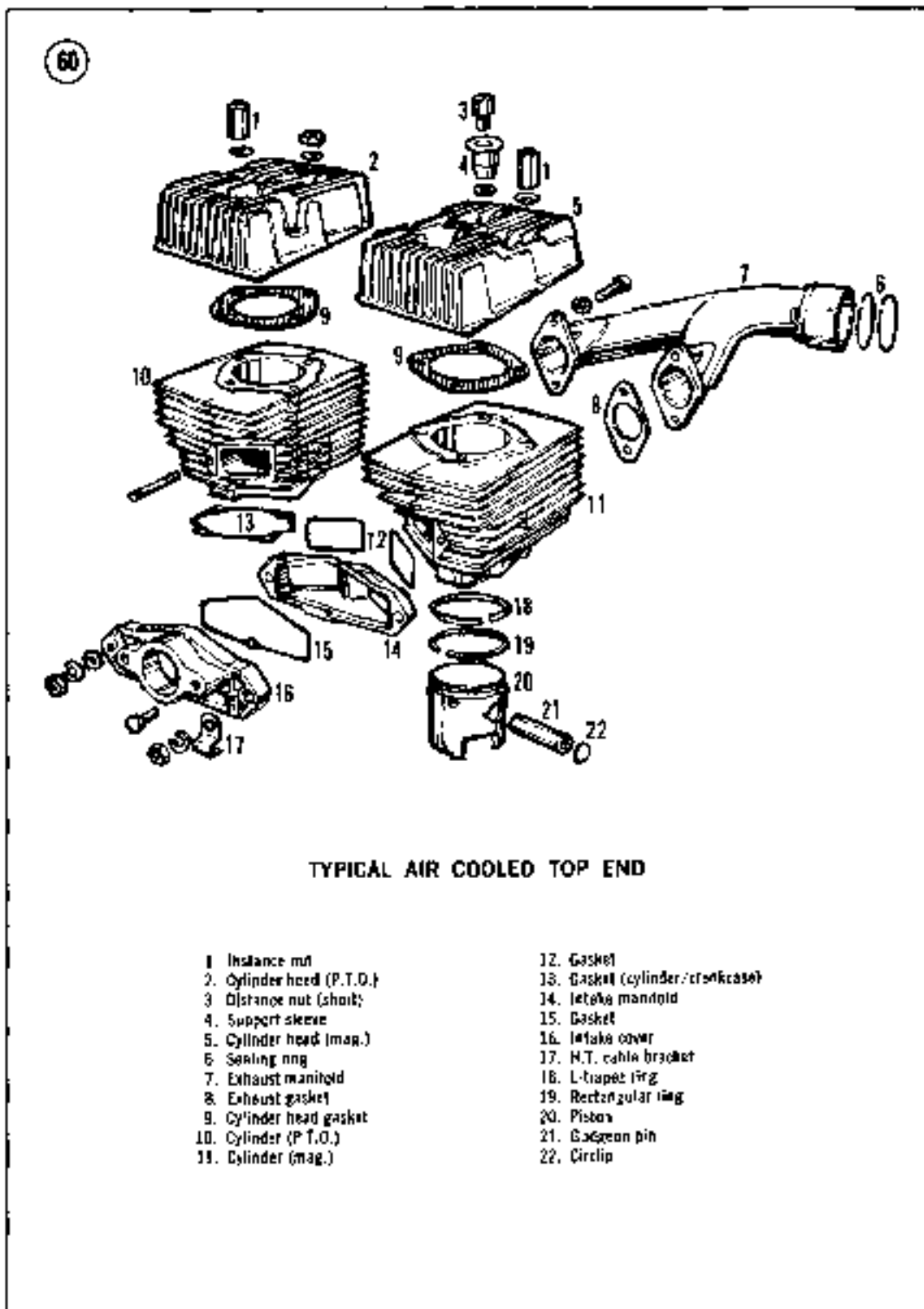

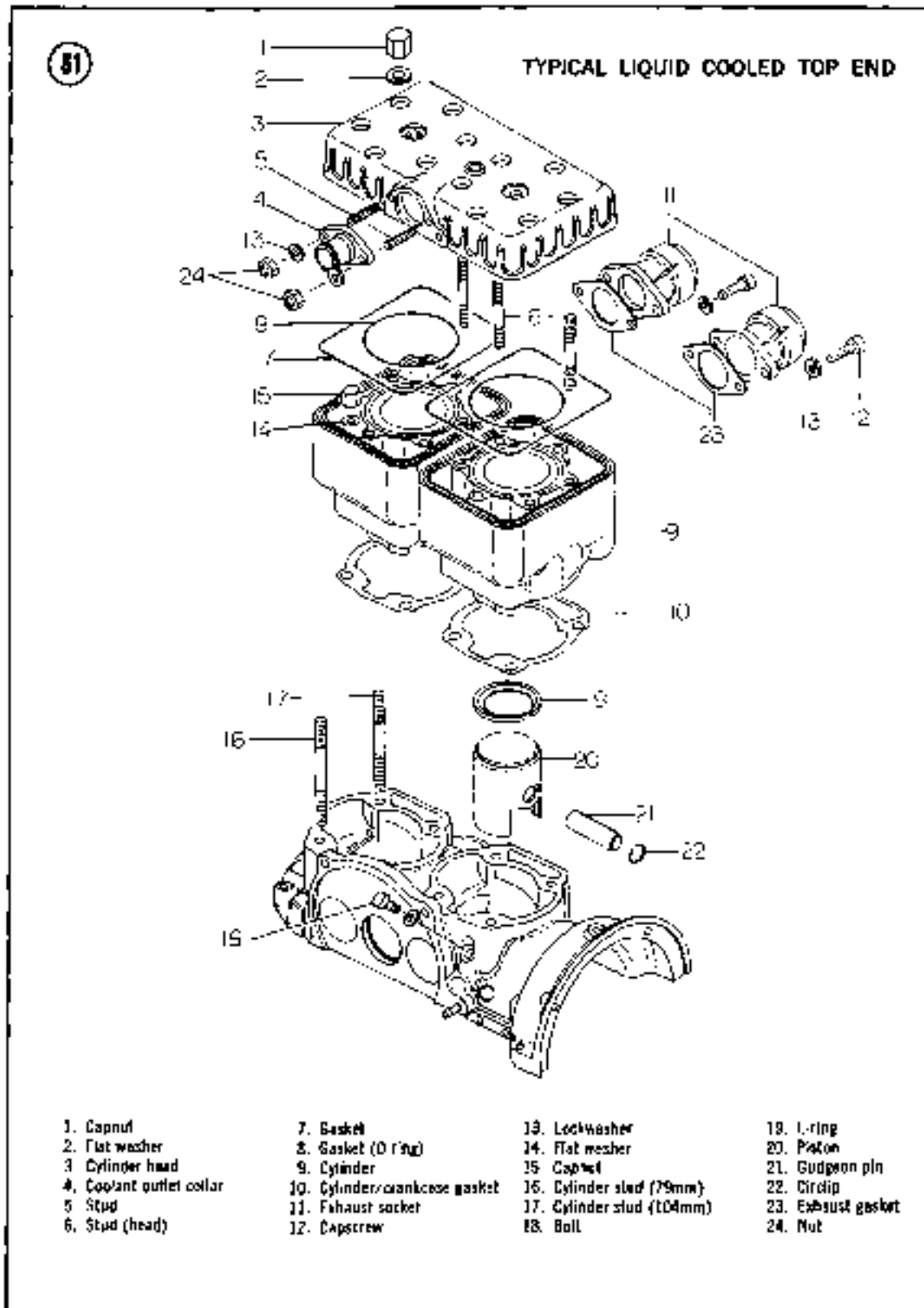

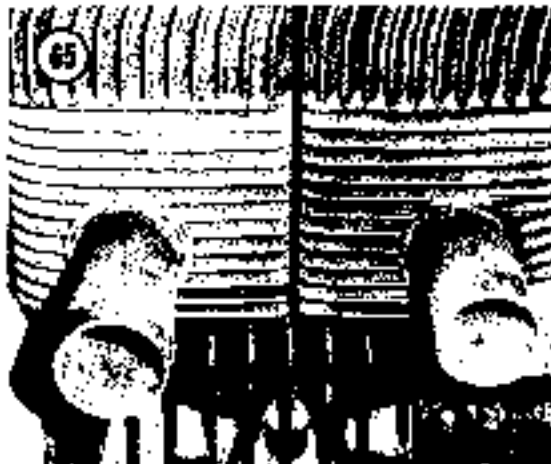

NOTE: Cylinder installation requires that cylinders be properly aligned before head bolts are tightened. This is accomplished by first installing the intake and/or exhaust manifolds. On models with exhaust sockets and/or twin carburetors, proper alignment cannot be achieved without the use of an alignment tool. Such a tool can easily be locally fabricated from strap or angle iron and drilled to exactly match the manifold studs (Figure 66). If it is necessary to locally fabricate such a tool, do so before head bolts are loosened in order for the tool to exactly represent correct cylinder alignment.

5. Gradually loosen in a crisscross pattern, then remove nuts securing cylinder heads

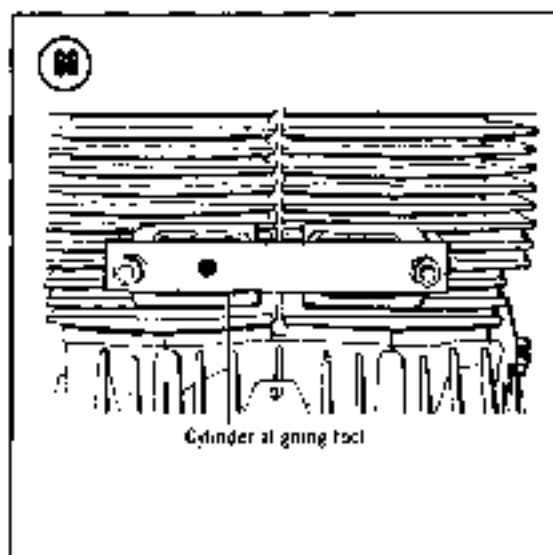



(Figure 67). Note fixation of long nuts to aid installation. To aid head removal, gently tap head with a rubber mallet. Remove heads and discard old gaskets (Figure 68).

6. Gently slide cylinders up over pistons (Figure 69).

7. Note mark on each piston indicating exhaust side of engine (Figure 70). If no marks are visible, inscribe them accordingly. Also ensure that pistons are marked "1" and "2" since they are not interchangeable, if they are not to be replaced with new ones.

NOTE: If rings are going to be changed, but not pistons, rings may now be removed. However, if pistons are going

to be removed, leave oil rings on pistons to protect ring grooves until new rings are to be installed.

8. Using a ring expander tool or your thumbs on each end of piston ring, gently expand ring and slide up and off piston (Figure 71).

9. Be sure pistons are appropriately marked. Remove circlips from each end of piston pins (Figure 72).

NOTE: Stuff clean rags around connecting rods in crankcase to help prevent circlips from dropping into crank case.

Using a piston pin removal tool or an appropriately sized wooden dowel, gently remove pins from piston and connecting rod (Figure 73).



CAUTION

Exercise care when removing pins to avoid damaging connecting rod needle bearings. If a wooden dowel is used to drive out piston pins, ensure that piston is properly supported so lateral shock is not transmitted to lower connecting rod bearing, otherwise rod and/or bearing damage may occur.

Remove needle bearings from connecting rods (Figure 74).

10. Refer to *Component Inspection* and inspect cylinders, pistons, pins, and rings.

Cylinder Head, Cylinder, Piston and Ring Installation

1. Lubricate piston pin needle bearings with oil and insert bearings into connecting rods.
2. Slide piston over connecting rod. Be sure that the mark or letters *cos* face exhaust side of engine (Figure 70).
3. Using piston pin installation tool or appropriately sized wooden dowel, install piston pins through piston and rod ends (Figure 73).

CAUTION

Exercise care when installing pins to avoid damage to connecting rod needle bearings. If a wooden dowel is used to drive in piston pins, ensure that piston is properly supported so lateral shock is not transmitted to lower connecting rod bearing; otherwise rod and/or bearing damage may occur.

4. Secure piston pins to pistons with circlips. When circlip is properly installed in groove,



rotate circlip so gap in clip is not directly on notch break of piston (Figure 75).

NOTE. *Stuff clean rags around connecting rods in crankcase to help prevent circlip from dropping into crankcase.*

CAUTION

If possible, use new circlips to secure piston pins. If old circlips are used, they must snap securely into grooves in pistons. A weak circlip could become disengaged during engine operation and cause severe engine damage.

5. Using a ring expander tool, or your thumbs on each end of piston ring, gently expand ring



and slide over piston into ring groove (Figure 74). Install ring in bottom groove first. Be sure that ring groove clearance is within tolerance as outlined in *Component Inspection*.

NOTE: Be sure ring end "V" is properly positioned in ring groove.

6. Install new cylinder base gaskets.
7. Thoroughly lubricate pistons, rings, and cylinder bores with engine oil.
8. Install cylinder over studs. Ensure that exhaust ports face exhaust side of engine. Compress rings with your fingers and slide cylinders down over piston (Figure 76).

CAUTION

Cylinders must be properly aligned before head nuts are tightened or serious engine damage may result.

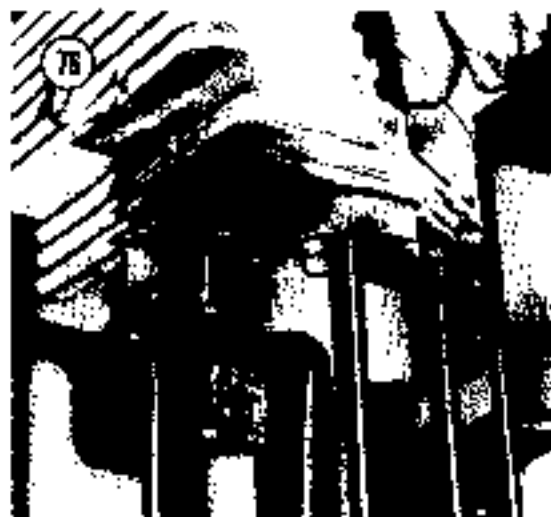

9. On liquid-cooled models, keep the following points in mind:
 - a. Cylinder stud length must be correct or the cap nuts will not tighten completely. Refer to Figure 77 for 354 engines and Figure 78 for 444 engines. If stud length is excessive, washers must be added under cap nuts to prevent nuts from bottoming on studs.
 - b. Longer threaded portion of studs should be screwed into crankcase.
 - c. On 354 engines, temporarily install cylinder head to align both cylinders. Torque cylinder nuts in a crisscross pattern to 12 ft. lb. (1.6 mkg).

10. Install intake and exhaust manifolds with new gaskets on cylinders. On models with twin carburetors or exhaust sockets, install alignment tool as described in removal procedure (Figure 66). Tighten nuts securing manifolds and/or alignment tool.

11. Install cylinder heads with new head gaskets. On liquid-cooled models, apply silicone sealant around studs and washer seats before installing head cap nuts. Install head nuts making sure long and short nuts are properly positioned (Figure 79).

12. On air-cooled models, tighten head nuts in a crisscross pattern, each head separately. Refer to Figure 80 for liquid-cooled models. Torque all nuts to 10 ft.-lb. (1.4 mkg) then to value specified in Table 1.

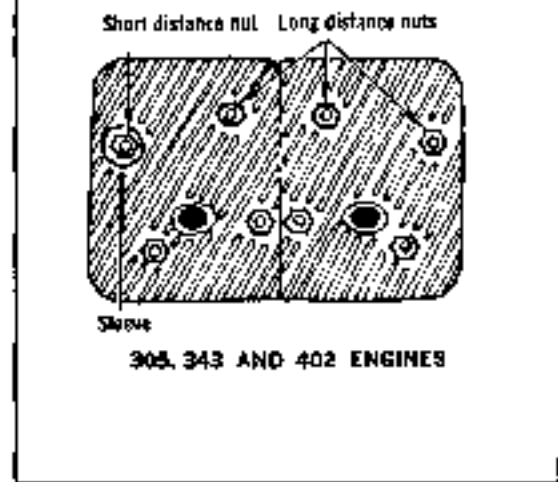
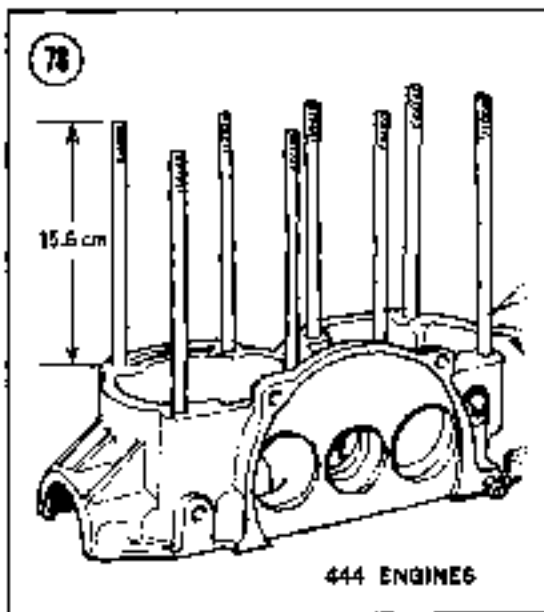
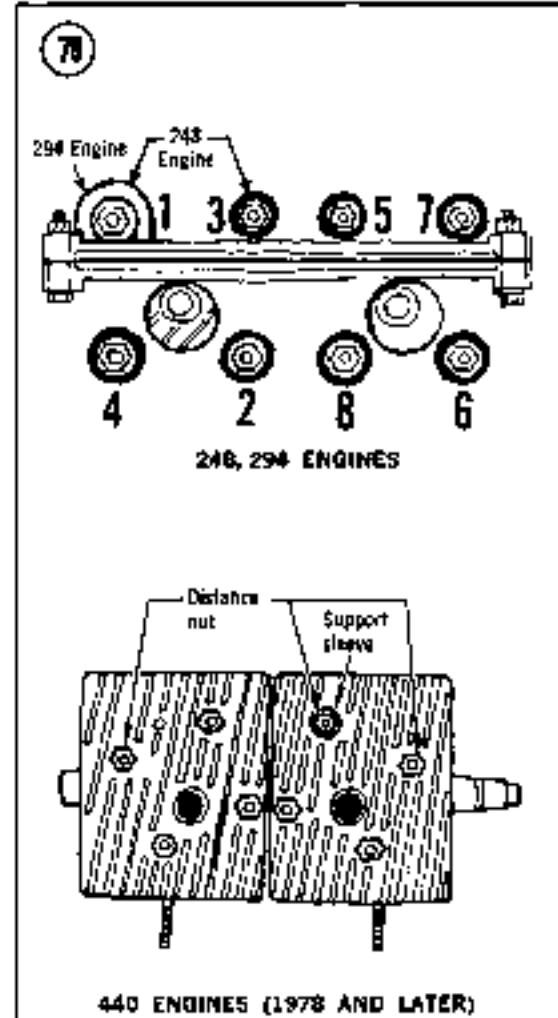
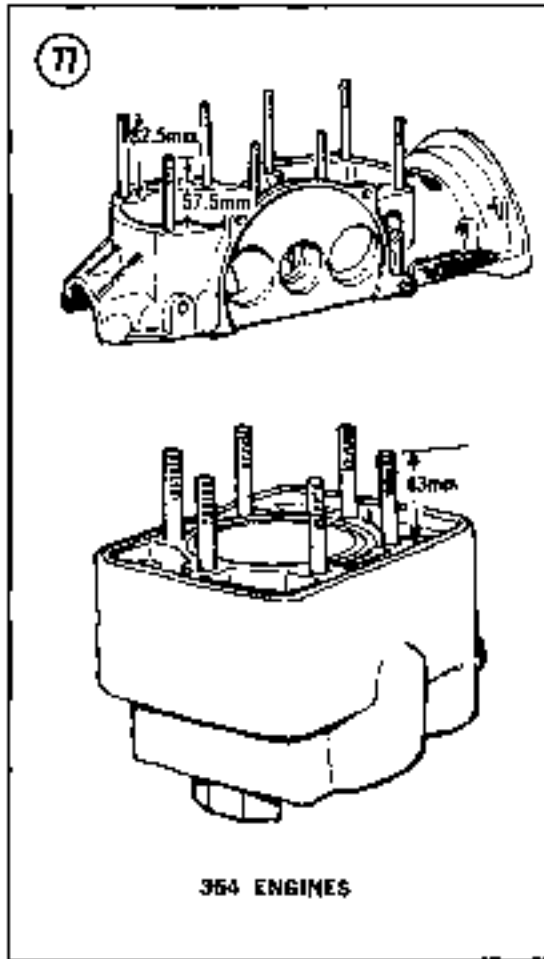

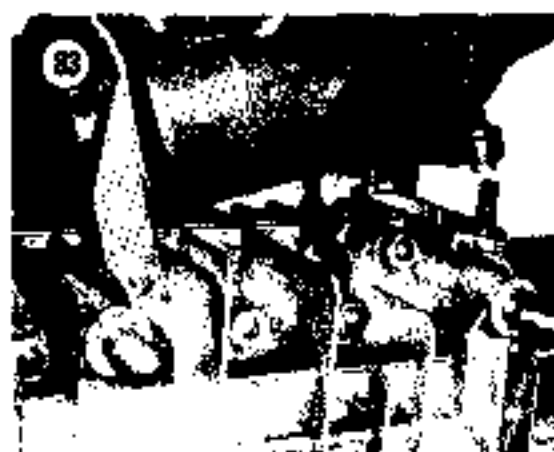
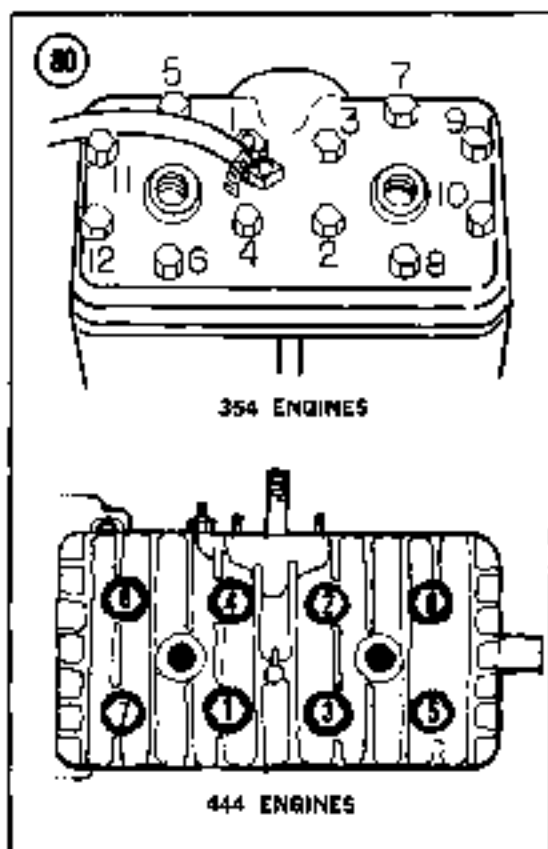

13. Install exhaust sockets or exhaust manifold. Shorter socket is installed on the pro (power take off) side of the engine.

14. Install intake manifold, flywheel, magneto assembly, and fan housing with cooling shrouds.

15. Install engine.

Crankshaft Assembly Removal

Refer to **Figure 81** for a typical crankshaft assembly.

1. Remove cylinder heads, cylinders and pistons.

2. On rotary valve models perform *Rotary Valve Removal*.

3. Remove engine mount from crankcase if not previously performed (**Figure 82**).

4. Remove electric starter on models so equipped (**Figure 83**).

5. Remove nuts securing crankcase halves together.

6. Tap upper crankcase half lightly with a soft mallet and separate crankcase halves (**Figure 84**).

CAUTION

Never attempt to pry crankcase halves apart with screwdriver or similar object or crankcase sealing surface will be damaged.

7. Gently lift up and remove crankcase assembly (**Figure 85**).

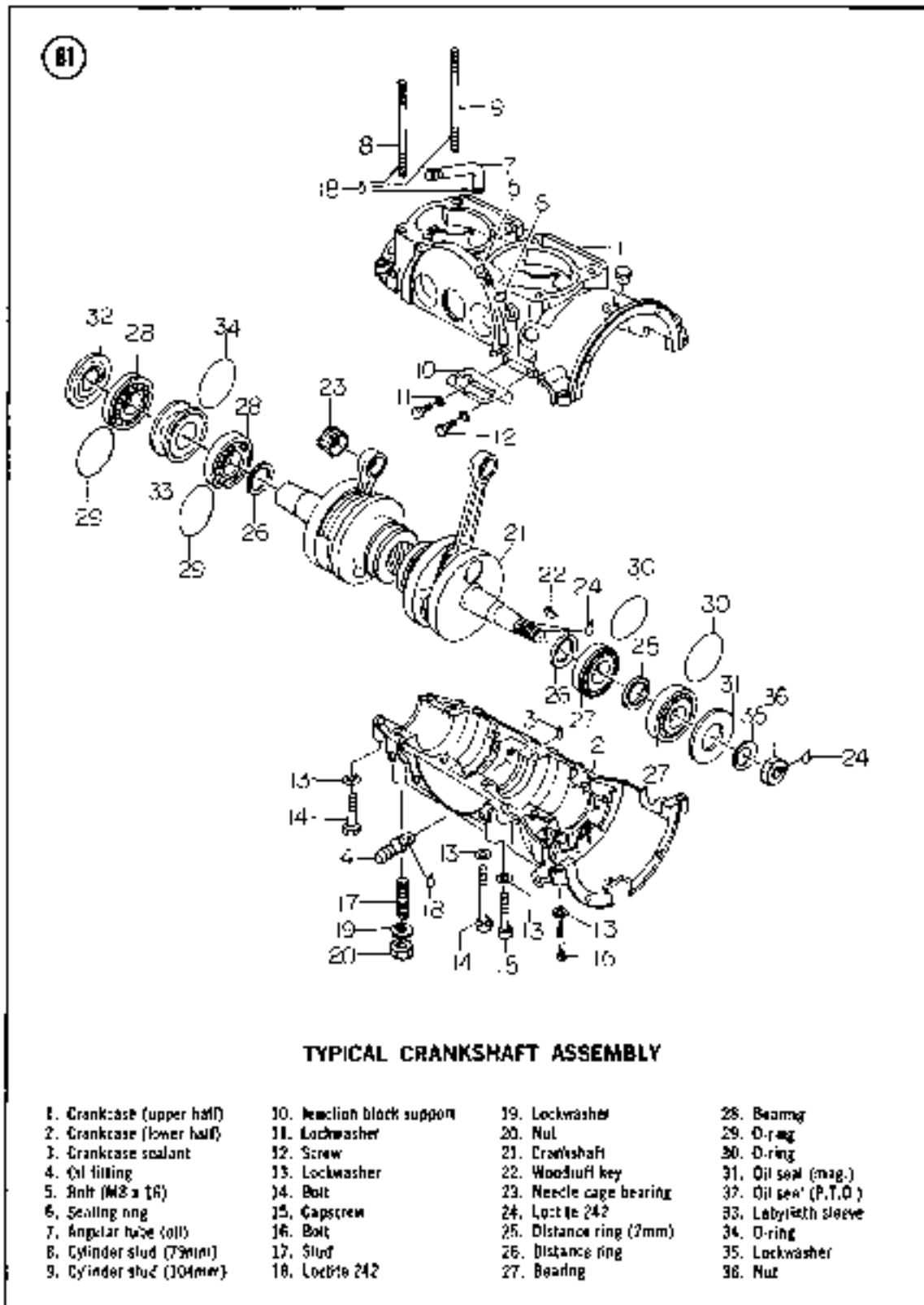

8. Perform crankshaft assembly and crankcase inspection as outlined in *Component Inspection*. Refer all crankcase assembly repair and service work to an authorized dealer or competent machine shop. They are equipped with the necessary special tools and expertise for the task.

Crankshaft Assembly Installation

1. Check the condition of O-rings on outer bearing races. The O-rings are necessary to keep the outer bearing races from turning in the crankcase. Replace O-rings if necessary.

NOTE. On 503 engines the O-rings are replaced by rubber buttons.

2. Install crankshaft assembly into lower crankcase half. Thoroughly lubricate crankshaft and bearings with engine oil.

CAUTION

If crankshaft and/or crankcase has been repaired or replaced, ensure that end play is properly set by an authorized dealer or machine shop. See Table 1.

3. Check that crankcase sealing surfaces are clean and not damaged. Apply an even coat of silicone rubber adhesive to sealing surfaces on both crankcase halves. Make sure no rubber adhesive runs into crankcase.

4. Install upper crankcase half. Check that the seals are correctly positioned and are not cocked down.

5. Install nuts, flat washers, and lockwashers and tighten evenly in sequence (Figure 86).



Torque nuts as specified in **Table 1**. Keep the following points in mind:

- On 245, 345, 346, 396, and 436 engines, spring washers are *not* installed on just 2 magneto side studs.
- On 248cc and 294cc engines, torque 2 smaller nuts on magneto side to 9 ft.-lb. (1.2 mkg).
- On 354 engines, torque 2 smaller bolts on magneto side to 10 ft.-lb. (1.3 mkg).

Rotary Valve Removal/Installation

Refer to **Figure 87** for a typical rotary valve assembly.

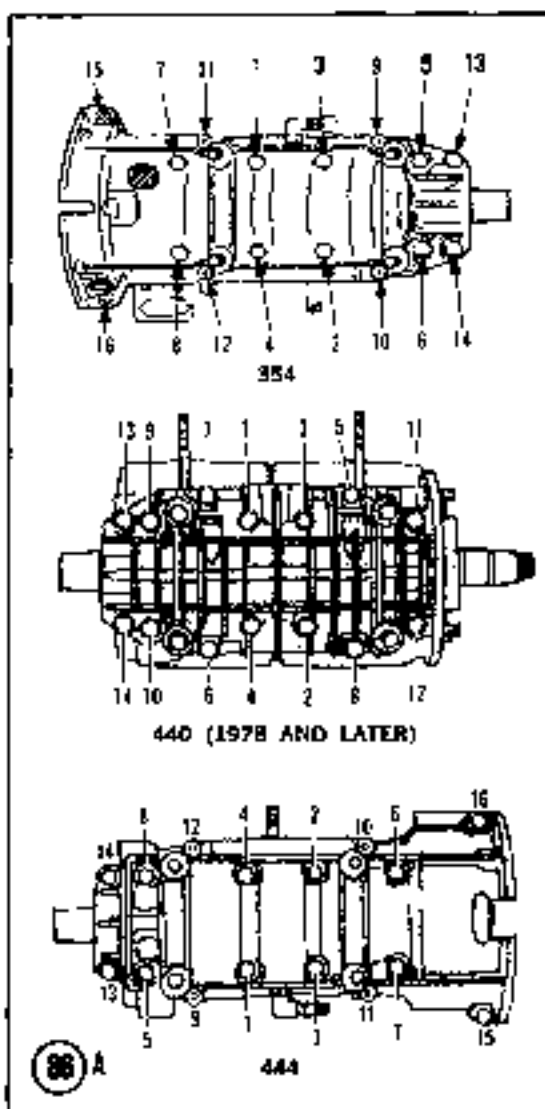

86 B

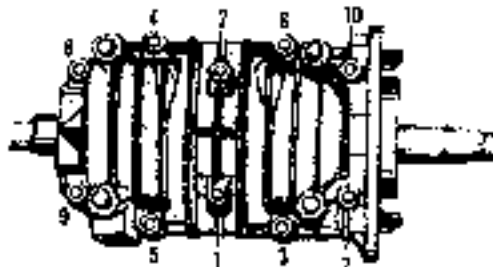

305, 338, 343, 401

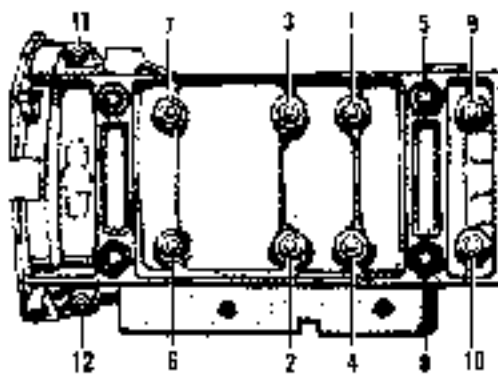

248, 254

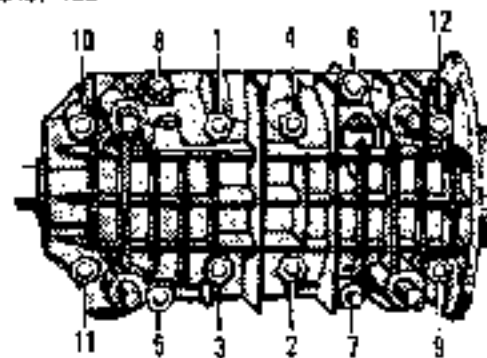

434, 446 (TO 1977)

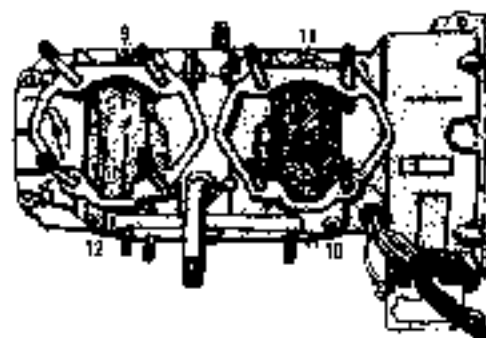
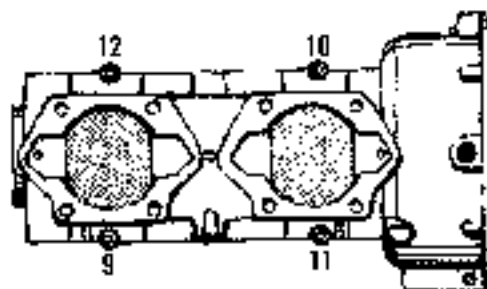
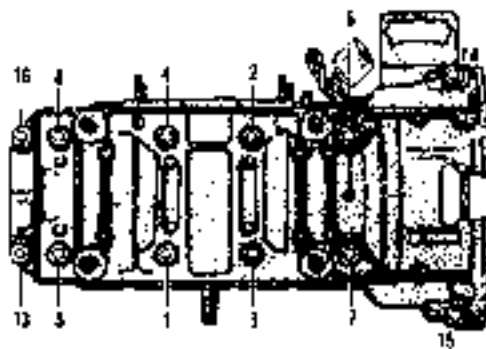

245, 345

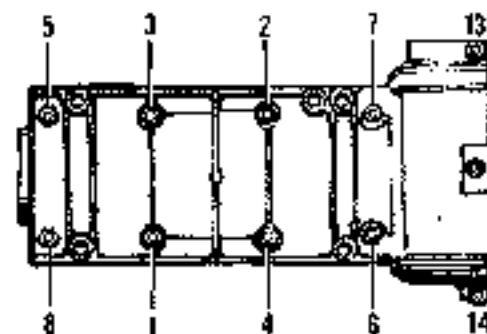

346, 356, 436

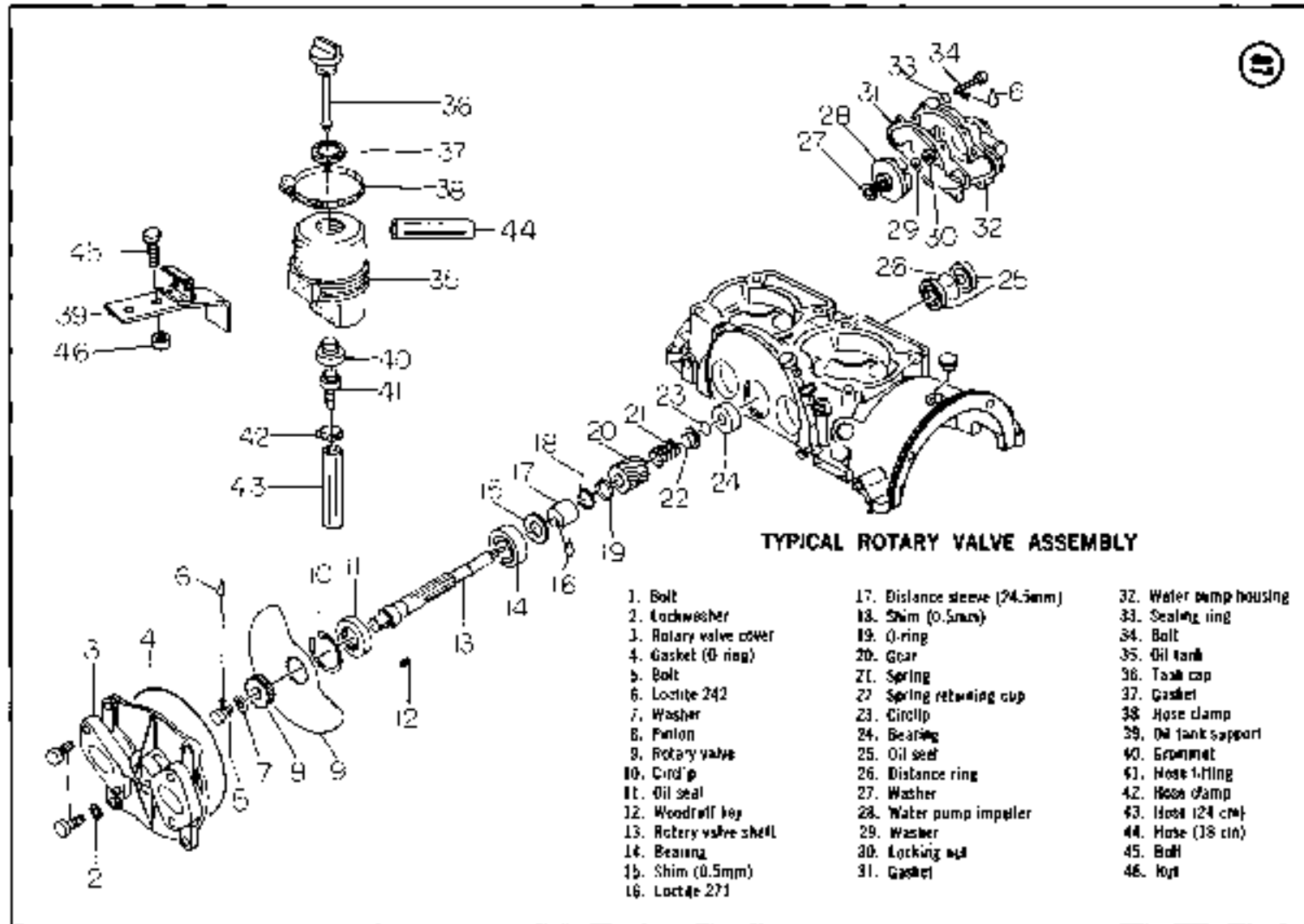

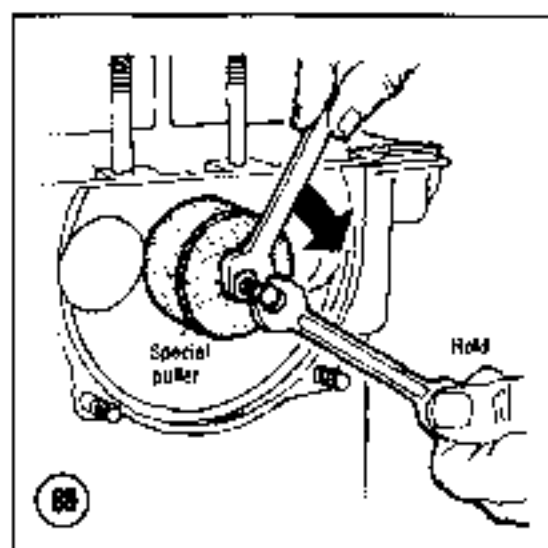
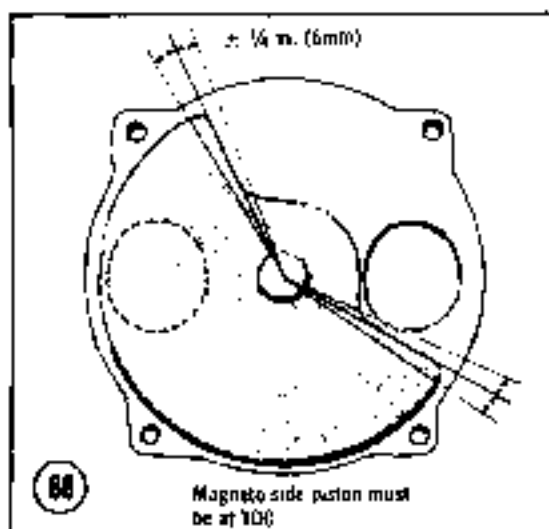

1. Remove carburetors and rotary valve cover. Note location of large O-ring gasket behind rotary valve cover.

2. Mark outside of valve disc with a felt tip pen to assist valve installation. Remove screw and washer retaining valve disc and remove disc.

3. To install valve disc, perform the following:

- Rotate magneto side piston to TDC (top dead center). Use dial indicator-type timing gauge as described in Chapter One.
- Position rotary valve on gear so edges align within $\frac{1}{8}$ in. (6mm) of timing marks on each side (Figure 88).

NOTE: If timing marks are not visible, perform Rotary Valve Timing.

- Rotary valve disc is asymmetrical. Position each side of valve disc on gear to determine position in which greater alignment accuracy can be achieved.

4. If rotary valve shaft assembly removal is desired, perform the following:

- Remove circlip securing shaft assembly (10, Figure 87).
- On liquid-cooled models remove water pump housing and water pump impeller.
- Install special puller (Figure 89) and remove shaft assembly. If puller is not available, refer task to an authorized dealer. Refer shaft component inspection and repair to a dealer.

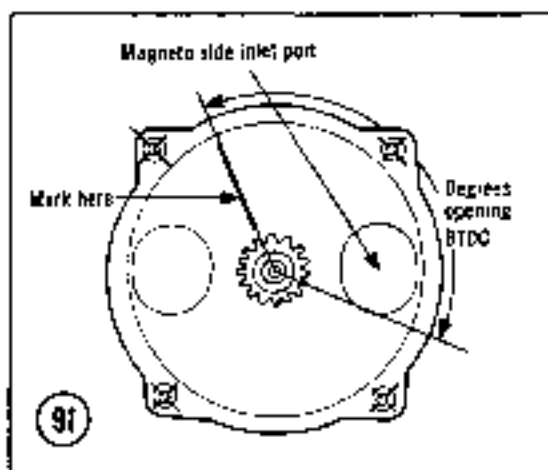
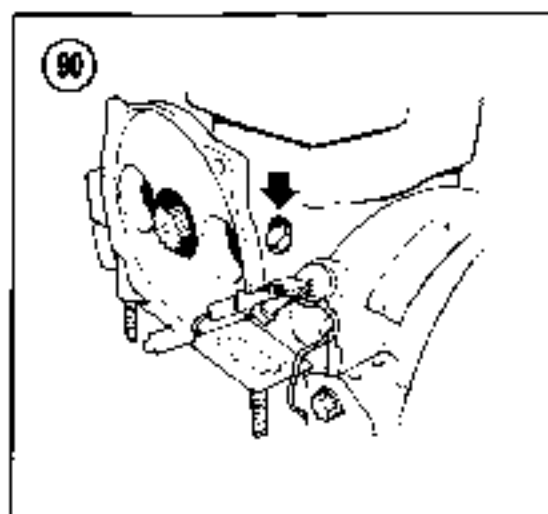

5. Secure valve disc with washer and screw. Install rotary valve cover. Ensure that O-ring is properly positioned. Install carburetors.

Rotary Valve Timing

Refer to Table 5 for timing specifications.

1. Perform *Rotary Valve Removal*.
2. Rotate magneto side piston to TDC (top dead center). Use a dial indicator type timing gauge as described in Chapter One. On 354 engines, install special locking bolt to hold magneto side piston at TDC (Figure 90).
3. Use a protractor or degree wheel and mark stop opening point from *bottom* edge of magneto side inlet port as shown in Figure 91.

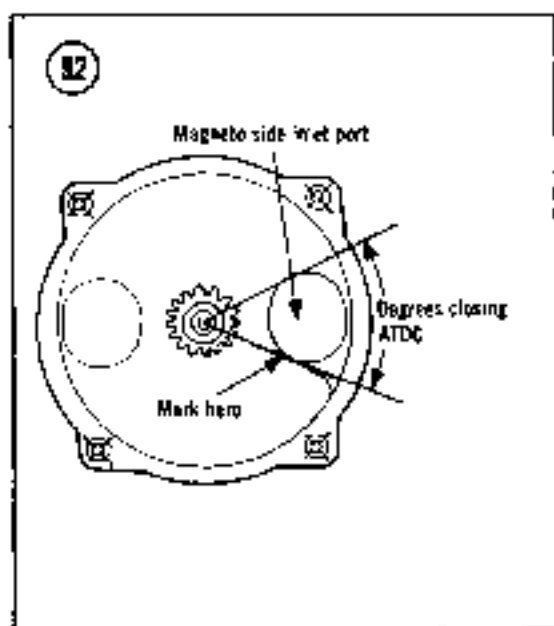

4. With protractor or degree wheel mark stop closing point from *top* edge of inlet port as shown in Figure 92.

5. Proceed to Step 3b of *Rotary Valve Installation*.

Cooling Fan Disassembly/Assembly

This procedure requires a special tool to remove fan from fan housing. If special tool or locally fabricated equivalent is not available, refer task to an authorized dealer.

Refer to Figure 93 for a typical cooling fan assembly.

1. Remove fan housing.
2. Install fan holder tool to hold fan and remove fan nut (Figure 94).
3. Remove lockwasher with outer half of pulley, shims, inner pulley, shim, Woodruff key and fan (Figure 95).

NOTE: Newer type pulley half is constructed without a shoulder on the inner face (Figure 96). A 0.230 in. (6mm) spacer must be installed with a new style pulley half.

4. Remove bearings from fan housing.

NOTE: It may be necessary to heat fan housing in an oven to 140°-160°F (50°-71°C) to aid bearing removal. Use a hammer and a block of wood to gently tap bearings from housing.

5. Remove 2 shims from between bearings when bearings are removed. Remove circlip from fan housing if desired.

Table 5 ROTARY VALVE TIMING SPECIFICATIONS

Engine	Degrees Opening B.T.D.C.	Degrees Closing A.T.D.C.
245, 345	127	48
354 (1975)	131	52
119791	132	50
444 (1975)	140	51
119791	139	49
454	137	65

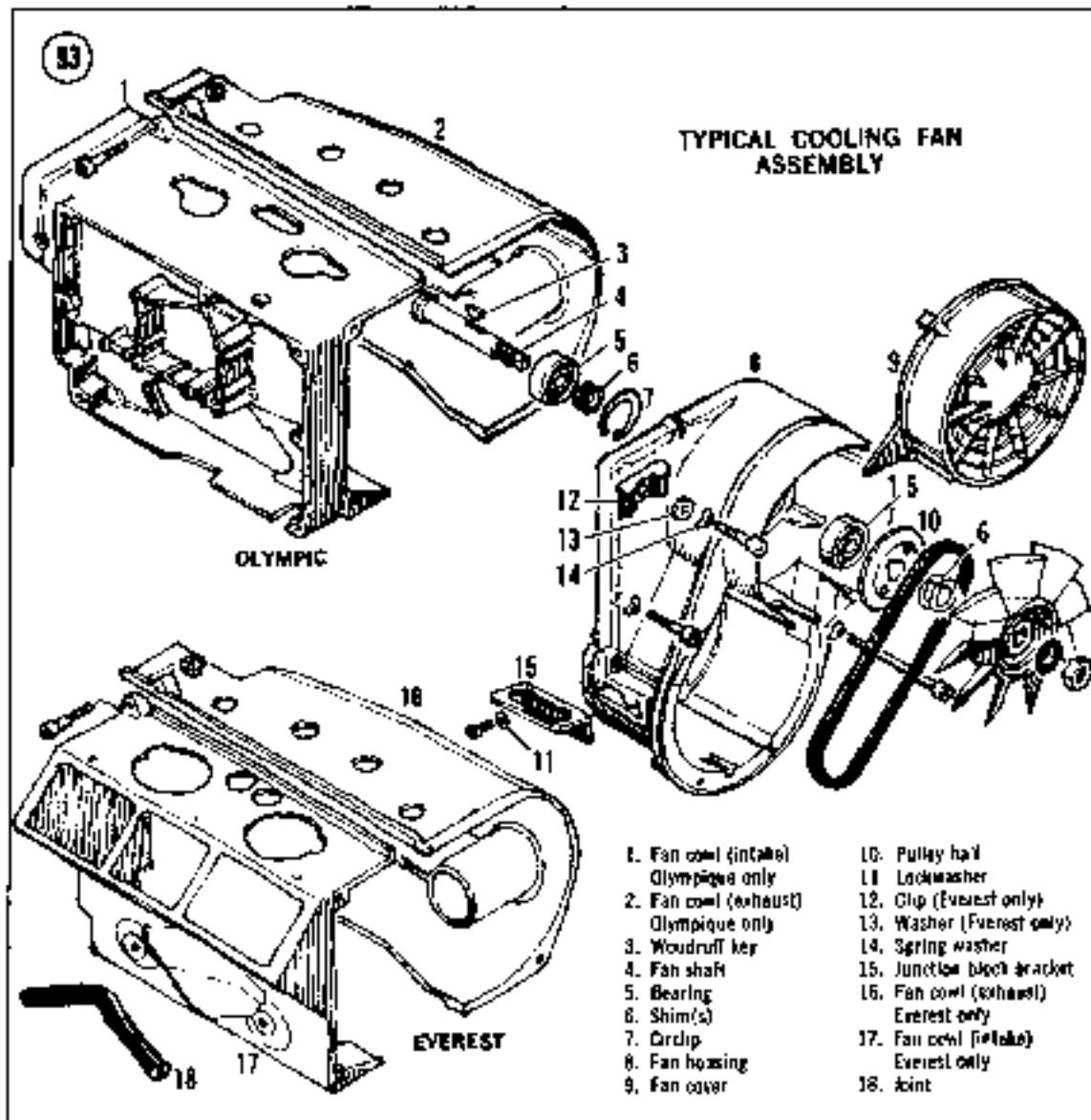

6. Carefully inspect bearings for evidences of roughness or excessive wear and replace if necessary. Refer to *Component Inspection*.

7. Assembly is the reverse of these steps. Keep the following points in mind:

- Lubricate bearings with light oil and insert one bearing into housing. Hear fan housing if necessary to aid bearing installation.
- Install 2 washers against face of installed bearing and install second bearing. Bearing shields must face outward.

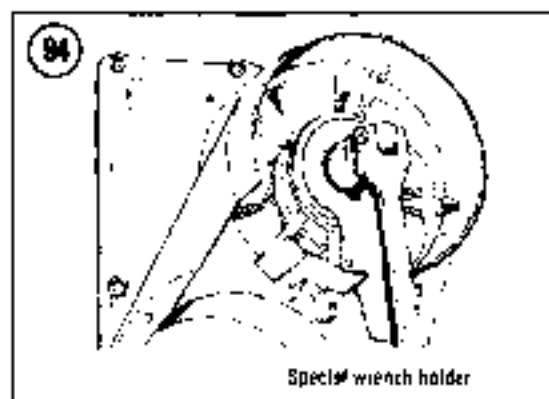

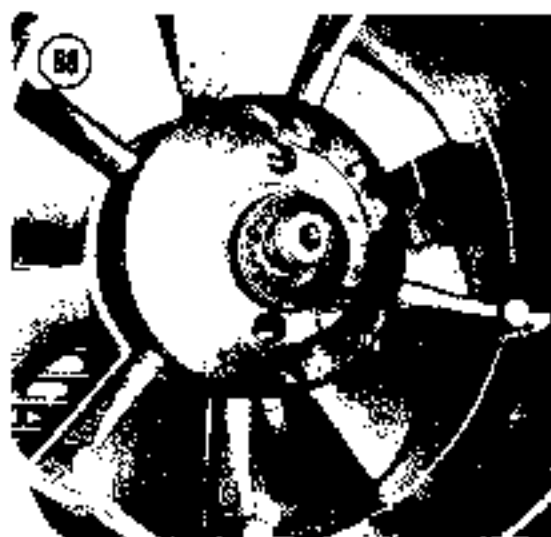
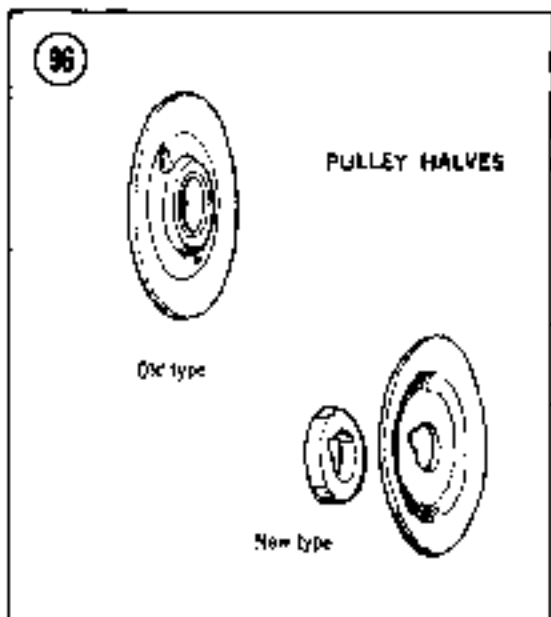
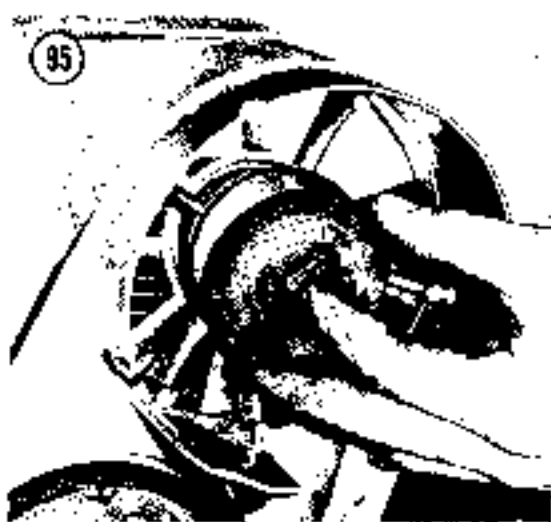

- c. Do not tighten fan nut at this time. Install fan housing and perform *Fan Belt Adjustment*.

Fan Belt Adjustment

1. Check fan belt for approximately $\frac{1}{4}$ in. (6mm) deflection as shown in Figure 97.
2. If belt tension is incorrect, remove fan protector. Use special holding tool to hold fan and remove fan nut (Figure 94).
3. Remove or install shims between inner and outer pulley halves until specified tension is

achieved. Extra shims can be stored under the fan nut (Figure 98).

4. Torque fan nut as specified in Table 1. Recheck fan belt tension and readjust if necessary.

5. Install fan protector onto fan housing.

RECOIL STARTER

Removal/Installation

Remove 4 bolts securing recoil starter assembly to engine and lift off starter (Figure 99). Installation is the reverse of removal.

Disassembly

Refer to **Figure 100** for this procedure.

1. Pull out rope and hold. Use an ice pick or similar sharp tool and disengage key clamp from rope (**Figure 101**). Remove rope from sheave and hand grip.

NOTE: On some early models, starter rope was secured by a jam pin through the center of the sheave hub. On these models, remove circlip, cover washer, and pivoting arm assembly to expose rope end loop and jam pin on back of sheave. Remove rope from sheave, taking care not to lose jam pin.

2. Remove circlip, cover washer, and pivot arm assembly complete with friction washers. Do not disassemble pivot arm assembly unless worn and replacement parts are necessary.
3. Remove "D" washer and rope sheave.
4. Gently tap on outside starter housing to remove spring cartridge.
5. Pry spring cartridge open with a small screwdriver and remove spring.

WARNING

Exercise great care when opening spring cartridge. Spring is tightly wound and may fly out causing injury.

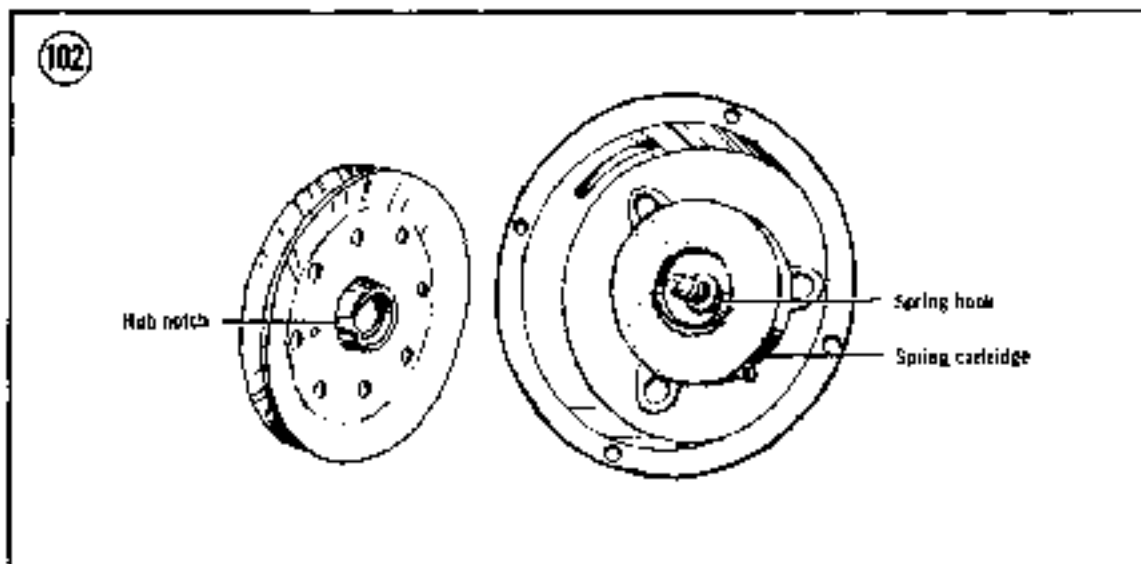
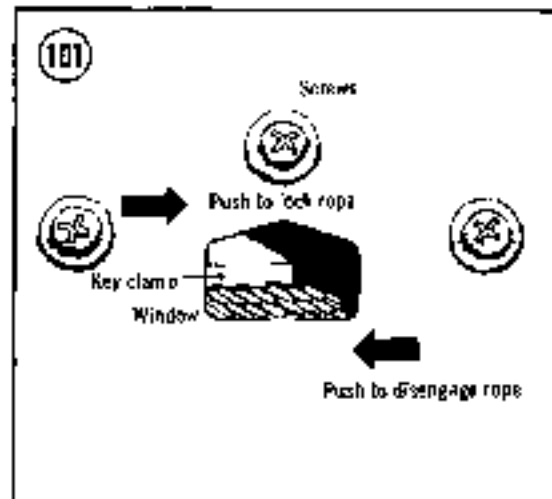

Assembly

1. Wind spring into smaller half of cartridge case. Lightly grease spring as it is wound into case. Install case cover.
2. Install spring cartridge in starter housing with large opening of cartridge facing up. Gently tap cartridge into place.
3. Install rope sheave in housing and align notch in sheave with spring hook (Figure 102).

NOTE: On early model jam pin starters, secure rope end in sheave with jam pin and tap rope end until it is flush with back of sheave.

4. Install "D" washer and complete pivot arm assembly with friction washers.

5. Secure pivot arm assembly with circlip. Ensure that pivot arm is positioned so that arm can turn clockwise.
6. Fuse rope ends with a match.
7. Install rope end in hand grip and secure with knot.
8. Rotate sheave counterclockwise 6 turns to wind up rewind spring and hold.
9. Look through rope hole in starter housing and turn sheave until hole in sheave aligns with hole in housing.
10. Route rope through housing and into sheave hole until approximately $\frac{1}{2}$ in. (19mm) of rope is visible in housing.
11. Install key in housing and push key to lock rope (Figure 101).

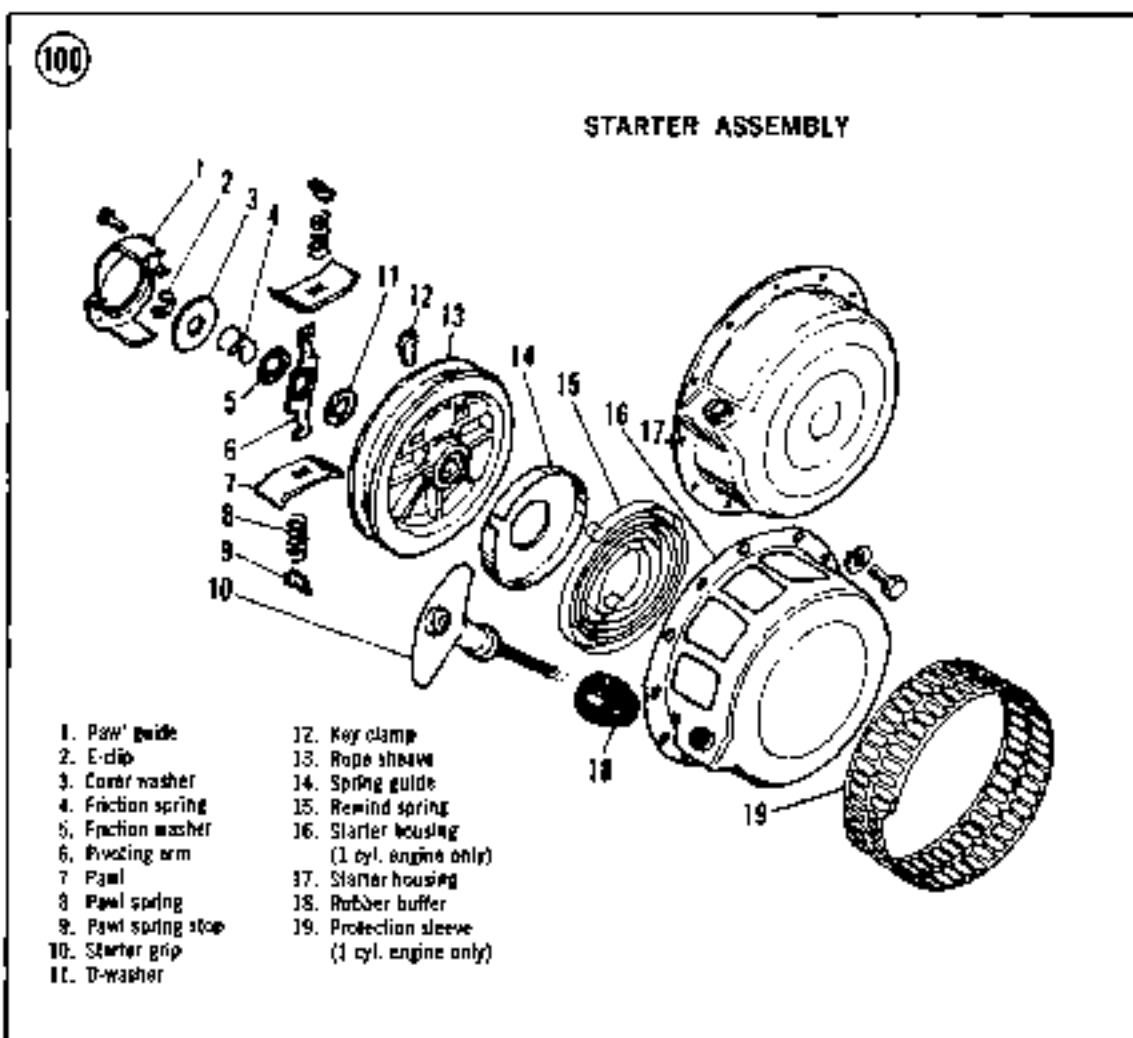

Table 1 TORQUE SPECIFICATIONS

Engine	Engine Assembly to Frame	Engine Mount to Crankcase	Cylinder Bolt/ Nut	Cylinder Head Nut	Magneto Nut	Fan Nut	Intake/Exhaust Manifold Bolt/ Nut
247 and 252	27-25 ft-lb (36.3 N-m)	to 1973 50 ft-lb (6.4 mkg) 1974 and later 33.0 ft-lb (4.24 mkg)	18 ft-lb (2.2 mkg)	to 1973 16-18 ft-lb (2.2-2.5 mkg) 14.5 1974 and later 18 ft-lb (2.4 mkg)	55-66 ft-lb (8.9-7.7 mkg)	N/A	18 ft-lb (2.2 mkg)
245 and 245	22-25 ft-lb (3.0-3.3 mkg)	to 1977 23-25 ft-lb (3.2-4.0 mkg) 1978 and later 25 ft-lb (3.5 mkg)	16 ft-lb (2.2 mkg) After cap screws to 1 ft-lb (1.5 mkg)	to 1977 16-18 ft-lb (2.2-2.5 mkg) 1978 and later 17 ft-lb (2.3 mkg)	53-62 ft-lb (7.2-8.6 mkg)	N/A	16 ft-lb (2.2 mkg)
248 and 248	27-25 ft-lb (3.6-3.3 mkg)	23-25 ft-lb (3.2-4.0 mkg)	16 ft-lb (2.2 mkg) Bolts 11-12 5 ft-lb (1.2 mkg)	14-16 ft-lb (1.9-2.2 mkg)	to 1977 42-50 ft-lb (5.6-6.9 mkg) 1978 and later 46 ft-lb (6.4 mkg)	to 1977 12-17 ft-lb (1.7-2.3 mkg) 1974 and later 12-50 ft-lb (5.8-6.9 mkg)	15 ft-lb (2.1 mkg)
305 316 343 401 and 402	27-25 ft-lb (3.6-3.5 mkg)	23-25 ft-lb (3.2-4.0 mkg)	14-16 ft-lb (1.9-2.2 mkg)	14-16 ft-lb (1.9-2.2 mkg)	to 1977 42-50 ft-lb (5.6-6.9 mkg) 1978 and later 50 ft-lb (6.8 mkg)	to 1977 12-17 ft-lb (1.7-2.3 mkg) 1974 and later 42-50 ft-lb (5.6-6.9 mkg)	14-16 ft-lb (1.9-2.2 mkg)
345 396 and 416	22-25 ft-lb (3.0-3.5 mkg)	20-15 ft-lb (3.1-4.0 mkg)	14-16 ft-lb (1.9-2.2 mkg)	14-16 ft-lb (1.9-2.2 mkg)	56-62 ft-lb (8.0-7.6 mkg)	N/A	14-15 ft-lb (1.9-2.2 mkg)
354	27-25 ft-lb (3.6-3.5 mkg)	28 ft-lb (3.6 mkg)	16 ft-lb (2.2 mkg) Bolts 15, 16 16 ft-lb (2.4 mkg)	16-18 ft-lb (2.2 mkg) 1979 16 ft-lb (2.2 mkg)	75-82 ft-lb (10.3-10.4 mkg)	N/A	15 ft-lb (2.1 mkg)
434 and 443	22-25 ft-lb (3.0-3.5 mkg)	29-35 ft-lb (4.0-4.8 mkg)	14-16 ft-lb (1.9-2.2 mkg)	14-16 ft-lb (1.9-2.2 mkg)	424 51-56 ft-lb (6.9-8.0 mkg) 430 53-63 ft-lb (8.0-8.7 mkg)	to 1977 12-17 ft-lb (1.7-2.3 mkg) 1974 and later 42-50 ft-lb (5.8-6.9 mkg)	14-15 ft-lb (1.9-2.2 mkg)
444 and 454	22-25 ft-lb (3.0-3.5 mkg)	26 ft-lb (3.6 mkg)	16 ft-lb (2.2 mkg)	1978-12 ft-lb (1.7 mkg) 1979-26 ft-lb (3.5 mkg)	60 ft-lb (8.3 mkg)	N/A	15 ft-lb (2.1 mkg)
505	22-25 ft-lb (3.0-3.5 mkg)	26 ft-lb (3.5 mkg)	16 ft-lb (2.2 mkg)	16 ft-lb (2.2 mkg)	60 ft-lb (8.3 mkg)	46 ft-lb (6.4 mkg)	15 ft-lb (2.1 mkg)

Table 2 SINGLE CYLINDER ENGINE SPECIFICATIONS

Engine	Cylinder Bore (Standard)	Wear Limit	Ring End Gap	Crankshaft End Play
247	2.7165 in. (69.0mm)	0.0065 in. (0.165mm)	0.010-0.063 in. (0.25-1.60mm)	0.004-0.016 in. (0.10-0.40mm)
292	2.9528 in. (75.0mm)	0.0076 in. (0.195mm)	0.012-0.063 in. (0.30-1.60mm)	0.004-0.016 in. (0.10-0.40mm)
300, 302	2.9921 in. (76.0mm)	0.0076 in. (0.195mm)	0.012-0.063 in. (0.30-1.60mm)	0.004-0.016 in. (0.10-0.40mm)
335, 337	3.0709 in. (78.0mm)	0.0076 in. (0.195mm)	0.012-0.063 in. (0.30-1.60mm)	0.004-0.016 in. (0.10-0.40mm)

Table 3 TWIN CYLINDER ENGINE SPECIFICATIONS

Engine Type	Cylinder Bore (Standard)	Wear Limit	Ring End Gap	Crankshaft End Play
245	2.1260 in. (54.0mm)	0.0069 in. (0.175mm)	0.008-0.020 in. (0.20-0.50mm)	0.040-0.016 in. (0.10-0.40mm)
248	2.1260 in. (54.0mm)	0.0053 in. (0.135mm)	0.008-0.063 in. (0.20-1.60mm)	0.004-0.016 in. (0.10-0.40mm)
248 (1978-1979)	2.1260 in. (54.0mm)	0.0053 in. (0.135mm)	0.006-0.014 in. (0.15-0.35mm)	0.004 in. (0.10mm)
294	2.2441 in. (57.0mm)	0.0053 in. (0.135mm)	0.008-0.063 in. (0.20-1.60mm)	0.004-0.016 in. (0.10-0.40mm)
305	2.1850 in. (55.5mm)	0.0053 in. (0.135mm)	0.008-0.063 in. (0.20-1.60mm)	0.004-0.016 in. (0.10-0.40mm)
305 (1978)	2.1850 in. (55.5mm)	0.0068 in. (0.172mm)	0.006-0.014 in. (0.15-0.35mm)	0.009 in. (0.10mm)
338	2.3425 in. (59.5mm)	0.0076 in. (0.195mm)	0.008-0.063 in. (0.20-1.60mm)	0.004-0.016 in. (0.10-0.40mm)
343	2.3425 in. (59.5mm)	0.0076 in. (0.195mm)	0.008-0.063 in. (0.20-1.60mm)	0.004-0.016 in. (0.10-0.40mm)
343 (1978)	2.3425 in. (59.5mm)	0.0076 in. (0.195mm)	0.006-0.014 in. (0.15-0.35mm)	0.004 in. (0.10mm)
343 (1979)	2.3425 in. (59.5mm)	0.008 in. (0.20mm)	0.006-0.014 in. (0.15-0.35mm)	0.004 in. (0.10mm)
345	2.4903 in. (63.0mm)	0.0053 in. (0.135mm)	0.008-0.020 in. (0.20-0.50mm)	N/A
345 (1978)	2.4903 in. (63.0mm)	0.0053 in. (0.135mm)	0.008-0.015 in. (0.20-0.40mm)	N/A
346	2.3425 in. (59.5mm)	0.0092 in. (0.235mm)	0.008-0.063 in. (0.20-1.60mm)	N/A

(continues)

Table 3 TWIN CYLINDER ENGINE SPECIFICATIONS (continued)

Engine Type	Cylinder Bore (Standard)	Wear Limit	Ring End Gap	Crankshaft End Play
346 (1978)	2.3425 in. (59.5mm)	0.0092 in. (0.235mm)	0.006-0.014 in. (0.15-0.35mm)	N/A
354 (1978)	2.3425 in. (59.5mm)	0.0076 in. (0.195mm)	0.006-0.014 in. (0.15-0.35mm)	N/A
354 (1979)	2.3425 in. (59.5mm)	0.008 in. (0.20mm)	0.006-0.014 in. (0.15-0.35mm)	0.004 in. (0.10mm)
396	2.5394 in. (64.5mm)	0.0064 in. (0.215mm)	0.010-0.063 in. (0.25-1.60mm)	N/A
401	2.5394 in. (64.5mm)	0.0076 in. (0.195mm)	0.010-0.063 in. (0.25-1.60mm)	0.004-0.016 in. (0.10-0.40mm)
434	2.6575 in. (67.5mm)	0.0076 in. (0.195mm)	0.010-0.063 in. (0.25-1.60mm)	N/A
436	2.6575 in. (67.5mm)	0.011 in. (0.285mm)	0.010-0.063 in. (0.25-1.60mm)	N/A
440	2.6575 in. (67.5mm)	0.0086 in. (0.216mm)	0.010-0.063 in. (0.25-1.60mm)	N/A
440 (1978)	2.6575 in. (67.5mm)	0.0069 in. (0.175mm)	0.008-0.016 in. (0.20-0.40mm)	N/A
440 (1979)	2.6575 in. (67.5mm)	0.007 in. (0.18mm)	0.008-0.016 in. (0.20-0.40mm)	0.004 in. (0.10mm)
444 (1976-1979)	2.7362 in. (69.5mm)	0.007 in. (0.18mm)	0.008-0.016 in. (0.20-0.40mm)	0.004 in. (0.10mm)
454	2.6575 in. (67.5mm)	0.009 in. (0.22mm)	0.008-0.016 in. (0.20-0.40mm)	0.004 in. (0.10mm)
503	2.8346 in. (72mm)	0.006 in. (0.16mm)	0.008-0.016 in. (0.20-0.40mm)	0.004 in. (0.10mm)

* Not applicable on 1976 models

CHAPTER FIVE

FUEL SYSTEM

The fuel system consists of a fuel tank, fuel lines, inline fuel filter, and carburetor(s).

All models are equipped with one of 2 types of carburetor, a Tillotson or Mikuni. Tillotson carburetors have an integral fuel pump. Mikuni carburetors are provided fuel through an auxiliary impulse fuel pump operating off differential pressure in the engine crankcase. An air silencer is fitted on some models to quiet incoming air and catch fuel that may spit back out of the carburetor.

This chapter covers removal, installation, and replacement and/or repair of carburetors, fuel pumps, inline filters, and fuel tanks. Carburetor tuning is covered in Chapter Two.

See **Table 1** or **2** at the end of the chapter for carburetor application and specifications.

TILLOTSON CARBURETOR

Three basic types of Tillotson carburetors are used: the HR, HD, and HRM. Refer to **Table 1** for model application. Refer to **Figures 1** and **2** for typical examples of HR and HD type carburetors. Refer to **Figure 3** for a typical example of HRM types.

Removal/Installation

1. Remove air intake silencer (**Figure 4**) on models so equipped.



2. Disconnect throttle and choke cables from carburetor.

3. Disconnect fuel lines. Tag fuel line to aid installation.

4. Open tab locks (**Figure 5**) and remove nuts and washers securing carburetor to engine.

5. Remove carburetor with isolating sleeves and gaskets (**Figure 6**). If applicable, also remove isolating flange and gasket (**Figure 7**).

6. Installation is the reverse of these steps. Keep the following points in mind:

- Longer fuel line is return line and is connected to outlet nipple on carburetor.
- Perform carburetor adjustments as outlined in Chapter Two.

① A

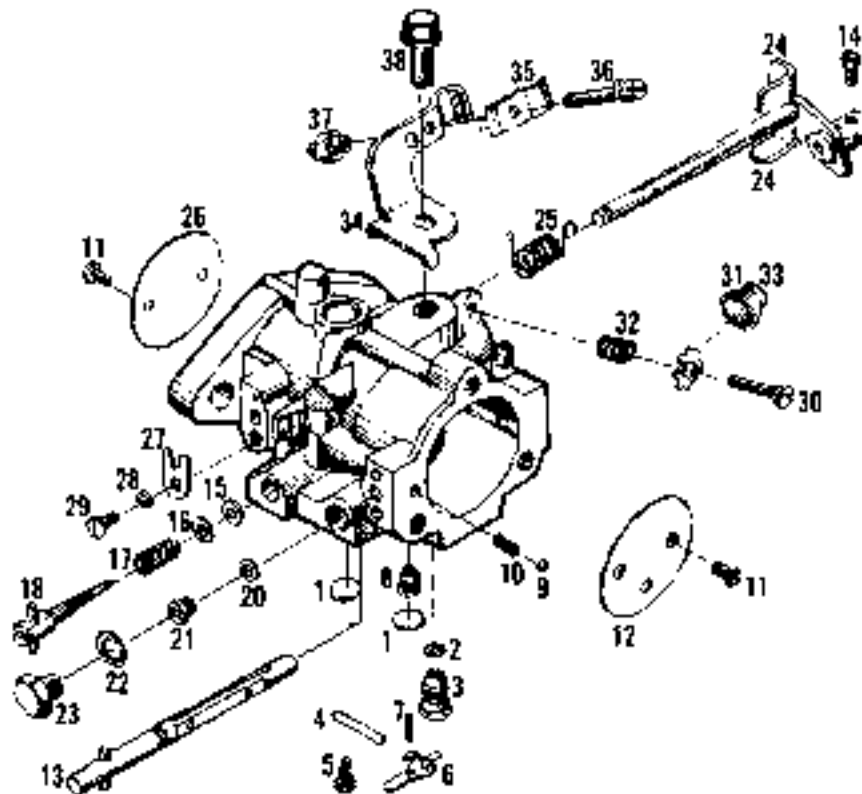

TYPICAL HR TYPE CARBURETOR

- | | |
|--|------------------------------------|
| 1. Welch plug | 25. Throttle shaft spring |
| 2. Inlet seat gasket | 26. Throttle shutter |
| 3. Inlet needle and seat | 27. Throttle shaft clip |
| 4. Fulcrum pin | 28. Lockwasher |
| 5. Retaining screw | 29. Retaining screw |
| 6. Fulcrum lever | 30. Idle speed adjusting screw |
| 7. Fulcrum lever spring | 31. Washers |
| 8. Main nozzle check valve | 32. Adjusting screw spring |
| 9. Friction ball | 33. Cup |
| 10. Friction spring | 34. Throttle cable bracket |
| 11. Shutter screw | 35. Throttle cable clamp |
| 12. Choke shutter | 36. Cable clamp retaining screw |
| 13. Choke shaft | 37. Cable clamp retaining nut |
| 14. Wire retaining screw | 38. Retaining screw and lockwasher |
| 15. Packing | 39. Diaphragm gasket |
| 16. Washer | 40. Metering diaphragm |
| 17. Adjusting screw spring | 41. Diaphragm cover |
| 18. Idle mixture adjusting screw | 42. Fuel pump gasket |
| 19. High speed mixture adjusting screw | 43. Fuel pump diaphragm |
| 20. Main fuel jet gasket | 44. Fuel pump body |
| 21. Main fuel jet | 45. Inlet valve gasket |
| 22. Plug screw gasket | 46. Inlet valve diaphragm |
| 23. Main jet plug screw | 47. Inlet valve body |
| 24. Throttle shaft | 48. Fuel strainer screen |
| | 49. Fuel strainer gasket |
| | 50. Body screw and lockwasher |

(T) B

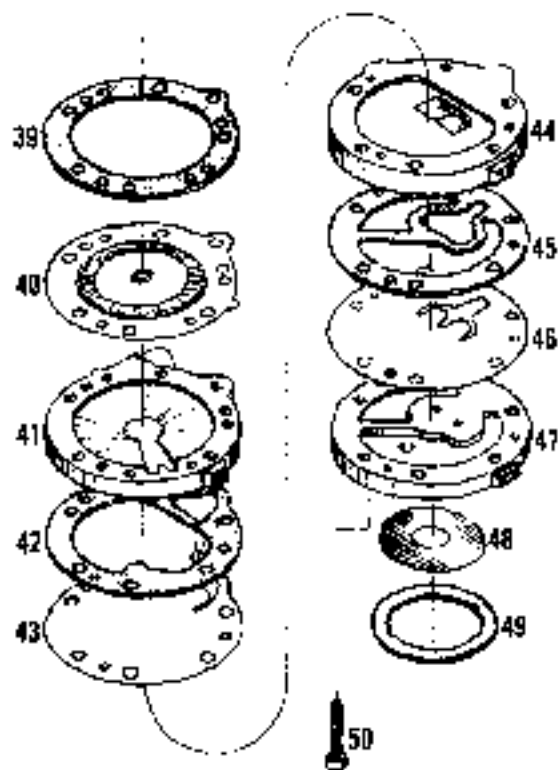

WITH INTEGRATED FUEL PUMP

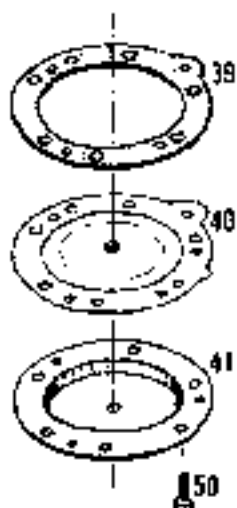

WITHOUT INTEGRATED FUEL PUMP

2 A

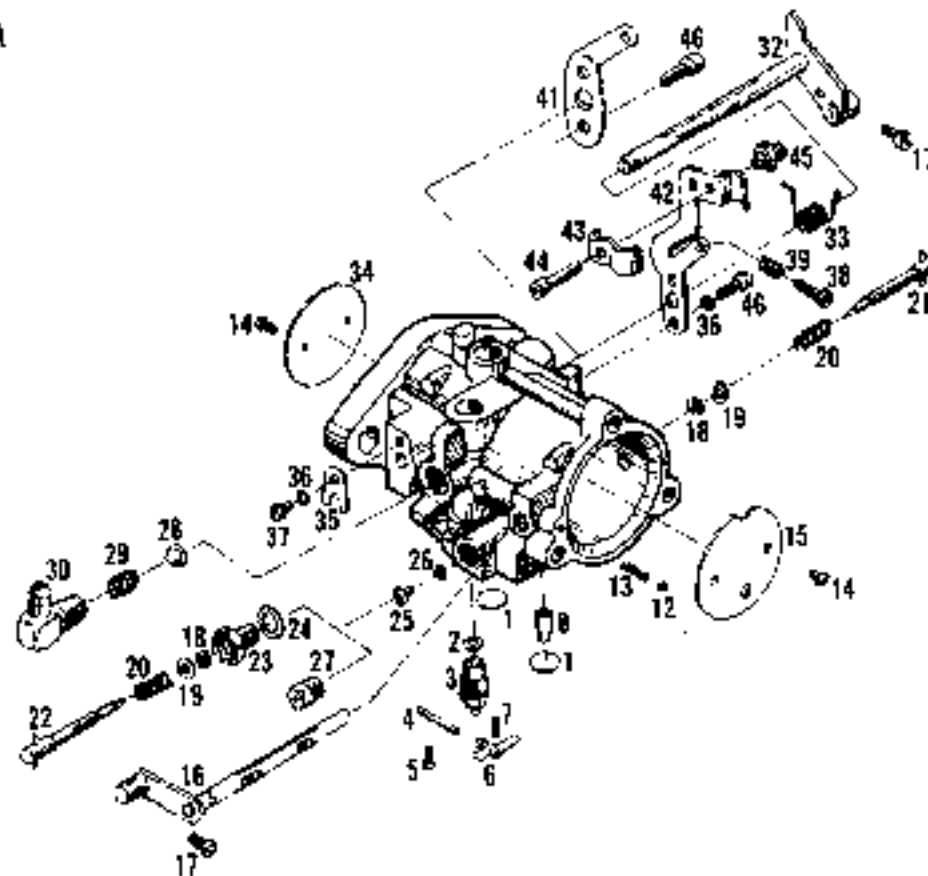

TYPICAL HD TYPE CARBURETOR

- | | | |
|---|--|---------------------------------|
| 1. Welch plug | 20. Adjusting screw spring | 39. Idle speed screw spring |
| 2. Inlet seat gasket | 21. Idle mixture adjusting screw | 40. Idle speed screw cup |
| 3. Inlet needle and seat | 22. High speed mixture adjusting screw | 41. Idle speed screw gasket |
| 4. Fulcrum pin | 23. Mixture screw gland | 42. Throttle cable bracket |
| 5. Retaining screw | 24. Fiber gasket | 43. Throttle cable clamp |
| 6. Fulcrum lever | 25. Main fuel jet | 44. Cable clamp retaining screw |
| 7. Fulcrum lever spring | 26. Main fuel jet gasket | 45. Cable clamp retaining nut |
| 8. Main nozzle check valve | 27. Main fuel jet plug screw | 46. Bracket retaining screw |
| 9. Main nozzle check valve/discharge lede | 28. Inlet screen | 47. Diaphragm gasket |
| 10. Lead shot | 29. Inlet screen retaining spring | 48. Mating diaphragm |
| 11. Intermediate nozzle check valve | 30. Fuel connector | 49. Diaphragm cover |
| 12. Friction ball | 31. Body channel plug screw | 50. Fuel pump gasket |
| 13. Friction spring | 32. Throttle shaft | 51. Fuel pump diaphragm |
| 14. Shutter screw | 33. Throttle shaft spring | 52. Fuel pump body |
| 15. Choke shutter | 34. Throttle shutter | 53. Inlet valve gasket |
| 16. Choke shaft | 35. Throttle shaft clip | 54. Inlet valve diaphragm |
| 17. Wire retaining screw | 36. Lockwasher | 55. Inlet valve body |
| 18. Packing | 37. Retaining screw | 56. Fuel strainer screen |
| 19. Washer | 38. Idle speed screw | 57. Fuel strainer gasket |
| | | 58. Body screw and lockwasher |

2 8

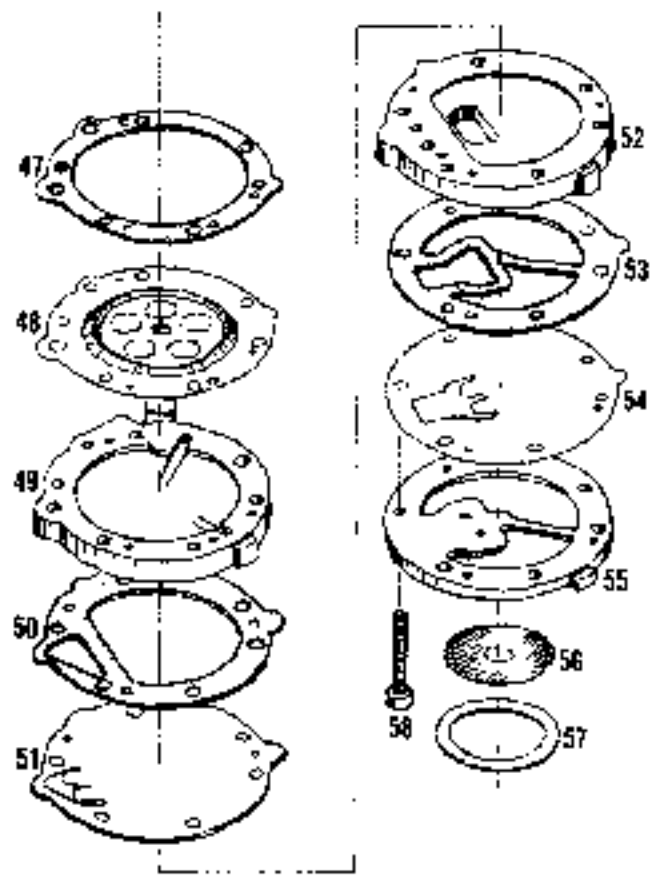

WITH INTEGRATED FUEL PUMP

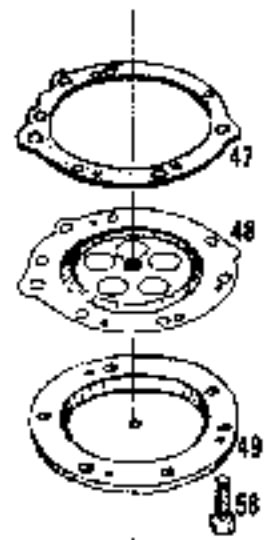

WITHOUT INTEGRATED FUEL PUMP

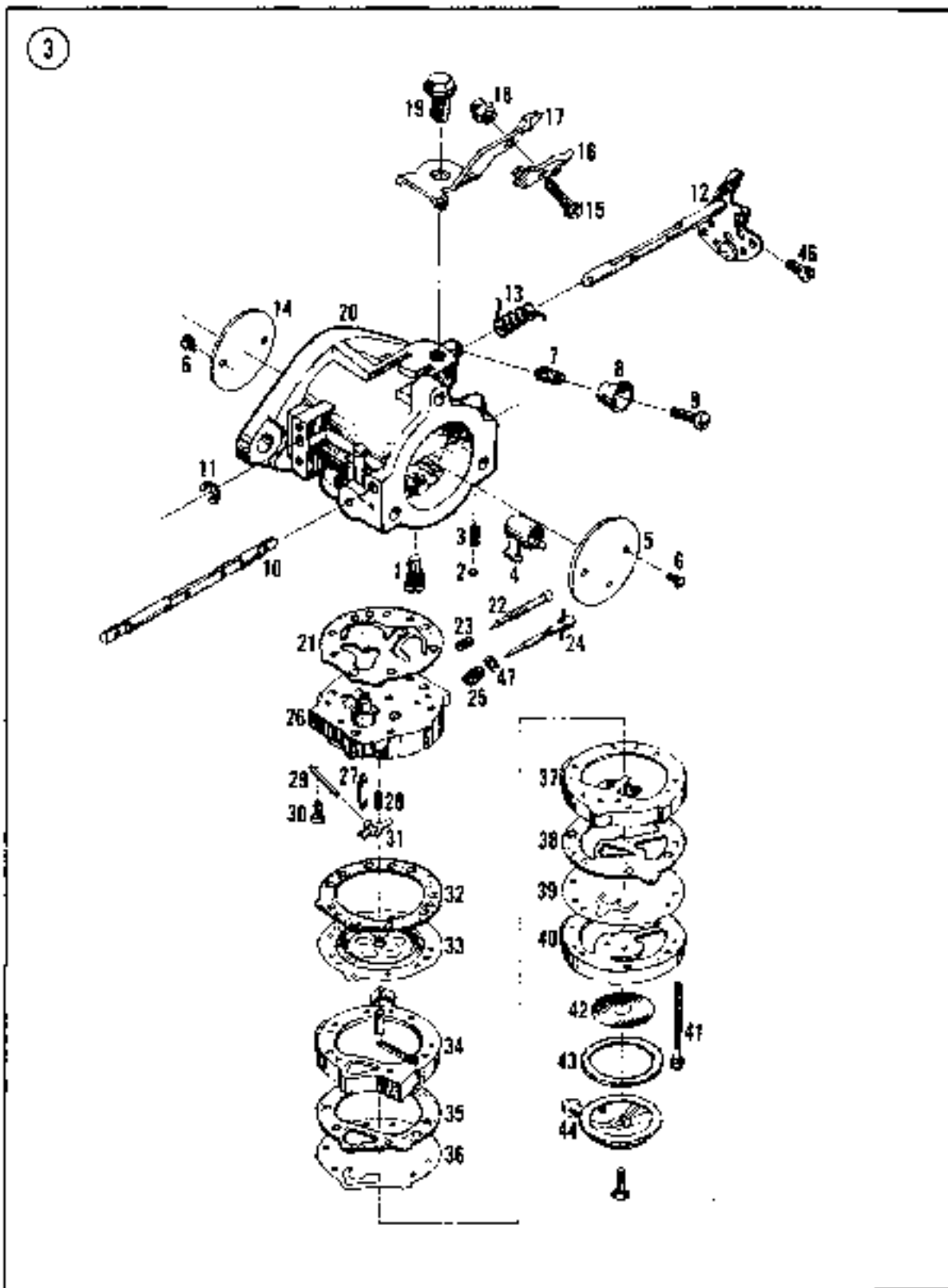

TYPICAL HRM TYPE CARBURETOR

1. Nozzle check valve
- *2. Friction ball
- *3. Spring
4. Primary venturi
- *5. Choke shutter
- *6. Screw
7. Spring
8. Cup
9. Idle speed screw
- *10. Choke shaft
11. Circlip
12. Throttle shaft
13. Spring
14. Throttle shutter
- *15. Screw
- *16. Throttle cable clamp
- *17. Throttle cable bracket
- *18. Nut
- *19. Bolt
20. Carburetor body
21. Adjuster
22. Idle mixture screw
23. Spring
24. High speed mixture screw
25. Spring
26. Adjustment module
27. Inlet needle
28. Inlet tension spring
29. Fulcrum pin
30. Retaining screw
31. Inlet control lever
32. Diaphragm gasket
33. Metering diaphragm
34. Diaphragm cover
35. Fuel pump gasket
36. Fuel pump diaphragm
37. Fuel pump body
38. Inlet valve gasket
39. Inlet valve diaphragm
40. Body screw and lockwasher
42. Fuel strainer screen
43. Cover gasket
44. Fuel strainer cover
45. Cover retaining screw
46. Cable retaining screw
- **47. Washer

* Not applicable on HRM 5A

** Applicable only on HRM 5A and HRM 7A

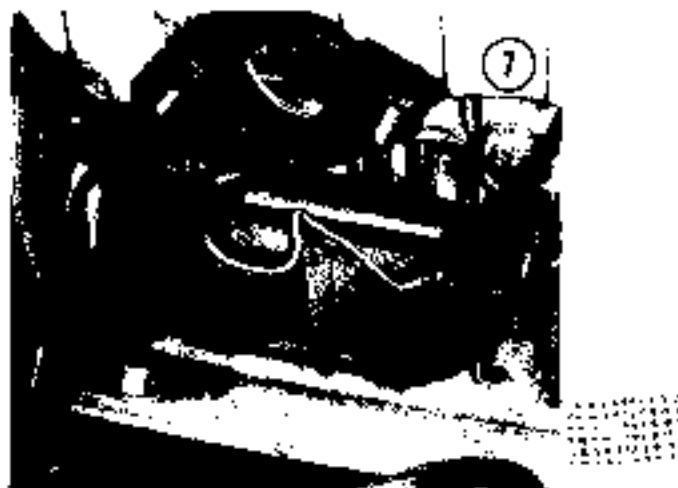

Disassembly

Refer to Figure 1 and 2 for HD and HR types and Figure 3 for HRM type carburetors.

1. Clean exterior of carburetor with a non-flammable solvent.

CAUTION

Never use compressed air to clean an assembled carburetor or disassembly may be damaged.

2. Carefully disassemble carburetor. Pay particular attention to location of different sized screws and springs.

3. If necessary to remove Welch plugs from carburetor body, carefully pierce plug with a sharp tool such as an awl and pry plug out of carburetor.

CAUTION

Exercise care when removing choke shaft or choke friction ball and spring may fly out and be lost.

Carefully remove inlet control lever as it is spring loaded and can fly out when retaining screw is removed.

Main fuel jet has left-hand threads. To remove, turn jet clockwise.

4. If removing main nozzle check ball assembly (beneath Welch plug), perform the following:
 - a. On HR type carburetors, unscrew main nozzle check ball assembly.
 - b. On HD type carburetors, use a small punch and gently tap out main nozzle check ball assembly.

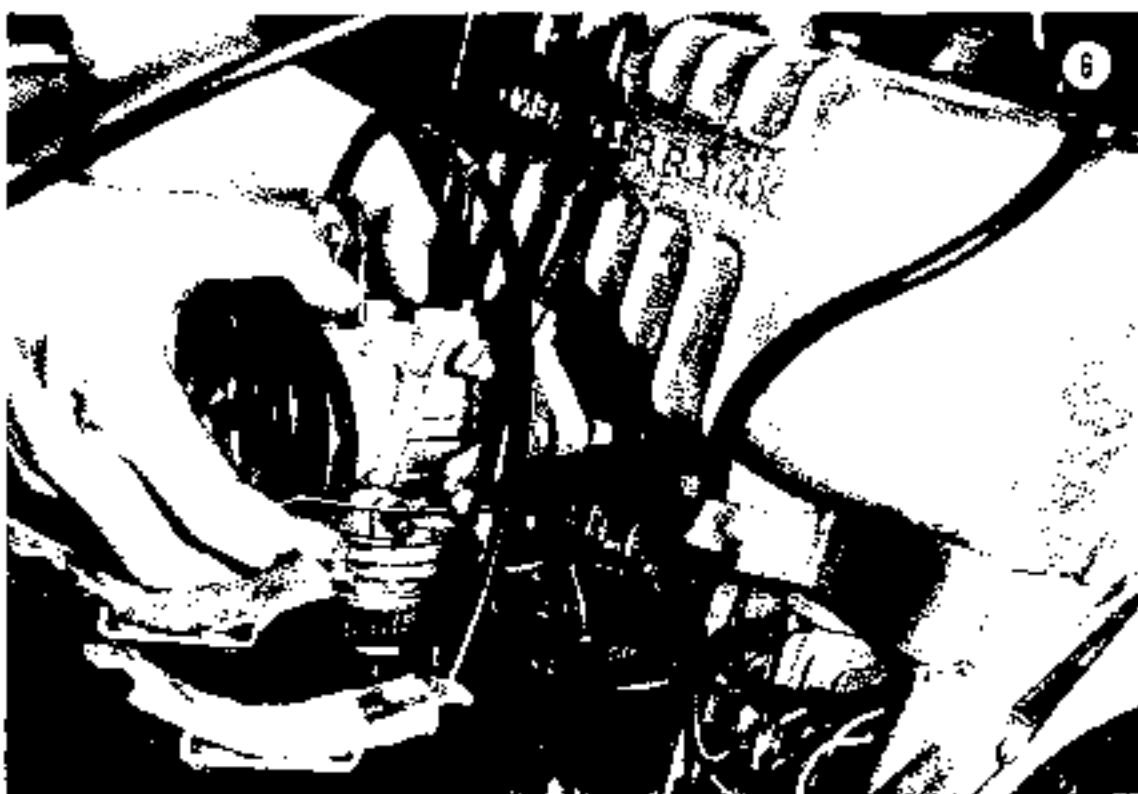
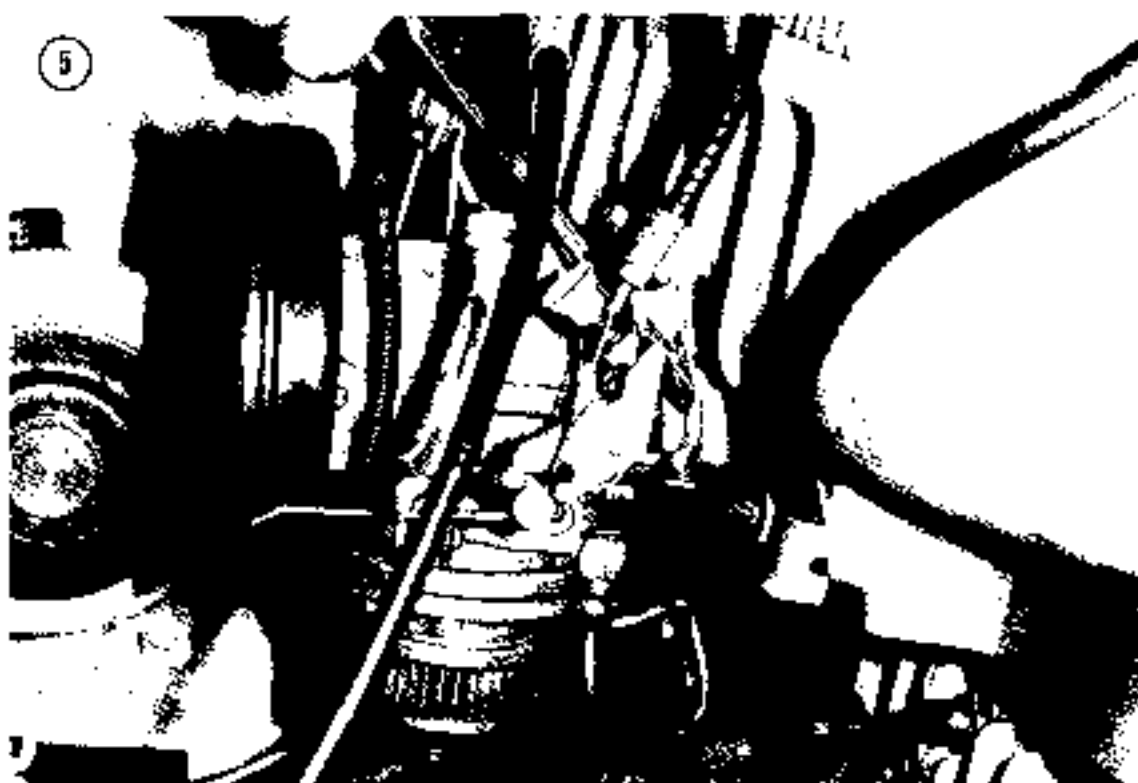

5. When carburetor is fully disassembled, perform *Cleaning and Inspection*.

Cleaning and Inspection

WARNING

Most carburetor cleaners are highly caustic. They must be handled with extreme care or skin burns and possible eye injury may result.

1. Clean all metallic parts in carburetor cleaning solvent. Do not place gaskets or diaphragms in solvent or they will be destroyed.

CAUTION

Never clean holes or passages with small drill bits or wire or a slight enlargement or burring of holes will result, drastically affecting carburetor performance.

2. After cleaning carburetor parts, dry with compressed air. Make sure all holes are open and free of carbon and dirt.

NOTE: *Do not use rags or wastepaper to dry parts. Lint may plug jets or channels and affect carburetor operation.*

3. Inspect shaft bearing surfaces in carburetor body (Figure 8) for excessive wear.

CAUTION

If excessive clearance is found between shafts and carburetor body, worn parts must be replaced. Excessive clearance will allow air to enter, causing a damaging lean mixture.

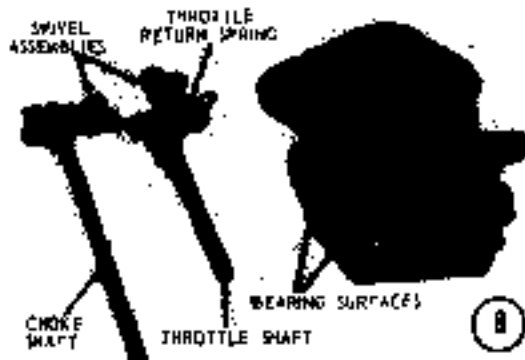

4. Inspect choke and throttle plates for damage. Inspect swivel assemblies on choke and throttle levers for wear. Inspect condition

of throttle return spring. Replace all worn parts.

5. Inspect mixture needles and needle valve seating surfaces for pitting or wear (Figure 9) and replace if worn or damaged.

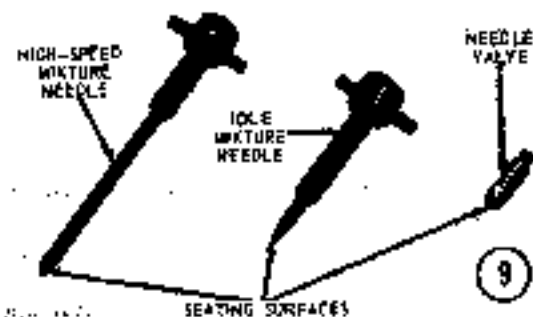

6. Inspect diaphragms for distortion, cracks, or punctures (Figure 10).

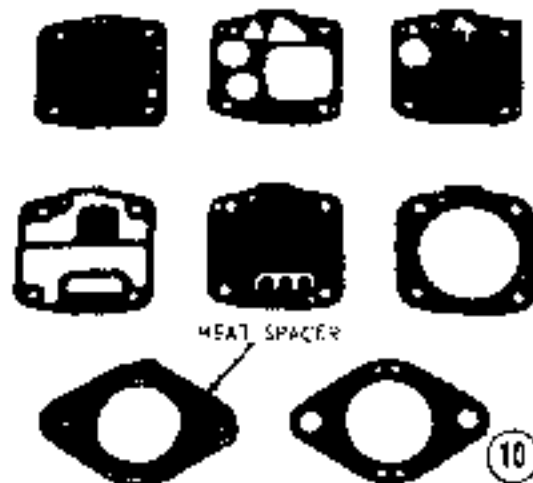

7. Inspect carburetor mounting gasket and heat spacer gasket.

Assembly

Refer to Figures 1 and 2 for HD and HR types and Figure 3 for HRM type carburetors.

1. Install main nozzle check ball assembly (if removed) as follows:
 - a. On HR type carburetor screw assembly in carburetor body.
 - b. On HD type carburetor insert nozzle assembly in carburetor body until nozzle shoulder is flush with bottom of nozzle well.

2. If Welch plugs were removed, install new plugs (convex side up) and tap plug with hammer and punch until plug is flat. Ensure that plug completely seals opening.
3. Place spring, washer, and packing on idle speed mixture screw and install in carburetor. Lubricate packing with petroleum jelly.
4. Install high-speed needle with spring, washer, and packing. Lubricate packing with petroleum jelly.
5. On HR and HD types with fixed main jet install jet with gasket and turn *counterclockwise* to tighten.
6. Insert choke friction spring and ball into carburetor and hold in position while installing choke shaft.

NOTE: On HRM carburetors install primary venturi with largest section toward front of carburetor.

7. Insert choke shutter on shaft and turn shaft to center shutter in carburetor body. Secure choke shutter with screws. Ensure that hole on shutter is down and mark on shutter faces out.
8. Install throttle shaft part way. Connect throttle shaft spring and turn shaft one turn clockwise and finish installing shaft.
9. Install idle speed screw bracket on HD carburetor.
10. Install throttle shaft retainer clip and secure with screw.
11. Insert throttle shutter into throttle shaft with location mark facing out. Close throttle shaft to center shutter in carburetor body and secure shutter with 2 screws.
12. Install inlet needle seat with thin wall socket. Torque seat to 25-30 in.-lb. (29-35 cmkg) on HR types and 40-45 in.-lb. (46-52 cmkg) on HD type carburetors.
13. Install needle seat and inlet control lever. Secure control lever with retaining screw. Adjust inlet control lever so that center of lever that contacts metering diaphragm is flush with metering chamber wall.
14. Assemble pump diaphragm assembly. Install assembly to carburetor and tighten 6 screws evenly in a crisscross pattern (Figure 11).

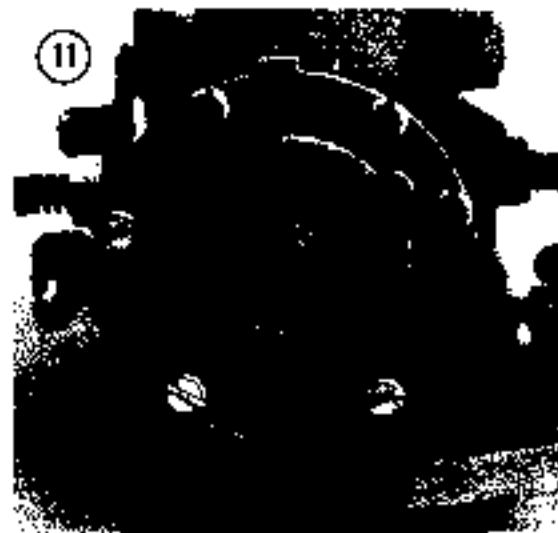

15. Install fuel inlet strainer cover with strainer screen to diaphragm pump body and secure with screw.

MIKUNI CARBURETOR

Refer to Table 2 for model application.

Removal/Installation

1. Remove air filter.
2. Disconnect fuel and primer lines.
3. Unscrew throttle chamber cover and carefully slide throttle slide assembly from carburetor (Figure 12).

NOTE: If carburetor is being removed for cleaning or repair, disconnect throttle cable from throttle slide and remove throttle slide assembly. Note and record what notch E-ring is located in on jet needles to aid installation.

4. Remove drain plug from bottom of float chamber and drain fuel into a suitable container. Install drain plug.
5. Loosen clamp securing carburetor and remove carburetor from rubber mount.
6. Installation is the reverse of these steps. Keep the following points in mind:
 - a. Install E-ring on jet needle in same position noted during removal.
 - b. Ensure that float level is correct. Refer to *Assembly*.



- c. Perform carburetor adjustments as outlined in Chapter Two.

Disassembly

Refer to Figure 13 for this procedure.

1. Remove throttle stop screw and spring.
2. Remove air screw and spring.
3. Remove float chamber as shown in Figure 14. Gently lift out floats from mixing chamber body.

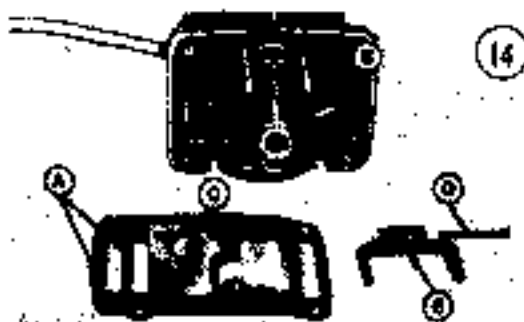

- | | |
|--------------------------------|------------------|
| A. Gaskets | C. Baffle plate |
| B. Inlet needle valve assembly | D. Float air pin |
| | E. Float arm |

4. Using a 6mm socket or box end wrench, gently remove main jet and ring.
5. Remove float arm pin and float arm. Lift off baffle plate and gaskets (Figure 14).
6. Gently remove inlet needle valve assembly with washer.
7. Gently push needle jet from mixing chamber using an awl or similar sharp pointed device. See Figure 15.



- A. Needle jet B. Awl

Cleaning and Inspection

WARNING

Most carburetor cleaners are highly caustic. They must be handled with extreme care or skin burns and possible eye injury may result.

1. Clean all metallic parts in carburetor cleaning solvent. Do not place gaskets in solvent or they will be destroyed.

CAUTION

Never clean holes or passages with small drill bits or wire or a slight enlargement or burring of inside will result, drastically affecting carburetor performance.

2. Inspect float chamber and mixing chamber body for fine cracks or evidence of fuel leaks.
3. Check spring for distortion or damage.
4. Inspect air screw and throttle stop screw for surface damage or stripped threads.
5. Inspect pilot jet and main jet for damage or stripped threads.

CAUTION

Pilot jet and main jet must be scrupulously clean and shiny. Any burring, roughness, or abrasion will cause a lean fuel and air mixture and possible engine damage.

6. Remove retainer and inlet valve from valve seat. Carefully examine seating surface on inlet valve and seat for damage. Ensure that retainer does not bind and hinder movement of inlet valve.
7. Inspect jet needle and needle jet for damage. Jet needle must slide freely within needle jet.

13

MIKUNI CARBURETOR

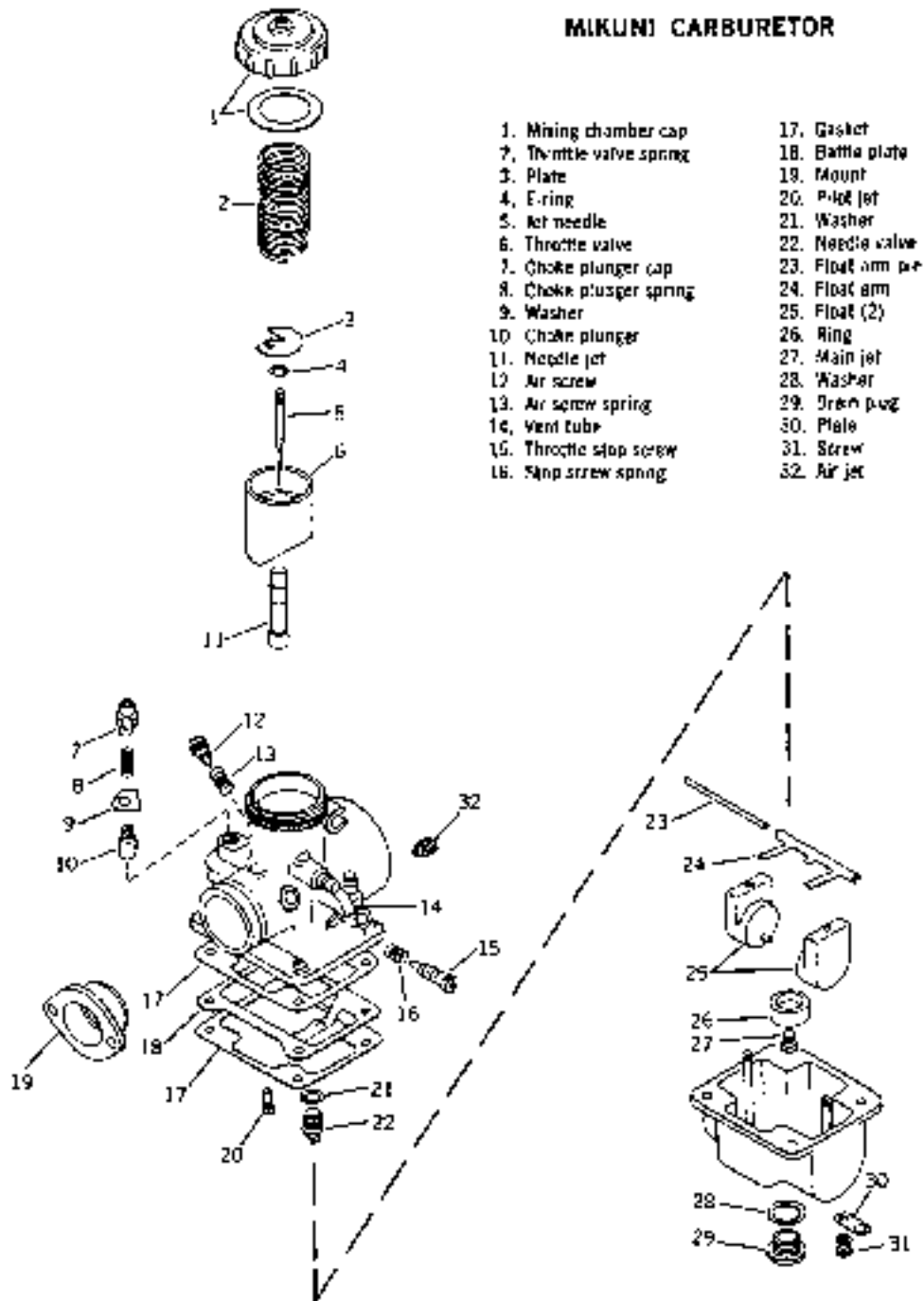

8. Install float guides in float chamber. Move floats up and down several times to ensure that they are not binding on float guides.
9. Inspect float arm and float pin to ensure that float arm does not bind on pin.
10. Inspect choke plunger. Plunger must move freely in passage of mixing chamber.
11. Install throttle valve in mixing chamber body and move several times up and down to check for sticking motion or wear. Ensure that guide pin in mixing chamber body is not broken.

Assembly

Refer to **Figure 13** for this procedure.

1. Using a small screwdriver, install pilot jet in carburetor body as shown in **Figure 16**.



16

2. Install gaskets and baffle plate on mixing chamber surface (**Figure 17**). Install second gasket on top of baffle plate.

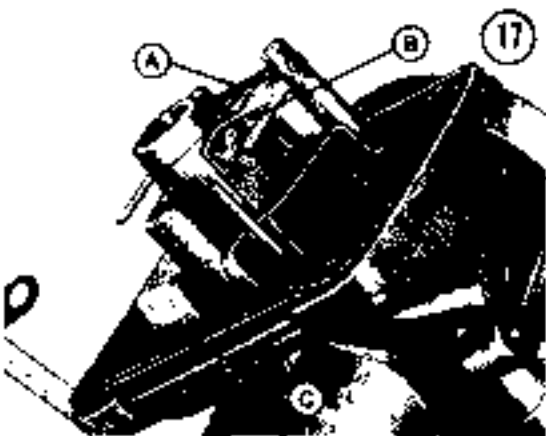

A. Float arm B. Inlet valve C. Baffle plate and gaskets

3. Place washer on inlet needle valve seat and install seat in mixing chamber body (**Figure 17**). Install inlet valve (point down) and retainer.
4. Install float arm and secure float arm with float arm pin.
5. Invert carburetor body. Edge of mixing chamber (**Figure 18**) must be 23-24mm (0.90-0.94 in.) from float arm. Adjust if necessary by bending float arm actuating tab.

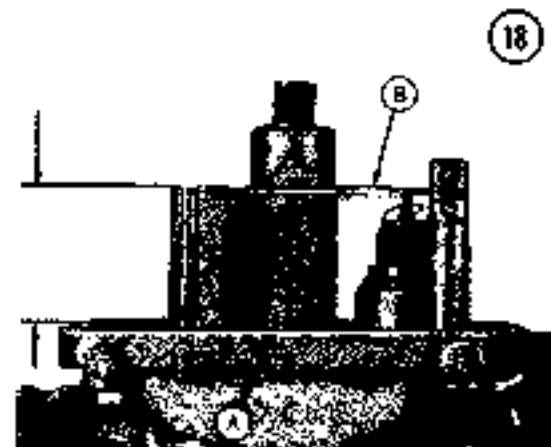

A. Mixing chamber B. Float arm

6. Install needle jet. Make sure notch on needle jet is correctly aligned with pin on bore of mixing chamber (**Figure 19**). Install ring over needle jet hole (recess in ring next to bore) and screw main jet into needle jet.

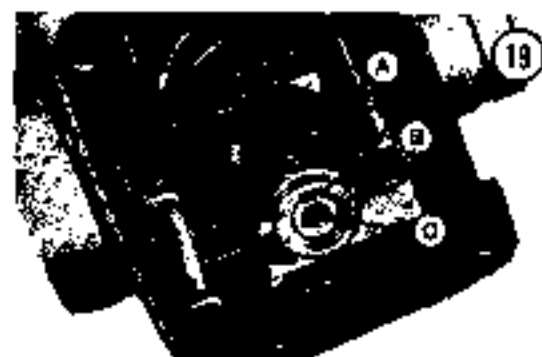

A. Pin B. Notch C. Needle jet

7. Slide floats over float pin. Pins on float must be down and point to inside of float chamber as shown in **Figure 20**.
8. Install float chamber in mixing chamber body and secure with 4 screws.

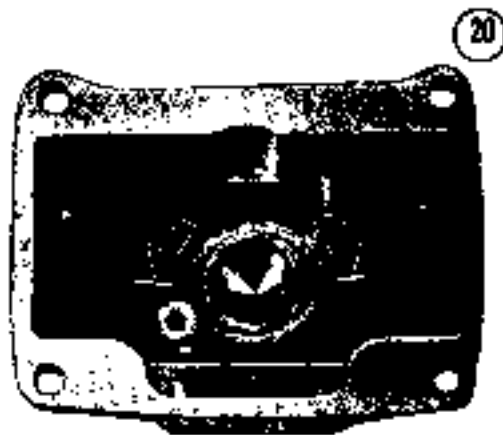

9. Slide air screw spring over air screw and install air screw gently.

CAUTION

Do not force air screw or seat damage may occur.

10. Install throttle stop screw with spring. Install screw until it is just flush with inside of bore.

AIR INTAKE SILENCERS

Air intake silencers are installed on snowmobiles to quiet the sound of rushing air and to catch fuel that spits back out of the carburetor throat. Refer to Figures 21, 22, 23, and 24 for typical examples.

The silencer is not intended to filter incoming air. Operate snowmobiles only in clean, snow-covered areas.

CAUTION

Do not operate snowmobile with silencer removed. Loss of power and engine damage may result due to a leaner mixture.

Service of air intake silencers is limited to removal and cleaning of components.

FUEL TANK

Refer to Figures 21, 22, 23, and 24 for typical fuel tank installations.

NOTE: On 1970 Olympiques and some TNT models, the fuel tank is built in. Service is limited to draining tank and removing fuel lines and fuel line adaptor.



Removal/Installation

1. Siphon fuel from tank into a suitable container.
2. Disconnect fuel lines from fuel line adaptor. Tag lines to aid reconnection.
3. Loosen clamp and unscrew fuel line adaptor from tank.
4. Remove bolts and nuts securing tank mounting straps (Figure 25) and remove tank.
5. Installation is the reverse of these steps. Install fuel line adaptor so fuel nipples point toward rear of machine and tighten clamp.

FUEL FILTER

Service of fuel filter (Figure 26) is limited to cleaning of screen type filter or replacement of paper element filters.

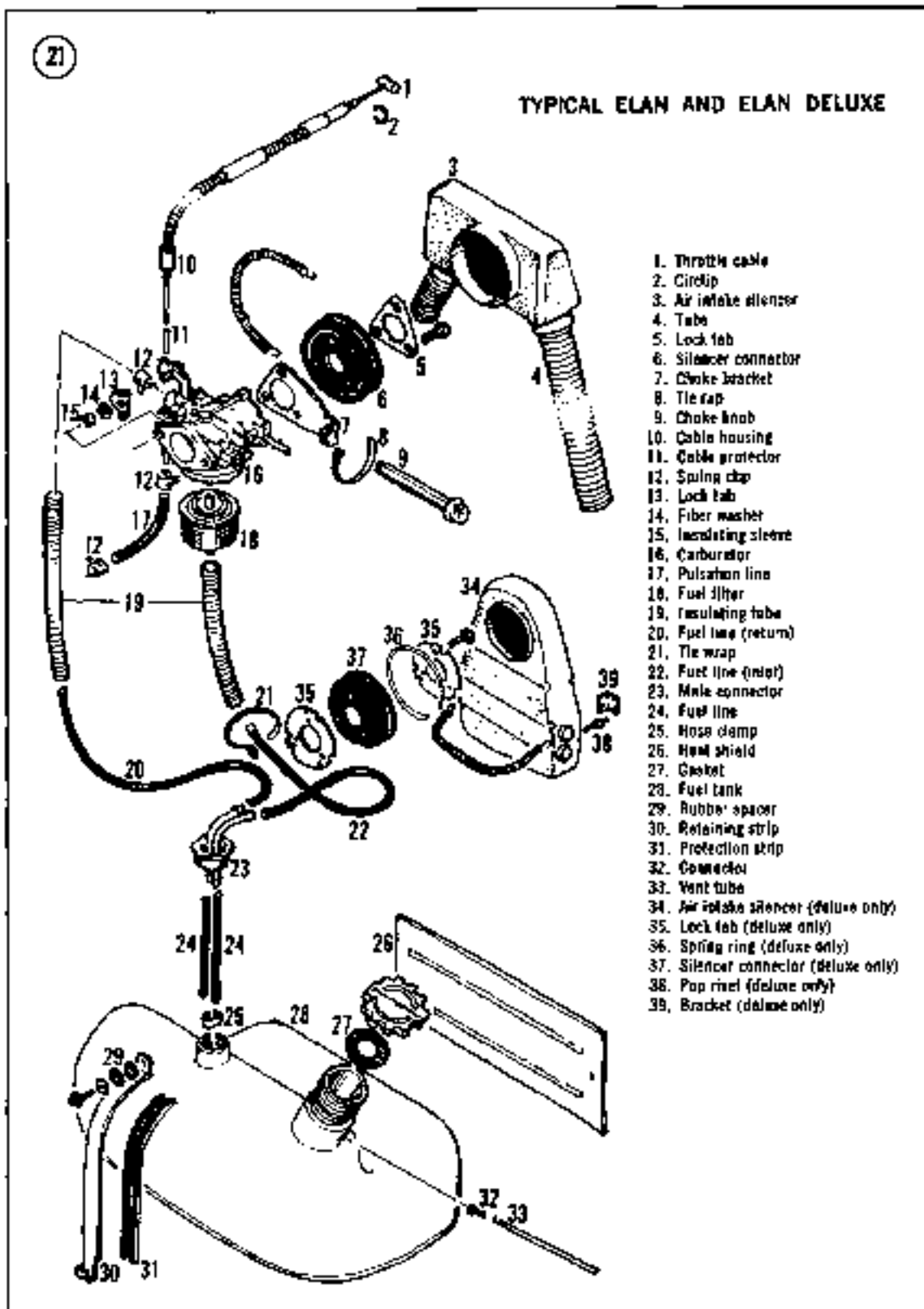

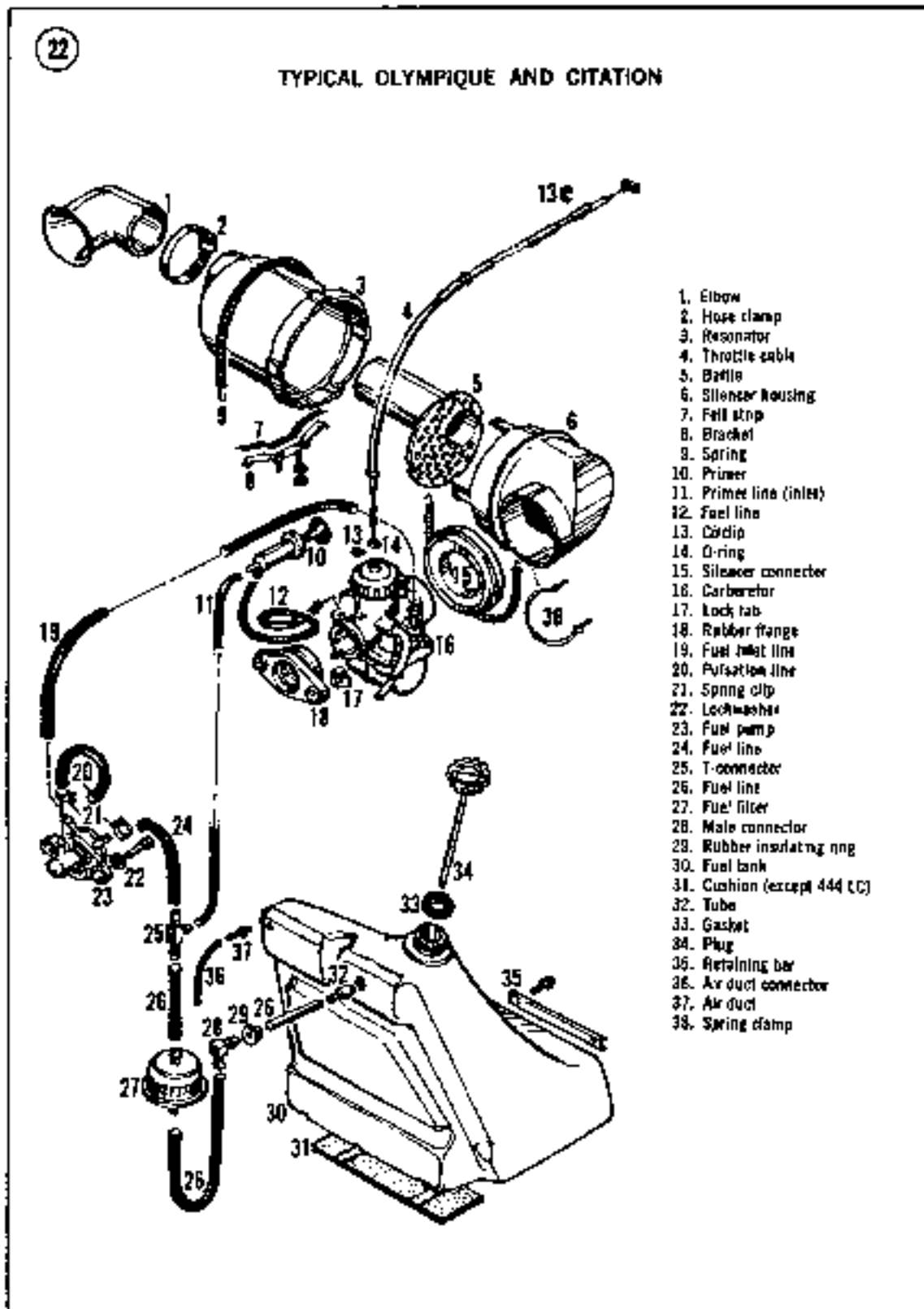

23

TYPICAL T'NT AND EVEREST

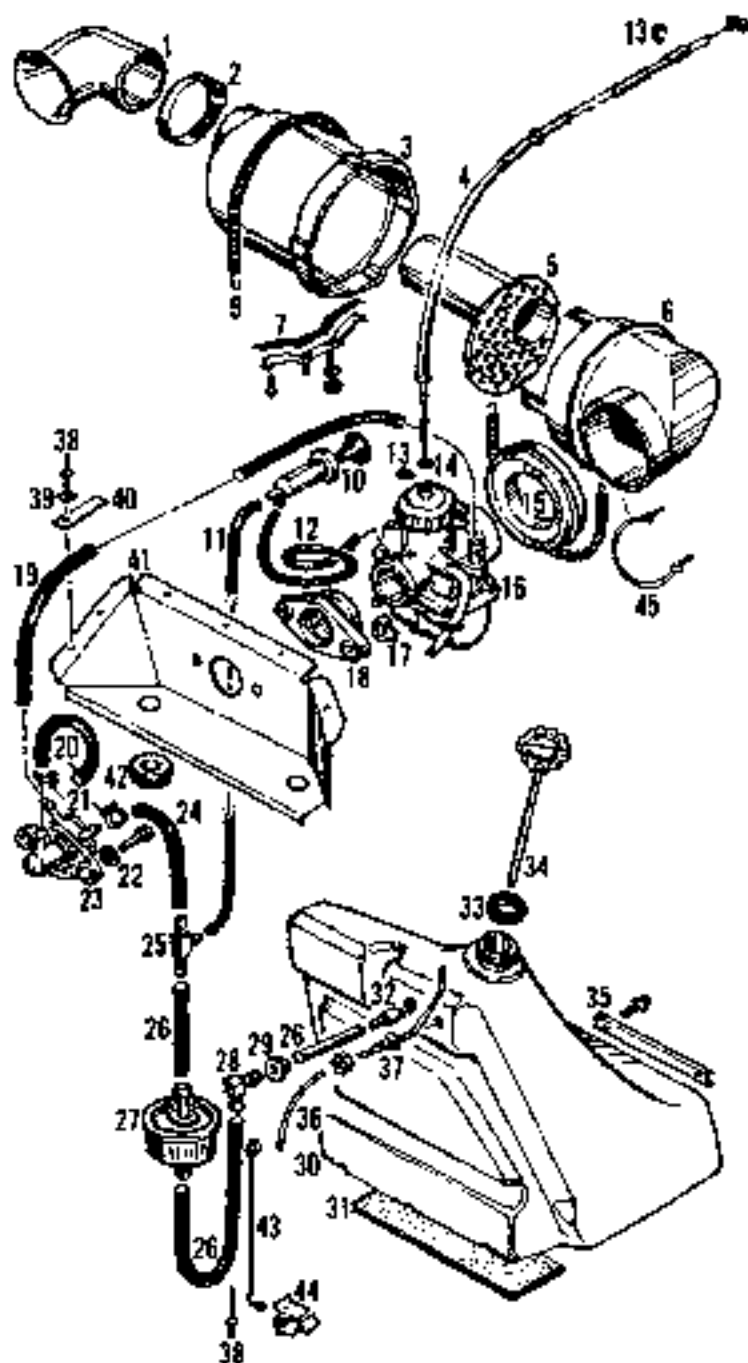

1. Elbow
2. Hose clamp
3. Resonator
4. Throttle cable
5. Baffle
6. Silencer housing
7. Felt strip
8. Bracket
9. Spring
10. Primer
11. Primer line (inlet)
12. Fuel line
13. Caplip
14. O-ring
15. Silencer connector
16. Carburetor
17. Lock tab
18. Rubber flange
19. Fuel inlet line
20. Fuel line
21. Spring clip
22. Lockwasher
23. Fuel pump
24. Fuel line
25. T-connector
26. Fuel line
27. Fuel filter
28. Male connector
29. Rubber insulating ring
30. Fuel tank
31. Cushion (except 444 LC)
32. Tube
33. Gasket
34. Plug
35. Retaining bar
36. Air duct
37. Air duct connector
38. Pop rivet (T'NT F/A)
39. Washer (T'NT F/A)
40. Rubber gasket (T'NT F/A)
41. Deflector (T'NT F/A)
42. Insulating ring (T'NT F/A)
43. Air duct support (except 444 LC)
44. Clip (air duct, 444 LC)
45. Spring clamp

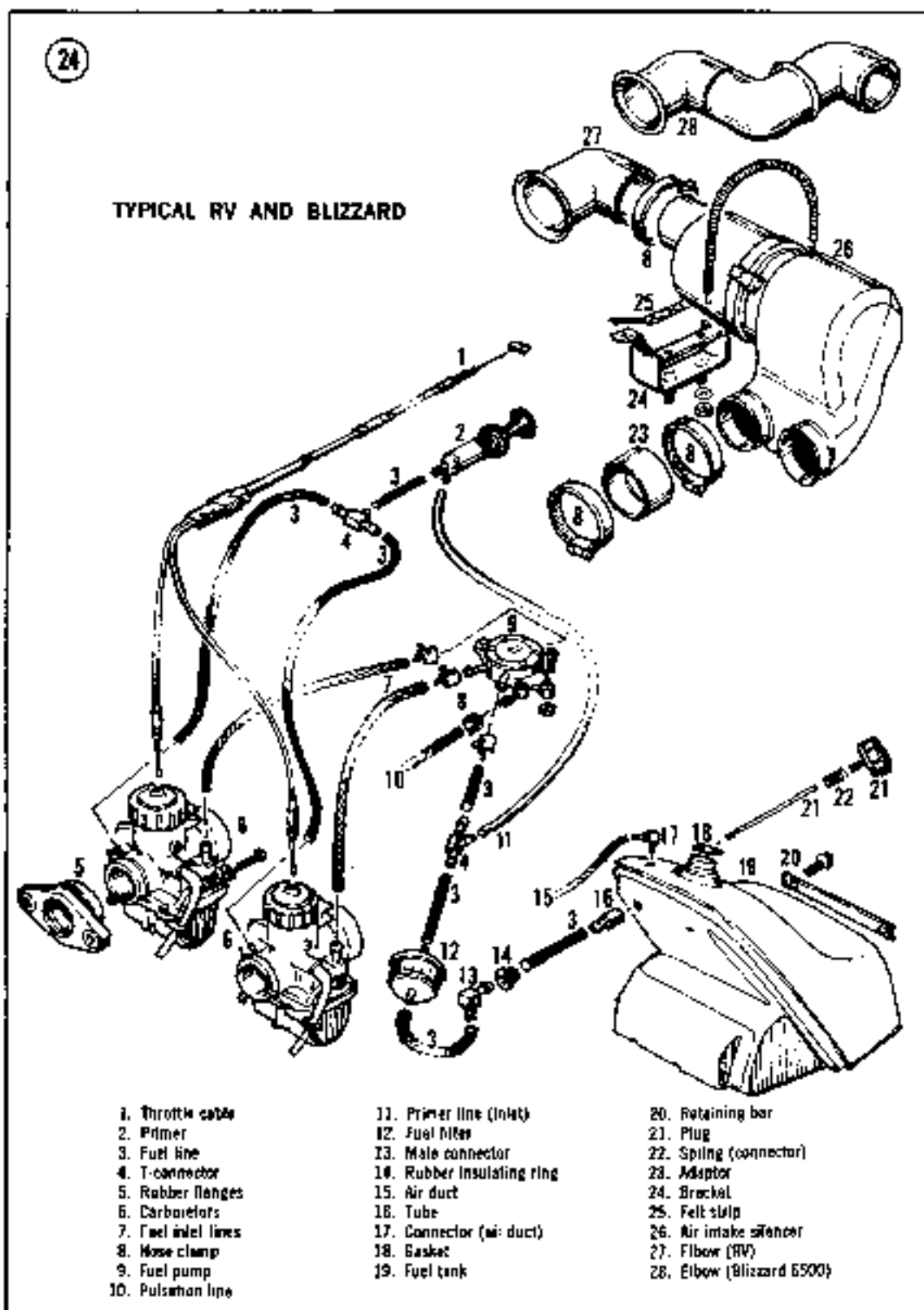

To clean screen type filter, disassemble and flush with gasoline or solvent and blow dry with compressed air.

Paper element filters should be replaced annually or when contamination builds up at the base of the element.

FUEL PUMP

To check fuel pump (Figure 27) operation, disconnect fuel line from pump to carburetor at the carburetor. Make sure ignition is off and pull recoil starter and check for fuel flow at fuel line. If fuel flow from pump is unsatisfactory, replace pump. Refer to Figure 28 for an exploded view of a typical fuel pump.

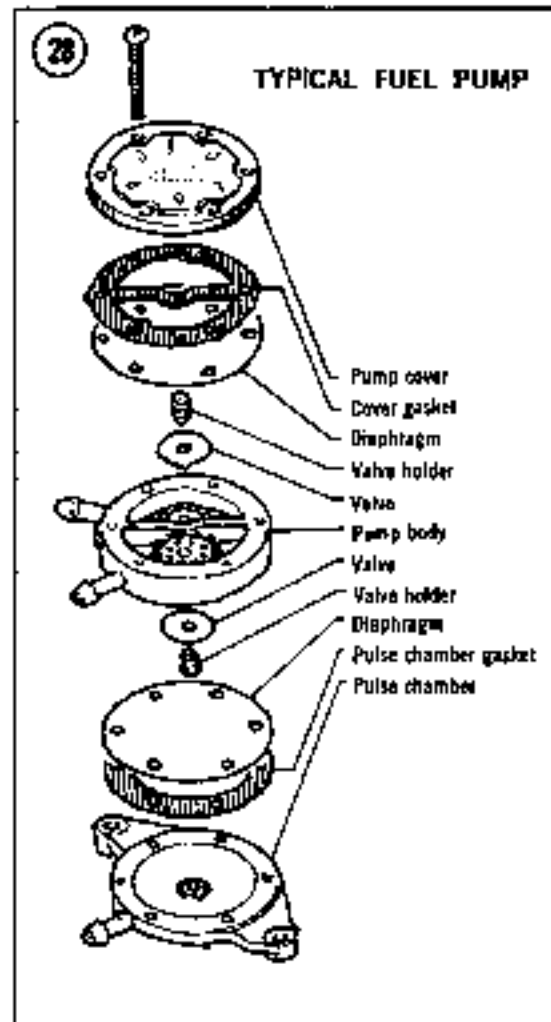

Table 1 TILLOTSON CARBURETOR SPECIFICATIONS

Model	Carburetor	Low Speed Adjustment (Turns)**	High Speed Adjustment (Turns)**	Idle Speed (rpm)
Elan				
250, 250 E (1971, 1972, early 1973)	HR-73A	$\frac{3}{4}$	$1\frac{1}{4}$ ⊕	*
250 (late 1973-1975)	HR-133A	$\frac{3}{4}$	Fixed	*
292 SS (1972)	HD-22B	$\frac{3}{4}$	$1\frac{1}{4}$	*
250 T (1973)	HR-136A	$\frac{3}{4}$	Fixed	*
250 T, 250 Deluxe (1974)	HR-155A	1	Fixed	*
250 Deluxe (1975)	HR-165A	1	Fixed	*
250 (1976)	HR-173A	1	Fixed	*
250 SS (1973)	HR-143A (2)	$\frac{3}{4}$	Fixed	*
294 SS (1974)	HR-161A	$\frac{3}{4}$	Fixed	*
300 SS (1975)	HR-166A	$\frac{3}{4}$	Fixed	*
250 SS (1976)	HR-172A	1	Fixed	1,500-1,800
250 (1978-1979)	HR-173A	1	Fixed	1,800-2,000
250 Deluxe (1978-1979)	HR-172A	1	Fixed	1,800-2,200
Olympique				
300 (1971-early 1973)	HR-74A	$\frac{3}{4}$	$1\frac{1}{4}$	*
300 (late 1973-1974)	HR-132A	$\frac{3}{4}$	1	*
300 (1975 and 1976 twin)	HR-169A	1	Fixed	1,500-1,800
300 (1976 single)	HR-174A	1	Fixed	1,200-1,500
335 (1970)	HR-176	$\frac{3}{4}$	$1\frac{1}{4}$	*
335 (1971-1973)	HR-75A	$\frac{3}{4}$ ⊕	$1\frac{1}{4}$ ⊕	*
340 (1973-1974)	HR-131A	$\frac{3}{4}$	Fixed	*
340 (1975-1976)	HR-170A, B	1	Fixed	1,500-1,800
399 (1970)	HR-16B	$\frac{3}{4}$	$1\frac{1}{4}$	*
399 (1971-1972)	HR-76A	$\frac{3}{4}$	$1\frac{1}{4}$	*
400 (early 1973)	HR-76A	1	$1\frac{1}{4}$	*
400 (late 1973-1974)	HR-134A	$\frac{3}{4}$	Fixed	*
440 (1973-1974)	HR-135A	$\frac{3}{4}$	Fixed	*
440 plus (1976)	HR-176A	1	Fixed	1,500-1,800
TNT				
292, 340 (1970, 1971, and 1972-292)	HD-22A, B	$\frac{3}{4}$	$1\frac{1}{4}$	*
340 (1972)	HD-98A	$1\frac{1}{8}$	1	*
294 (1973)	HR-137A (2)	$\frac{3}{4}$	Fixed	*
340 (1973)	HD-107A	$\frac{7}{8}$	Fixed	*
300 (1974)	HR-164A	1	1	*
340 (1974-1975)	HD-134A	1	1	*
340 (1976)	HD-148A	1	1	1,500-1,800
399 (1970)	HD-21A	$\frac{3}{4}$	$1\frac{1}{4}$	*
440 (1971)	HD-73A	$\frac{3}{4}$	$1\frac{1}{4}$	*

(continued)

Table 1 TILLOTSON CARBURETOR SPECIFICATIONS (continued)

Model	Carburetor	Low Speed Adjustment (Turns)**	High Speed Adjustment (Turns)**	Idle Speed (rpm)
TNT (con't.)				
440 (1972)	HD 83A	1 1/4	1 1/4	*
440 (1973)	HD-109A	1	1	*
440 and Everest (1974-1975)	HD-138A	1	1	*
440 and Everest (1976)	HD 147A	1	1	1,500-1,800
400 F/A (1972)	HD 104A (2)	3/4	1 1/4	*
340 F/A (1973-1974)	HR 149A (2)	1	1 1/8	*
400 F/A (1973-1974)	HD 123A (2)	1	5/8	*
340 F/A (1975)	HR-168A (2)	1	1 1/8	*
440 F/A (1974)	HRM 3A (2)	1	1 1/4	*
440 F/A (1975)	HRM-5A (2)	1	1	*
* Unless otherwise specified, idle speed is 1,800-2,200 rpm.				
** Tolerance for all adjustments is +3/8-0 turn.				
Ⓢ Fixed jet on later 1973 models.				
Ⓣ On 1973 models turn low-speed needle 3/4 and high-speed needle 1 1/4.				

Table 2 MIKUNI CARBURETOR SPECIFICATIONS

Model	Carburetor	E-ring Position (From Top)	Air Screw Turns (± 1/4 Turn)
TNT R/V 245 (1975)	VM 34-72	2	1
TNT 340-340E kit (1976)	VM 34-109	3	1
TNT 440-440E kit (1976)	VM 34-105	2	1
Olympique 340-340E kit (1976)	VM 34-104	3	1
Olympique 300-300E kit (1976)	VM 34-103	3	1
TNT R/V 250 (1976)	VM 34-92	2	1
TNT R/V 340 (1976)	VM 34-94	2	1
Olympique 440 plus kit (1976)	VM 32-117	3	1 1/2
Olympique 300 (twin) 1977-1978	VM 30-90	3	1 1/2
Olympique 340-340E (1977-1979)	VM 30-91	3	1 1/2
Everest 340-340E kit (1977-1979)	VM 30-98	3	1 1/2
Olympique 440 (1977)	VM 32-113	4	1 1/2
TNT 340 F/A (1977-1978)	VM 34-118	3	1
TNT 440 F/A (1977)	VM 36-53	2	1
TNT 440 (1977)	VM 34-110	3	1 1/2
R/V 340 (1977-1978)	VM 34-105	4	1
Everest 440-440E (1977)	VM 34-110	3	1 1/2
Everest 440 LC (1977)	VM 34-150	4	1
Citation 300 (1978)	VM 30-94	3	1 1/2
Citation 300 (1979)	VM 30-104	3	1 1/2
Everest 440-440E (1978)	VM 34-165	3	2
TNT 440 F/C (1978)	VM 34-165	3	2
Everest 441 LC	VM 34-150	4	1 1/2
Blizzard 6500	VM 34-184	4	1 1/2
Blizzard 9500	VM 36-78	4	1
Blizzard 5500	VM 34-203	3	1 1/2
Blizzard 7500 and Cross Country	VM 34-199	2	1 1/2

CHAPTER SIX

ELECTRICAL SYSTEM

The electrical system on Ski-Doo snowmobiles consists of an ignition system, lighting system, and an optional electric starting system.

Two types of ignition systems are used: a breaker point magneto and capacitive discharge ignition (CDI). Refer to Figures 1 and 2 for a typical example of each system.

The lighting system consists of a headlight, brake/taillight, and instrument lights.

The electric starting system is an optional package consisting of a battery, a starter with solenoid, and charging components.

This chapter includes testing and repair of some components of the ignition, lighting, and charging systems. Many of the testing and repair tasks referenced in this chapter require special testing equipment and tools. These tasks are best accomplished by an authorized dealer or competent auto electric shop.

Refer to Chapter Two for magneto breaker point and timing adjustments.

CDI SYSTEM

The capacitor discharge ignition system supplies high voltage to spark plugs without the use of breaker points as in a conventional magneto ignition system.

The entire system electronic components are not repairable and must be replaced if found defective.

If ignition system malfunctions are experienced, perform the following troubleshooting procedure. Refer any additional testing and repairs to an authorized dealer.

CDI Troubleshooting

1. Check spark plugs (Chapter Two) and spark plug wires and replace if defective.
2. Disconnect junction block connected to engine kill button.
3. Start engine. If engine does not miss, replace kill button. If engine continues to miss or will not start, continue procedure.
4. On models equipped with trigger box, perform the following:
 - a. Disconnect violet and black/violet wires from timing box.
 - b. Connect ohmmeter between wires. Ohmmeter should indicate 55-60 ohms. If resistance is not as specified, magneto side cylinder pick-up coil is defective. Replace armature plate.
 - c. Disconnect black/yellow and violet/yellow wires from timing box.
 - d. Connect ohmmeter between wires. Ohmmeter should indicate 55-60 ohms. If resistance is not as specified, pro side cylinder pick-up coil is defective. Replace armature plate.

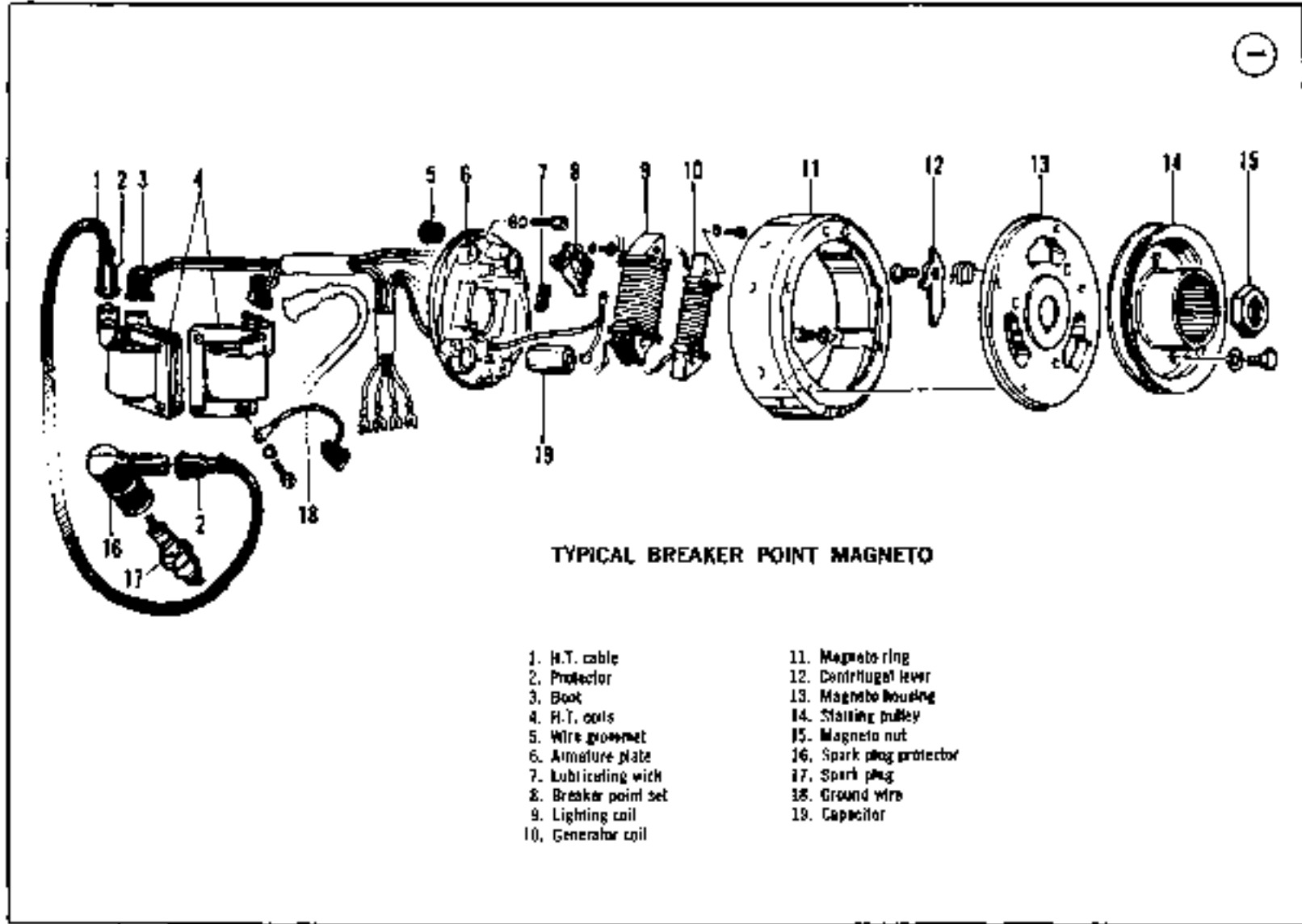

TYPICAL BREAKER POINT MAGNETO

- | | |
|----------------------|--------------------------|
| 1. H.T. cable | 11. Magneto ring |
| 2. Protector | 12. Centrifugal lever |
| 3. Book | 13. Magneto housing |
| 4. H.T. coils | 14. Stalling pulley |
| 5. Wire grommet | 15. Magneto nut |
| 6. Armature plate | 16. Spark plug protector |
| 7. Lubricating wick | 17. Spark plug |
| 8. Breaker point set | 18. Ground wire |
| 9. Lighting coil | 19. Capacitor |
| 10. Generator coil | |

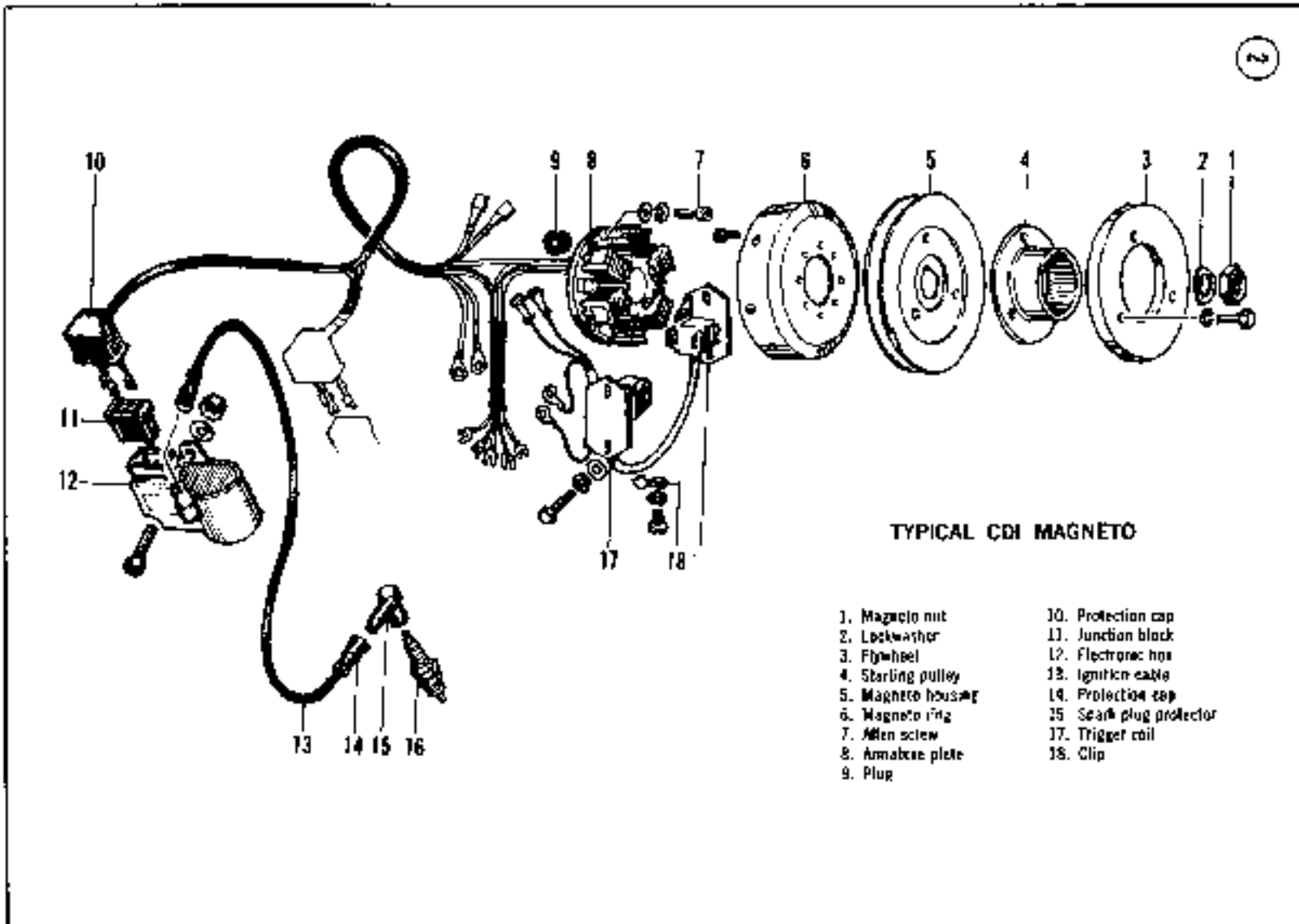

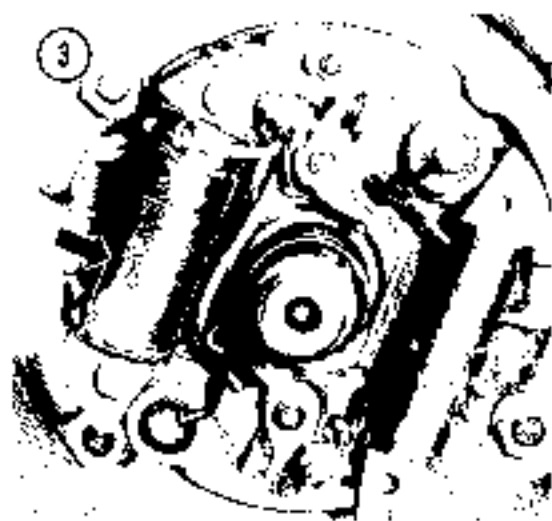

- e. If either pick-up coil is defective, remove armature plate assembly from engine as described in Chapter Four.
- f. If both pick-up coils check out good, proceed to Step 6.
5. On models without trigger box, perform the following:
 - a. Disconnect junction block from electronic box.
 - b. Connect ohmmeter between violet/yellow wire in junction block (not electronic box) and ground. Ohmmeter should indicate 55-60 ohms. If resistance is not as specified, right side cylinder pick-up coil is defective. Replace armature plate.
 - c. Connect ohmmeter between violet wire in junction block and ground. Ohmmeter should indicate 55-60 ohms. If resistance is not as specified, magneto side cylinder pick-up coil is defective. Replace armature plate.
 - d. If pick-up coils check out as specified and engine misfires on one cylinder, replace electronic box. If either pick-up coil is defective, remove armature plate assembly as outlined in Chapter Four.
 - e. If engine will not fire on either side, perform the next step.
6. If pick-up coils check out as specified, perform the following:
 - a. Disconnect junction block from electronic box if not already disconnected.

- b. Connect ohmmeter between ground and red wire in junction block (not on electronic box). Ohmmeter should indicate 325-365 ohms.
- c. If resistance is not as specified, remove armature plate as outlined in Chapter Four and have an authorized dealer replace ignition generator coil.
- d. If resistance is within tolerance, replace electronic box.
- e. Reconnect all junction blocks.

MAGNETO IGNITION

The testing of ignition generating coil, condenser, brake light coil, and ignition coils requires expensive sensitive test equipment. If a malfunction is suspected in any of these components, have it tested by an authorized dealer or competent auto electric shop. They have the equipment and expertise for the task.

If malfunctions exist in ignition generating coil or condenser, remove armature plate as outlined in Chapter Four.

Refer to Chapter Two for breaker point and timing adjustments.

LIGHTING SYSTEM

The lighting system consists of a headlight and brake/tailight unit, instrument lights and an AC (alternating current) generating device. Switches control all lighting circuits. The lighting coil on the magneto armature plate generates AC current.

On models equipped with an electric starter, AC is converted (rectified) to DC (direct current) by a rectifier and then used to keep the battery charged.

Lighting Coil

Testing of lighting coil (Figure 3) requires expensive sensitive test equipment. If a lighting coil malfunction is suspected, remove magneto armature plate as outlined in Chapter Four and refer testing or repair to an authorized dealer.

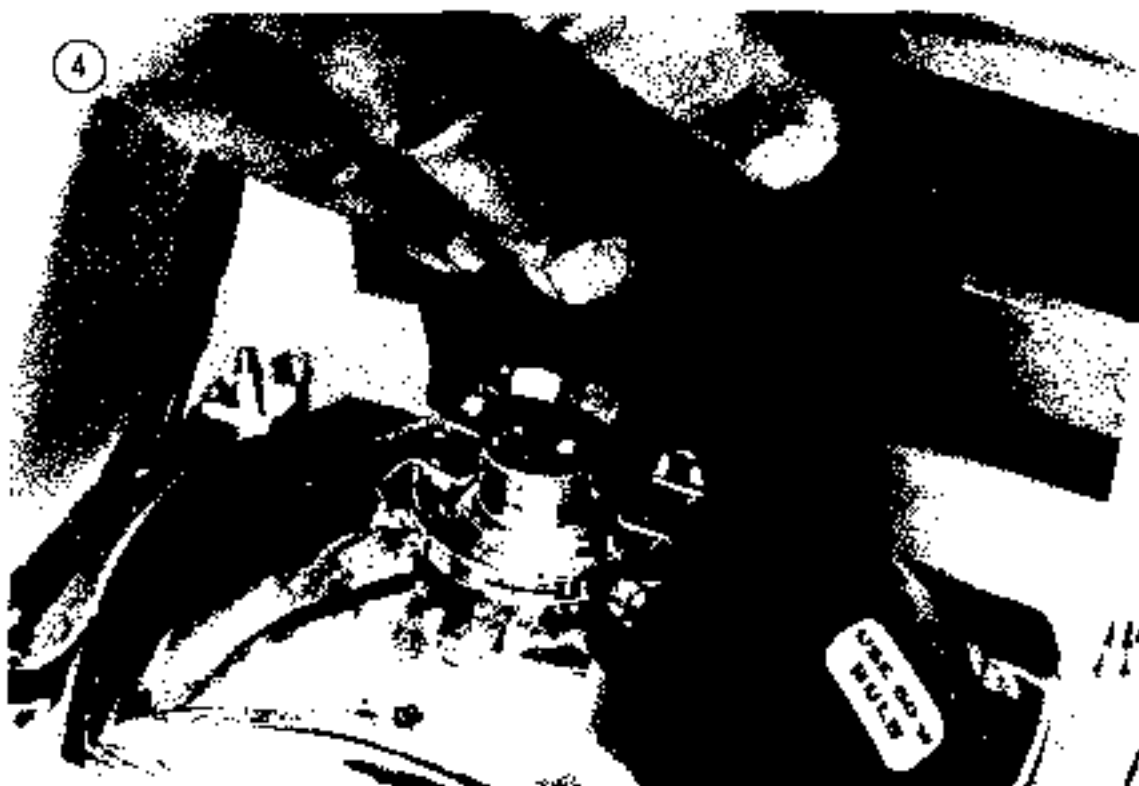

Light Switch Test

1. Remove wire connectors from light switch.
2. Use an ohmmeter or flashlight continuity tester and test operation of switch in OFF and ON positions.
3. Replace switch if defective. Connect wires to switch.

Headlight Replacement

Lift retaining clips securing bulb socket (Figure 4). Twist and pull out bulb. Ensure that new bulb is of the same wattage rating as the old one.

Brake/Tailight Bulb Replacement

1. Remove screws (Figure 5) securing light lens and remove lens. On models without lens retaining screws, unsnap lens.
2. Push in and rotate bulb counterclockwise to remove (Figure 6).
3. Install new bulb making sure alignment pins on bulb are properly aligned.
4. Install lens and secure with retaining screws.



Headlight Adjustment

1. Position snowmobile on a flat surface with headlight 25 ft. (7.6m) from a vertical surface (Figure 7).
2. Turn on high beam. Light adjustment is correct if beam center is equal with horizontal beam line. Maximum horizontal deviation from center is 2 in. (5 cm). Maximum vertical deviation is 1 in. (2.5 cm).
3. If light alignment is incorrect, remove headlight ring and adjust upper and lower screws until beam is within specified tolerance.

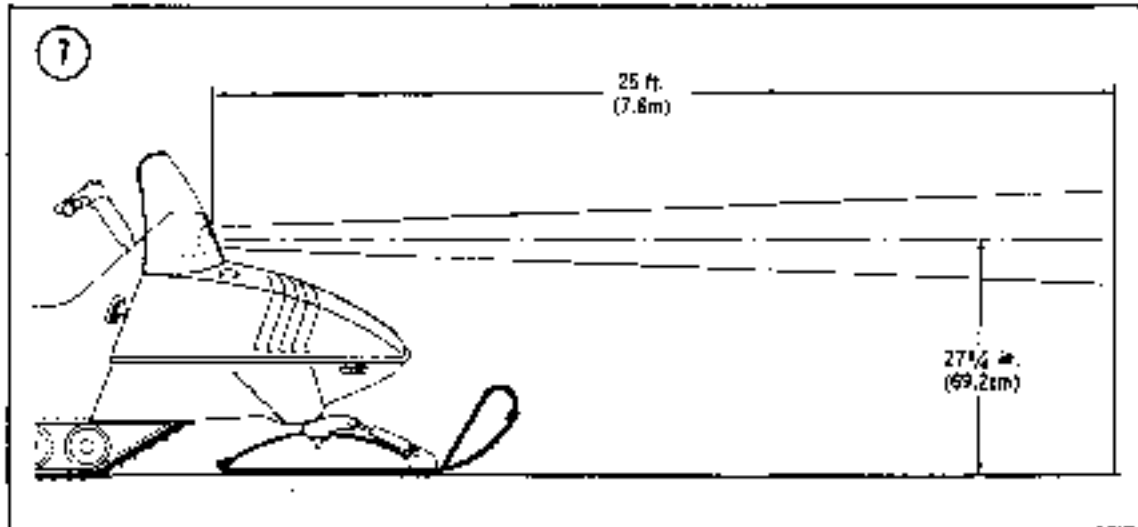
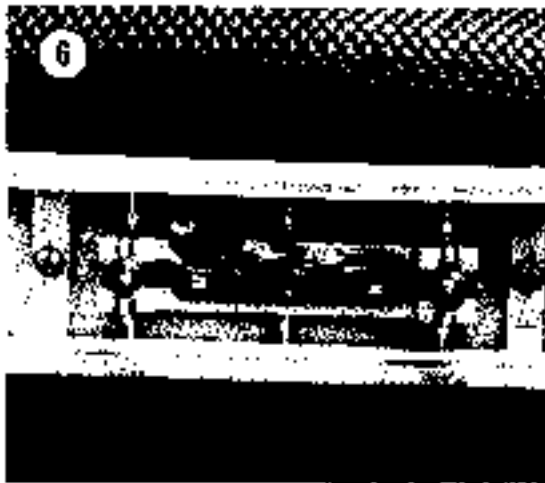

NOTE: On older models it may be necessary to use small wedges behind headlight ring to obtain desired deflection.

ELECTRIC STARTING SYSTEM

The electric starting system consists of a 12-volt battery, starter motor with solenoid and a rectifier.

The starter solenoid acts as a relay to route battery current to the starter as well as mechanically engage the starter drive. The starter drive engages with a ring gear on the engine to turn the engine over.

The battery is kept charged by current supplied by the lighting coil which is rectified to dc (direct current) by the rectifier.

Starter and Solenoid Removal/Installation

Starter testing and repair requires special tools. It is recommended that all starter service and repair be referred to an authorized dealer or competent auto electric shop.

1. Disconnect battery ground cable (Figure 8).
2. Disconnect battery cable and switch wires from solenoid (Figure 9).
3. Remove capscrews and washers securing starter bracket to crankcase (Figure 10).
4. Remove nuts and washers securing starter bracket to starter.

- Remove nuts and washers securing starter to engine. Remove starter and solenoid with starter bracket.
- Installation is the reverse of these steps.

Battery Removal/Installation

- Disconnect negative (-) cable (Figure 8). Remove rubber boot and disconnect positive (+) cable.
- Loosen hold-down bolts (Figure 11) and unhook bolts from battery box. Remove hold-down clamp.
- Disconnect vent tube from battery. Carefully lift battery out of battery box.
- Installation is the reverse of these steps. Keep the following points in mind:

CAUTION

Be sure battery connections are correct or serious damage to electrical components will occur.

- Be sure exterior of battery and terminals are clean and free from corrosion.
- Connect positive (+) cable to battery first.

Battery Cleaning and Service

Electrolyte level in the battery should be checked periodically, especially during periods of regular operation. Use only distilled water and top off battery to bottom of ring (filler neck) so the tops of the plates are covered. *Do not overfill.*

Battery corrosion is a normal reaction; however, it should be cleaned off periodically to keep battery deterioration to a minimum.

Remove battery and wire brush terminals and cable ends. Wash terminals and exterior of battery with about a 4:1 solution of warm water and baking soda.

CAUTION

Do not allow any baking soda solution to enter battery cells or serious battery damage may result.

Wash battery box and hold-down bolts with baking soda solution. Rinse all parts in clear water and wipe dry.

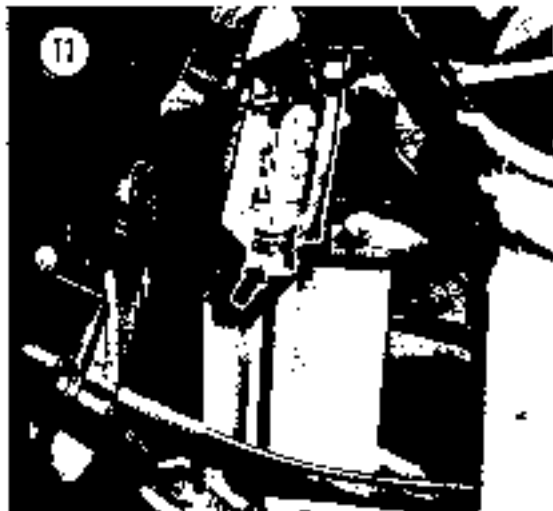
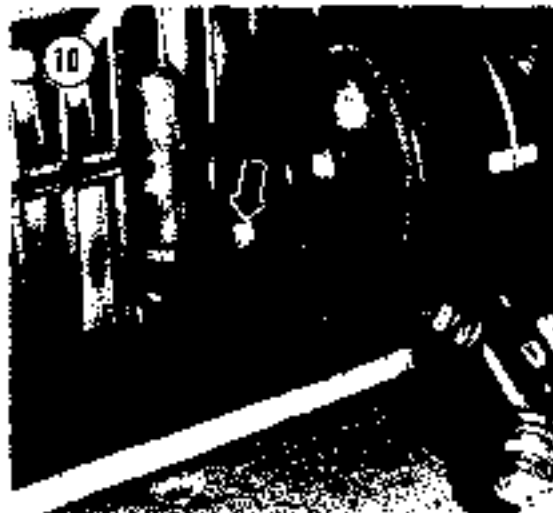
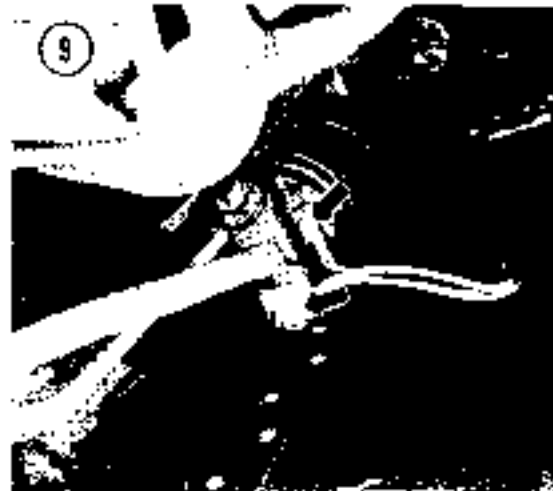

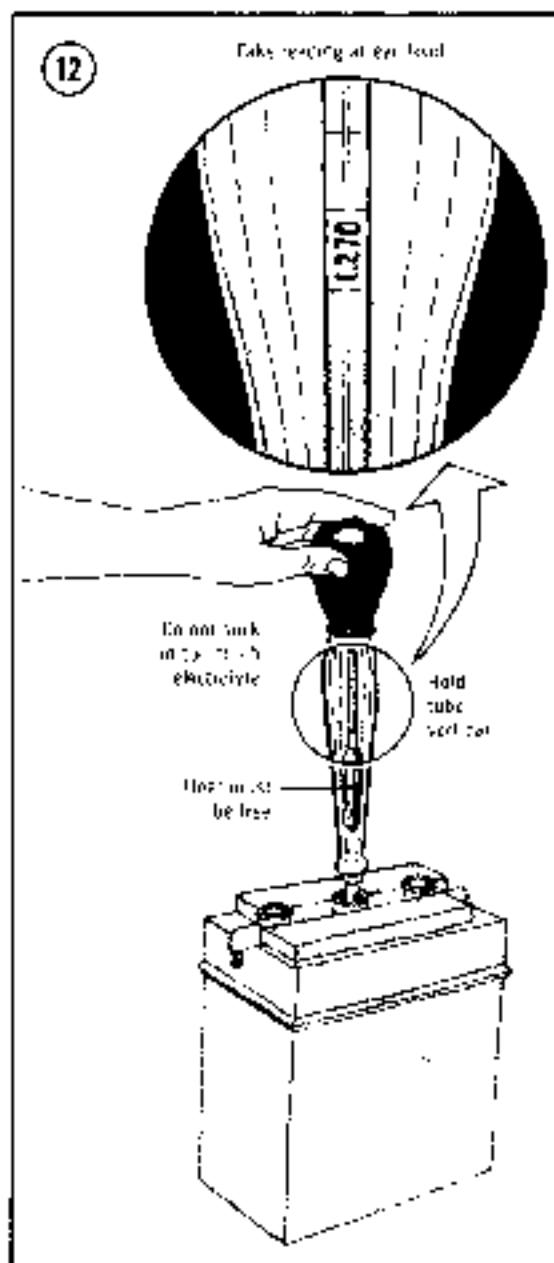

In freezing weather, never add water to a battery unless the machine will be operated for a period of time to mix electrolyte and water.

CAUTION

Keep battery fully charged. A discharged battery will freeze causing the battery case to break.

Remove the battery from the machine during extended non-use periods and keep battery fully

charged. Perform periodic specific gravity tests with a hydrometer to determine the level of charge and how long charge stays up before it starts to deteriorate.

Battery Specific Gravity Test

Determine the state of charge of the battery with a hydrometer. To use this instrument, place the suction tube (Figure 12) into the filler opening and draw in just enough electrolyte to lift the float. Hold the instrument in a vertical position and take the reading at eye level.

Specific gravity of electrolyte varies with temperature, so it is necessary to apply a temperature correction to the reading you obtain. For each 10° that the battery temperature exceeds 80°F, add 0.004 to the indicated specific gravity. Subtract 0.004 from the indicated value for each 10° that the battery temperature is below 80°F.

WARNING

Do not smoke or permit any open flame in any area where batteries are being charged. Highly explosive hydrogen gas is formed during the charging process.

The specific gravity of a fully charged battery is 1.260. If the specific gravity is below 1.220, recharge the battery (Figure 13).

Starter Test

If starter fails to crank engine or cranks engine very slowly, perform the following:

1. Inspect cranking circuit wiring for loose or badly corroded connections or damaged wiring.
2. Perform *Battery Specific Gravity Test* to be certain battery is charged and not defective.
3. Crank engine with recoil starter to make sure engine turns freely and is not seized.

NOTE: Remove spark plug wires. The following bypasses the ignition switch.

4. If starter still will not crank engine, place a heavy jumper lead from positive (+) battery terminal directly to starter terminal (Figure 14). This bypasses ignition switch and starter solenoid. If starter motor operates, then one of these items is defective. If starter motor will not operate, starter is defective.

Starter Solenoid Test

1. The starter solenoid is a sealed magnetic switch and cannot be repaired. If defective, it must be replaced.
2. Remove and insulate cable from starter terminal. Connect test light across 2 large terminals of starter solenoid.
3. With a jumper lead, connect positive (+) battery post to small terminal on solenoid. Solenoid plunger should snap in, light the test lamp, and hold until the jumper is removed. If not, solenoid is defective.

Rectifier Test

1. Disconnect 4 connectors from rectifier. A diode exists between each of the 4 terminals in the rectifier. Test the 4 diodes one at a time by connecting a test light to 2 adjacent terminals.
2. Test with leads on 2 top terminals, 2 bottom terminals, 2 left terminals, and 2 right terminals. Reverse terminal contacts in each test se-

up. Do not test terminals in a diagonal pattern.

3. With leads connected one way, test light should light. With leads reversed, a high resistance or open condition should be indicated. Repeat test for the other 3 diodes. Replace if defective.

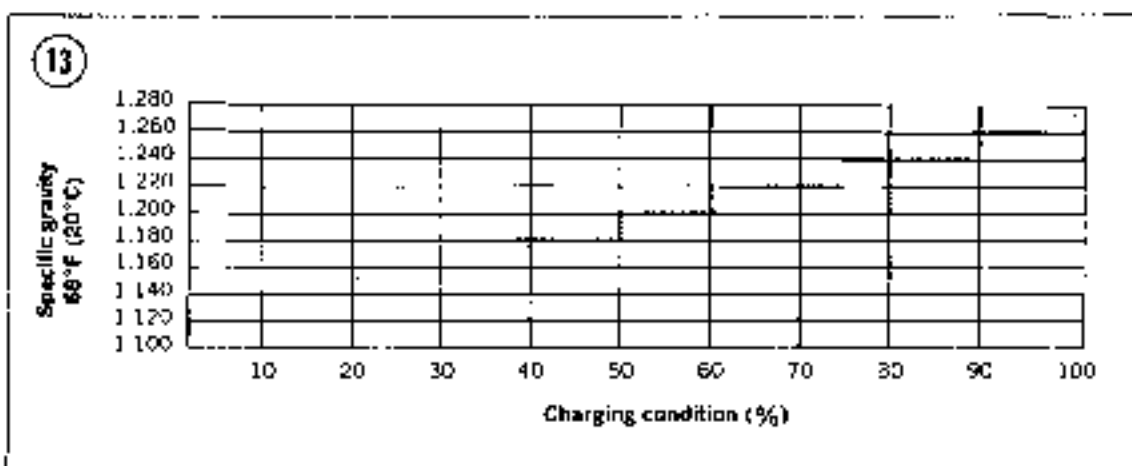

CHAPTER SEVEN

POWER TRAIN

The power train consists of a drive belt, drive and driven pulleys, drive chain and sprockets with chaincase, and a brake assembly.

Three types of brake systems are used: pivot, drum, and disc. Disc brakes are either mechanically adjusted or self-adjusting. A hydraulic disc brake is installed on the 1973 T'NT F/A model. Pivot and drum brakes are mechanically adjusted.

Some procedures in this chapter require the use of special tools for removal and repair work. If such tools are not available and substitutes cannot be locally fabricated, refer the removal and repair work to an authorized dealer.

DRIVE BELT

The drive belt transmits power from the drive pulley to the driven pulley. Refer to Table 1 for drive belt model application. Drive belt should be replaced when its width is reduced by approximately $\frac{1}{8}$ in. (3.0mm). Always install the drive belt specified for your type of machine. Drive belts are not interchangeable between different models even though belt width may be the same.

Removal/Installation

1. Tilt cab and remove pulley guard (Figure 1).
2. Twist and push sliding half of driven pulley to open pulley.

Table 1 DRIVE BELT APPLICATION

Model	Belt Width
Elan (all models)	1 $\frac{1}{2}$ in.
Olympic Le Plus (1970)	1 $\frac{1}{2}$ in.
All 1975 and earlier models except 1975 T'NT RM 250	1 $\frac{1}{2}$ in.
T'NT RM 250	1 $\frac{1}{2}$ in.
All other models	1 $\frac{3}{8}$ in.

Note: Replace belt when width is reduced by $\frac{1}{8}$ in. (3mm)



3. Hold pulley in open position and slip drive belt off of driven pulley then drive pulley (Figure 2).



CAUTION

Do not use belt as test pulley or belt work at pulley may be damaged.

4. Installation is the reverse of these steps. Check drive belt tension.

Drive Belt Tension Adjustment

Drive belt tension must be correct or improper drive and abnormal belt wear may result.

Check tension on all machines with a drive pulley *without* bearings on the shaft.

1. Position a ruler on drive belt for a reference.
2. Using a stick and fish scale apply 15 lb. (6.8 kg) of pressure at center of belt. Belt should deflect 1%, ± 1 in. (30-38mm).
3. If belt tension is incorrect, decrease or increase distance between pulleys. Recheck belt deflection.

DRIVE PULLEY

The following procedures require the use of special tools for removal, installation, and repair. If special tools or locally fabricated equivalents are not available, refer work to an authorized dealer. Refer to Table 2 for drive pulley model application.

CAUTION

Drive pulleys are matched to driver pulleys and engine. Do not use pulleys not designed for your particular machine or improper operation may result.

Pressure Lever and Roller Round Shaft Type Drive Pulley Removal-Installation

1. Remove drive belt.
2. To hold engine while removing retaining bolt, perform the following:
 - a. Remove spark plugs
 - b. Rotate crankshaft until piston (top piston for twin cylinder engines) is approximately 1 in. (25mm) BTDC.
 - c. Insert a length of rope such as recoil starter rope into spark plug hole (Figure 3).
 - d. Slowly rotate crankshaft counterclockwise until piston bears against rope.
3. Make sure alignment marks on pulley halves are visible. If not, make new marks.
4. Apply pressure to governor cup of pulley and remove retaining bolt (Figure 4).

NOTE: Pulley is spring loaded and may spring apart if pressure is not applied during bolt removal.

5. Gently remove sliding half of pulley with spring and spring seat (Figure 5).



Table 2 DRIVE PULLEY SPECIFICATIONS

Model	Pulley Type	Torque Method	Bolt Torque	
			Ft.-lb.	Mkg
Elan	1	A	37-54*	(5.1-7.5)
Olympique (1970-1974 and 1976 300 single)	2	A	37-54	(5.1-7.5)
Olympique (all 1975 and 1976 plus 440)	3	A	53-72	(11.5-12.7)
Olympique (1976 300 twin and 340)	3	B	58-68	(8.0-9.4)
Olympique (1978-1979 300T and 340)	3	B	58-68	(8.0-9.4)
Citation (1978-1979 300)	3	A	58-68	(8.0-9.4)
TNT FA 340, 400, 440	4	B	58-68	(8.0-9.4)
TNT and Everest**	3	A	83-92	(11.5-12.7)
TNT 245, 250, 340 R/V**	3	B	58-68	(8.0-9.4)
Everest 340, 440, 444 LC (1978-1979)	3	B	58-68	(8.0-9.4)
TNT 340 FA and 440 FC (1978)	3	B	58-68	(8.0-9.4)
R/V 340 (1978), Blizzard 5500i and 6100	3	B	58-68	(8.0-9.4)
Blizzard 7500 plus and 9500 plus	5	B	58-68	(8.0-9.4)
Pulley Type		Torque Method		
1 - Roller round shaft		A Torque to specifications, loosen and retorque to specification		
2 - Pressure lever		B Torque to specification. Start engine and alternate accelerate and brake. Stop engine and retorque to specification		
3 - Roller square shaft				
4 - High performance				
5 - Roller square shaft with 3 ramps				
* On 1975-250 Deluxe models, torque to 83-92 ft.-lb. (11.5-12.7 mkg)				
** Models equipped with "Duralon" bushings				



6. To remove fixed half of pulley from crankshaft, it is necessary to locally fabricate a removal tool. Perform the following:

- Cut a piece of pipe the approximate length of exposed pulley shaft. Pipe must be large enough to slide over pulley shaft.
- Drill a $\frac{1}{8}$ in. hole near end of pipe.
- Slide pipe over pulley shaft and install a $\frac{1}{8}$ in. bolt through pipe and hole in shaft end. Secure bolt with nut.

d. Use a pipe wrench on pipe and remove fixed half of drive pulley.

7. Refer all necessary inspection and repair to an authorized dealer.

8. Installation is the reverse of these steps. Keep the following points in mind:

- Pack inside pulley shaft with clutch lubricant available from an authorized dealer.
- Lightly oil retaining bolt threads.
- Ensure that pulley marks are aligned.
- Torque retaining bolt to 37-54 ft.-lb. (5.1-7.5 mkg). Loosen bolt and retorque to specified value.
- Perform *Pulley Alignment*.

Roller Square Shaft and High Performance Type Drive Pulley Removal/Installation

- Remove drive belt.
- On some models equipped with high per-

formance type pulley, it is necessary to raise engine from frame. Support engine with a wooden block between engine mount and frame cross support.

NOTE: Roller shaft pulleys are spring loaded. To avoid pulley springing apart during removal of retaining bolt, pressure must be applied and held against sliding half of pulley. On roller square shaft type pulleys, 1 or 2 clamps secured to outside rims of pulley halves can be used to hold spring tension (Figure 6). Exercise care when installing clamp(s) to avoid damaging or distorting pulley rims.

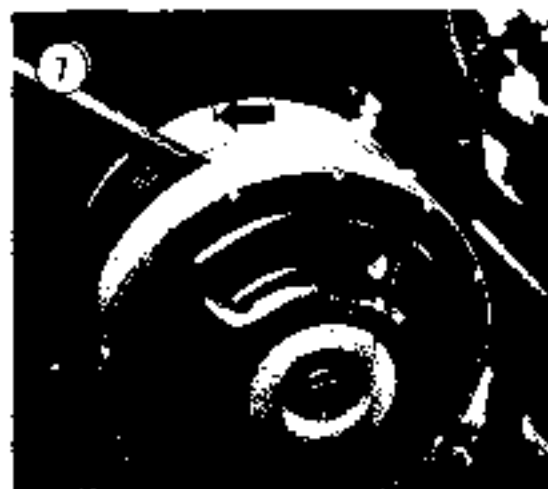

3. To hold engine while removing retaining bolt, perform the following:
 - a. Remove spark plug(s).
 - b. Rotate crankshaft until piston (PTO piston for twin cylinder engines) is approximately 1 in. (25mm) BTDC.
 - c. Insert a length of rope such as recoil starter rope into spark plug hole (Figure 3).
 - d. Slowly rotate crankshaft counterclockwise until piston bears against rope.
4. Make sure alignment marks on pulley halves are visible. If not make new marks (Figure 7).
5. Loosen retaining bolt. If clamps are not used on pulley, remember to hold pressure against pulley to keep it from springing apart. Remove retaining bolt and governor cup (Figure 8).

6. On models equipped with high performance pulley, it is necessary to use a special puller to remove pulley assembly. Perform the following:
 - a. Insert puller through pulley hub.
 - b. Gradually tighten puller.
 - c. Tap puller head to release pulley from crankshaft.
7. On models equipped with roller shaft pulleys, gently remove clamp(s) holding pulley halves together, and remove sliding half of pulley (Figure 9).
8. Loosen fixed half of pulley with a 1 1/4 in. open end wrench or large adjustable (Crescent) wrench, and remove pulley half (Figure 10).

CAUTION

Keep wrench as close to hub as possible and ensure that wrench does not slip, or damage to pulley shaft may result.



9. Refer all necessary inspection and repair to an authorized dealer.

10. Installation is the reverse of these steps. Keep the following points in mind:

- a. Lightly oil retaining bolt threads.
- b. On models equipped with high performance pulley, clean crankshaft with fine steel wool and acetone. Dry shaft with clean, dry cloth.
- c. Always use a new locking tab washer.

CAUTION

On pulleys equipped with "Duralon" bushings (Table 2), install sliding half of pulley very carefully or "Duralon" bushing may be scratched by square edge of shaft.

When installing governor cup ensure that shaft end is positioned in governor cup seat or a bent crankshaft may result.

- d. Torque retaining bolt as specified in Table 2.
- e. Perform *Pulley Alignment*.



DRIVEN PULLEY

CAUTION

Driven pulleys are matched to drive pulleys and engine. Do not use pulleys not designed for your particular machine or improper operation may result.

Removal/Installation

1. Remove drive belt.

NOTE: On TNT F/A models with self-adjusting pulley (Table 3), remove bolt and washer securing driven pulley and remove pulley.

2. On mid-engine models, remove muffler (Figure 11). On models with tuned muffler, remove muffler grommet.



3. Loosen steering column upper bracket (Figure 12).

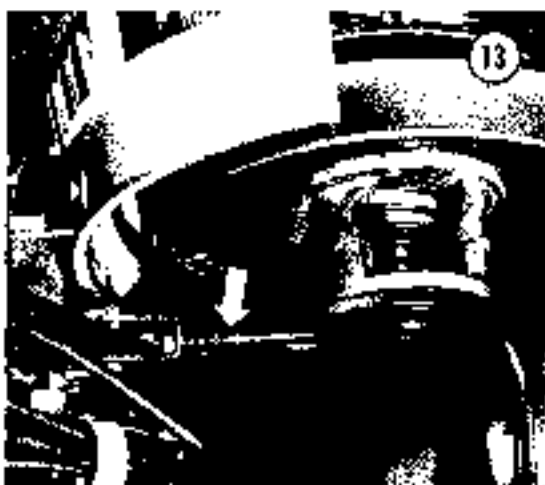

Table 3 PULLEY ALIGNMENT SPECIFICATIONS

Model	Pulley Offset	Distance Between Pulleys
All 1970 models except T'NT 340	$\frac{1}{2}$ in. (12.7mm) ¹	$1\frac{1}{8}$ in. (47.6mm) ²
All 1971 models	$\frac{1}{2}$ in. (12.7mm) ²	$1\frac{1}{8}$ in. (47.6mm) ²
All 1972-1973 except T'NT 340, 440 and T'NT F-A	$\frac{1}{2}$ in. (12.7mm) ²	$1\frac{1}{8}$ in. (47.6mm) ²
1970 T'NT 340	$\frac{3}{8}$ in. (9.5mm)	$1\frac{1}{8}$ in. (47.6mm) ²
1972-1973 T'NT 294, 340, 440	$\frac{1}{4}$ in. (11.1mm) ²	$1\frac{1}{4}$ in. (41.3mm) ²
1973 T'NT F-A, 340, 400	$\frac{1}{2}$ in. (12.7mm) ²	$10\frac{1}{2}$ in. (267mm) ²
1974 Elan and Olympique except Flan 29455 ³	$\frac{9}{16}$ in. (14.3mm) ²	$1\frac{1}{8}$ in. (47.6mm) ²
1974-1975 Elan 29455 and 30055 ⁴	$\frac{1}{16}$ in. (1.6mm) ²	$1\frac{1}{8}$ in. (47.6mm) ²
1974-1975 Flan 29455 and 30055 ⁴	$\frac{1}{2}$ in. (12.7mm) ²	$1\frac{1}{2}$ in. (38.1mm) ²
1974-1975 T'NT Everest, T'NT F-A, 245 R/V, and 1975 Olympique ⁵	$\frac{1}{2}$ in. (12.7mm) ²	$1\frac{1}{4}$ in. (34.9mm) ²
1974-1975 T'NT F-A except 245 R/V	Self-adjusting	$1\frac{1}{2}$ in. (38.1mm) ²
1976 Elan	$1\frac{1}{2}$ in. (38.1mm) ²	$1\frac{1}{2}$ in. (44.4mm) ²
1976-1979 Elan	$1\frac{11}{16}$ in. (34mm) ²	$1\frac{1}{2}$ in. (44mm) ²
1976 Olympique 300 single	$1\frac{1}{2}$ in. (38.1mm) ²	$1\frac{1}{8}$ in. (47.6mm) ²
1976 Olympique 440	$1\frac{1}{2}$ in. (38.1mm) ²	$1\frac{1}{4}$ in. (34.9mm) ²
1976 Olympique 300, 340 T'NT, Everest, and T'NT R/V	$1\frac{7}{16}$ - $1\frac{1}{2}$ in. (33.3-34.9mm)	$1\frac{1}{8}$ in. (34.9mm) ²
1978 Blizzard 6500 Plus	$1\frac{11}{32}$ in. (34mm) ²	$1\frac{3}{16}$ in. (33mm) ²
1979 Blizzard 5500	$1\frac{11}{32}$ in. (34mm) ²	$1\frac{3}{8}$ in. (36mm) ²
All other 1978-1979 models	$1\frac{11}{32}$ in. (34mm) ²	$1\frac{1}{8}$ in. (36mm) ²

1. 1971 models tolerance = $\pm \frac{1}{32}$ in. (± 0.8 mm)
2. 1971 models tolerance = $\pm \frac{1}{32}$ in. (± 0.8 mm) all other models tolerance = $0 - \frac{1}{16}$ in. ($0 - 1.6$ mm)
3. Tolerance = $\pm \frac{1}{32}$ in. (± 0.8 mm)
4. Tolerance = $\pm \frac{1}{16}$ in. (± 1.6 mm)
5. Measure between pulley centers. Tolerance = $0 - \frac{1}{16}$ in. (0-2mm) Pulley not adjustable, if out of tolerance check for mechanical wear or damage
6. Not adjustable.
7. 1974-1975 models pulley offset achieved by using a simulator rod of specified diameter between halves of driven pulley.

4. On models so equipped, disconnect driven pulley support from upper column bracket (Figure 13).



5. On models equipped with disc brakes, remove 2 bolts securing brake assembly and remove brake assembly (Figure 14).



6. Remove air silencer (Figure 15).

NOTE: On some models it may be necessary to remove exhaust to gain access to driven pulley.

7. On models equipped with aluminum chaincase, drain oil and remove chaincase cover (Figure 16).

8. On models with pressed steel chaincase, pry out inspection cover (Figure 17).



9. Loosen chain tension as follows:

- a. On 1970 model chaincases, loosen locknut and adjuster bolt and rotate adjuster (Figure 18).



- b. On aluminum chaincase models without external adjuster, release springs securing tensioner blocks (Figure 19).
- c. On models with aluminum chaincase and external adjuster, loosen adjuster bolt.

10. Remove cotter pin and remove nut and washer from upper sprocket shaft (Figure 20).

11. Hold upper sprocket and chain and remove driven pulley (Figure 21).

NOTE: On models equipped with pressed steel chaincase, wire sprocket to top of chaincase to prevent chain and sprocket from falling to the bottom of the chaincase.



12. Refer all necessary inspection and repair to an authorized dealer.

13. Installation is the reverse of these steps. Keep the following points in mind:



- a. On models *not* equipped with self-adjusting drive pulley (Table 3), tighten nut securing driven pulley and upper sprocket then back off nut $\frac{1}{2}$ turn. Install cotter pin (Figure 20).

CAUTION

Failure to back off cotterhead nut $\frac{1}{2}$ turn may result in damaged bearing on drive pulley shaft.

- b. On TNT F/A models with self-adjusting pulley (Table 3), torque pulley retaining bolt to 25 ft.-lb. (3.5 mkg)
- c. On 1970 models, adjust external tensioner bolt for $\frac{1}{4}$ in. (6.4mm) chain deflection. Measure deflection on chain through upper inspection hole in chaincase (Figure 22).



- d. On later models, chaincases with external tensioner bolt, tighten adjuster bolt for $\frac{1}{8}$ in. (6.4mm) slack measured at driven pulley (Figure 23).

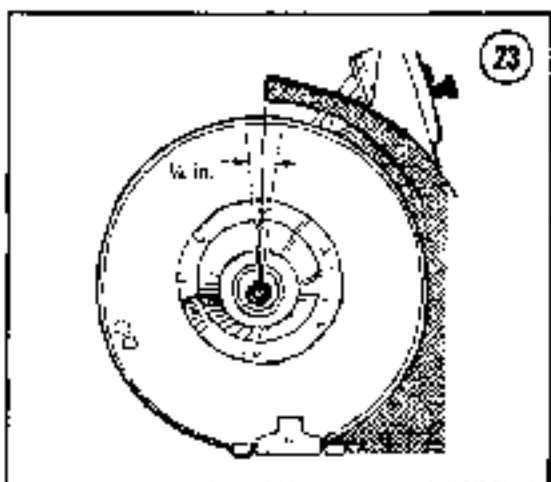

- e. Use new O-ring on aluminum chaincase cover. Tighten cover bolts gradually and evenly. Torque to 5 ft.-lb. (0.7 mkg).
 f. Add approved oil until level is flush with indicator level or plug, see Chapter Two.
 g. Perform *Pulley Alignment*.

PULLEY ALIGNMENT

CAUTION

Proper pulley/drive belt alignment is very important. A misaligned drive belt can be destroyed in a few hours of operation.

NOTE: If proper pulley alignment cannot be achieved through adjustment and the use of the proper number of shims, inspect drive components as well as frame for possible damage.

Check alignment whenever engine is installed or rapid belt wear is experienced.

Alignment (1970—1973 Models)

1. Remove drive belt.
2. Check that engine mount nuts are torqued to 33-35 ft.-lb. (4.6-4.8 mkg).
3. Using appropriate adjuster bar, check pulley offset as specified in Table 3. See Figure 24.

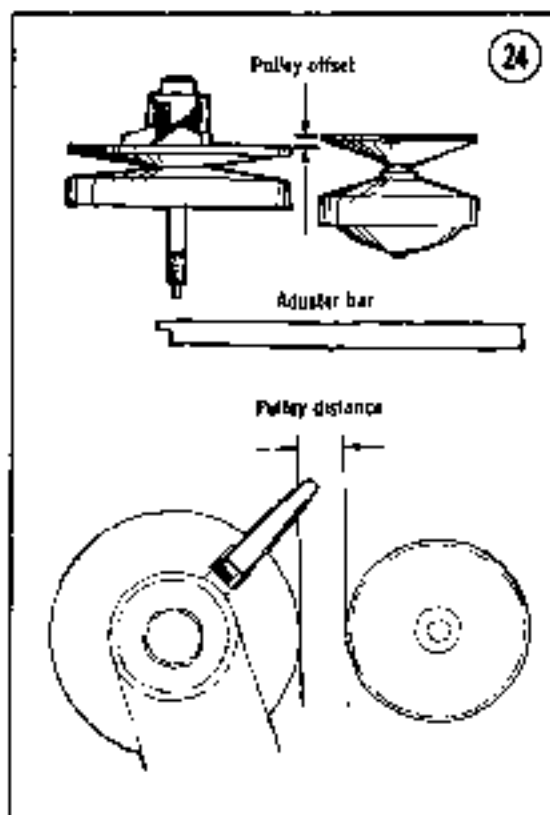

4. Check the distance between pulley rims (Figure 24). See Table 3 for specifications.
5. If offset is greater than specified value, remove drive pulley and add shims to crankshaft.

CAUTION

Do not use more than 5 shims on crankshaft.

6. If offset is less than specified, install shims between chaincase and frame.

NOTE: On steel chaincases, shim can be cut in half to correct for a bent chaincase.

CAUTION

On aluminum chaincases, always use full length shims.

7. If pulley distance is out of tolerance, loosen chaincase. Loosen driven pulley support, if necessary, and tighten or loosen hinge rod to move driven pulley to specified distance.
8. Tighten chaincase. Recheck alignment and distance.
9. Check brake operation and adjust if necessary.
10. Install drive belt.

Alignment (1974-1975 models)

1. Remove drive belt.
2. Check that the engine mount nuts are torqued to 22-30 ft.-lb. (2.9-4.1 mkg).
3. Place a piece of specified size simulator rod between driven pulley halves (Figure 25). See Table 3 for simulator rod size.
4. Use a straight end or stretched rope and check that inner halves of drive and driven pulleys are aligned (Figure 25).
5. If drive pulley is too far in, remove pulley and add shims on crankshaft.

CAUTION

Do not use more than 5 shims on crankshaft.

6. If drive pulley is too far out, loosen chaincase and install necessary shims between frame and chaincase.

NOTE: On steel chaincases, shims can be cut in half to correct for a bent chaincase.

CAUTION

On aluminum chaincases always use full length shims.

7. On TNT F/A models with self-adjusting driven pulley, alignment takes place automatically during operation. Apply anti-seize lubricant to pulley shaft to ensure its free movement. Check that pulley retaining bolt is torqued to 25 ft.-lb. (3.5 mkg).

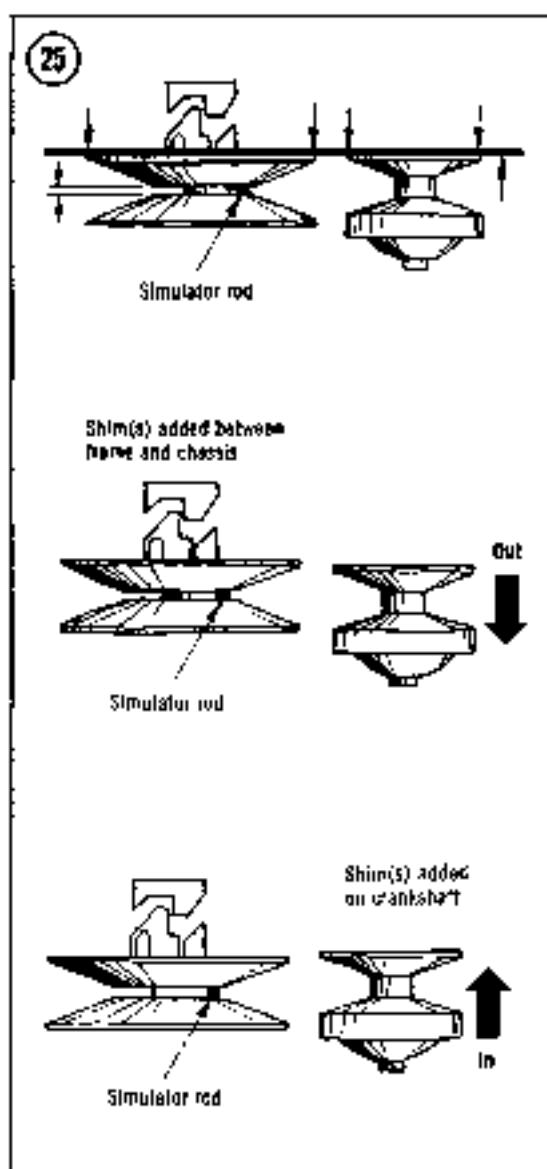

8. Check distance between pulley rims. See Table 3 for specifications.
9. If pulley distance is not as specified, loosen and adjust chaincase as necessary.
10. Check brake operation and adjust if necessary.
11. Install drive belt.

Alignment (1976 and Later Models)

1. Remove drive belt.
2. Check that engine mount nuts are torqued to 22-30 ft.-lb. (2.9-4.1 mkg).

3. Lay a 19 in. (48 cm) length of $\frac{3}{8}$ in. square bar between pulley halves (Figure 26).
4. Check pulley offset and distance as specified in Table 3.
5. On front mounted engines if pulley offset is out of tolerance, loosen engine support and adjust in required direction to obtain specified offset.
6. On center mounted engines, remove drive pulley and add shims to crankshaft.

CAUTION

Do not use more than 5 shims on crankshaft.

If drive pulley is too far out, loosen chaincase and install necessary shims between frame and chaincase.

7. If pulley distance is not as specified, loosen and adjust chaincase as necessary.
8. Check brake operation and adjust if necessary.
9. Install drive belt.

CHAINCASE, DRIVE CHAIN, AND SPROCKETS**Pressed Steel Chaincase Assembly Removal/Installation**

1. Remove driven pulley.
2. Release track tension (Chapter Two).
3. Place a drain pan beneath chaincase and pry out drive axle oil seal from chaincase with a small screwdriver (Figure 27).
4. Disconnect brake cable.

NOTE: On 1970 models with 18 in. track, remove foot rest secured to frame and chaincase (Figure 28).

5. Remove lower access plug (Figure 28) from chaincase and remove cotter pin and spacer securing lower sprocket.
6. Remove nut securing hinge rod to chaincase bracket (Figure 29).
7. Remove nut securing lower chaincase bracket and remove bracket (Figure 28).

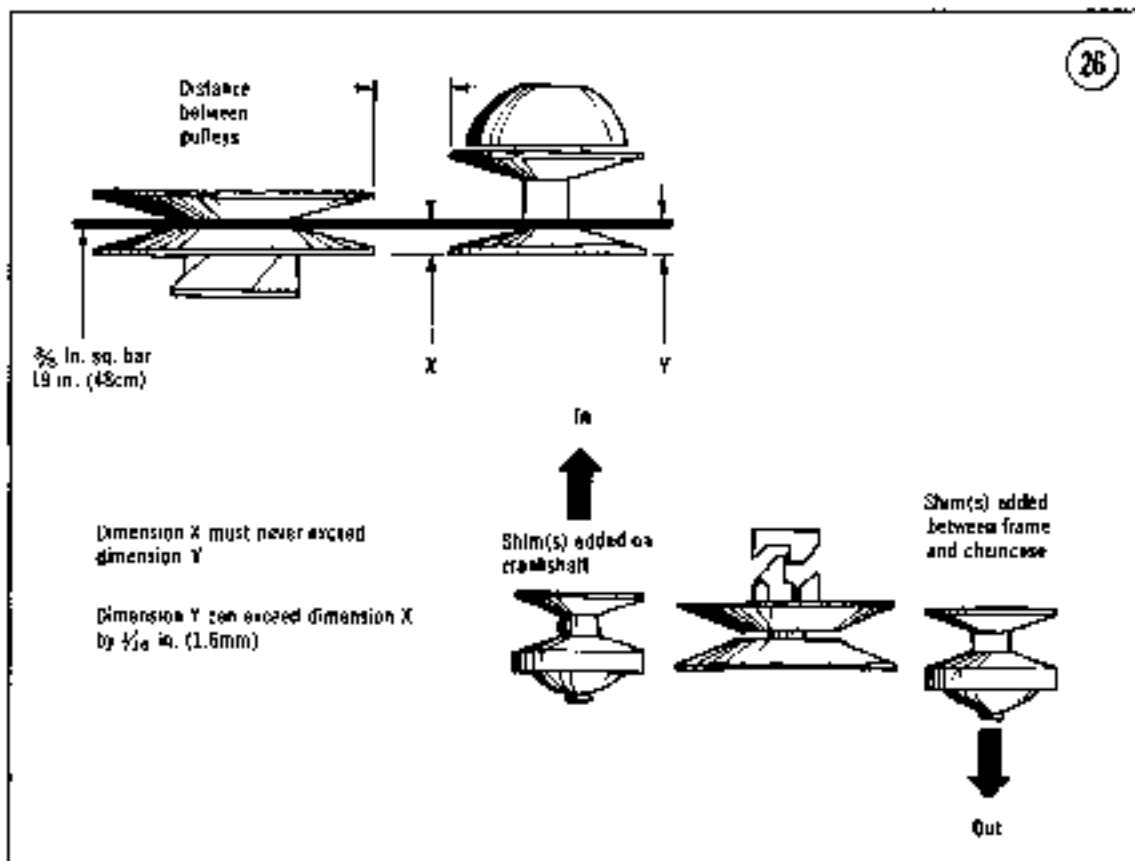

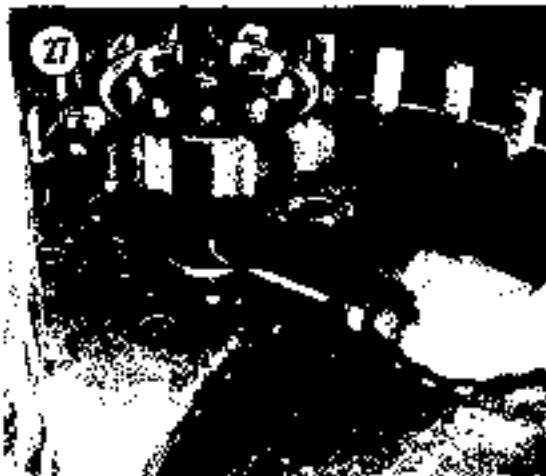

8. Remove nuts and washers from "U" clamp securing chaincase to frame (Figure 28).
9. Note number of shims, if any, between chaincase and frame and remove shims.
10. Shift chaincase and disengage hinge rod.
11. Remove drive axle.
12. Using 2 large screwdrivers between chaincase and frame, pry chaincase assembly from machine.

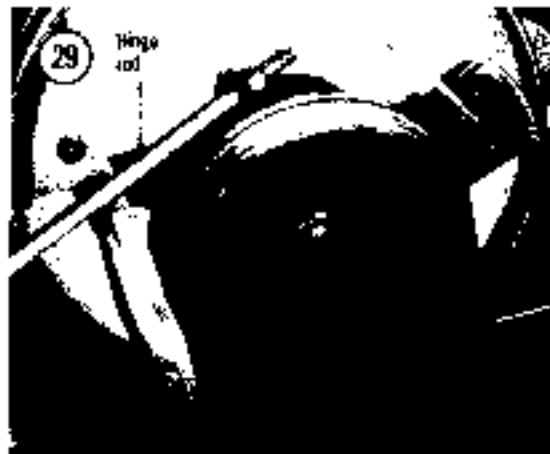

13. Perform *Inspection and Repair*.
14. Installation is the reverse of these steps. Keep the following points in mind:
 - a. Ensure that spacer is on drive axle before installing axle.

NOTE: Spacer is not installed on Elan models.

 - b. When installing oil seal on drive axle, ensure that approximately 1/4 in. (1.5mm)

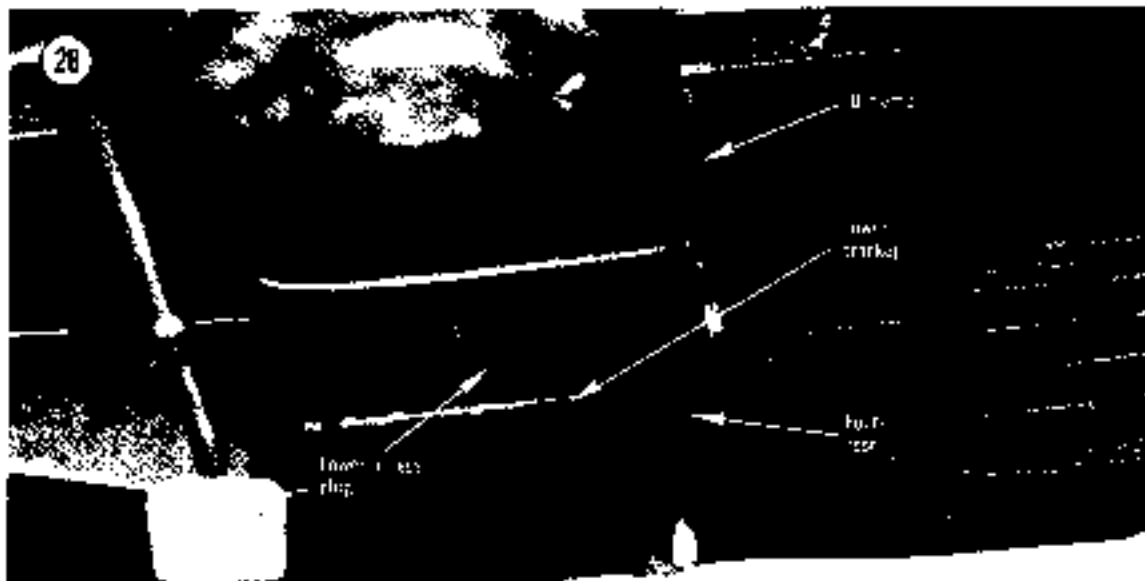

gap is present between end of chaincase flange and oil seal.

- c. On 1970 models, adjust tensioner for $\frac{1}{4}$ in. (6.4mm) chain deflection measured through chaincase inspection hole (Figure 22).
- d. Perform *Pulley Alignment*.
- e. Perform *Brake Adjustments* and *Track Tension Adjustment* as outlined in Chapter Two.
- f. Add approved chaincase oil until level is flush with chaincase plug. See Chapter Two.

Aluminum Chaincase (With Automatic Chain Tensioner) Removal/Installation

1. Remove driven pulley.
2. Release track tension (Chapter Two).
3. Pry out drive axle oil seal from chaincase with a small screw-driver (Figure 27).
4. Remove cotter pin and spacer securing lower sprocket (Figure 30). Remove lower sprocket and chain.

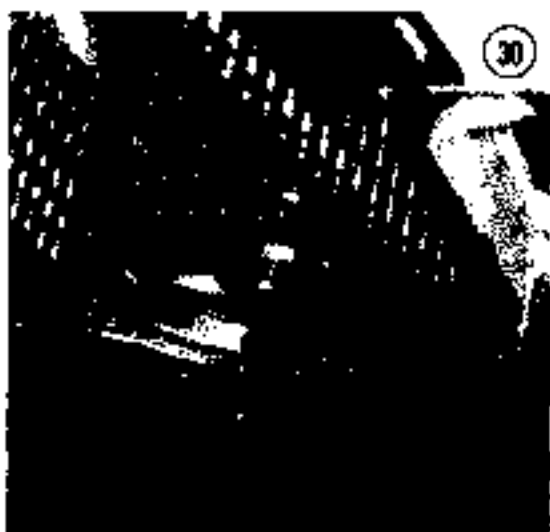

5. Remove bolts securing chaincase to frame (Figure 31). Note number of shims, if any, between chaincase and frame and remove shims. Remove chaincase (Figure 32).

6. Perform *Inspection and Repair*.

7. Installation is the reverse of these steps. Keep the following points in mind:

- a. Ensure that the spacer is on the drive axle (Figure 33).



- b. When installing oil seal on drive axle, ensure that approximately $\frac{1}{8}$ in. (1.5mm) gap is present between end of chaincase flange and oil seal.

- c. Perform *Pulley Alignment*.
- d. Perform *Brake Adjustment and Track Tension Adjustment* as outlined in Chapter Two.
- e. Use new O-ring on chaincase cover. Tighten cover bolts gradually and evenly. Torque bolts to 5 ft.-lb. (0.7 mkg).
- f. Add approved chaincase oil until level is flush with indicator level or plug, see Chapter Two.

Aluminum Chaincase (With External Chain Tension Adjuster) Removal/Installation

1. Remove driven pulley.
2. Pry out drive axle oil seal from chaincase with a small screwdriver (Figure 27).
3. Release track tension (Chapter Two).
4. Remove bolt and washer securing lower sprocket and remove sprocket.
5. Remove bolt securing chaincase to frame and remove chaincase.
6. Perform *Inspection and Repair*.
7. Installation is the reverse of these steps. Keep the following points in mind:
 - a. Tighten tension adjuster bolt for $\frac{1}{4}$ in. (6.4mm) slack measured at driven pulley level (Figure 23).
 - b. Perform *Pulley Alignment*.
 - c. Perform *Track Tension Adjustment* as outlined in Chapter Two.
 - d. Use new O-ring on chaincase cover. Tighten bolts gradually and evenly. Torque bolts to 5 ft.-lb. (0.7 mkg).
 - e. Add approved chaincase oil as outlined in Chapter Two.

Inspection and Repair

1. Inspect chain for damaged or broken rollers.
2. Inspect sprocket teeth for wear. If a new drive chain is installed, replace both sprockets. A new chain will not match worn sprockets.
3. Examine chain tensioners and replace if contact surfaces are deeply worn.
4. To replace chain, sprockets, or tensioners, perform the following:

- a. Remove cotter pin and castellated nut securing drive pulley to upper sprocket and remove drive pulley.
- b. Remove bolt securing chain tensioner to chaincase and remove tensioner (Figure 34).



- c. Inspect bearings on upper sprocket shaft and replace if damaged or worn.
- d. If replacing upper sprocket oil seal ensure that oil seal sits flush with chaincase hub.
- e. When installing lower sprocket ensure that longer flange on sprocket is toward track side of chaincase.
- f. On models not equipped with self-adjusting drive pulley (Table 3), tighten nut securing driven pulley and upper sprocket then back off $\frac{1}{4}$ turn. Install cotter pin (Figure 20).

CAUTION

Failure to back off castellated nut $\frac{1}{4}$ turn may result in damaged bearing on drive pulley shaft.

BRAKES

Pivot Brake Assembly

Removal/Installation

1. Remove drive belt.
2. Disconnect brake cable from handle plate.
3. Remove nut securing hinge rod to cross frame support (Figure 35).
4. Remove U-clamp and shims securing chaincase (Figure 28). Loosen lower bracket securing chaincase to frame.



5. Move chaincase and disengage hinge rod from cross support.
6. Remove nut securing hinge rod to chaincase and remove brake assembly with hinge rod and spring (Figure 35).
7. Examine brake lining and replace if oil-soaked or worn to level of rivets.
8. Installation is the reverse of these steps. Keep the following points in mind:

- a. Perform *Pulley Alignment*.
- b. Adjust brake cable so brake is fully applied when brake lever is $\frac{1}{2}$ in. (6.4mm) from handlebar grip.

Drum Brake Removal/Installation

Refer to Figure 36 for this procedure.

1. Remove drive belt.
2. Disconnect brake lever spring.
3. Remove bolt and cable lock bracket securing brake cable to brake lever.
4. Remove brake lever and brake assembly from machine.
5. Replace brake lining if oil-soaked or worn to level of rivets.
6. Installation is the reverse of these steps. Keep the following points in mind:
 - a. Lightly lubricate all moving parts with light oil. Do not get oil on brake shoe of drum
 - b. Adjust brake cable so brake is fully applied when brake lever is 1 in. (25mm) from handlebar grip.



- c. Check brake light operation and loosen and adjust brake light switch locknuts if necessary.

Regular Type Disc Brake

Removal/Installation

Refer to **Figure 37** for this procedure.

1. Disconnect wires from brake light switch on models so equipped.
2. Remove bolt and nut securing cable to brake lever.
3. Remove locknut from cable housing and withdraw cable.
4. Remove bolts securing brake assembly to chaincase and remove brake assembly with return spring.
5. Check brake pad thickness and replace if less than $\frac{1}{16}$ in. (4.8mm) thick.
6. Installation is the reverse of these steps. Keep the following points in mind:
 - a. Torque nuts securing brake assembly to brake support to 25 ft.-lb. (3.5 mkg).

- b. Adjust brake cable so brake is fully applied when brake lever is 1 in. (25mm) from handlebar grip.

- c. Check brake light operation and loosen and adjust brake light switch locknuts if necessary.

Heavy Duty Disc Brake

Removal/Installation

1. Disconnect brake cable from brake lever. Disconnect brake light switch spring.
2. Remove bolts securing brake assembly to brake support bracket and remove brake assembly.
3. Inspect brake pads and replace if worn level with rivets.
4. Installation is the reverse of these steps. Keep the following points in mind:
 - a. Tighten castellated adjuster nut until disc/pad friction is just felt. Screw in small adjusting screw until pads are parallel and apply equal pressure on disc. Lock small adjusting screw with jam nut.

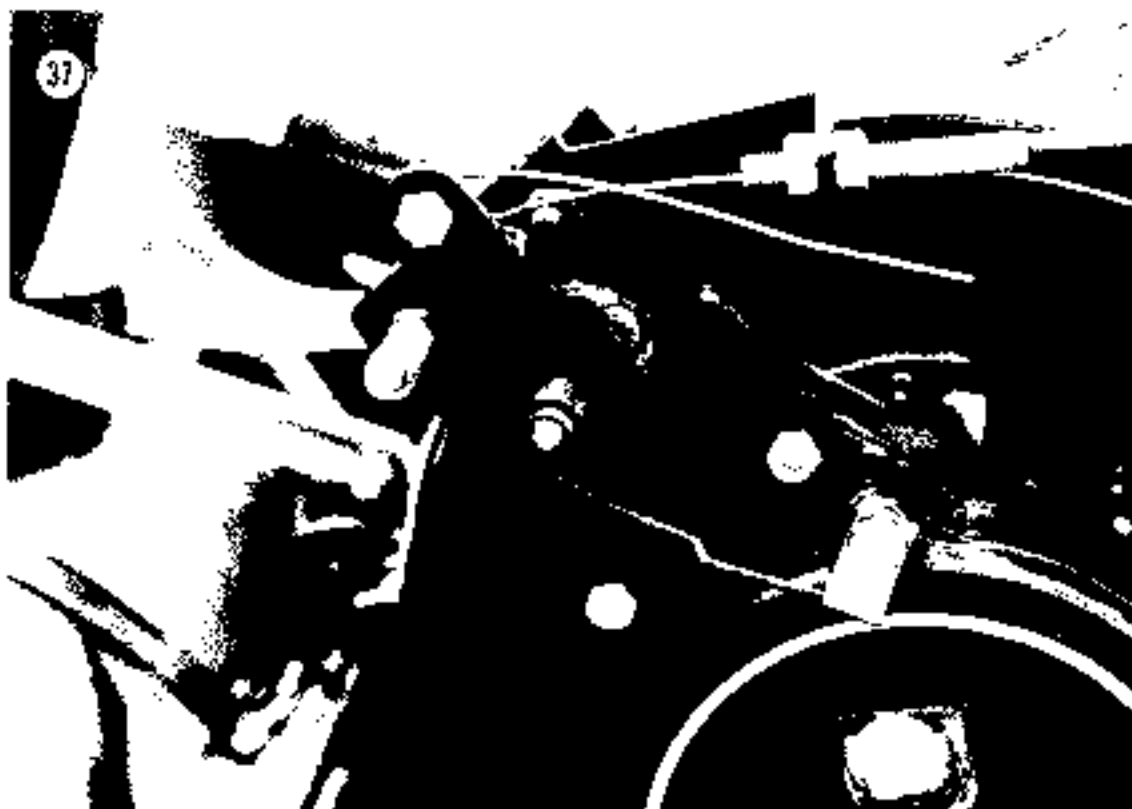

- b. Back off castellated nut slightly and secure with hair pin keeper.
- c. Tighten small cone nut then back off one turn.
- d. Adjust brake cable for 1 in. (25mm) gap between brake lever and handlebar grip when brake is fully applied.
- e. Check operation of brake light and loosen and adjust light switch locknuts if necessary.
5. Inspect brake pads and replace if less than $\frac{1}{8}$ in. (3.2mm) thick.
6. If necessary to replace pads perform the following:
 - a. Remove center pin securing retaining pin and remove retaining pin.
 - b. Slip strips of thin, stiff cardboard between pawls and ratchet wheels. Screw ratchet wheel up against stop nut.
 - c. Disengage pawls from brake pads and brake lever and remove pads.
 - d. Lightly lubricate adjusting screw threads with graphite base lubricant.
 - e. Lightly grease mating surfaces of pawls with low temperature grease.
 - f. Install pawls and position brake lever on adjusting screw stud so brake lever tab engages slot of adjusting pawl.
 - g. Apply low-temperature grease on each recess of brake lever and install sliding pad assembly over adjusting screw stud so sliding pad tab engages slot of backstop pawl.

Self-Adjusting Disc Brake (Non-Romhardler Type)

Removal/Installation

Refer to Figure 38 for this procedure.

1. Disconnect brake cable.
2. Disconnect brake light switch electrical junction block.
3. Remove locknut securing cable housing and pull out housing.
4. Remove bolts securing brake assembly and remove complete assembly.

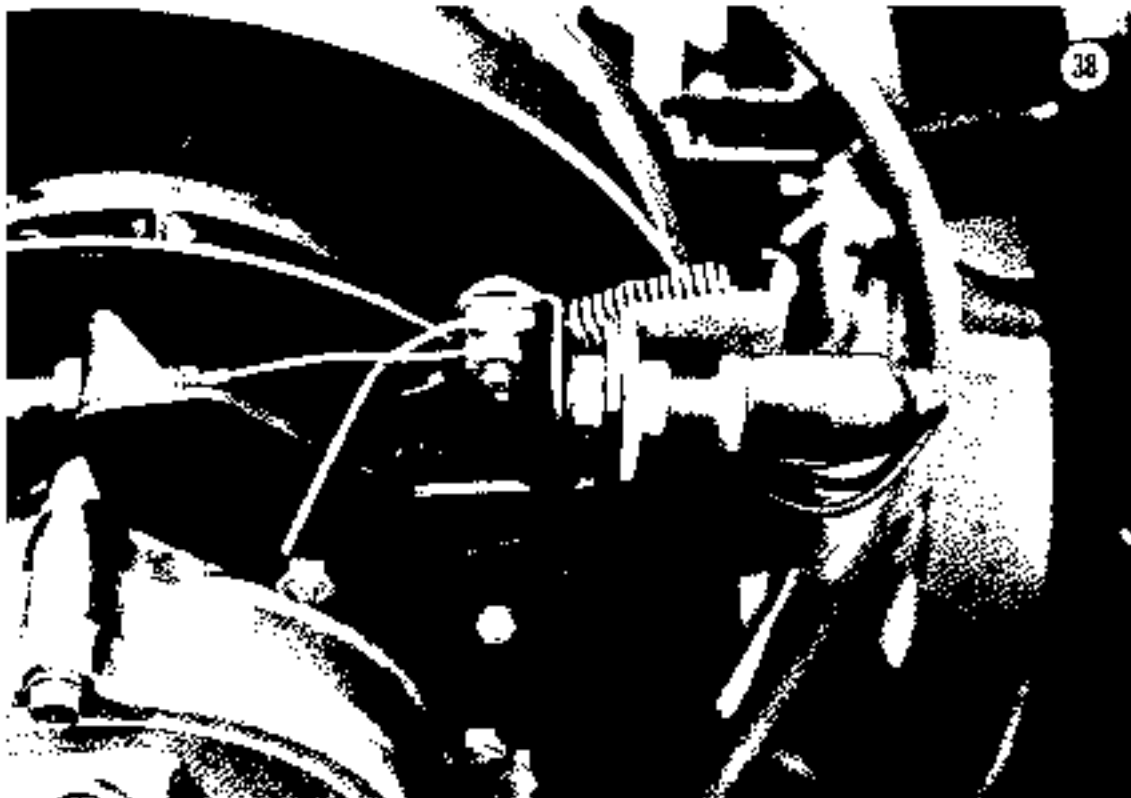

- h. Install retaining pin and secure with new cotter pin.
7. Installation is the reverse of these steps. Keep the following points in mind:
- a. With brake spring disconnected and switch tab rotated away from brake light switch, press brake lever lightly until free play is taken up. Measure and record distance between brake lever and brake light switch bracket. This is neutral position.
 - b. Secure brake cable housing to bracket, making sure adjusting nuts are halfway on housing threads.
 - c. Connect brake cable to brake lever in neutral position.
 - d. Connect brake lever spring and check neutral position. Readjust if necessary with adjusting nuts on cable housing.
 - e. Apply brake repeatedly until no more clicks are heard. Brakes must apply fully before brake lever is $\frac{1}{2}$ in. (13mm) from handlebar grip.
5. Check operation of brake light and loosen and adjust light switch locknuts if necessary.

Self-Adjusting Disc Brake (Bombardier Type) Removal/Installation

Refer to Figure 39 for this procedure.

1. Disconnect brake cable and brake light switch.
2. On models with floating caliper type brake, remove bolts securing brake support to chaincase and slide caliper assembly from brake support.
3. On models with floating disc type brake, remove bolts securing brake bracket to chaincase and remove caliper assembly.
4. Inspect brake pads and replace if oil-soaked or less than $\frac{1}{8}$ in. (3.20mm) thick.
5. Installation is the reverse of these steps. Keep the following points in mind:
 - a. Apply brake repeatedly until no more clicks are heard.



- b. Rotate cable adjusting nut until no free play exists between brake lever and brake housing.
- c. Measure gap between brake lever and caliper. Gap should be $2 \pm \frac{1}{4}$ in. (50 ± 3 mm) on floating caliper type and $1\frac{1}{2} \pm \frac{1}{4}$ in. (38 ± 3 mm) on floating disc type (Figure 40).

NOTE: On floating caliper type it may be necessary to move brake light switch supports to achieve recommended gap between lever and caliper housing.

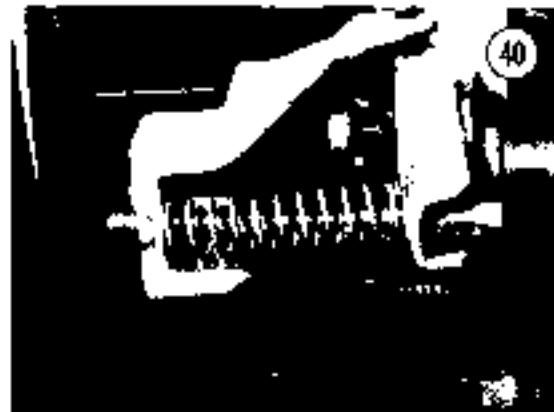

- d. On floating caliper models, torque nut securing caliper assembly to $14-17$ ft.-lb. ($1.9-2.4$ mkg).
- e. Check operation of brake light and loosen and adjust light switch locknuts if necessary.



CHAPTER EIGHT

FRONT SUSPENSION AND STEERING

The front suspension and steering consist of spring mounted skis on spindles connected to the steering column by tie rods.

All machines except T¹NT R/V models are equipped with multi-leaf springs. T¹NT R/V models use a mono-leaf spring.

Ski legs (spindles) are mounted in replaceable bushings. Ski runner shoes are also replaceable.

This chapter includes removal and installation procedures for typical steering and ski components.

SKIS

The following procedures are typical for most models. Special model details, where applicable, are noted. During removal and disassembly always note and record location of bolts of different sizes and lengths as well as shims, spacers, and lockwashers (if any) to aid assembly and installation.

Removal/Installation

1. Raise front of machine off the ground and block up securely.
2. Remove nut from ski spring coupler and unscrew bolt from coupler (Figure 1).

CAUTION

After removing nut do not attempt to drive bolt from coupler. Bolt must be



unscrewed or damage to bolt and/or coupler will occur.

NOTE: On models where spring coupler pivots directly on ski leg spindle, clamp spring leaves together with Vise Grip pliers and remove bolts and nuts securing spring coupler to springs.

3. Remove ski assembly from machine.
4. Inspect ski runner shoes. Replace runner shoes if worn more than 1/2 of their thickness.

WARNING

Ski runner shoes are under tension. Remove runner shoes carefully or injury may result.

5. Installation is the reverse of these steps. Keep the following points in mind.

- When installing spring couplers with threaded holes for coupler bolts, ensure that threaded holes are on the inside of the machine.
- Torque coupler bolts to 46-50 ft.-lb. (6.4-6.8 mkg), then torque locknut to 44-55 ft. lb. (6.1-7.6 mkg). See **Table 1**.

Table 1 SKI TORQUE SPECIFICATIONS

Components	Torque	
	Ft.-lb.	Mkg
Spring coupler to leaf spring ^a	35-40	4.8-5.5
Runner shoe		
Elar 29455 and 30055	4-5	0.6-0.7
All other models	9-12	1.2-1.7
Ski coupler		
Bolt (all models except TINT H/V)	46-50	6.4-6.9
Bolt (TINT H/V)	25	3.5
Nut	44-55	6.1-7.6
Shock absorber	33-35	4.6-4.8

^a Tighten to specified torque then loosen and retorque to specified value.

- Torque bolts securing ski coupler to spring to 35-40 ft.-lb. (4.8-5.5 mkg)
- Ensure that ski pivots freely on ski leg. Lightly lubricate ski coupler bolt with oil.
- Perform *Ski Alignment*.

Disassembly/Assembly

- Release Vise Grip pliers if used during ski removal.
- On models so equipped, remove bolts securing shock absorber, and remove shock absorber (**Figure 2**).
- Remove cotter pins securing retaining pins on front and rear of main leaf (**Figure 3**).
- Using a hammer and punch, gently tap spring retaining pins from ski, and remove springs.
- Remove spring slide cushions from front ski bracket.
- If further spring disassembly is desired,

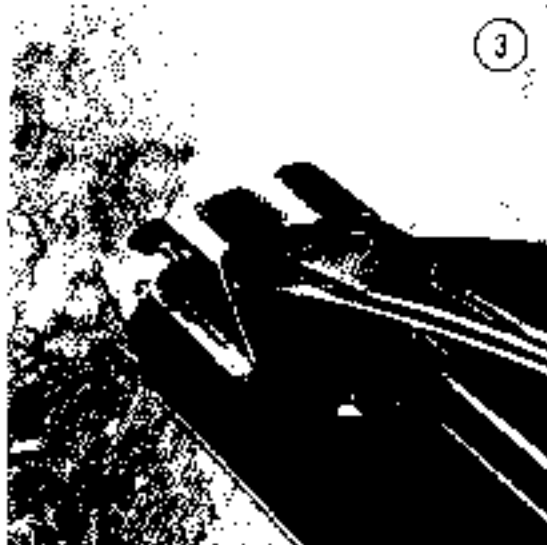

remove bolts and nuts securing spring coupler to spring and remove coupler.

- If ski runner shoe is worn to less than 1/3 its original thickness, remove nuts securing shoe to ski and remove shoe.

WARNING

Ski runner shoes are under tension. Remove runner shoes carefully to avoid injury.

- Assembly is the reverse of these steps. Keep the following points in mind:

- To aid leaf spring assembly cross leaf springs and temporarily install one bolt and nut to hold leaves together. Align springs parallel to each other and install other bolt and nut. Use *new* elastic locknuts or *new* tab locks on coupler bolts. Torque

bolts securing coupler to spring to 35–40 ft-lb (4.8–5.5 mkg).

- b. Torque nuts securing runner shoes and shock absorbers as specified in **Table 1**.
- c. Insert front and rear spring retaining pins from opposite sides. On left ski insert front pin from left and rear pin from right. On right ski insert front pin from right and rear pin from left. Use new cotter pins to secure retaining pins.

STEERING

The following procedures are typical for most models. Special model details, where applicable, are noted. During removal always note and record location of bolts of different sizes and lengths as well as shims, spacers, and lockwashers (if any) to aid installation.

Mid-Engine Model Steering Column Removal/Installation

1. Remove console.
2. On Elan models, disconnect throttle and brake cables and remove cable housings from handlebar. On Olympique models, disconnect brake cable and housing at brake assembly brake lever.
3. On models so equipped remove dimmer and cut-out buttons from handlebar.
4. On Elan models remove cotter pin, with washer and spring, securing upper tie rod end to steering column. Disengage tie rod end from steering column.
5. On other models remove nuts securing tie rod ends to steering column and disconnect tie rod ends (**Figure 4**).
6. Using a small punch and hammer, drive out pin securing steering column (**Figure 5**). Remove shims (if any) and washer.
7. Remove U-clamp (**Figure 6**) securing steering column to upper column and remove steering column.

NOTE: Do not remove steering column bushing unless bushing is to be replaced.

8. Inspect tie rod ends for excessive wear and replace if necessary. Tie rod ends attached to steering column have left-hand threads.



9. Installation is the reverse of these steps. Keep the following points in mind:

- Adjust steering column free play by adding or removing 0.025 in. (0.64mm) shims between steering column bushing and washer before installing pin.
- Tighten components to torque values specified in Table 2.
- Perform *Ski Alignment*.

Table 2 STEERING TORQUE SPECIFICATIONS

Components	Torque	
	Ft.-lb.	Mkg
Steering arm		
1970-1973 models		
Bolt	45-50	6.2-6.9
Nut	55-60	7.6-8.3
1974 and later models	18-23	2.5-3.2
Tie rod end	15-23	2.0-3.2
Handlebar	28-35	3.8-4.8

Front-Engine Model Steering Column Removal/Installation

- Remove console if so equipped.
- Disconnect throttle cable from lever and remove circlip and throttle lever housing.
- Remove dimmer and kill button from handlebar.
- On all but TNT R/V models remove bolt securing handlebar to steering column and remove handlebar.
- Remove nuts securing tie rod ends to steering column and disconnect tie rod ends (Figure 4).
- Remove nuts securing steering column to upper column (Figure 7).

NOTE: On some models it may be necessary to remove locking pin and clevis pin and raise driven pulley support (Figure 8) to gain access to tie rod ends.

- Using a small punch and hammer, drive out pin securing steering column (Figure 5). Remove shims (if any) and washer. Remove steering column.

NOTE: Do not remove steering column bushing unless bushing is to be replaced.



FIGURE 7
FIGURE 8

- Inspect tie rod ends for excessive wear or looseness and replace if necessary.

9. Installation is the reverse of these steps. Keep the following points in mind:

- Tie rod ends attached to steering column have left-hand threads. Ensure that tie rod end joint runs parallel to horizontal line of steering arm.
- If replacing tie rod end ensure that at least half of threads are screwed into tie rod.
- Hold tie rod end with wrench while tightening tie rod locknut.
- Tighten components to torque values specified in Table 2.
- Adjust steering column free play by adding or removing 0.025 in. (0.64mm) shims between steering column bushing and washer before installing pin.
- Perform *Ski Alignment*.

Ski Leg and Steering**Arm Removal/Installation**

1. Perform *Ski Removal*.
2. Remove nuts securing tie rod ends to steering arms and disconnect tie rod ends (Figure 9). On Elan models, remove cotter pin and washer and disengage tie rod from steering arm (Figure 10).



3. Remove bolts or nuts securing steering arms to ski legs. Remove arms with spacers, washers, and springs from ski leg spines. If steering arms are difficult to disengage from ski legs perform the following:
 - a. Raise front of machine.
 - b. Loosen steering arm bolt 3 or 4 turns or loosen steering arm nut until flush with ski leg.
 - c. Gently tap on bolt or ski leg end with a soft faced hammer or a hammer and block of wood to disengage splines.

4. Remove upper ski leg bushing and remove ski leg from machine. Remove lower ski leg bushing if necessary.

5. Installation is the reverse of these steps. Keep the following points in mind:
 - a. Ensure that tie rod end joints cut parallel to horizontal line of steering arm.
 - b. Tighten components to torque values specified in Table 2.
 - c. Perform *Ski Alignment*.

SKI ALIGNMENT

Ski alignment should be performed whenever steering difficulties are experienced or when repair work has been performed on ski or steering components.

1. Position snowmobile on level ground and measure distance between ski at front and rear leaf springs (Figure 11). Front dimension should be $\frac{1}{8}$ in. (3.2mm) more than rear on all models except 1973 TNT F/A which is $\frac{1}{4}$ in. (6.4mm). Ensure that handlebar is in horizontal position.

2. When measuring ski toe out manually, close front of skis to take up all mechanical slack in steering mechanism.

3. If adjustment is necessary, loosen locknuts on tie rod ends and turn tie rods to increase or decrease ski toe-out.

4. Tighten locknuts, manually close front of skis and recheck measurement. Readjust if necessary.

5. On models equipped with steering travel adjustment (Figure 12), turn handlebar fully right until gap of $\frac{1}{4}$ in. (3.2mm) exists between lower nut of left tie rod ball joint and bottom plate. Adjust stopper bolt on right side of reinforcing cross member so it just touches right steering arm. Repeat for stopper on left side.

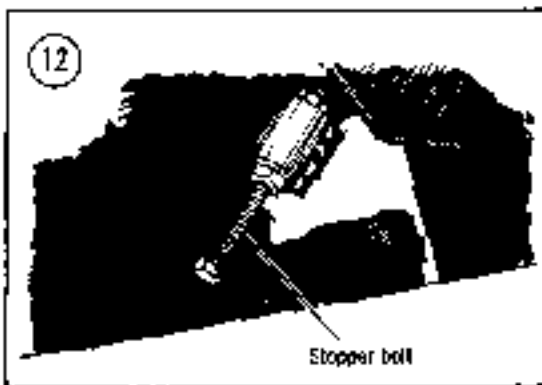

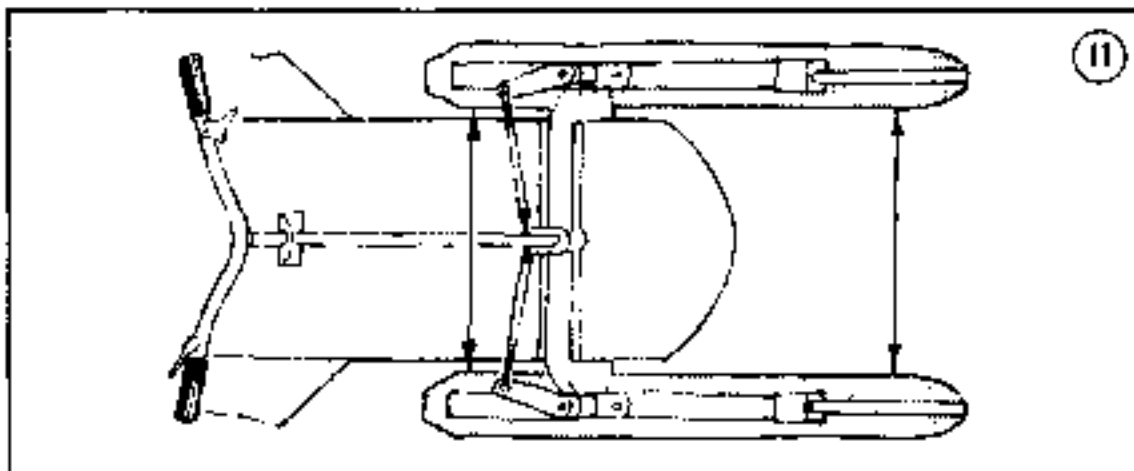

CHAPTER NINE

REAR SUSPENSION AND TRACK

Ski-Doo snowmobiles are equipped with either a bogie or slide rail rear suspension.

Elan models are equipped with 3 sets of bogie wheels, a 4-wheel set in the front and 3-wheel sets in the center and rear. All other models use 4-wheel sets in the front, center, and rear locations.

Three basic types of slide suspensions are utilized: a ground leveler, high performance, and torque reaction. See Table 1 for model application.

Table 1 SLIDE SUSPENSION MODEL APPLICATION

Model	Suspension
Olympique 1970-1974 TNT F/C 1970-1973 Elan 294 SS 1974 Elan 300 SS 1975	Ground leveler
TNT F/A 1973-1974	High performance
All other models	Torque reaction

This chapter includes removal and installation procedures for bogie and slide suspensions, track, rear axle and drive axle. Refer to Chapter Two for suspension and track adjustments and Chapter Three for *Track Wear Analysis*.

BOGIE WHEEL SUSPENSION

1. Raise rear of snowmobile off ground and block up securely.
2. Using link plate spring lever or locally fabricated equivalent, unhook link plate springs to release track tension (Figure 1).



3. Start with center bogie wheel set and remove bolts and lockwashers securing cross shaft to frame (Figure 2).



NOTE: When removing second bolt from cross shaft, wedge a screwdriver blade between shaft and support to prevent cross shaft from turning.

Remove bogie wheel set.

4. Remove front and rear bogie wheel sets.

NOTE: Springs on bogie wheel assemblies may vary depending on installation location. Mark the location of each bogie wheel set to make sure each set is installed in the proper location.

5. Refer bogie wheel assembly repair to an authorized dealer.
6. Installation is the reverse of these steps. Keep the following points in mind.
 - a. On bogie wheel sets with single springs, position wheel set with wider wheel support to front of snowmobile.
 - b. Grease each bogie wheel until new grease appears then wipe off excess.
 - c. On models with 3-position anchor for link plate spring, locate spring in middle position (Figure 1).
 - d. Perform *Track Tension Adjustment* as outlined in Chapter Two.

SLIDE SUSPENSION

Refer to **Table 1** for slide suspension model application.

Ground Leveler Suspension Removal/Installation

1. Raise rear of snowmobile off ground and block up securely.

2. Loosen spring adjuster bolt and track tension adjuster bolt to loosen track tension (Figure 3).

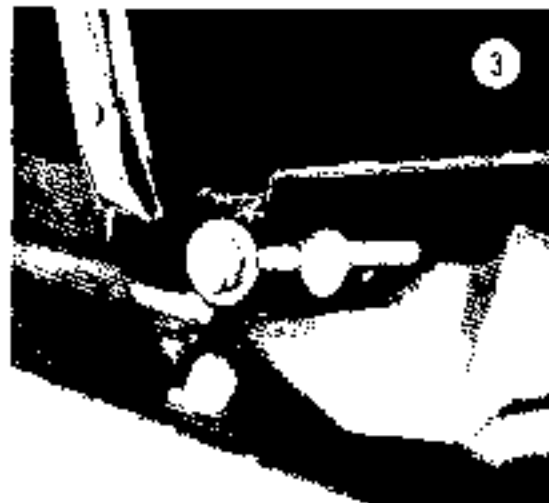

3. On 1970 models remove capscrews securing reinforcing cross shaft and remove cross shaft.
4. Use link plate spring lever or locally fabricated equivalent and unhook link plate springs (Figure 1).
5. Remove bolt securing link plate to frame (Figure 4).



6. On 1970 models, remove capscrews and washers securing 4 cross shafts to frame. It may be necessary to hold one end of cross shaft with Vise Grip pliers to remove capscrew from other end.

7. On other models remove 6 bolts securing side members to frame (Figure 5). Remove suspension.

8. Refer required suspension component repair to an authorized dealer.

9. Installation is the reverse of these steps. Keep the following points in mind:

- To ease suspension installation, apply downward pressure on front cross support and collapse suspension. Tie front cross support to front runner tube with wire to keep suspension collapsed.
- Grease front runner tube wheels and rear cross support wheels with low-temperature grease. Wipe off excess.
- Perform *Track Tension Adjustment* as outlined in Chapter Two.

High Performance Suspension Removal/Installation

1. Raise rear of snowmobile off ground and block up securely.

2. Loosen adjuster bolts on inner side of rear idler wheels to release track tension (Figure 6).



3. Loosen nuts on spring adjuster bolts to release front and rear spring tension.

4. Remove upper idler wheel assembly and withdraw suspension assembly.

5. Refer required suspension component repair to an authorized dealer.

6. Installation is the reverse of these steps. Keep the following points in mind:

- Ensure that cups are positioned over front and rear cross shaft end before locating arms in frame.

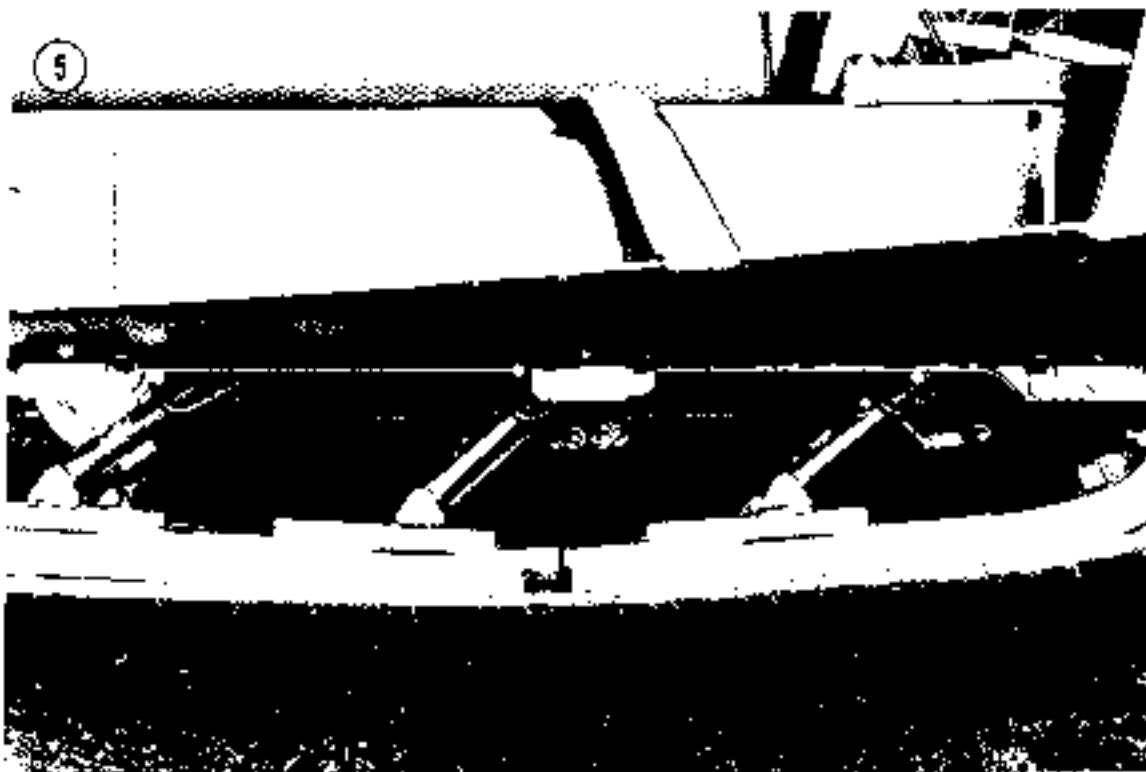

- b. Torque bolts securing front and rear arms to frame to 28-35 ft.-lb. (3.9-4.8 mkg).
- c. Torque bolts securing upper idler assembly to 28-33 ft. lb. (3.9-4.4 mkg).
- d. Perform *Track Tension Adjustment* as outlined in Chapter Two.

Torque Reaction Suspension Removal/Installation

- 1. Raise rear of snowmobile off ground and block up securely.
- 2. Loosen adjuster bolts on inner side of rear idler wheels to release track tension (Figure 7).



- 3. Position adjustment cams at lowest elevation (Figure 8).

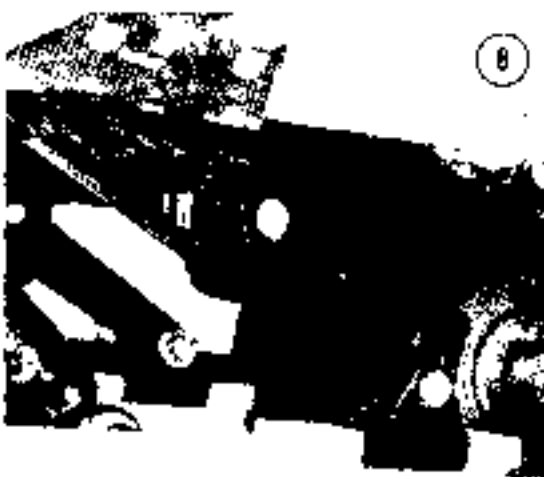

- 4. Disconnect stopper strap (Figure 9).
- 5. Apply downward pressure on seat and detach shock absorber (Figure 10).



- 6. Remove 4 bolts securing cross shafts and suspension to frame, and withdraw suspension.

NOTE: To aid removal of bolts from cross shafts, wedge the blade of a screwdriver between cross shaft and suspension arm.

- 7. Refer suspension component repair to an authorized dealer.

- 8. Installation is the reverse of these steps. Keep the following points in mind:

- a. Torque bolts securing front and rear arms to frame to 28-35 ft.-lb. (3.9-4.8 mkg).
- b. Lower machine to ground and press down on seat to connect shock absorber and stopper strap.

NOTE: Stopper strap is provided with 4 adjustment holes. The second hole (from end) provides maximum traction and

steering efficiency for most snow conditions. Using 1st hole shifts weight toward rear of machine which increases traction but decreases steering efficiency. The 3rd or 4th hole decreases traction and increases steering efficiency and effort.

- c. Perform *Track Tension Adjustment* as outlined in Chapter Two.

REAR AXLE

Removal/Installation

1. Raise rear of snowmobile off ground and block up securely.
2. Remove locknuts and retainer washers securing link plate springs (Figure 2).
3. Using link plate spring lever or locally fabricated equivalent, unhook link plate springs (Figure 1).
4. On 1970 models equipped with reinforcing cross shaft, remove bolts securing shaft and remove shaft.
5. Remove track adjuster bolts, eye bolts, link plate springs, hardener washers, and adjuster sleeves.
6. Remove rear axle assembly.
7. Perform *Inspection*. Refer necessary repair to an authorized dealer.
8. Installation is the reverse of these steps. Keep the following points in mind:
 - a. Ensure that spring anchors on link plates are up.
 - b. On models equipped with 3-position spring anchors, hook link spring in middle position.
 - c. Perform *Track Tension Adjustment* as outlined in Chapter Two.

Inspection

1. Examine sprockets for worn teeth, cuts, distortion, or other damage. Replace if necessary.
2. Inspect all oil seals for evidence of leaking or damage and replace if necessary.
3. Inspect bearings for freedom of movement and free play. If play is excessive or ball bearings are pitted or damaged, replace bearings.

4. Inspect other components including threaded parts, for damage, distortion, or excessive wear. Replace as necessary.

DRIVE AXLE

Removal/Installation

1. Remove rear suspension.
2. Remove chaincase as outlined in Chapter Seven.
3. On electric start models, remove battery cover, battery and battery platform (except Elan models).
4. On models equipped with speedometer, remove angle drive unit and coupling cable (Figure 11).

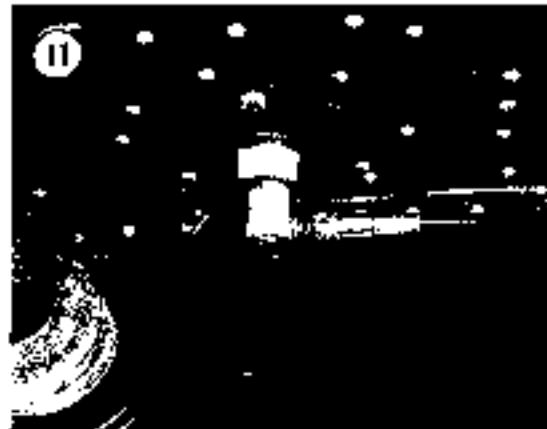

5. Tip snowmobile on its side and remove 3 capscrews securing end bearing housing (Figure 12) to frame. It may be necessary to pry housing from frame with 2 large screwdrivers.



6. Disengage sprocket teeth from track, pull drive axle towards end bearing side of frame and remove drive axle assembly (Figure 13). Do not lose spacer or shim (if so equipped) located between bearing and lower chaincase sprocket.



7. Perform *Inspection*. Refer necessary repairs to an authorized dealer.

8. Installation is the reverse of these steps. Keep the following points in mind:

- a. On speedometer equipped models, if new drive axle is installed, insert speedometer drive into axle flush with axle end (Figure 14).



- b. Install chaincase as outlined in Chapter Seven.
- c. Perform *Track Tension Adjustment* as outlined in Chapter Two.

Inspection

1. Examine sprockets for worn teeth, cuts, distortion, or other damage. Replace if necessary.
2. Inspect all oil seals for evidence of leaking or damage and replace if necessary.
3. Inspect bearings for freedom of movement and free play. If play is excessive or ball bearings are pitted or damaged, replace bearings.
4. Inspect splines for cracks or twisting and excessive wear. If splines are damaged, axle must be replaced.
5. Inspect other components, including threaded parts, for damage, distortion, or excessive wear. Replace as necessary.

TRACK

Removal/Installation

1. Raise rear of snowmobile off ground and block up securely.
2. Remove rear suspension.
3. Remove rear axle.
4. Remove drive axle and withdraw track from machine.
5. Perform *Inspection*. Refer to *Track Wear Analysis* in Chapter Three.
6. Installation is the reverse of these steps. Keep the following points in mind:
 - a. Ensure that right angle of track rib is toward front of machine.
 - b. Perform *Track Tension Adjustment* as outlined in Chapter Two.

Inspection

If abnormal wear or damage is evident, refer to *Track Wear Analysis* in Chapter Three.

1. Inspect track for cuts and abnormal wear.
2. Examine track rods. Replace track if excessive damage is evident and rods are broken.
3. Inspect track for missing or damaged inserts. Have an authorized dealer replace track inserts if necessary.

CHAPTER TEN

LIQUID COOLING SYSTEM

Certain 1978 and later Blizzard and Everest models are equipped with a liquid cooling system. The cooling system consists of a water pump, coolant tank, thermostat, and tunnel mounted radiators. Refer to Figure 1 for a typical liquid cooling system.

The thermostat maintains uniform engine temperatures throughout the engine's operation range.

The pressure cap maintains the cooling system under pressure to achieve a higher potential coolant boiling point. Coolant is a 60/40 mixture of ethylene glycol anti-freeze and water. The coolant recovery tank holds any possible system overflow. Coolant captured in the recovery tank is siphoned back into the cooling system when engine cools. See Table 1 for cooling system specifications.

COOLING SYSTEM PRESSURE TESTING

Special pressure testing tools and adapters are required for system pressure tests. For this reason, have an authorized dealer perform any necessary cooling system tests.

DRAINING AND FILLING COOLING SYSTEM

Drain and refill cooling system at least every two years.

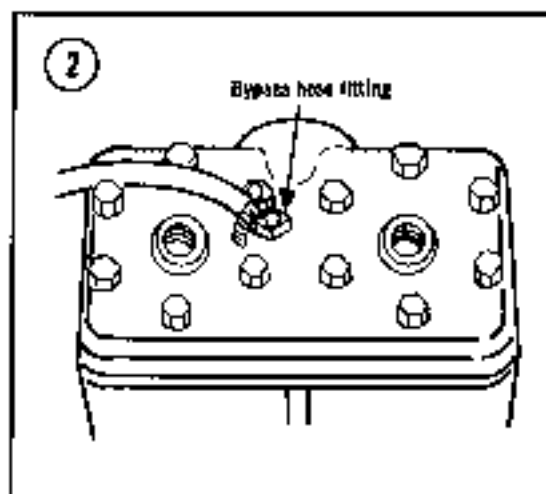

1. Remove coolant tank pressure cap and disconnect bypass hose from cylinder head fitting (Figure 2).

2. Route bypass hose into a clean container if coolant is to be kept. Block off bypass fitting and keep bypass hose as low as possible to drain the system.

3. Cover filler neck with your hand and blow through tank vent tube to completely drain the system (Figure 3). Elevate rear of snowmobile to help drain radiators.

4. Rinse engine and engine compartment with clean water.

5. Position machine on a level surface.

①

TYPICAL LIQUID COOLING SYSTEM

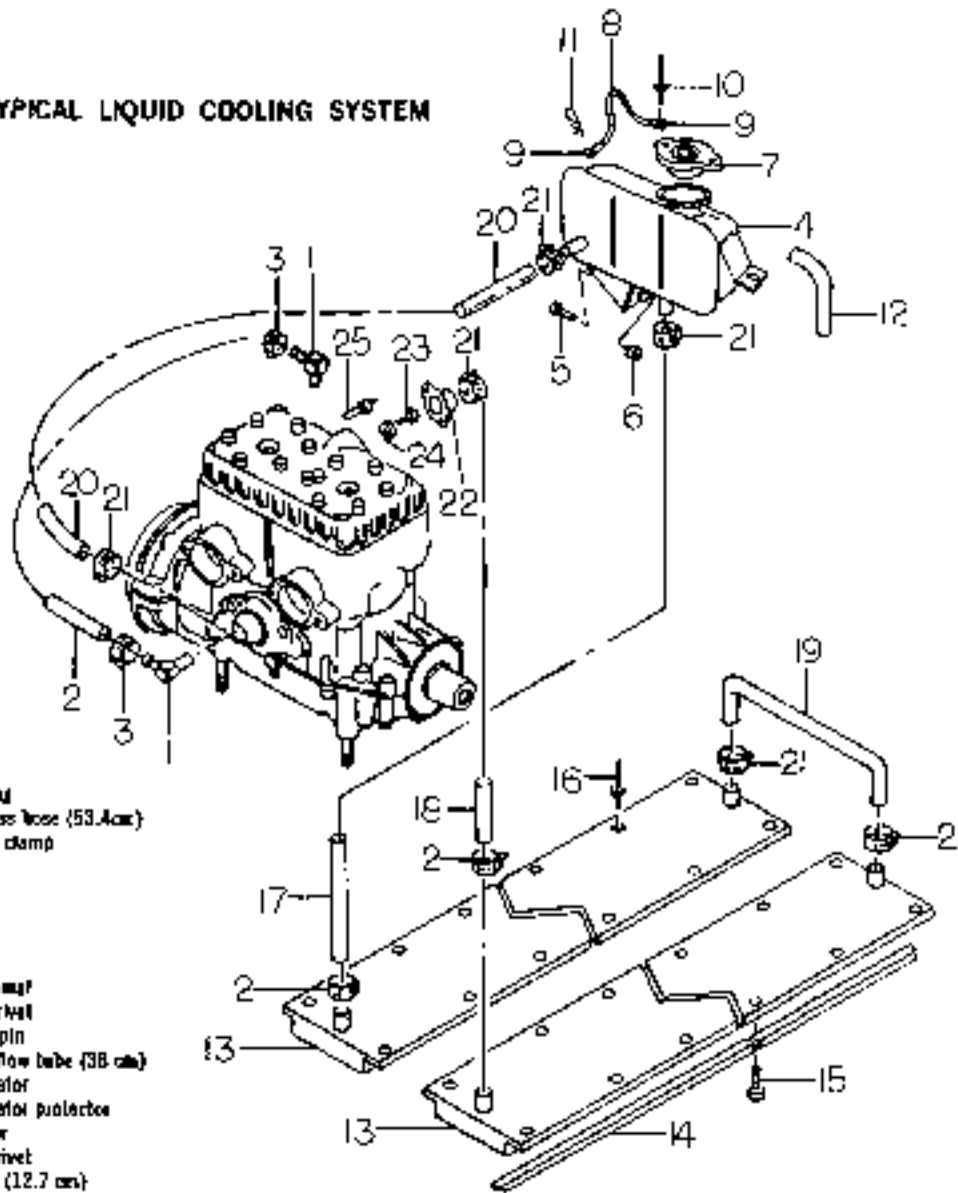

- 1. Fitting
- 2. Bypass hose (53.4cm)
- 3. Hose clamp
- 4. Tank
- 5. Bolt
- 6. Nut
- 7. Plug
- 8. Wire
- 9. Terminator
- 10. Pop rivet
- 11. Hair pin
- 12. Overflow tube (38 cm)
- 13. Radiator
- 14. Radiator protector
- 15. Screw
- 16. Pop rivet
- 17. Hose (12.7 cm)
- 18. Hose (66 cm)
- 19. U hose
- 20. Hose (66 cm)
- 21. Hose clamp
- 22. Coolant outlet collar
- 23. Thermistat
- 24. Sealing ring
- 25. Temperature gauge sender

.....
.....
.....

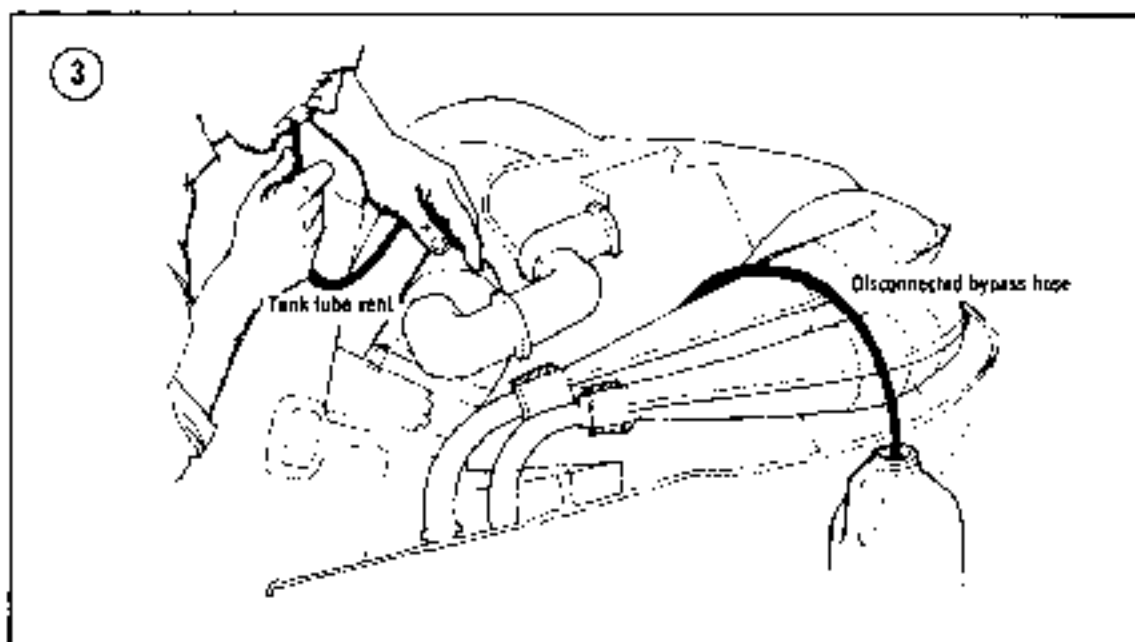

Table 1 COOLING SYSTEM SPECIFICATIONS

Engine	Liter	Coolant Capacity* U.S. Gal.	Imp. Gal.
354	2.5	0.6	1.5
444	5	1.2	1.0
Pressure cap		13 ps.	
Coolant mixing ratio		60% anti-freeze 40% water	
Thermostat opening temperature		110°F (43°C)	
*Coolant capacities are approximate. After cooling system is bled, fill until coolant level is 1 in. (25mm) below filler neck.			

6. Keep bypass hose near fitting on cylinder head and fill coolant tank with proper mixture of anti-freeze and water.
7. Cover filler neck with your hand and blow through tank vent tube until coolant comes out the bypass hose and the fitting on the cylinder head (Figure 4). Keep coolant tank full while purging the system of air.
8. Connect bypass hose and fill coolant tank until level is 1 in. (25mm) below filler neck. Refer to Table 1 for approximate coolant capacities.
9. Check all hose connections for leaks. Install filler cap.
10. Block up rear of machine to clear track off the ground.

11. Start engine and warm up to operating temperature. Check entire cooling system for leaks.

12. Shut off engine and let cool. Recheck coolant level.

TIHERMOSTAT REMOVAL/INSTALLATION

Refer to Figure 1 for this procedure.

1. Drain cooling system.
2. Remove bolts securing thermostat housing and remove housing. Lift out thermostat. If engine has been running too cold or overheating, replace thermostat.

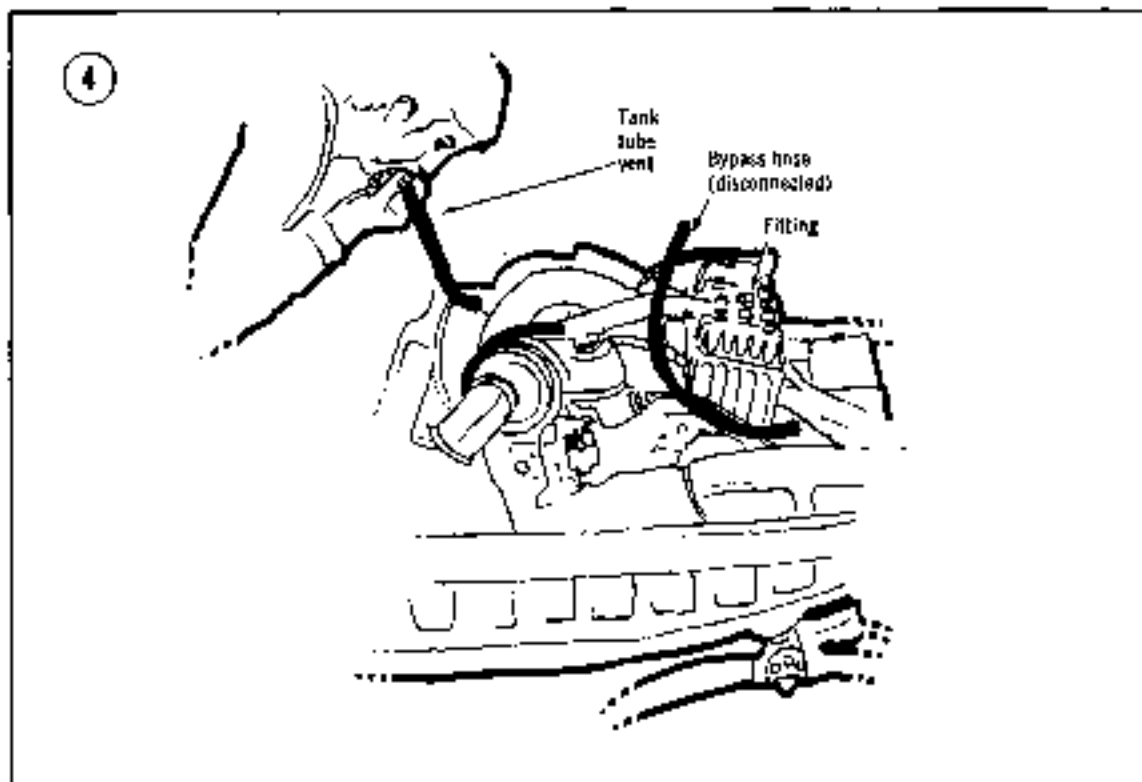

3. Installation is the reverse of these steps. Use a new gasket on thermostat housing. Fill cooling system as outlined under *Draining and Filling Cooling System*.

WATER PUMP REMOVAL/INSTALLATION

Refer to **Figure 5** for this procedure.

1. Drain cooling system.
2. Loosen clamps securing coolant hoses to water pump housing.
3. Remove bolts and O-ring gaskets securing pump housing and remove housing. Remove and discard pump housing gasket.
4. Remove locking nut and washer securing pump impeller to pump shaft; and remove impeller.
5. If pump shaft, bearings, and seal removal is desired, perform *Rotary Valve Removal* as outlined in Chapter Four. Refer shaft, bearing and seal replacement to a dealer.
6. Installation is the reverse of these steps. Keep the following points in mind:
 - a. Install a new pump housing gasket.
 - b. Apply Loctite Lock 'N' Seal to bolts securing pump housing.
 - c. Secure coolant hoses and fill cooling system as outlined in *Draining and Filling Cooling System*.

RADIATOR REMOVAL/INSTALLATION

Refer to **Figure 1** for this procedure.

1. Drain cooling system.
2. Refer to Chapter Nine and perform *Torque Reaction Suspension Removal/Installation*.
3. Remove screws securing radiator protector strips and remove strips.
4. Disconnect radiator hoses.
5. Using a cold chisel, gently remove rivets securing radiators.
6. Installation is the reverse of these steps. Pop rivet radiators in channel from the top. Refer radiator repair to an authorized dealer. Fill cooling system as outlined under *Draining and Filling Cooling System*.

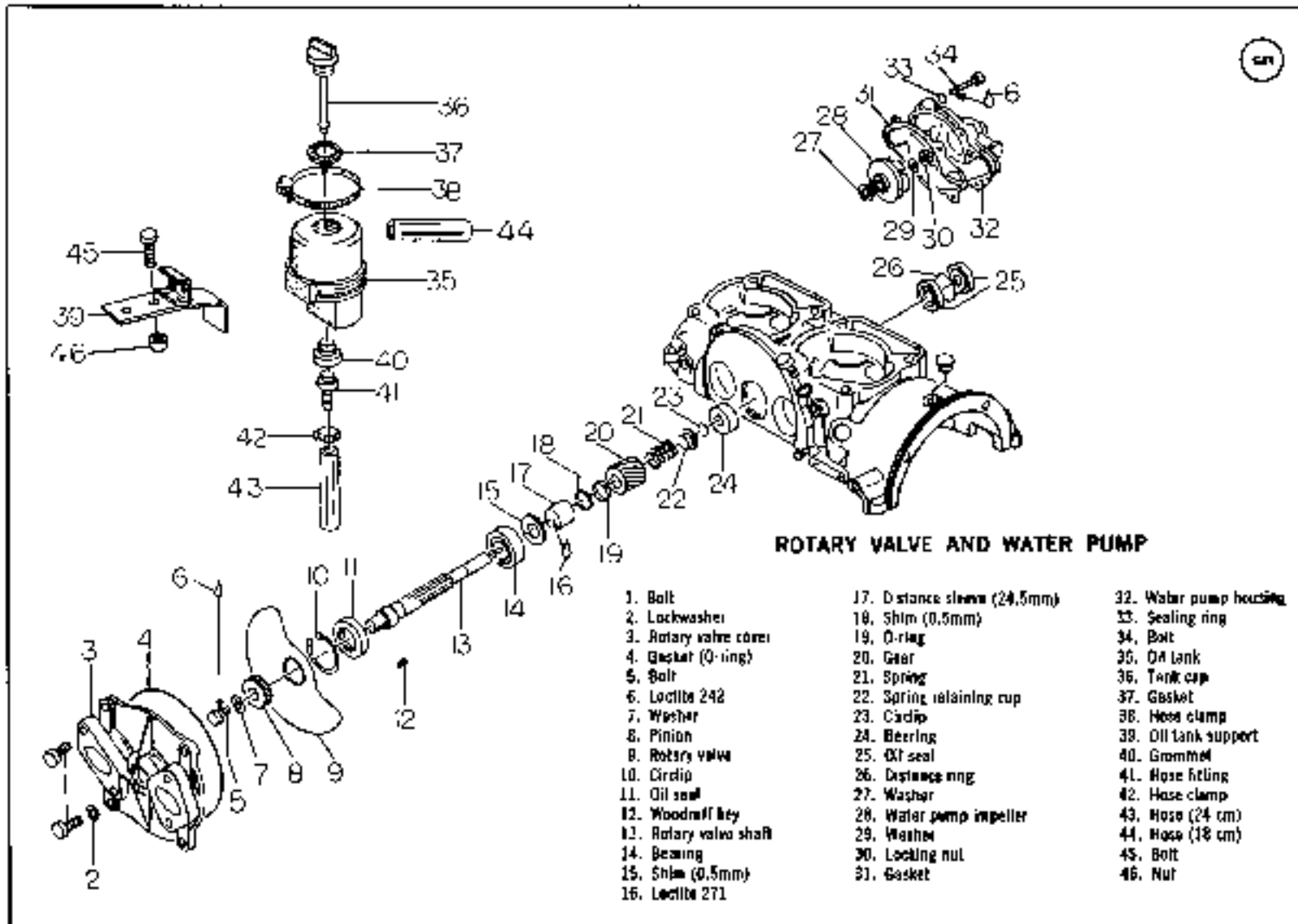

INDEX

A	
Air intake silencer	102
Avics	148-149
B	
Battery	116-117
Bogie wheel suspension	15-16, 144-145
Brakes	
Adjustment	11-12
Bleeding hydraulic disc brake	12-13
Removal and installation, Bombardier type self-adjusting disc brake	136-137
Removal and installation, drum brakes	133-134
Removal and installation, heavy duty disc brakes	134-135
Removal and installation, non-Bombardier type self-adjusting disc brakes	135-136
Removal and installation, pivot brake	132-133
Removal and installation, regular disc brake	134
Brake/tail light	114
Breaker points (single cylinder engines)	22-26
Breaker points (twin cylinder engines)	26-28
C	
Carburetor (Mikuni)	
Adjustment and synchronization	33-36
Assembly	101-102
Cleaning and inspection	99-101
Disassembly	99
Flow meter synchronization	35-36
Main jet selection	36
Removal and installation	98-99
Specifications	108-109
Carburetor (Tillotson)	
Assembly	97-98
Cleaning and inspection	97
Disassembly	95-96
Removal and installation	89-95
Specifications	109
Throttle cable adjustment	31
Tune-up adjustment	31-33
CDI system	110-113
CDI timing	28-31
Chaincase, drive chains, and sprockets	129-132
Chaincase oil level	13-14
Clothing, proper	3
Code of ethics	7-8
Compression test	41
Connecting rods	59
Crankcase	58
Crankshaft inspection	59
Crankshaft (single cylinder engines)	57
Crankshaft and rotary valve (twin cylinder engines)	75-77
Cylinder bore and head	56
Cylinder head, cylinder, piston, and ring (single cylinder engines)	54-56
Cylinder head, cylinder, piston, and ring (twin cylinder engines)	67-75
D	
Drive axle	148-149
Drive belt	11, 44-47, 119-120
Drive chains and sprockets	129-132
Drive pulley	10-11, 120-123, 127-129
Driven pulley	10-11, 123-129
E	
Electrical system	
CDI system	110-113
Electric starting system	115-118
Lighting system	113-115
Magneto ignition	113
Troubleshooting	43-44
Emergency starting and stopping	3
Emergency survival techniques	9
Engine	
Component inspection	57-59
Cooling fan (twin cylinder engines)	81-83
Crankshaft (single cylinder engines)	57
Crankshaft assembly and rotary valve (twin cylinder engines)	75-77
Cylinder head, cylinder, piston, and ring (single cylinder engines)	54-56
Cylinder head, cylinder, piston, and ring (twin cylinder engines)	67-75
Exterior components (single cylinder Engines)	52
Failure analysis	42-43
Fan belt (twin cylinder engines)	83
Fan cowling, fan, and magneto (single cylinder engines)	53-54
Flywheel, magnets, and cooling fan (twin cylinder engines)	62-67
Operating principles of 2-cycle engines	39
Operating requirements	38-39
Performance	41-42
Recoil starter	83-85
Removal and installation (single cylinder engines)	51-52
Removal and installation (twin cylinder front engine models)	59-62



- Removal and installation (twin cylinder mid-engine models) 59-62
 - Rarity valve timing 81
 - Specifications and tightening torques 86-88
 - Starting 39-41
 - Top end and complete overhaul 50
 - Troubleshooting 39-43
 - Tune-up 18-36
- F**
- Fan and belt inspection 10, 57
 - Fan and fan belt (twin cylinder engines) 81-83
 - Fan cowl, fan, and magneto 53-54
 - Fan belt adjustment 83
 - Flywheel and magneto (twin cylinder engines) 62-67
 - Fuel mixing 2, 42
 - Fuel system
 - Air intake silencers 102
 - Fuel filter 10, 102, 107
 - Fuel pump 107
 - Fuel tank 102
 - Mikuni carburetor 33-36
 - Specifications 108-109
 - Tillotson carburetor 31-33, 89-98
- G**
- General information 1-9
- H**
- Hardware and component tightness check 18
 - Headlight 114-115
- I**
- Identification numbers 2
 - Ignition system (CDI) 110-113
 - Ignition system, magneto 110
 - Ignition timing (CDI) 28-31
 - Ignition timing (single cylinder engines) 22-26
 - Ignition timing (twin cylinder engines) 26-28
- L**
- Lighting system 113-115
- M**
- Magneto (single cylinder engines) 53-54
 - Magneto (twin cylinder engines) 62-67
 - Magneto ignition 110
 - Maintenance (also see Tune-up)
 - Brakes 31-33
 - CDI timing 28-31
 - Chaincase oil level 13-14
 - Drive and driven pulleys 10-11
 - Drive belt 31
 - Engine tune-up 18-36
 - Fan belt tension 10
 - Hardware and component tightness check 18
 - In-line fuel filter 10
 - Schedule of maintenance 11
 - Slide suspension ride adjustment 16-17
 - Spark plugs 20-22
 - Storage (off-season) 36-37
 - Track tension adjustment 14-16
- O**
- Operation 2-3, 8-9, 38-39
 - Overhaul, complete 50
- P**
- Parts identification 2
 - Piston inspection 57-59
 - Piston and ring (single cylinder engines) 57-59
 - Piston and ring (twin cylinder engines) 67-72
 - Power train
 - Chaincase, drive chain, and sprockets 129-132
 - Drive belt 119-120
 - Drive pulley 120-123
 - Driven pulley 123-127
 - Pulley alignment 127-129
 - Troubleshooting 44
 - Pulley alignment 127-129
- R**
- Recoil starter 83-85
 - Rectifier 118
- S**
- Safety 7, 8-9
 - Service hints 3-5
 - Single cylinder engines 51
 - Skis
 - Alignment 142-143
 - Removal, disassembly, assembly, and installation 138-140
 - Troubleshooting 47
 - Slide suspension 16, 145-147
 - Spark plugs 20-22, 40
 - Specifications, engine 86-88
 - Starter, recoil 83-85
 - Starting and stopping, emergency 3
 - Starting system, electric 115-118
 - Starting troubleshooting 39-41
 - Steering
 - Ski leg and steering arm 142
 - Steering column (front engine models) 141
 - Steering column (mid-engine models) 140-141
 - Troubleshooting 47
 - Storage (off-season) 36-37
 - Supplies, expendable 6-7
 - Suspension, front 128-143
 - Suspension, rear
 - Bogie wheel suspension 144-145
 - Drive axle 148-149
 - Rear axle 148
 - Slide suspension 16-17, 145-148
 - Track 14-16, 149

T

- Throttle cable adjustment (Tillotson carburetor) 31
- Tillotson carburetor 89-98
- Timing (CDI) 29-31
- Timing (single cylinder engines) 22-26
- Timing (twin cylinder engines) 26-28
- Tools 5-6
- Torque reaction suspension 17
- Towing 3
- Track
 - Assembly 47
 - Clearing 3
 - Removal, inspection, and installation 149
 - Tension adjustment 14-16
 - Troubleshooting 47-49
 - Wear analysis 47-49
- Troubleshooting
 - Drive belt wear analysis 44-47
 - Electrical system 43-44
 - Engine failure analysis 42-43
 - Engine performance 41-42
 - Engine starting 39-41
 - Operating principles, 2-cylinder engines 39
 - Operating requirements 38-39
- Power train 44
- Skis and steering 47
- Track assembly 47
- Track wear analysis 47-49
- Tune-up
 - Breaker point and timing adjustment (single cylinder engines) 22-26
 - Breaker point and timing adjustment (twin cylinder engines) 26-28
 - Carburetor adjustments (Mikuni) 33-36
 - Carburetor adjustments (Tillotson) 31-33
 - General information 18-20
 - Spark plugs 20-23
 - Throttle cable adjustment (Tillotson carburetor) 31
 - Timing (CDI) 28-31
- Twin cylinder engines 59-62

W

- Wind chill factors 4
- Wiring diagrams end of book



1970 OLYMPIQUE 335E

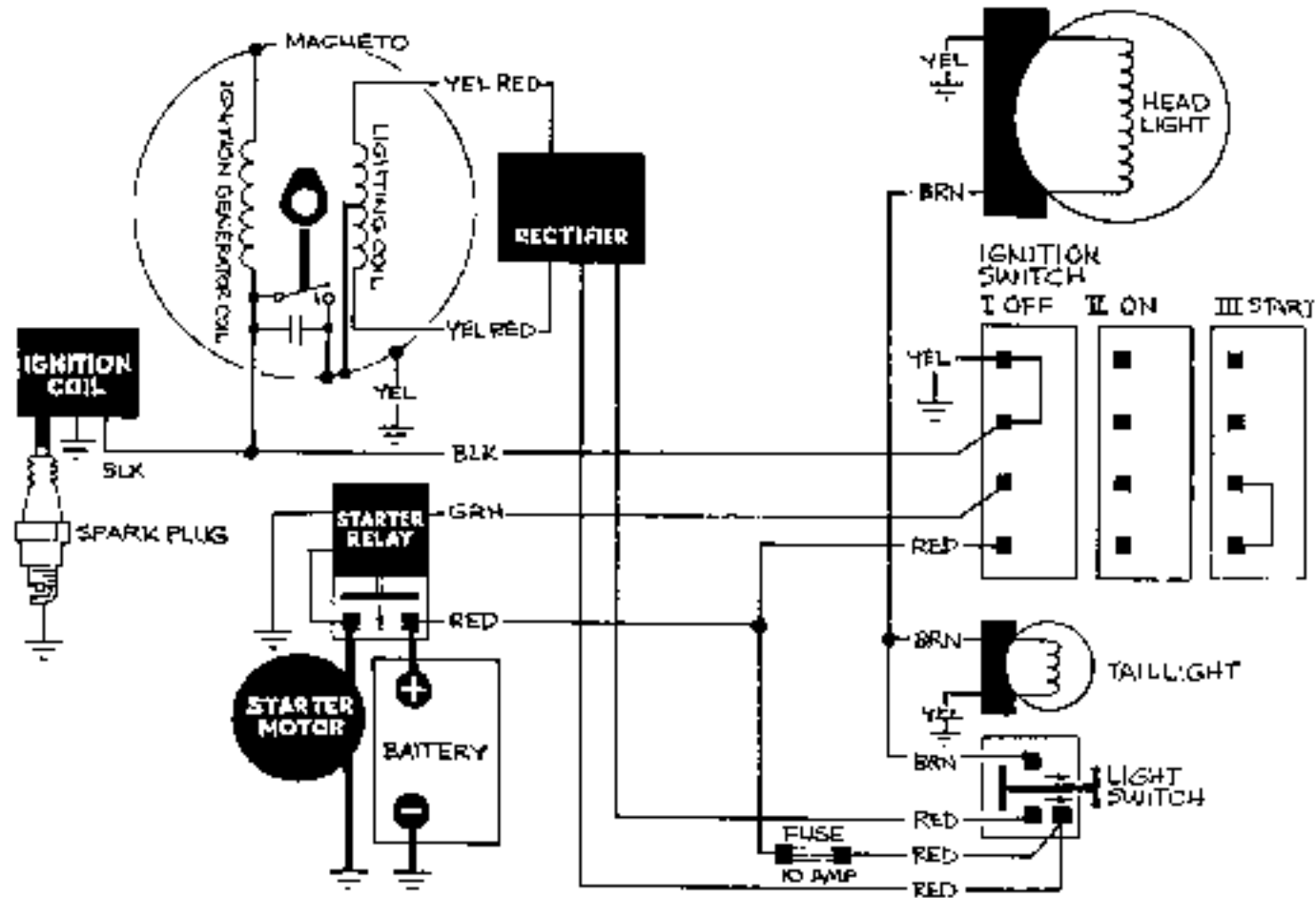

1970 OLYMPIQUE 335, TNT 292, 340

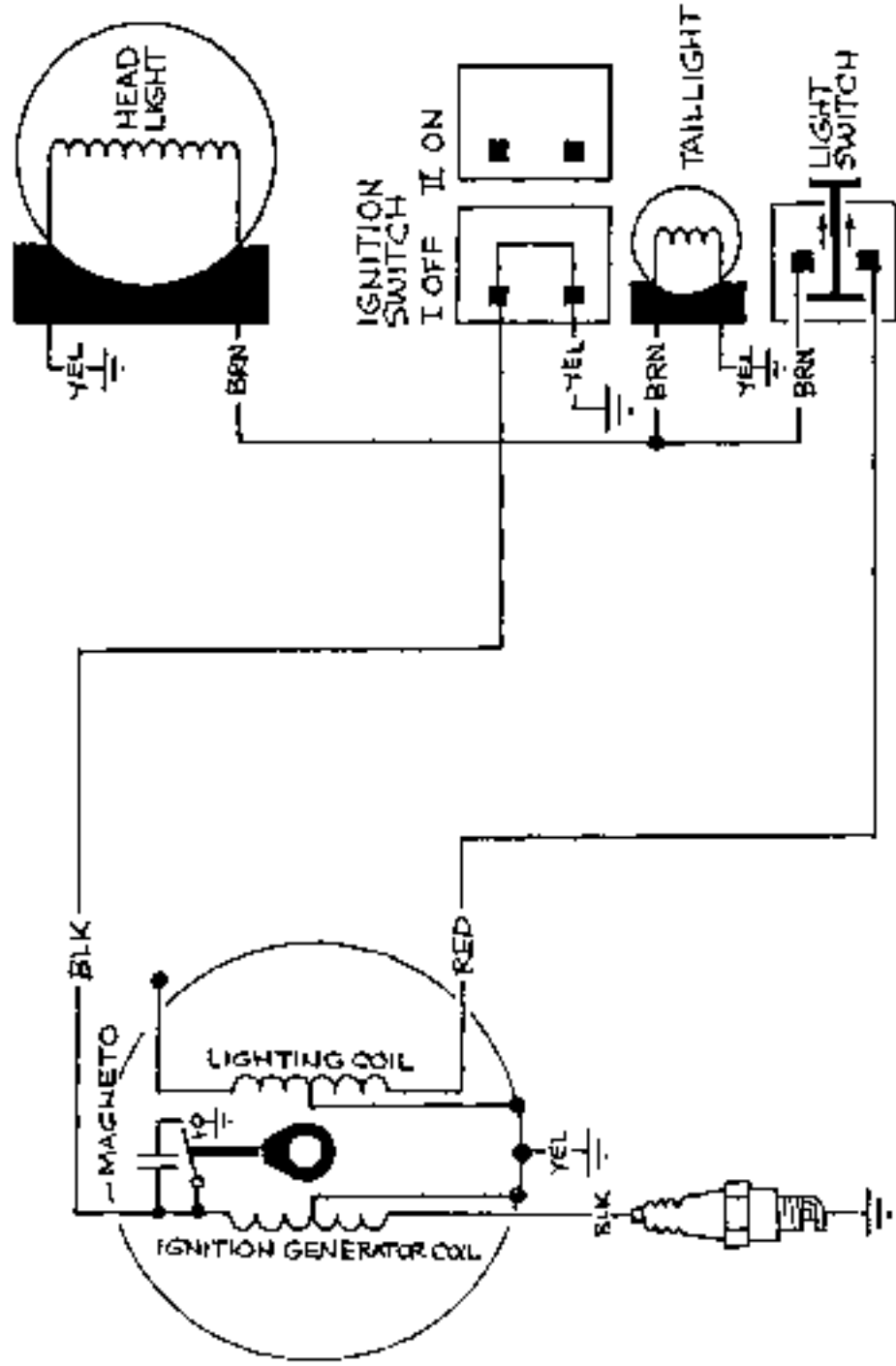

1970 TNT 399, OLYMPIQUE 399
1971 TNT 440, OLYMPIQUE 399

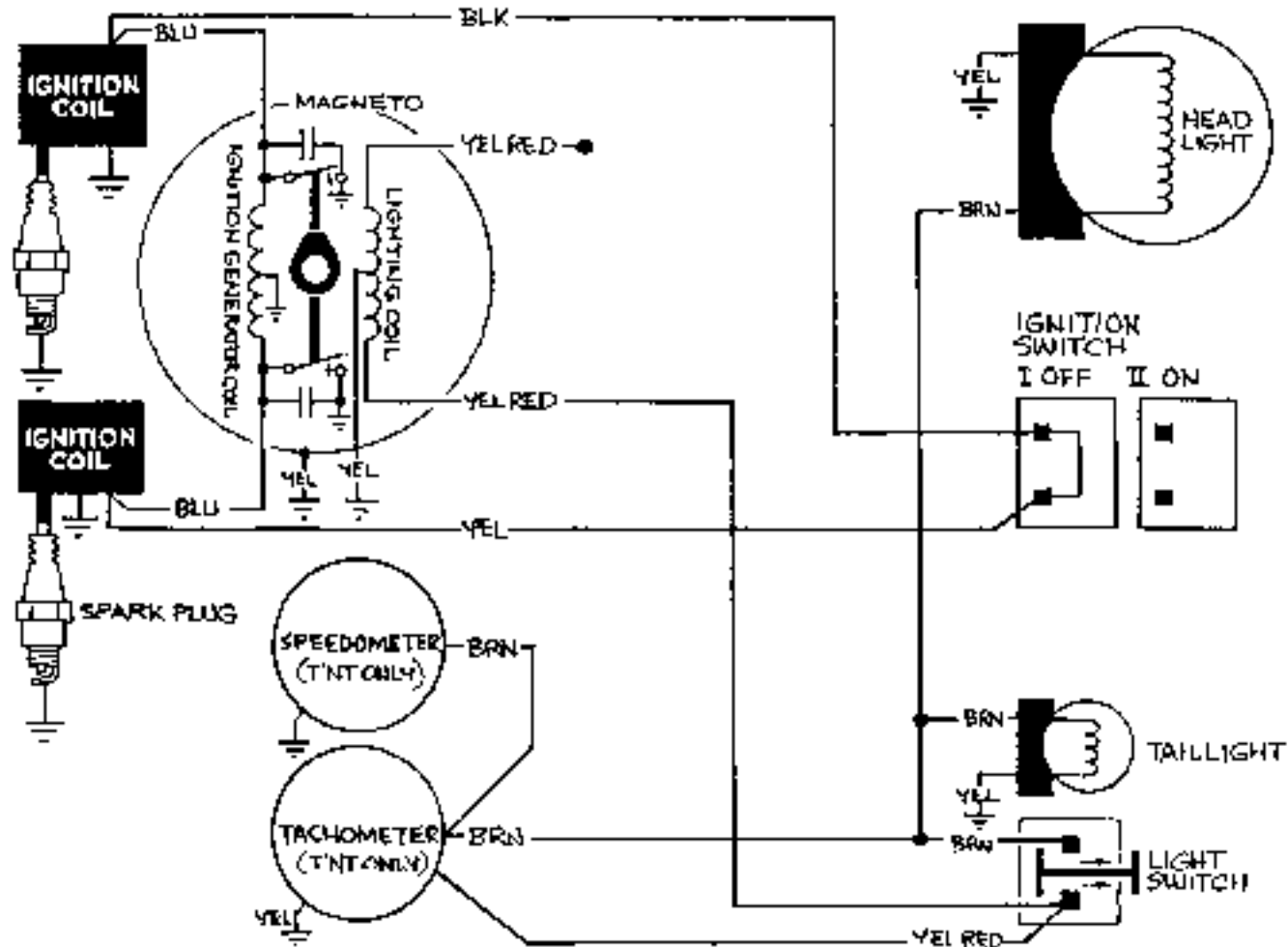

1971 ELAN 250, T'NT 292-340, OLYMPIQUE 300-350

1972 ELAN 250, OLYMPIQUE 300-350

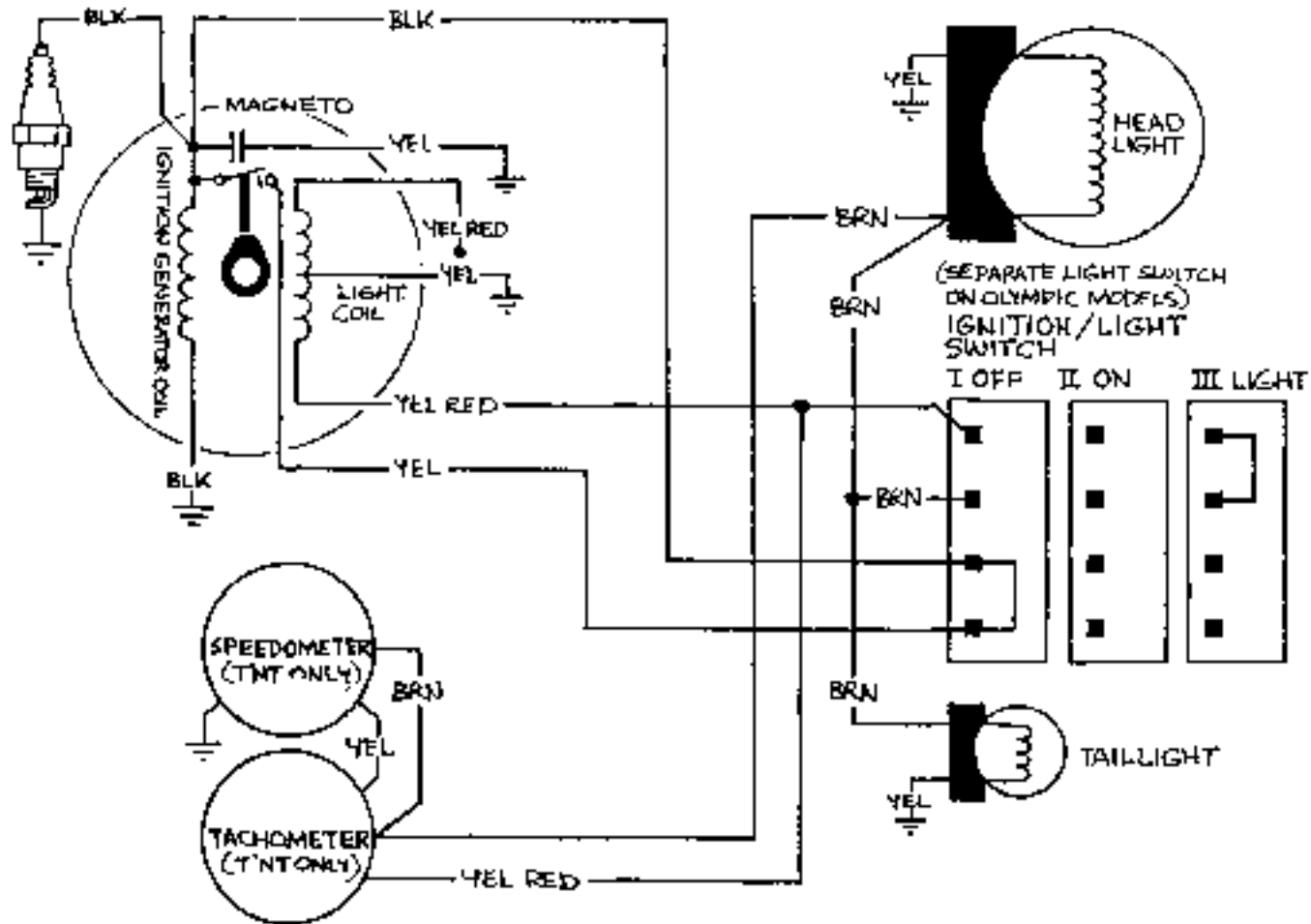

1971 OLYMPIQUE 335E, 399E, ELAN 250E

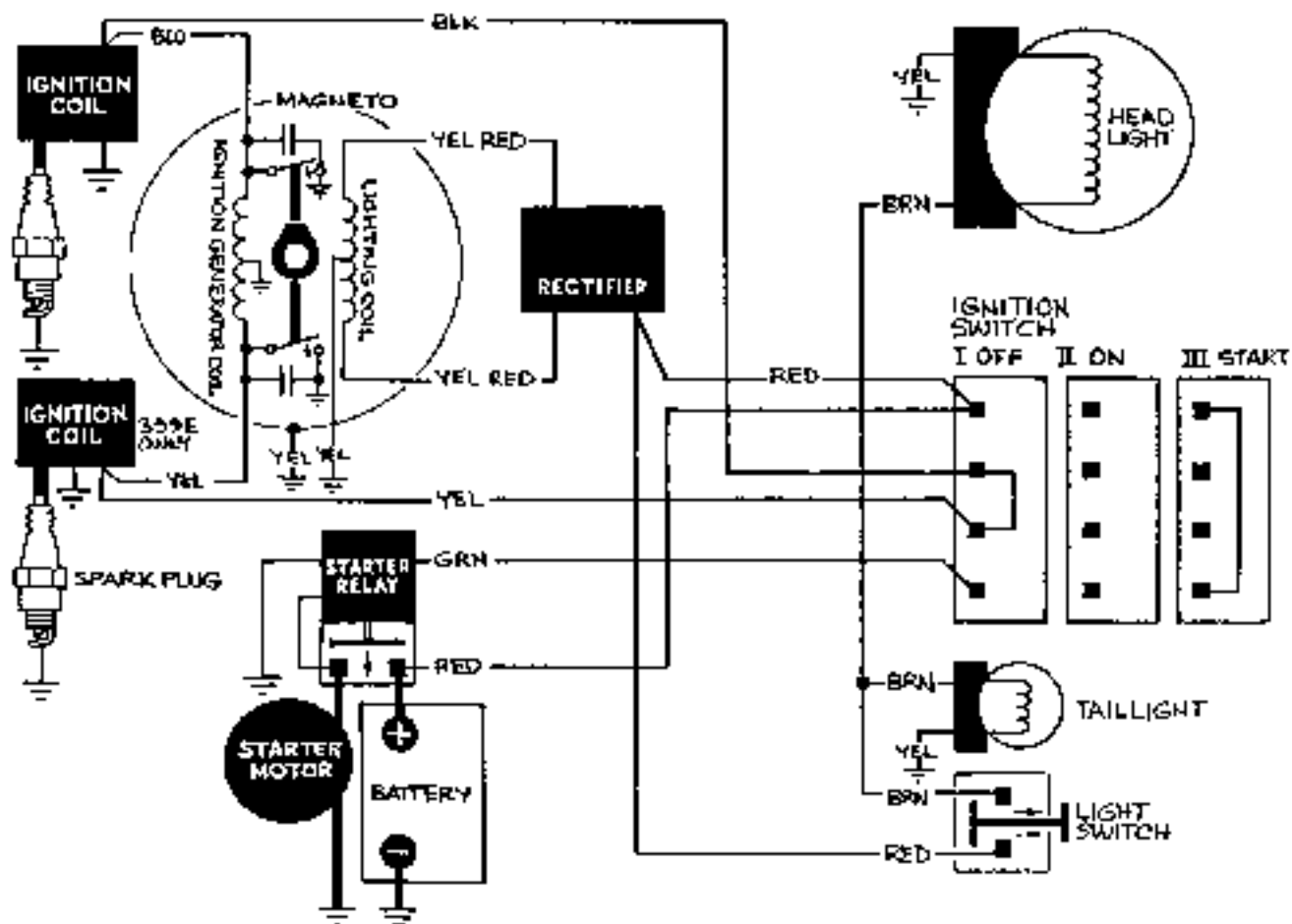

1972 OLYMPIQUE 335E, 399E, ELAN 250E

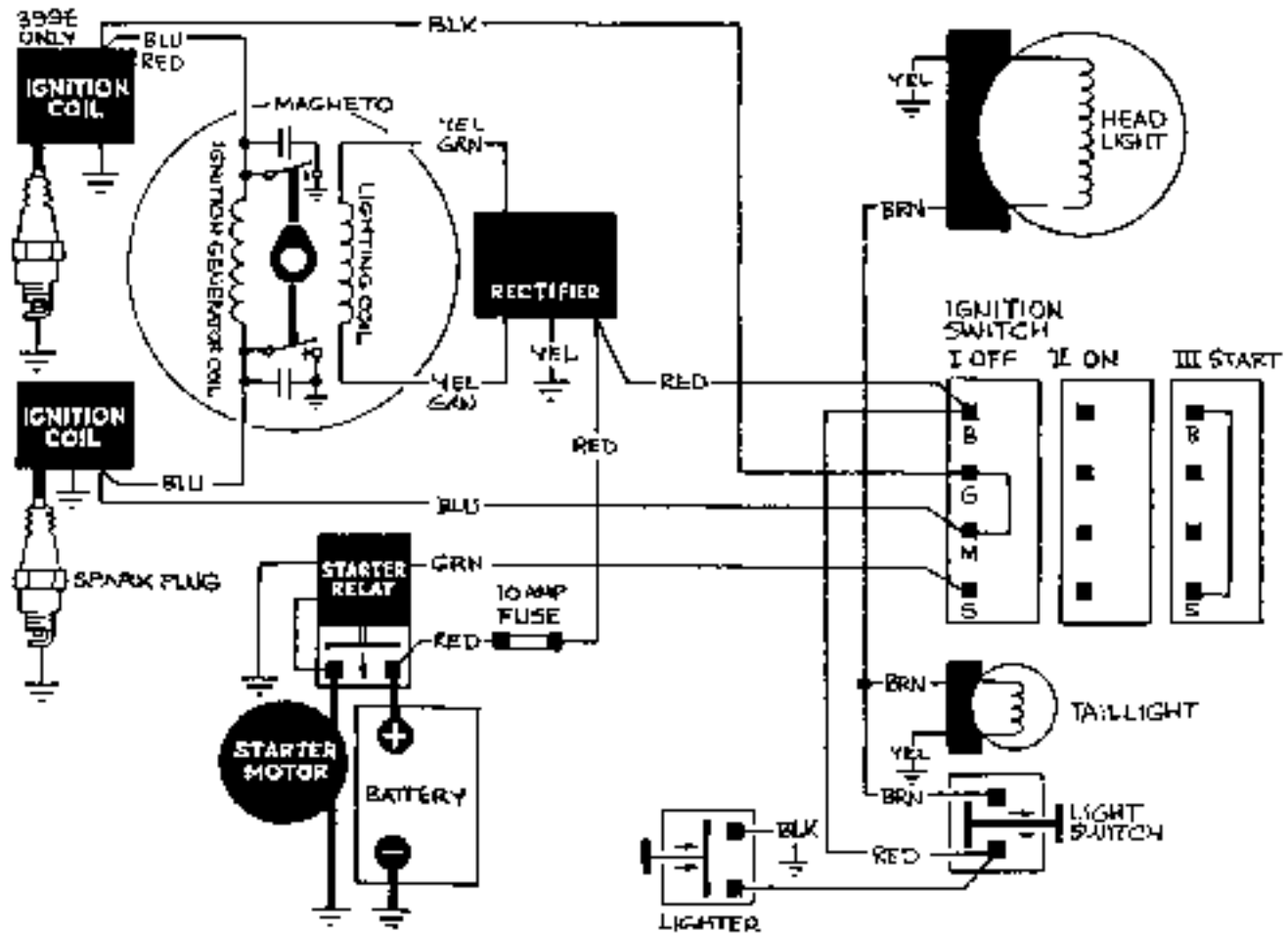

1972 OLYMPIQUE 399

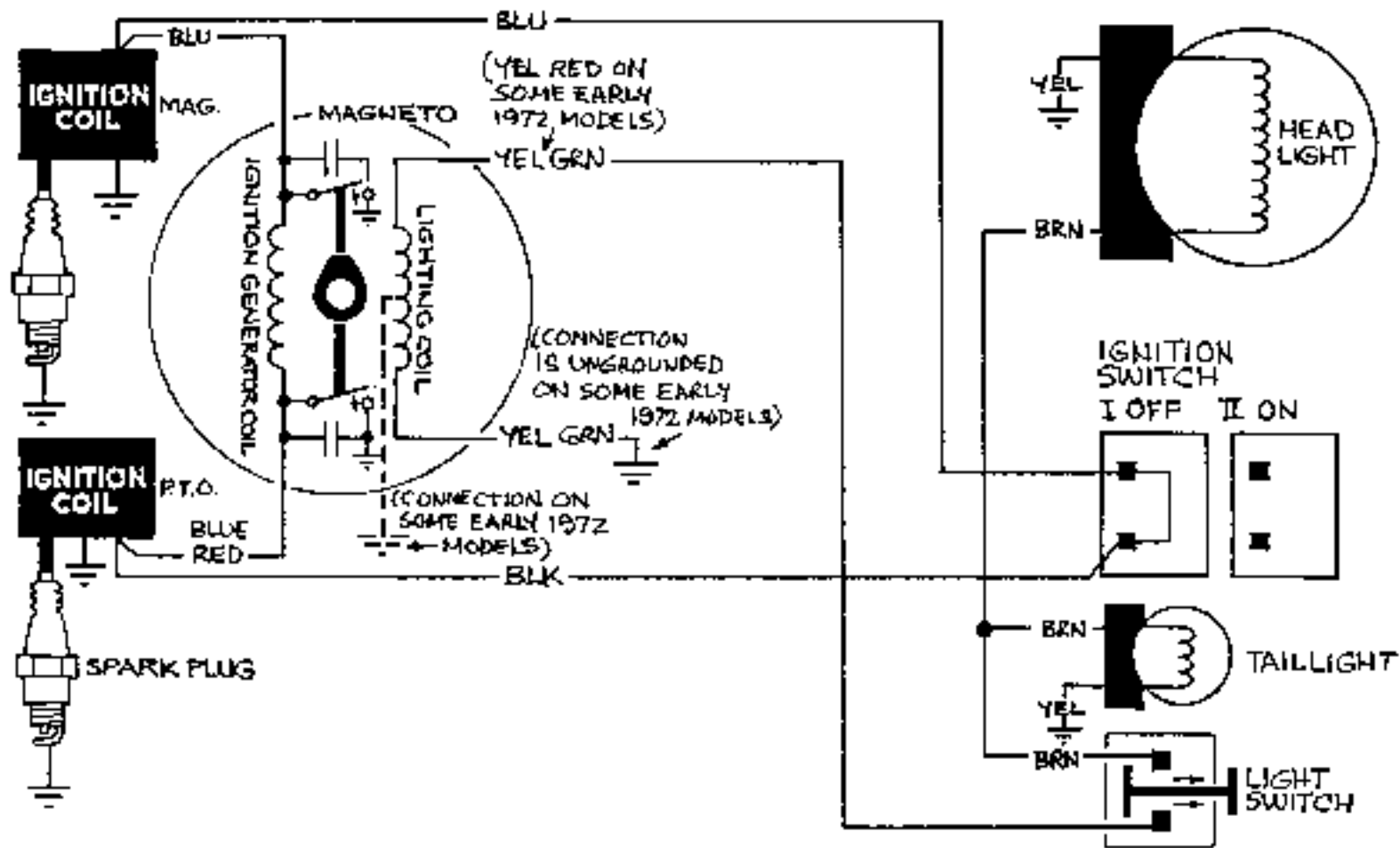

1972 T'NT 292, 340, 440

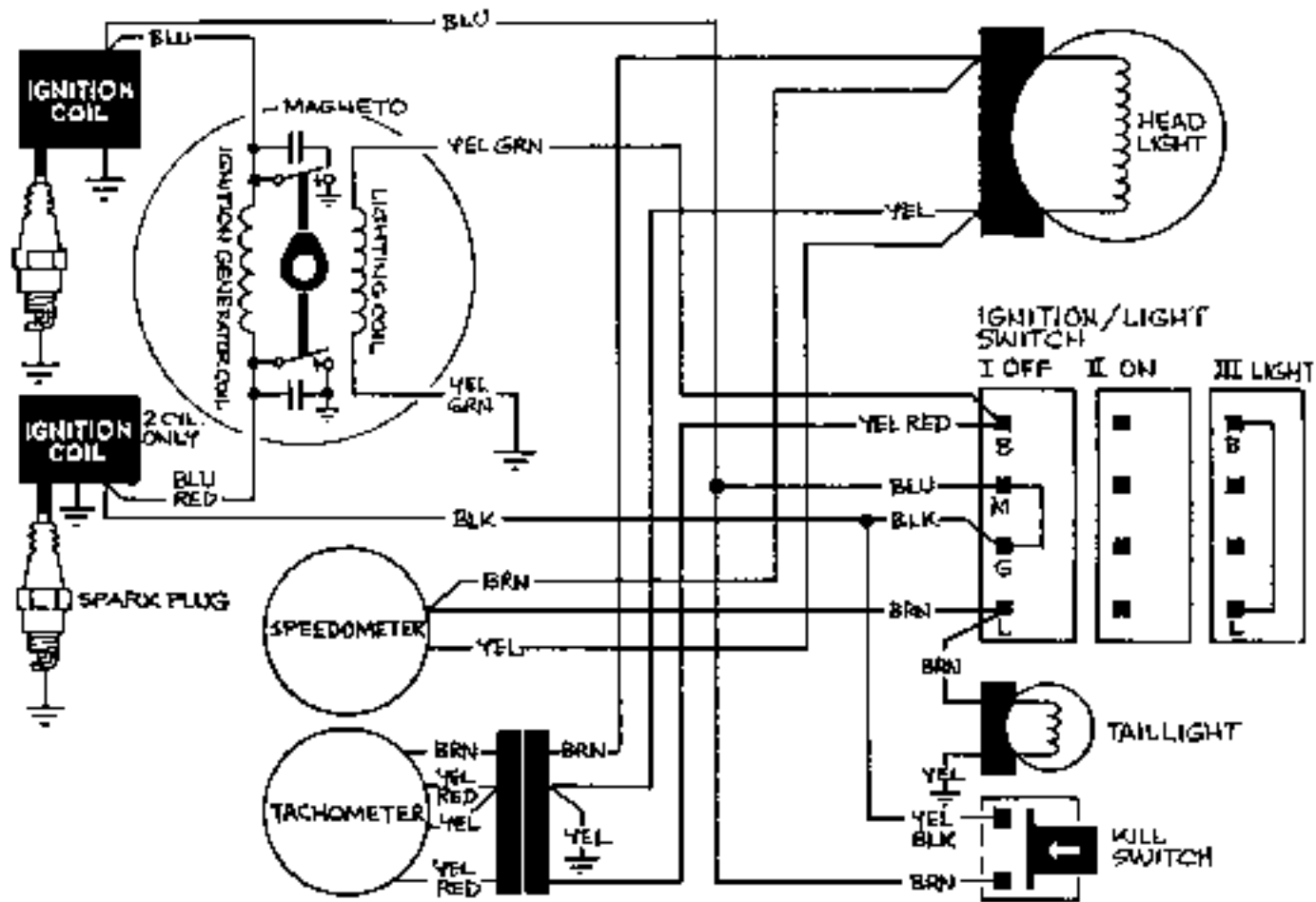

1973 ELAN 250E, OLYMPIQUE 340E-400E

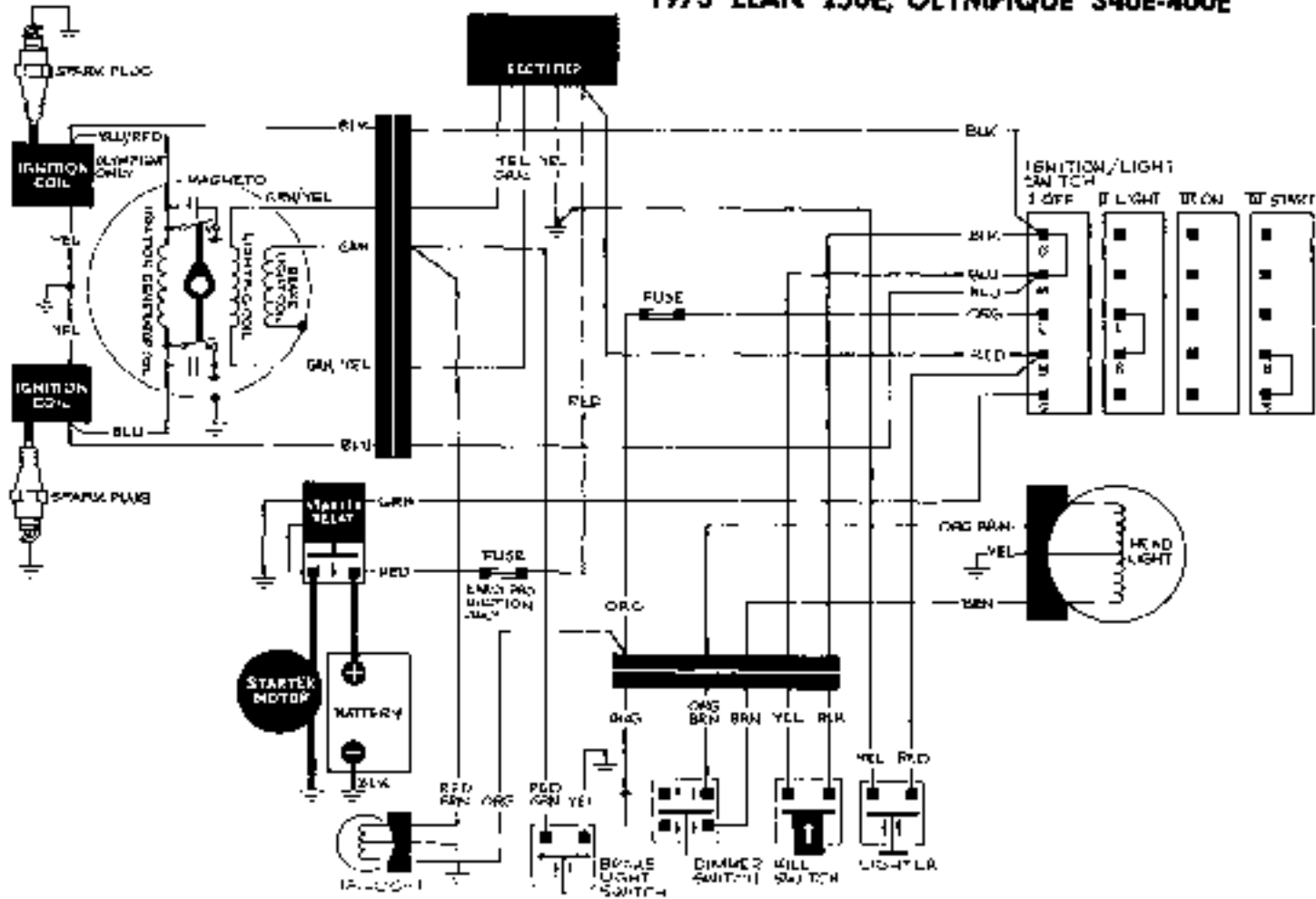

1973 ELAN 250T-25055, OLYMPIQUE 300-335

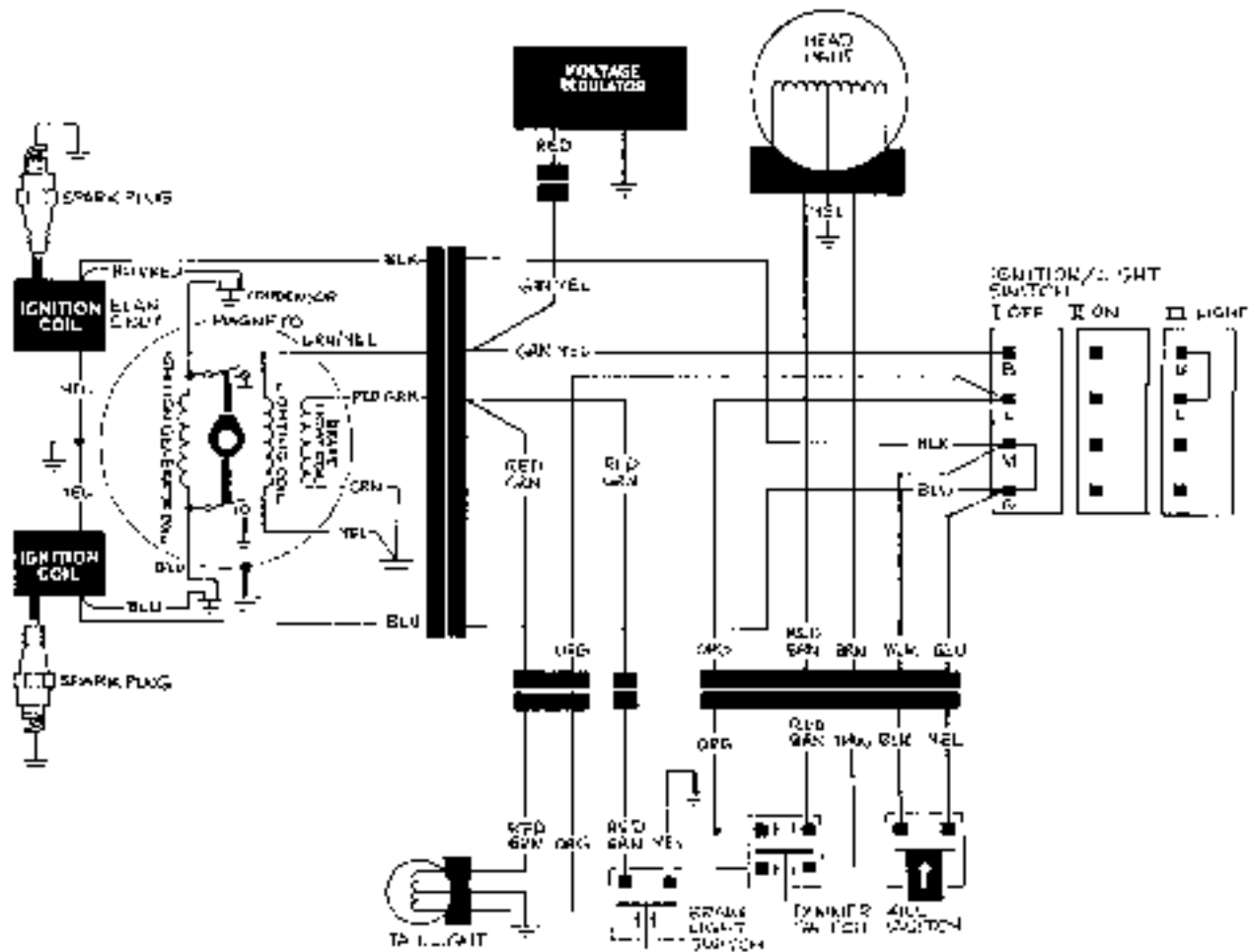

1973 OLYMPIQUE 340-400-440

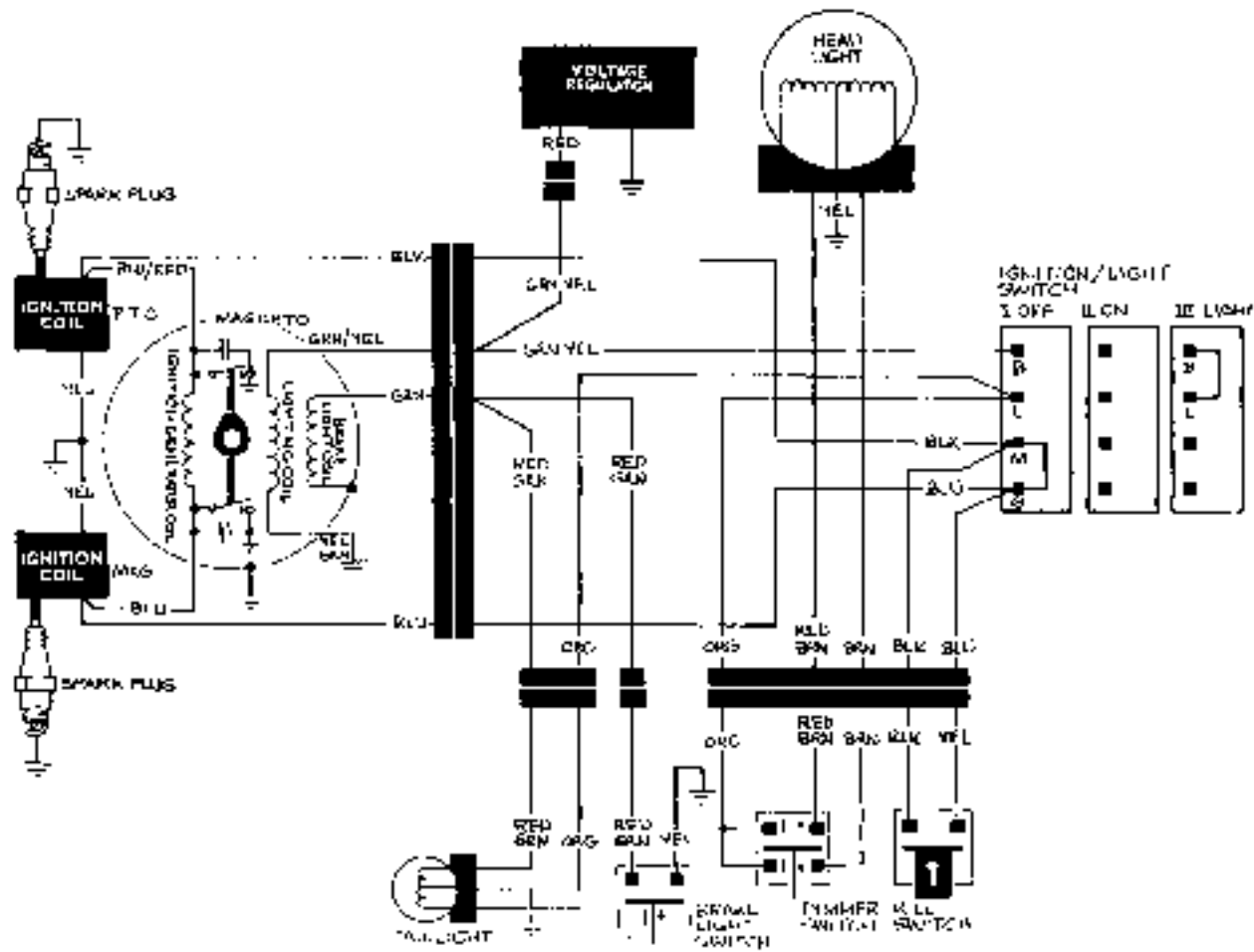

1973 T'NT 294, 340-440

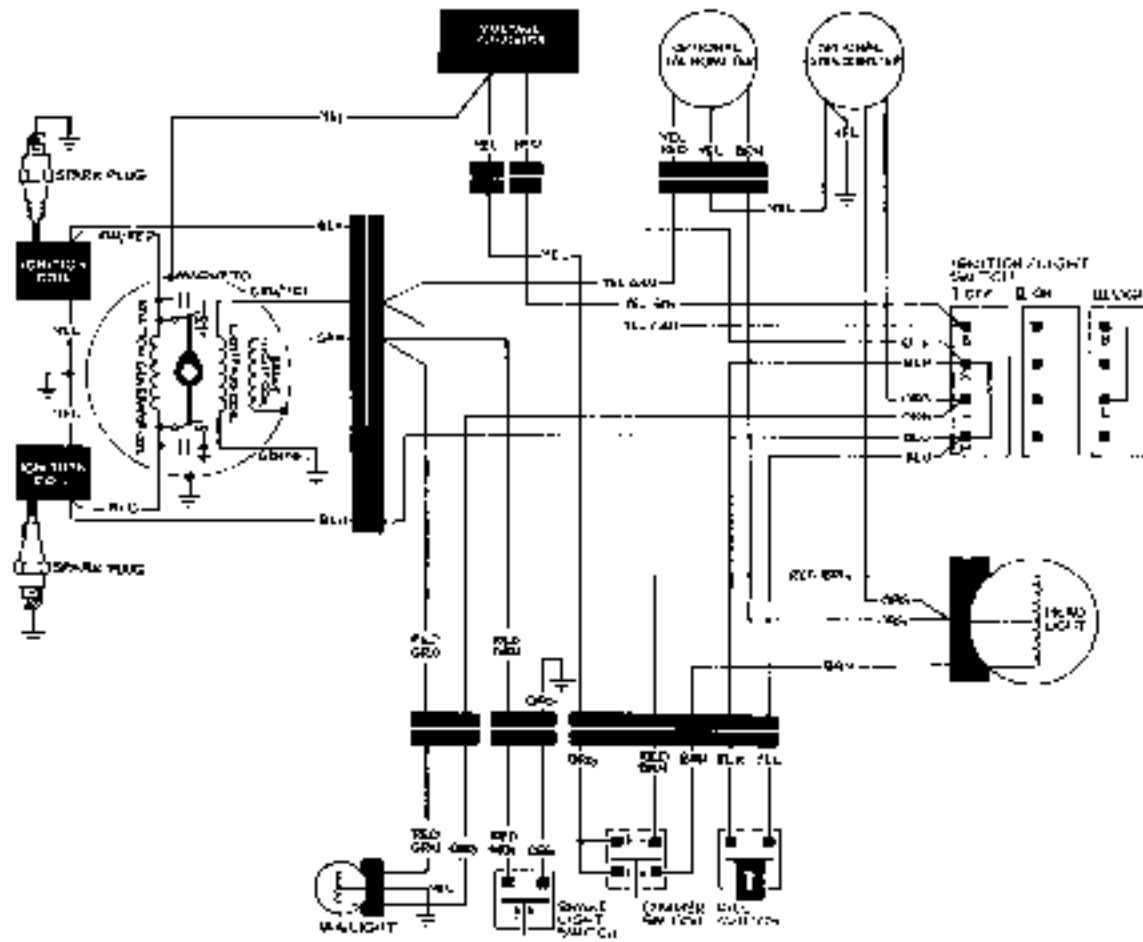

1973 TNT 340 F/A

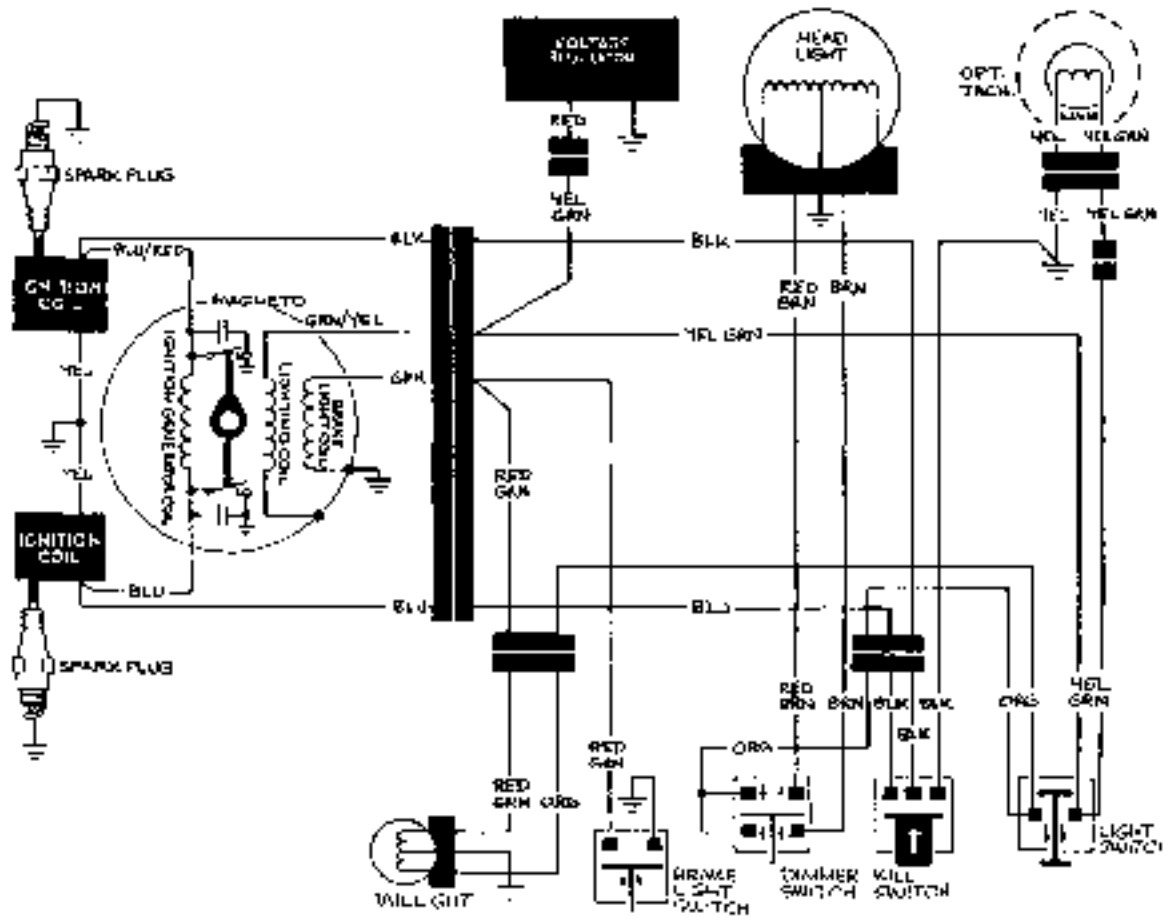

1973
1974
1975
1976
1977
1978
1979
1980
1981
1982
1983
1984
1985
1986
1987
1988
1989
1990
1991
1992
1993
1994
1995
1996
1997
1998
1999
2000

1973 T'NT 400 F/A

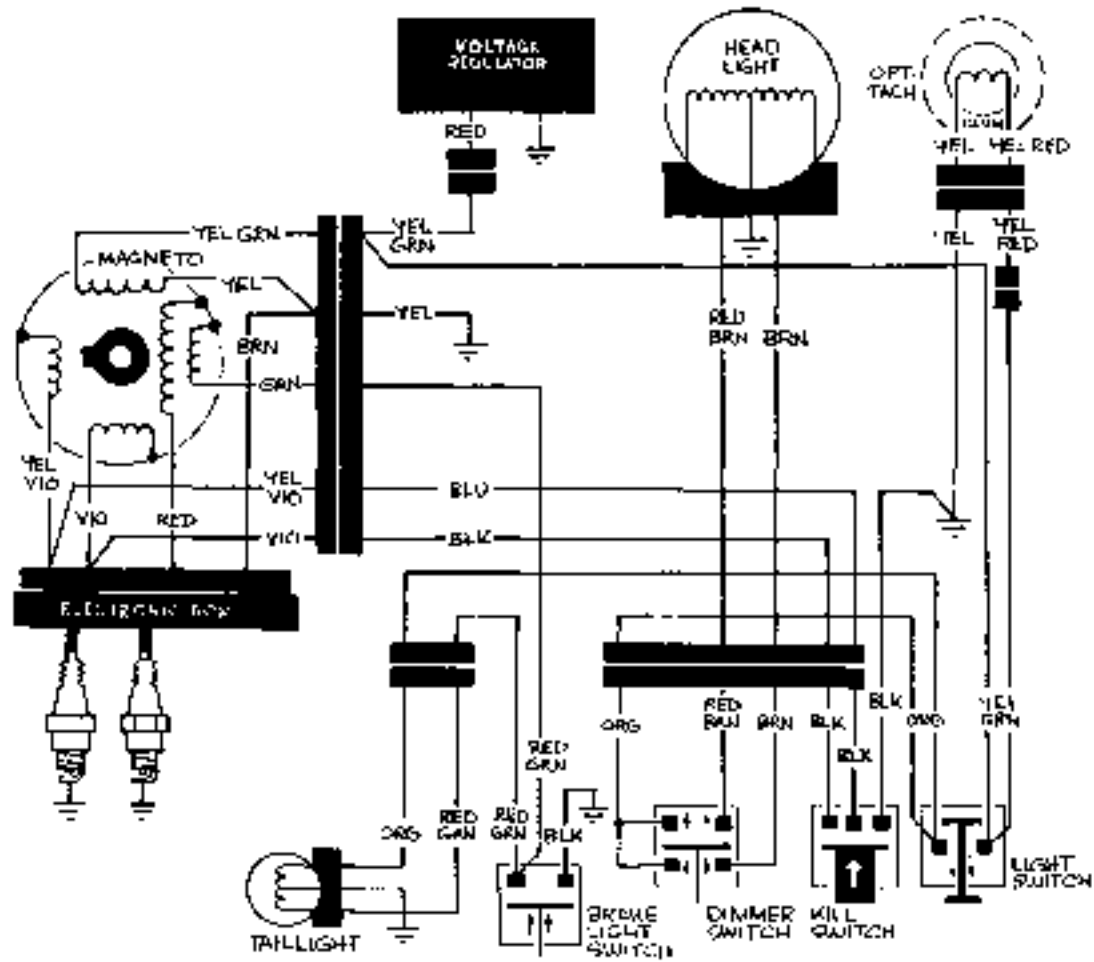

ELAN 250 (1974)

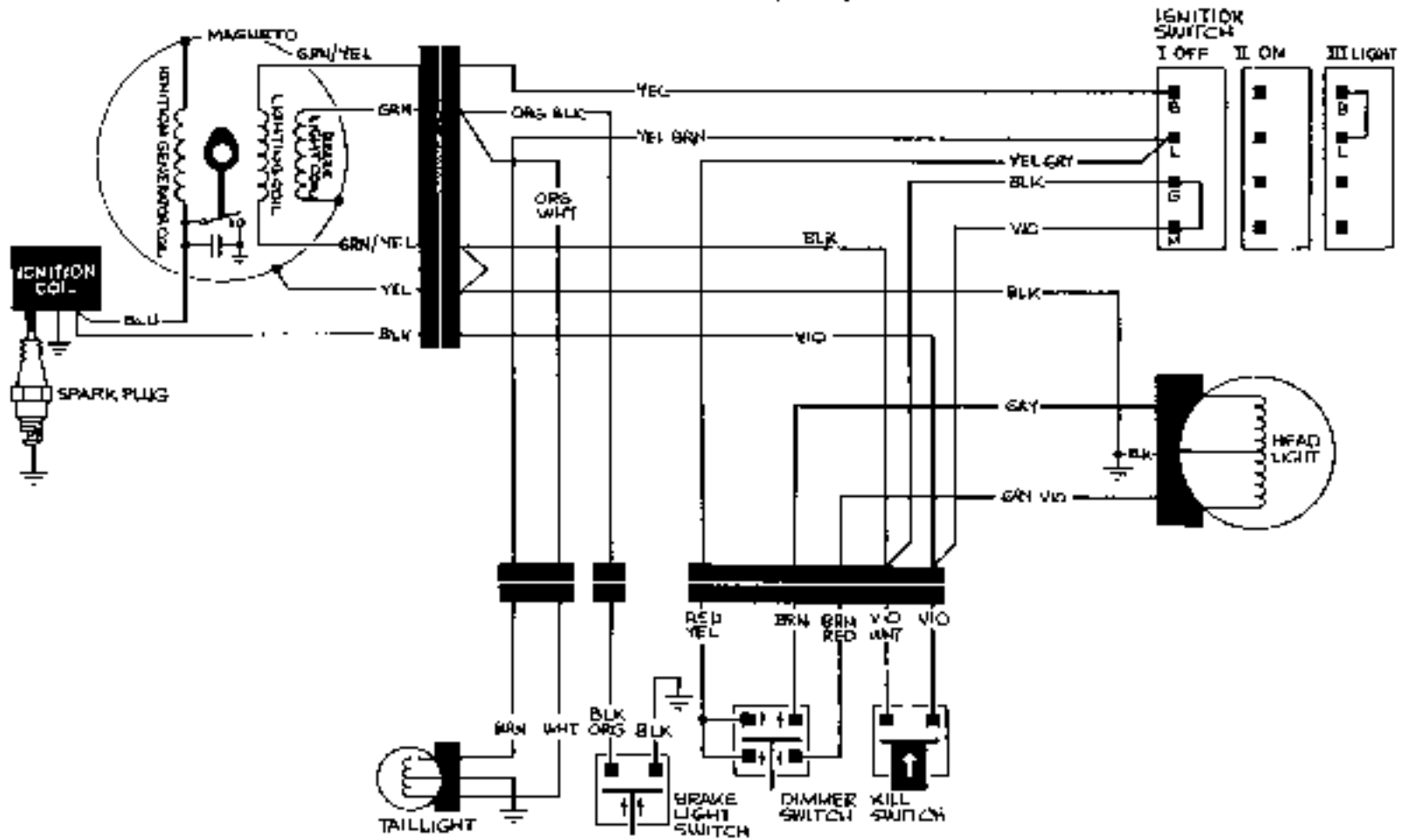

ELAN 250 DELUXE, 2945S (1974)

TNT 300SM (1974)

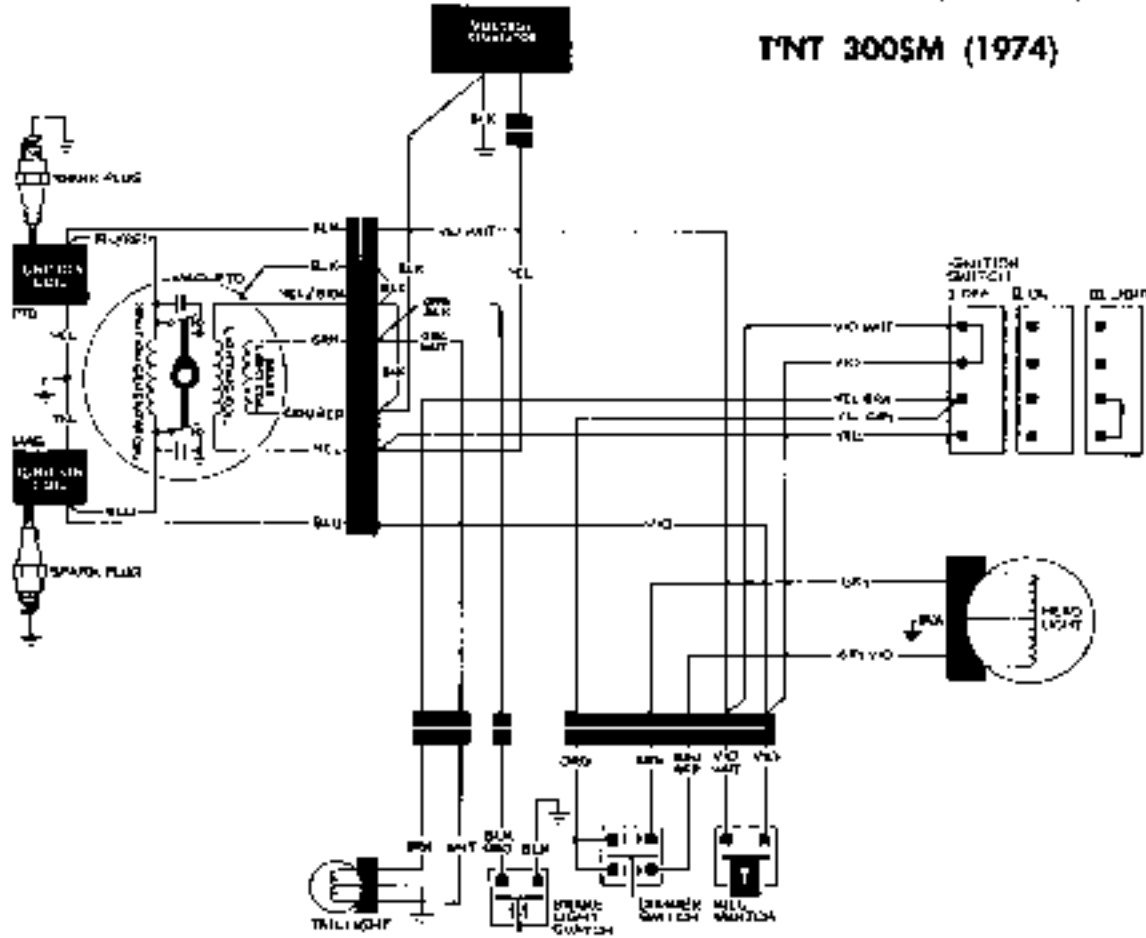

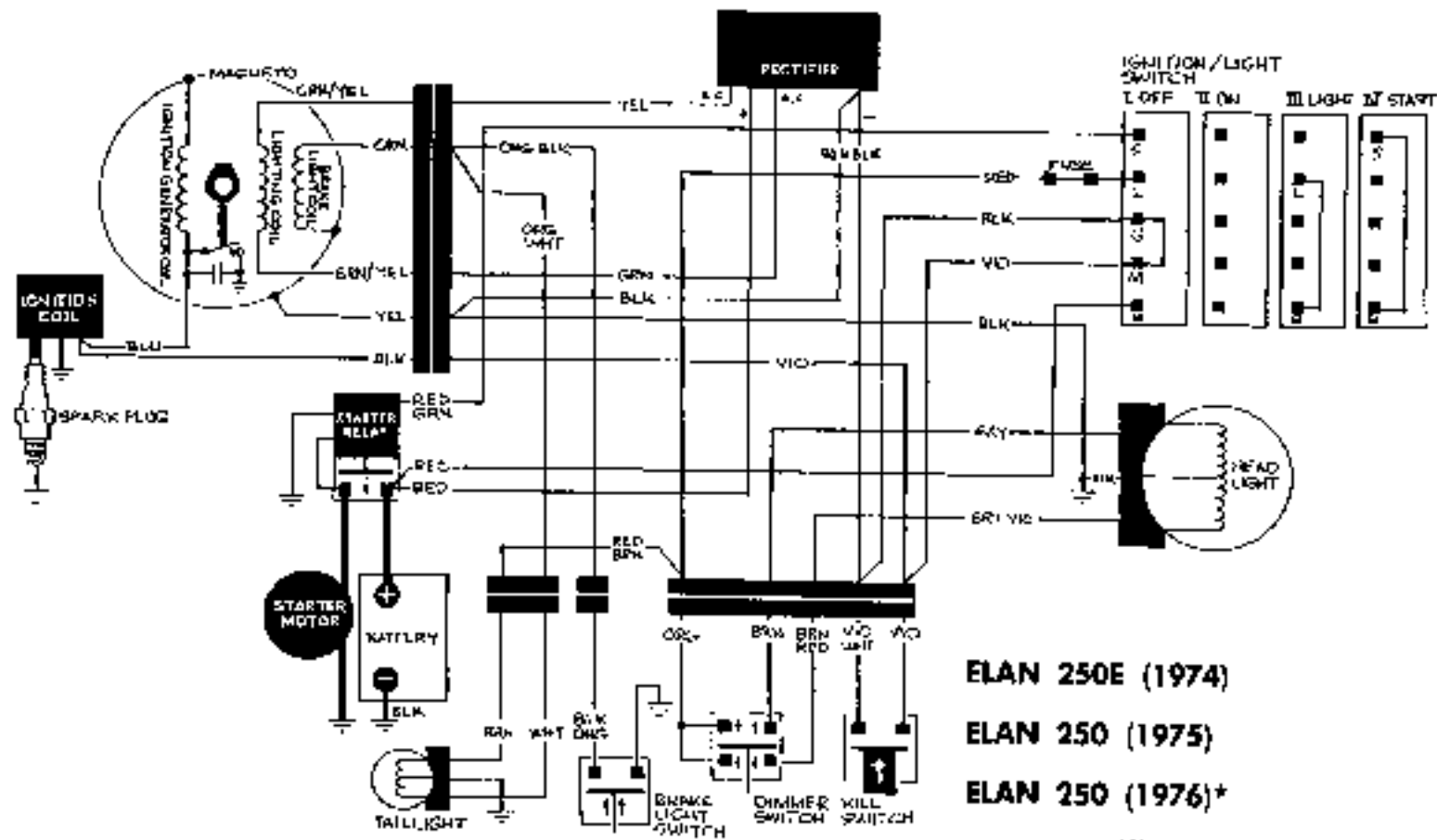

ELAN 250E (1974)

ELAN 250 (1975)

ELAN 250 (1976)*

*Up to serial number 3013 0399

OLYMPIQUE 300 (1974)



OLYMPIQUE 300 (1974)

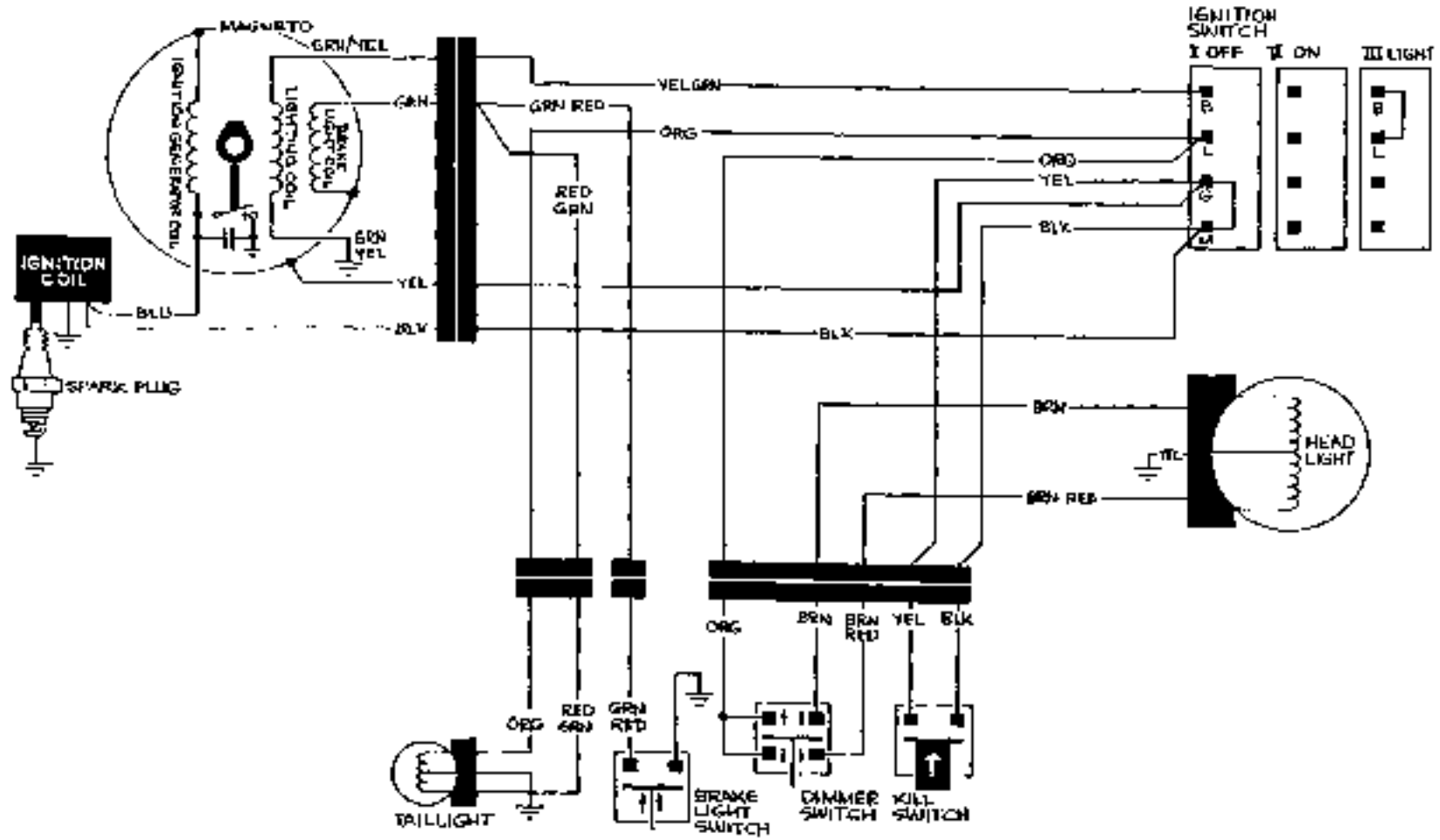

OLYMPIQUE 340, 400, 440 (1974)

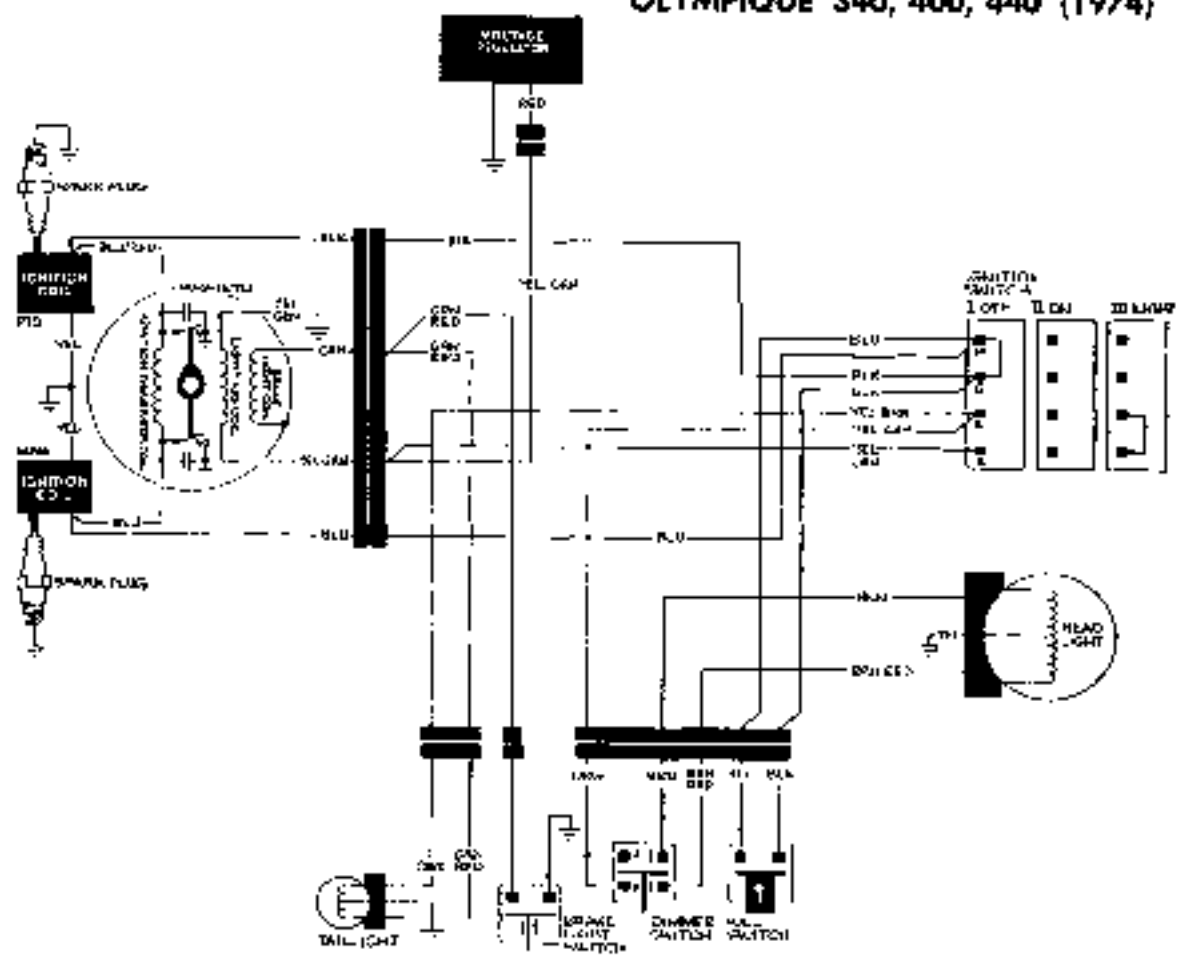

OLYMPIQUE 340E, 440E (1974)

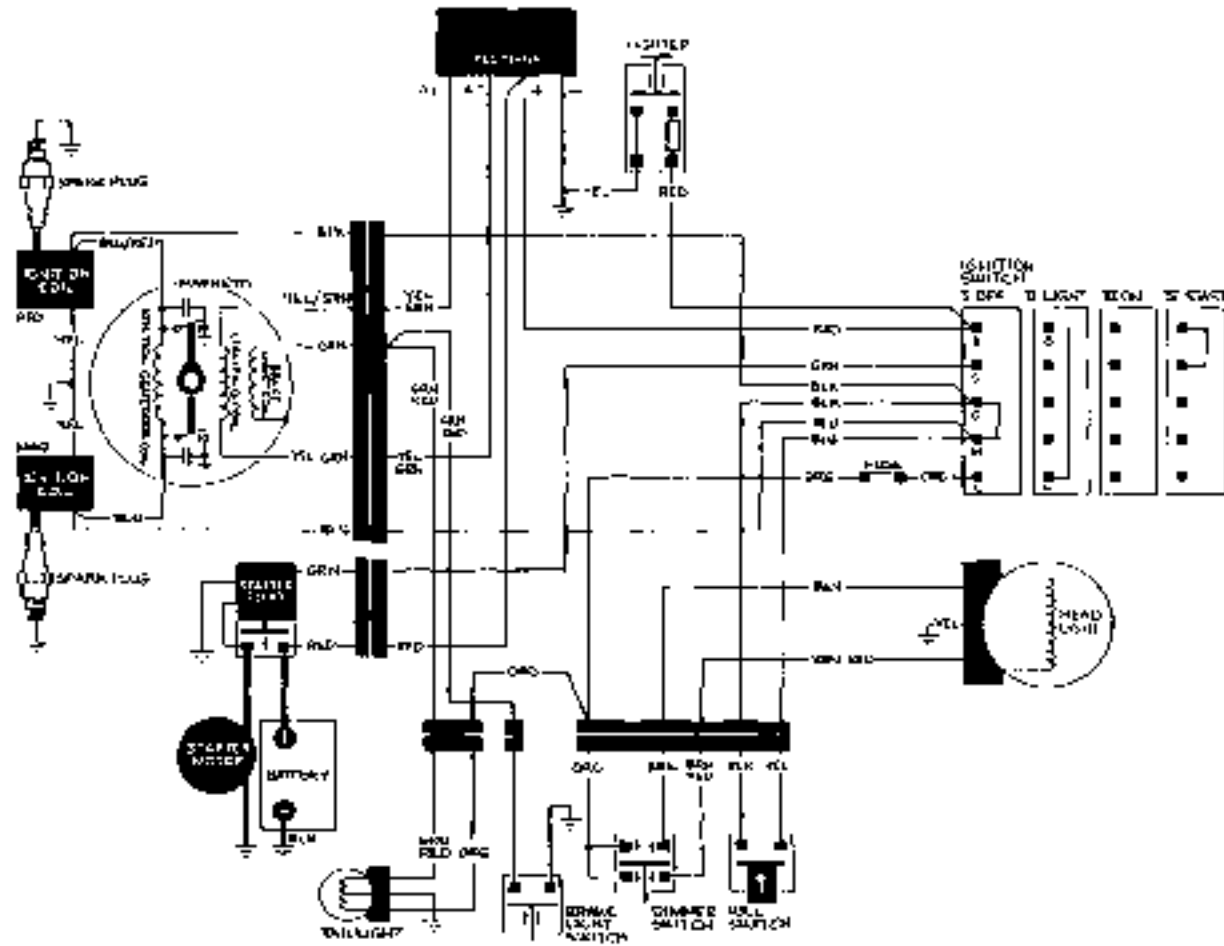

TNT 340SE, 440SE (1974)

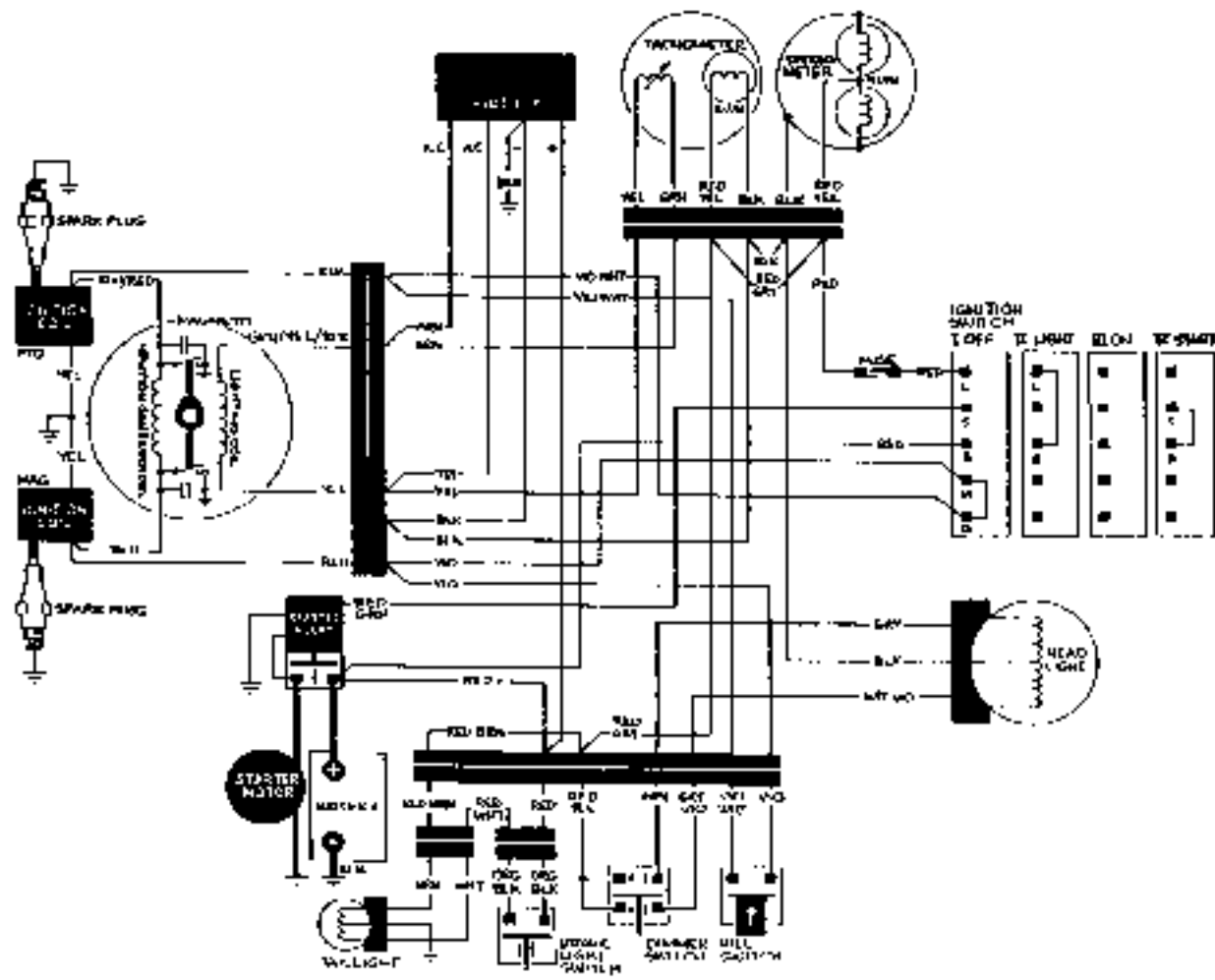

**TNT 340SM, 440SM,
EVEREST (1974)**

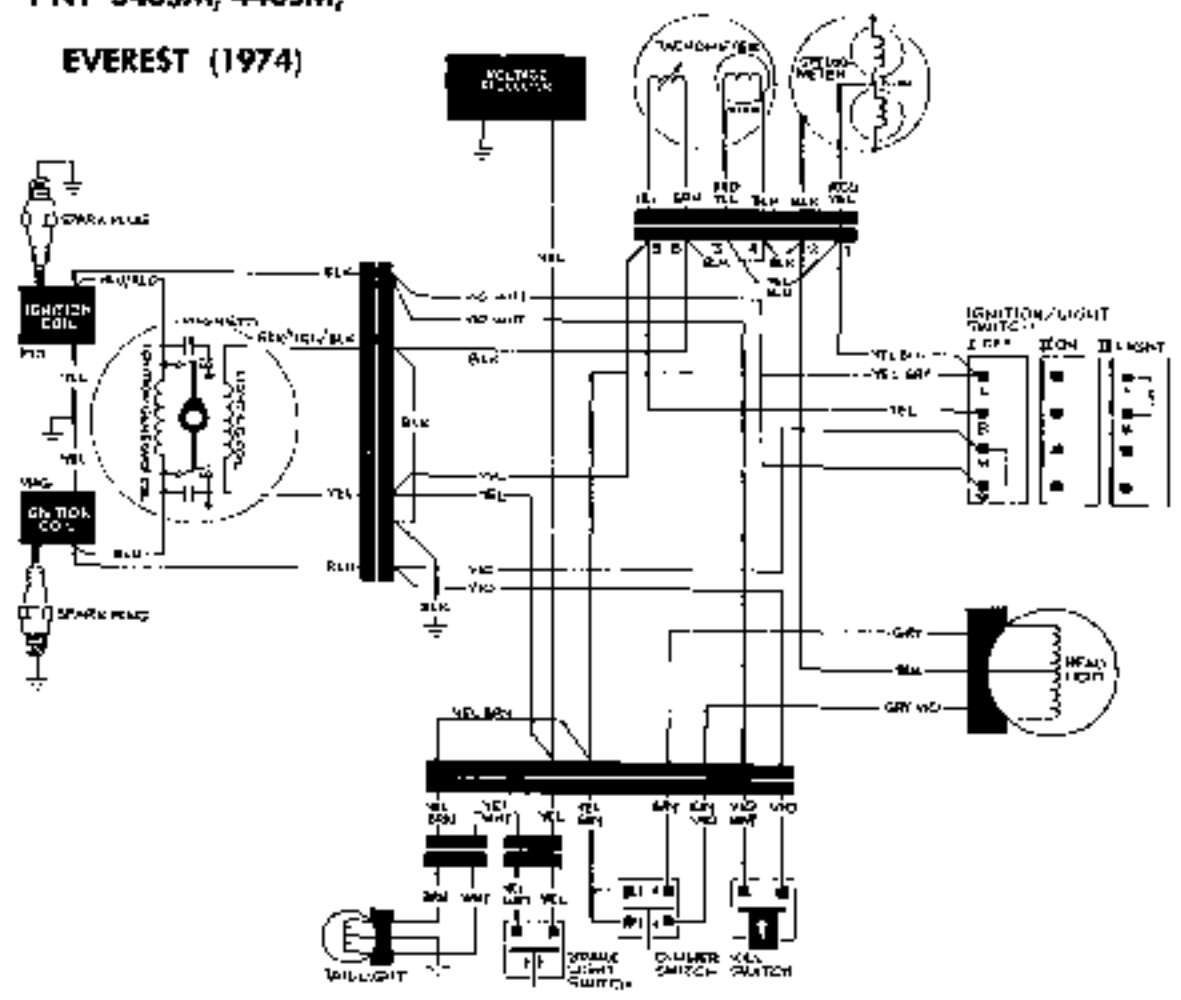

T'NT F/A 340, 400, 440 (1974)

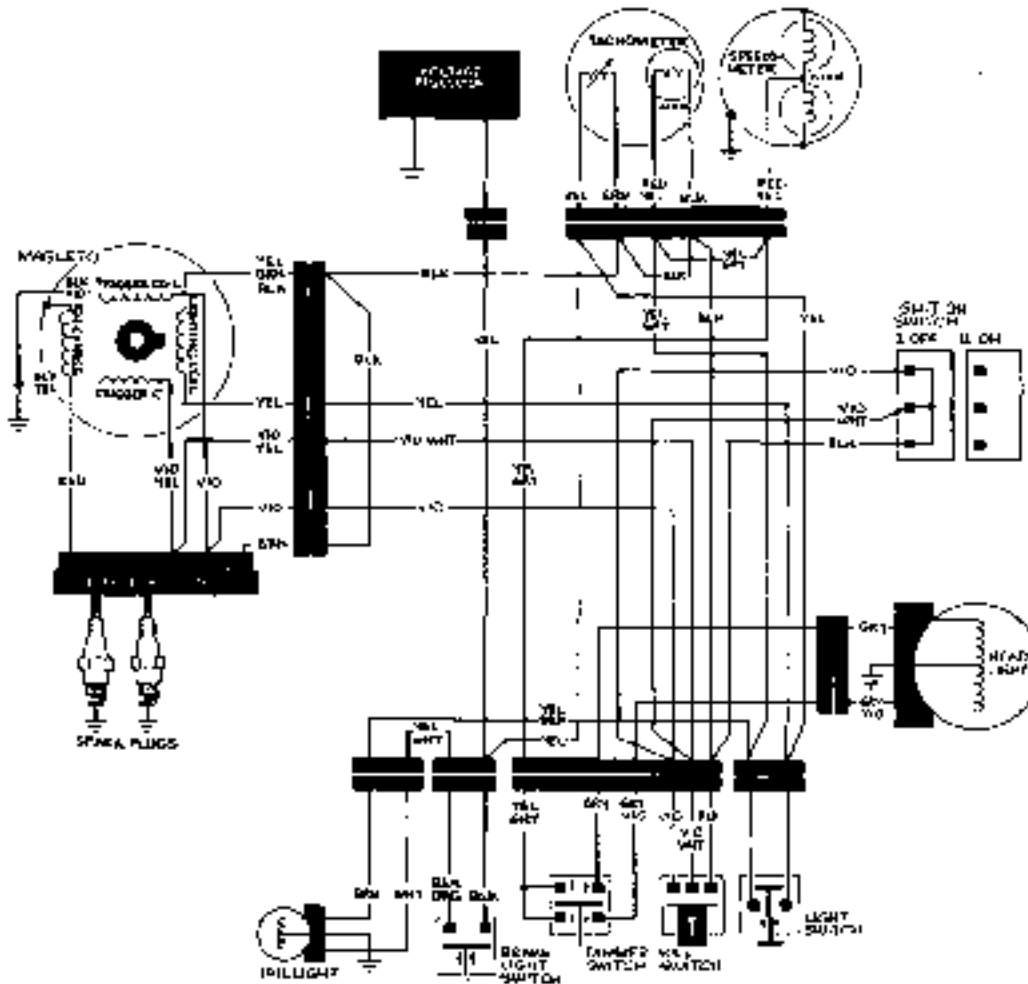

1974
 1975
 1976
 1977
 1978
 1979
 1980
 1981
 1982
 1983
 1984
 1985
 1986
 1987
 1988
 1989
 1990
 1991
 1992
 1993
 1994
 1995
 1996
 1997
 1998
 1999
 2000

ELAN 250 DELUXE, 300SS (1975)

ELAN 250 DELUXE (1976-1977)

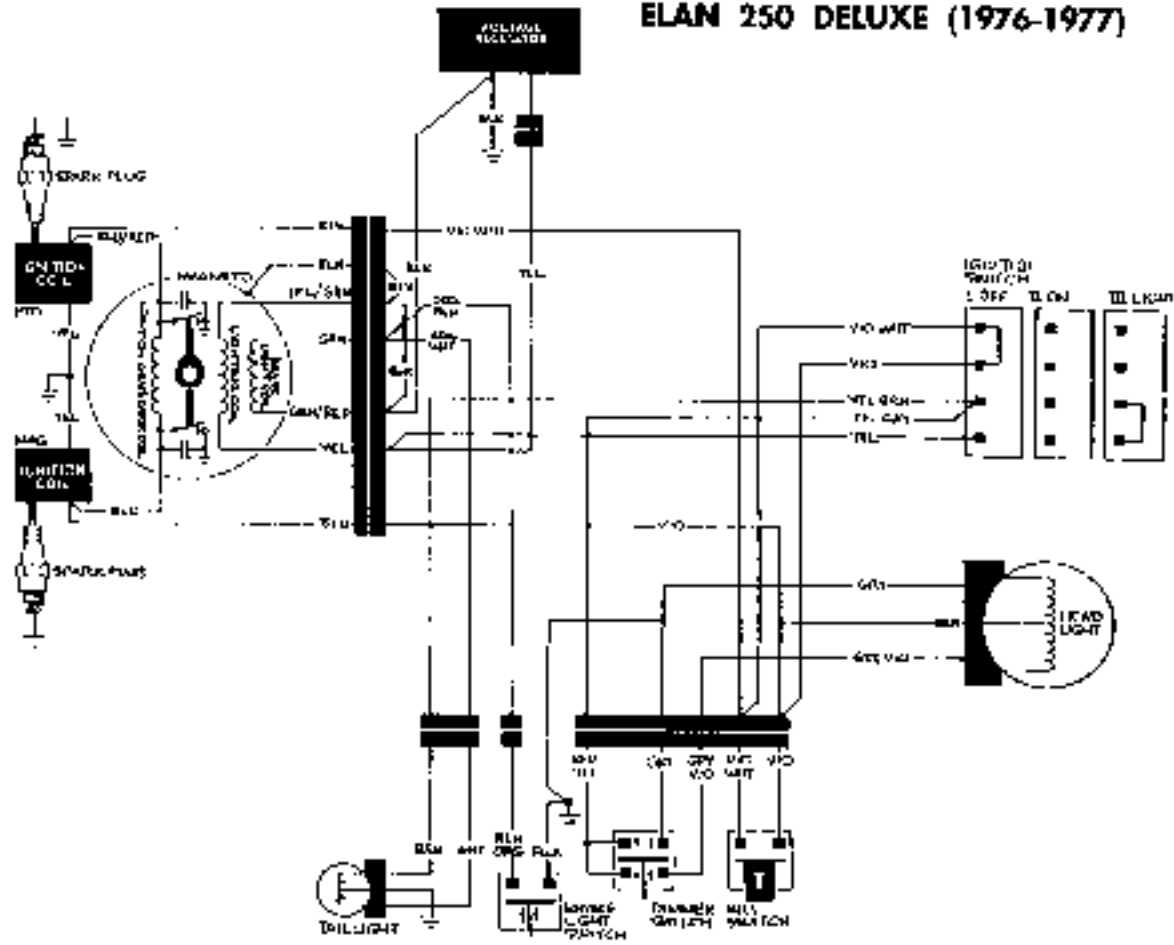

OLYMPIQUE 300, 340 (1975-1977)

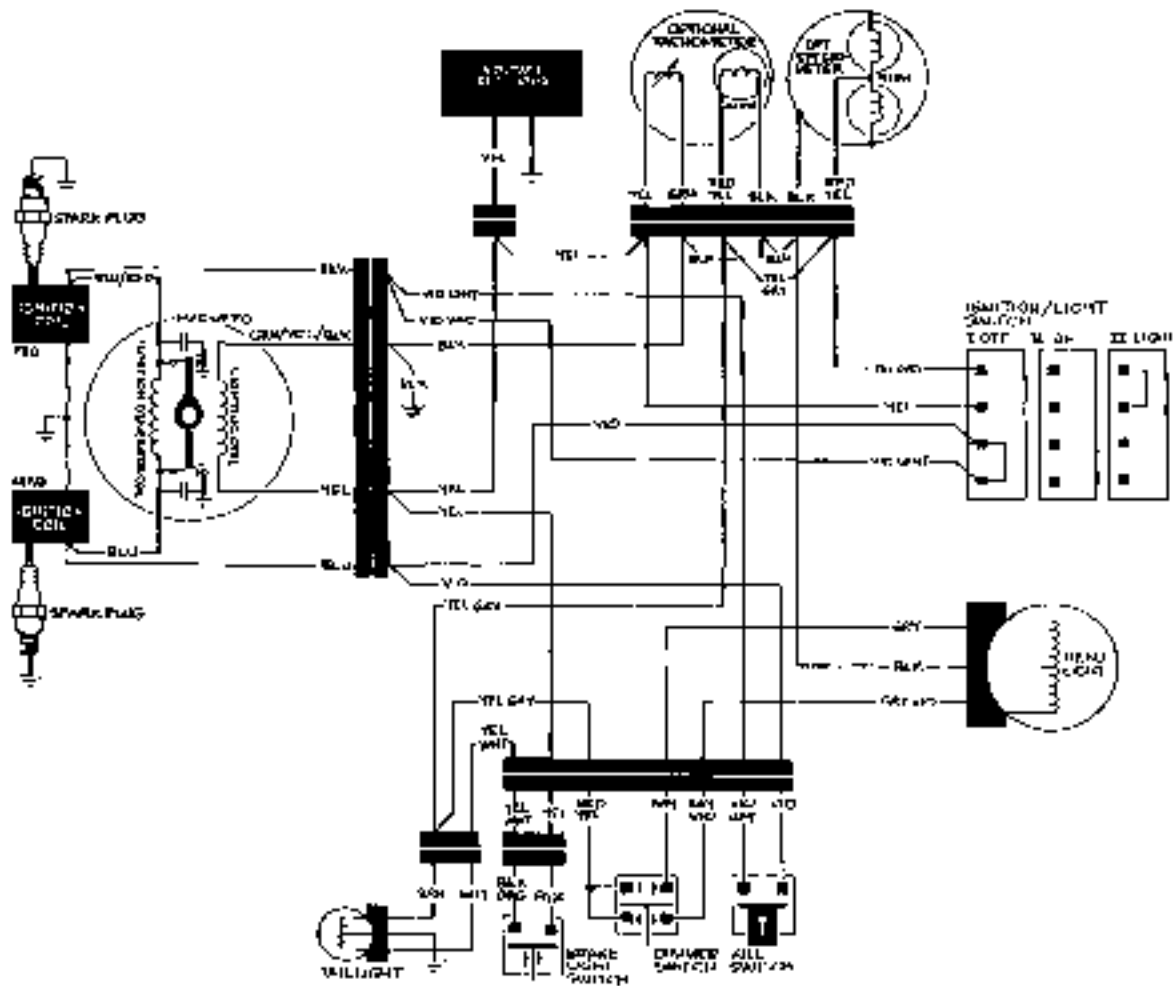

OLYMPIQUE 300E, 340E (1975-1977)

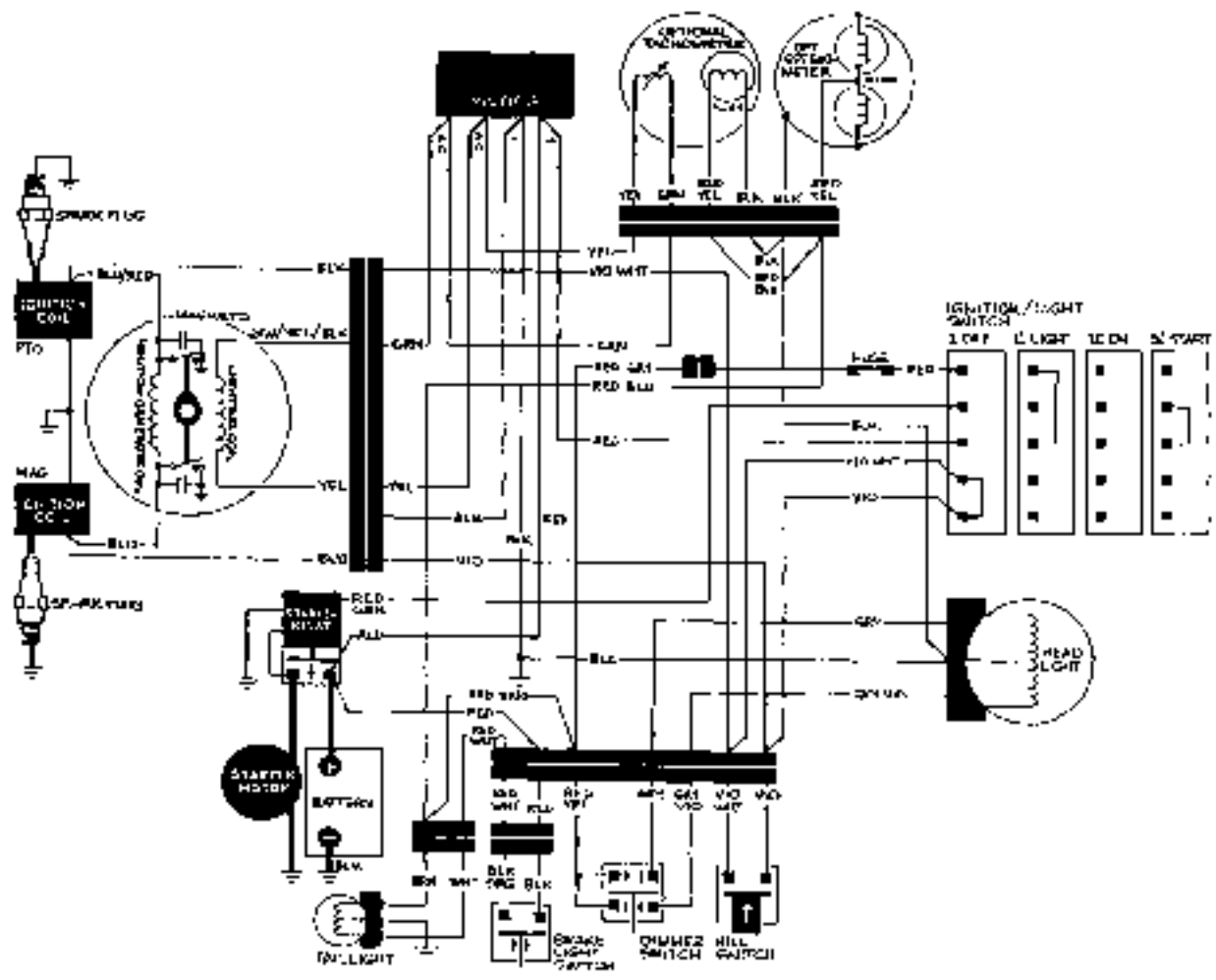

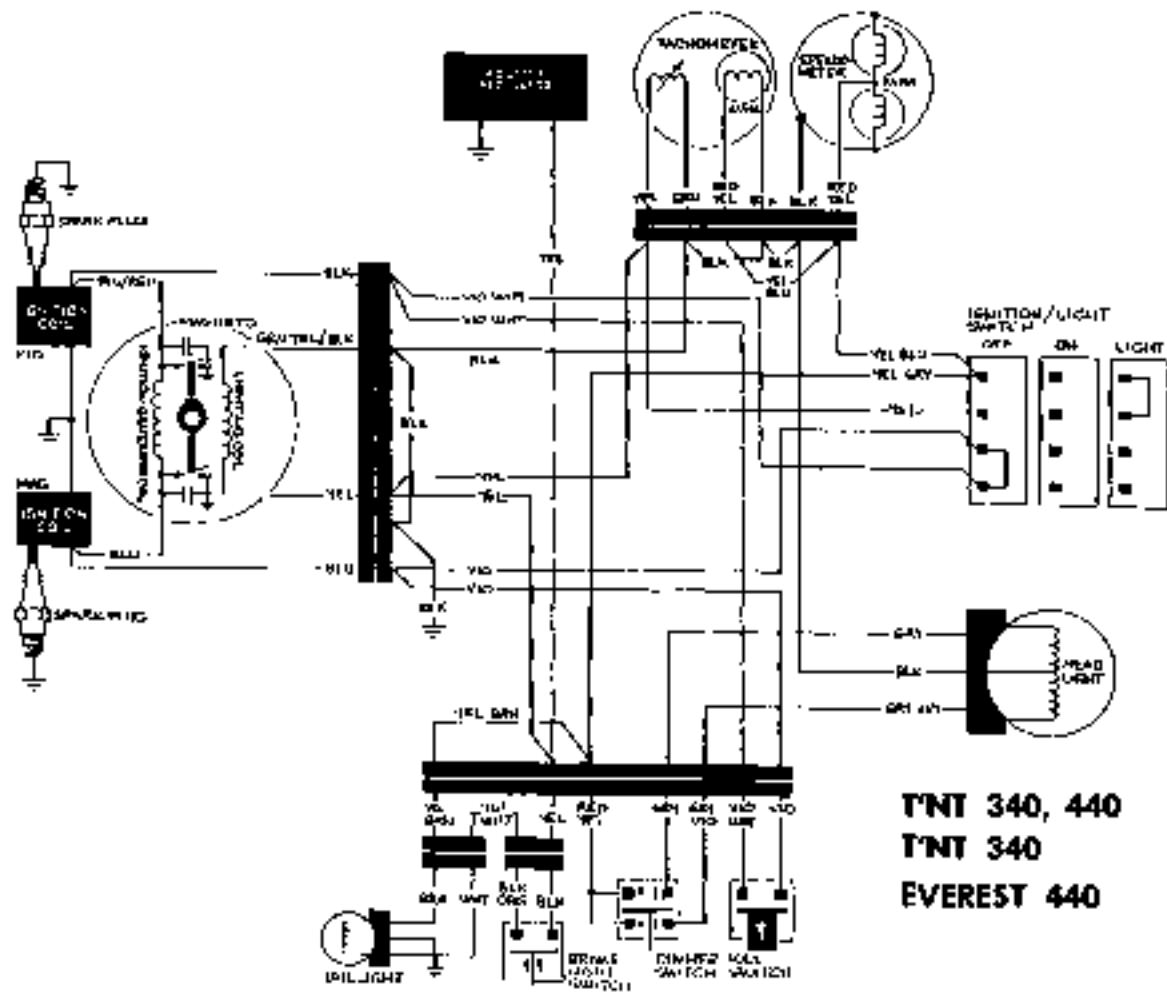

TNT 340, 440 (1975)
TNT 340 (1976-1977)
EVEREST 440 (1976-1977)



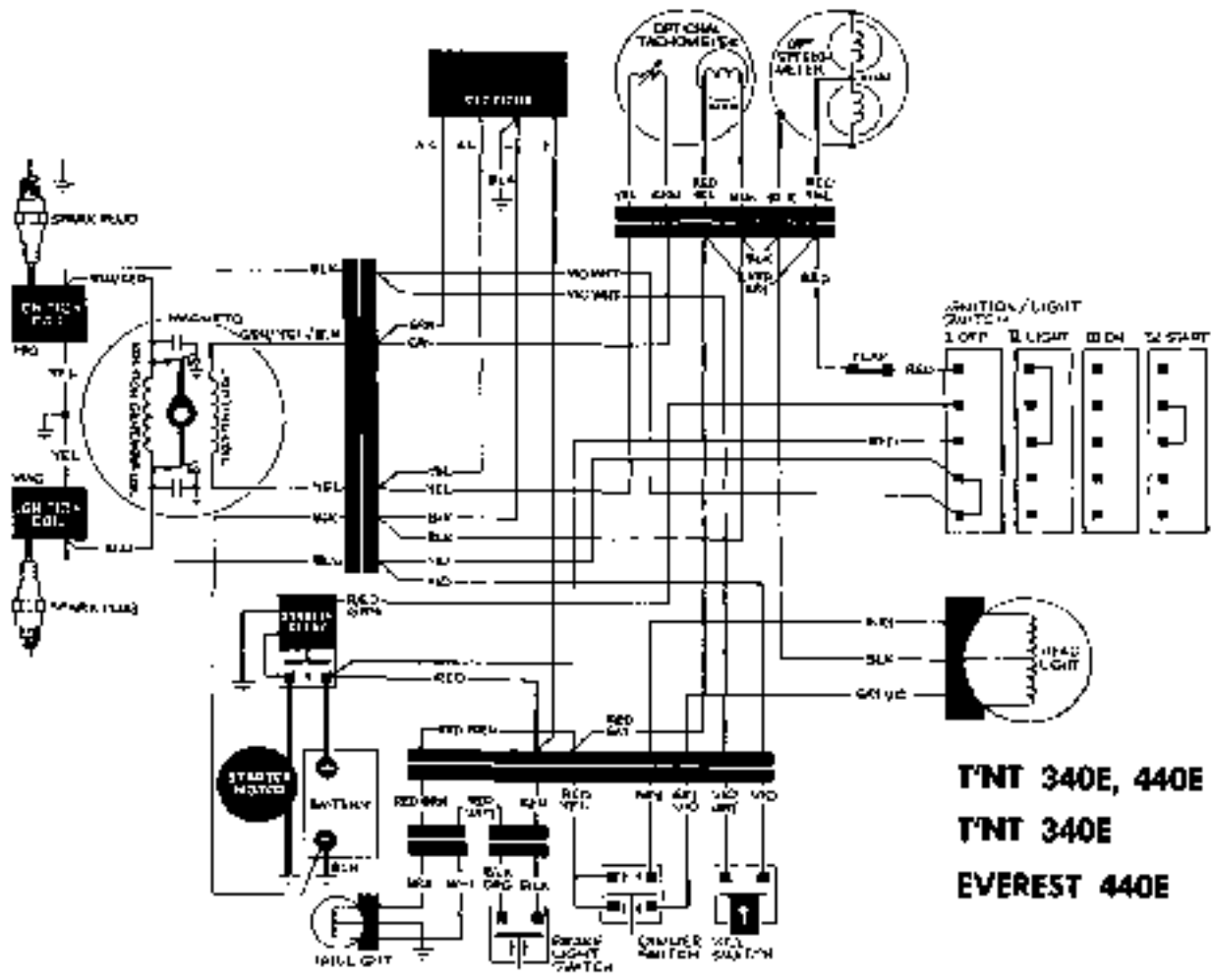

T'NT EVEREST 440 (1975)

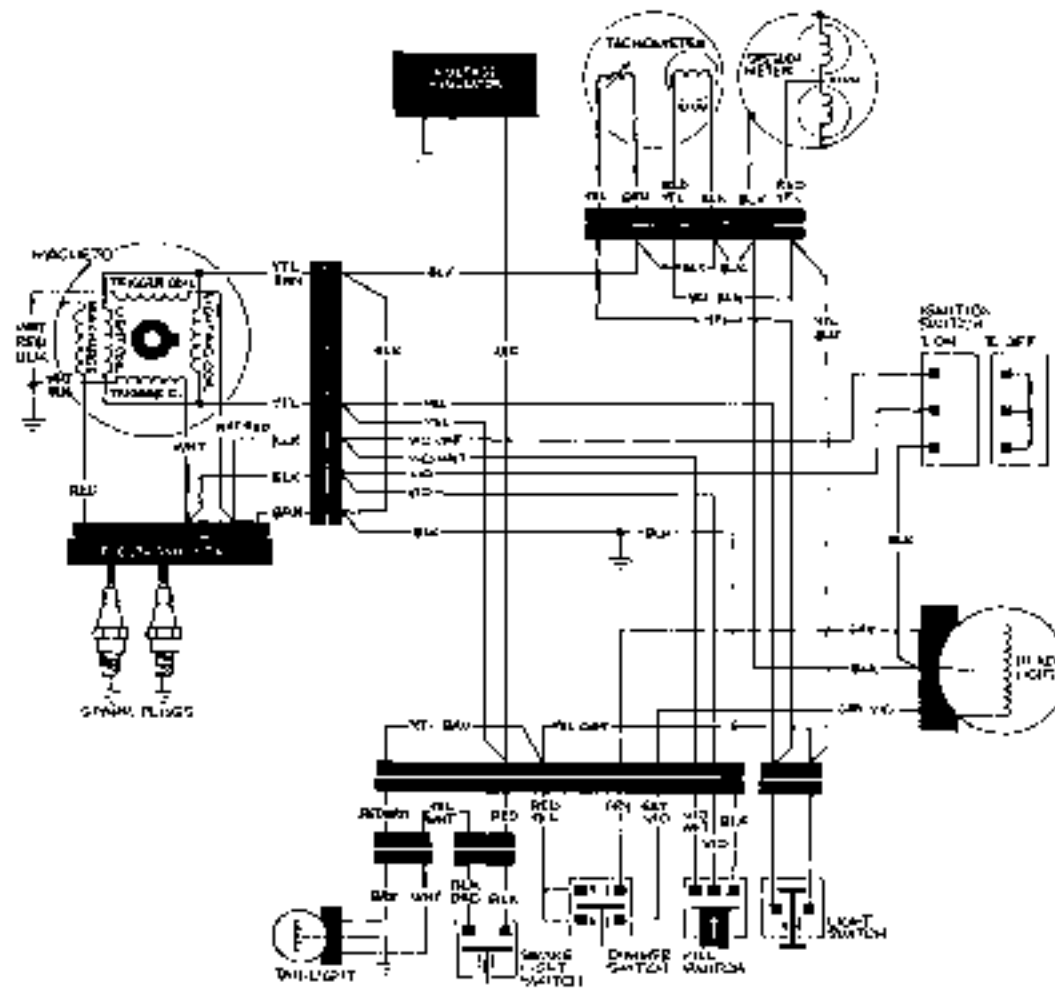

123456789
 1011121314151617181920
 21222324252627282930
 31323334353637383940
 41424344454647484950
 51525354555657585960
 61626364656667686970
 71727374757677787980
 81828384858687888990
 919293949596979899100

TNT EVEREST 440E (1975)

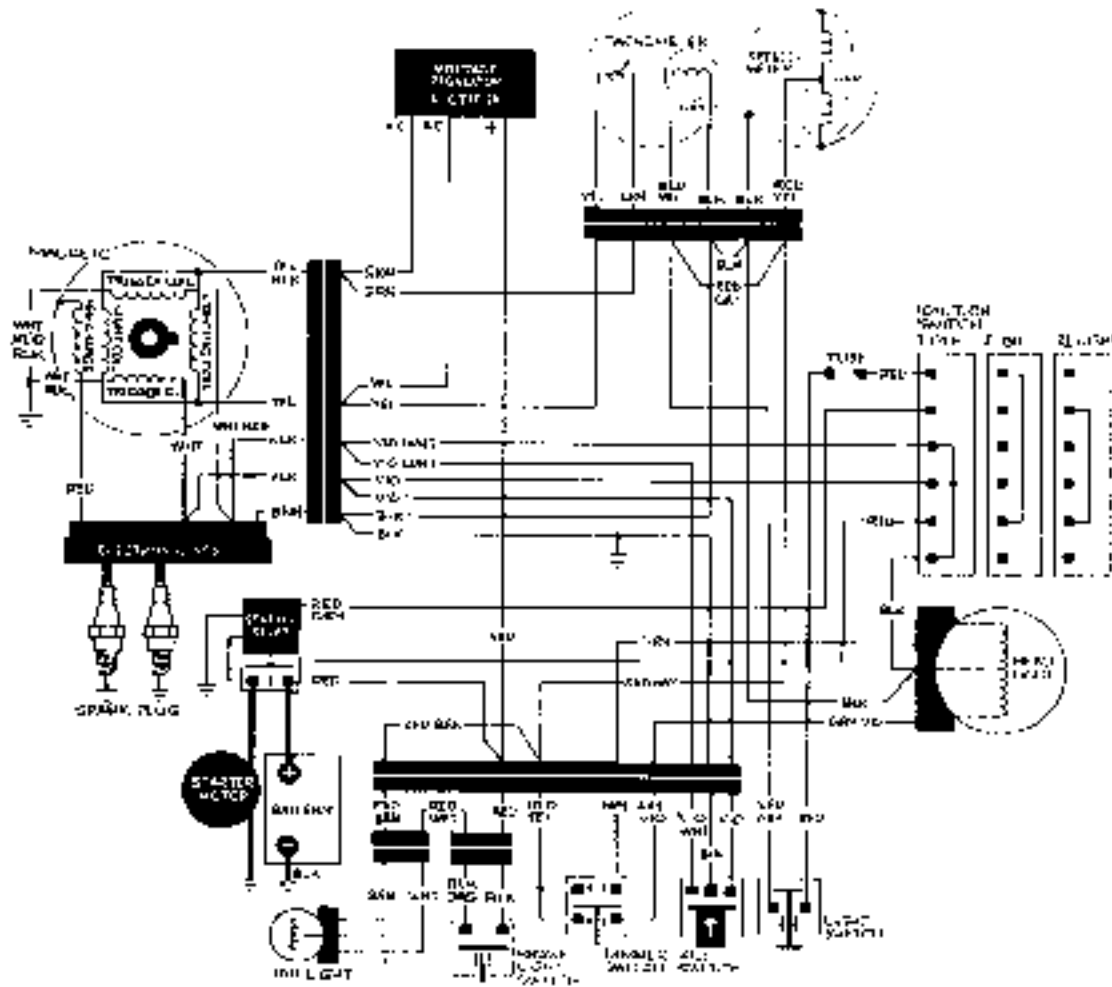

TNT F/A 340, 440 (1975)

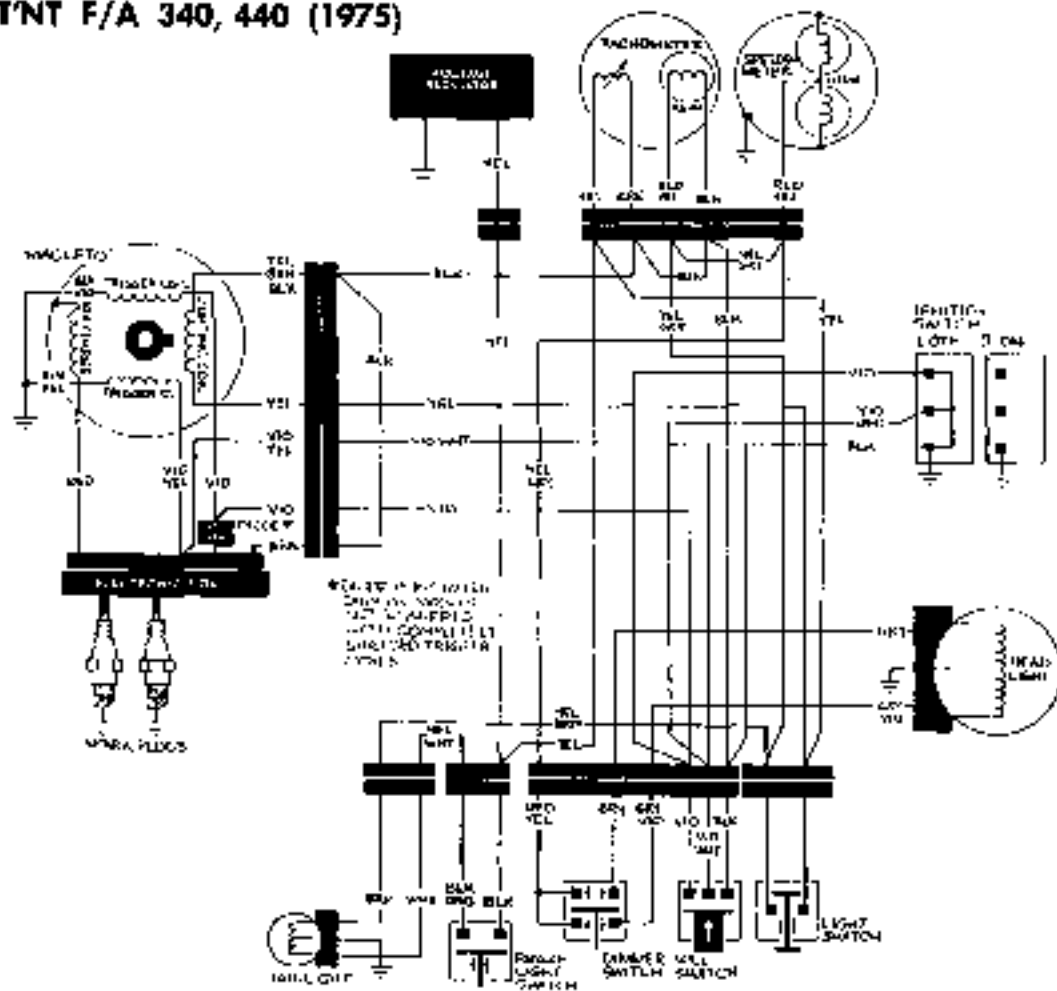

TNT R/V 245 (1975)

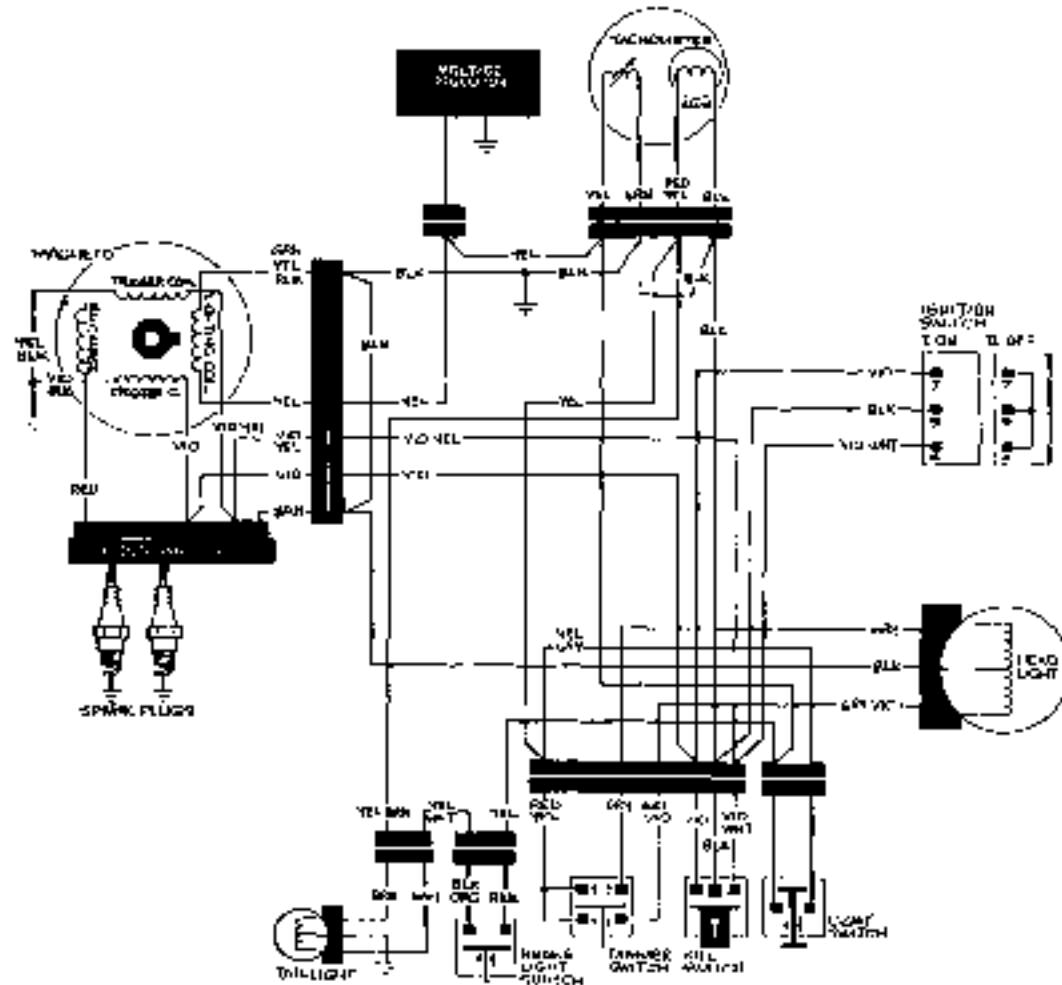

ELAN 250 (1976-1977)

After serial number 3013 03999

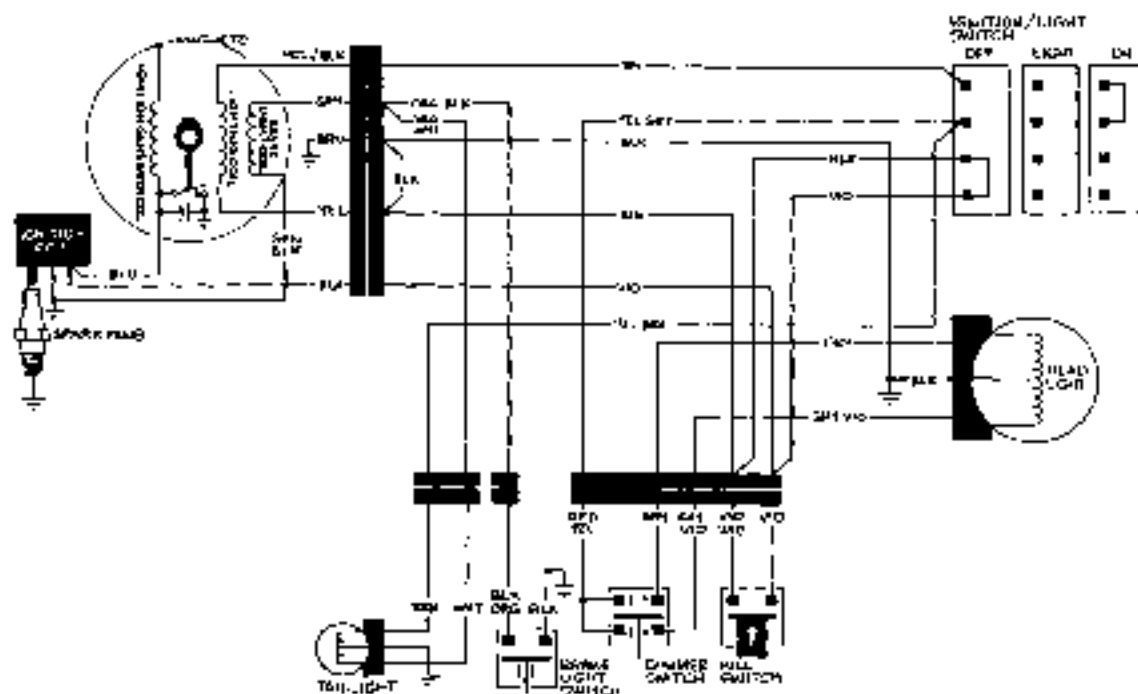
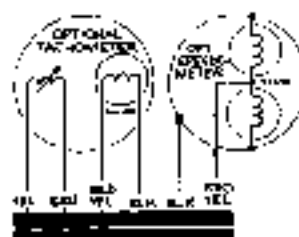

OLYMPIQUE 300 SINGLE (1976-1977)

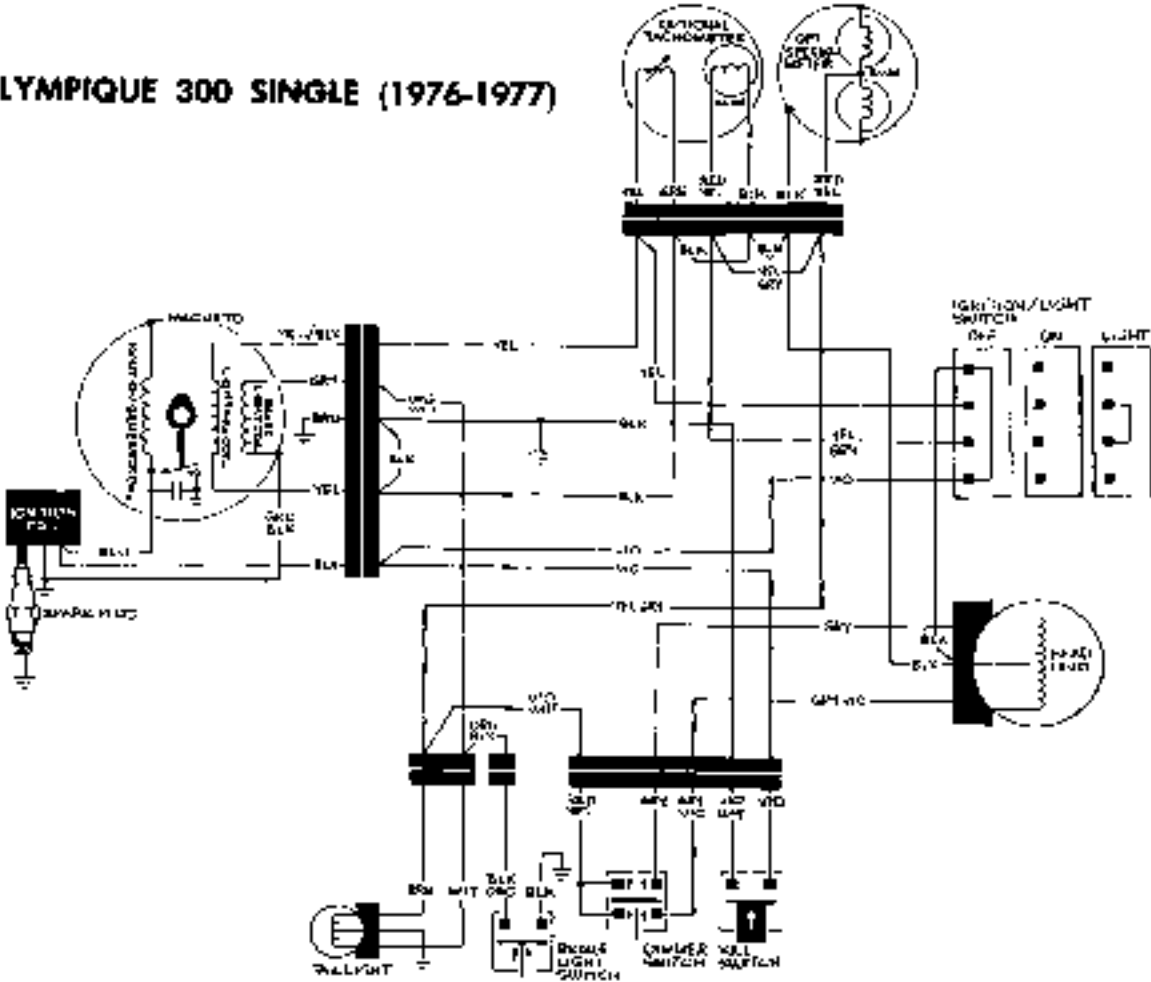

OLYMPIQUE PLUS 440 (1976)

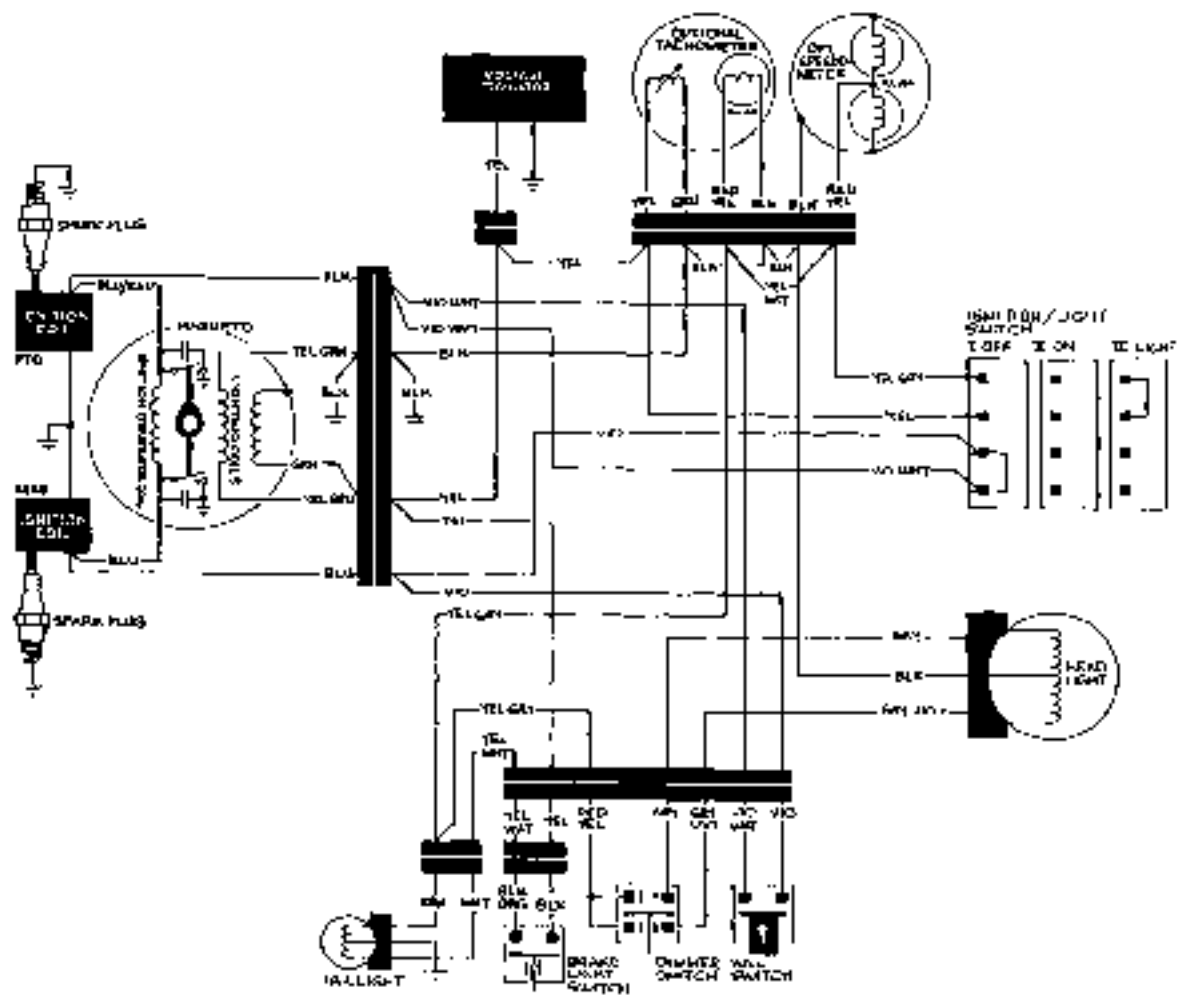

TNT R/V 250, 350 (1976-1977)

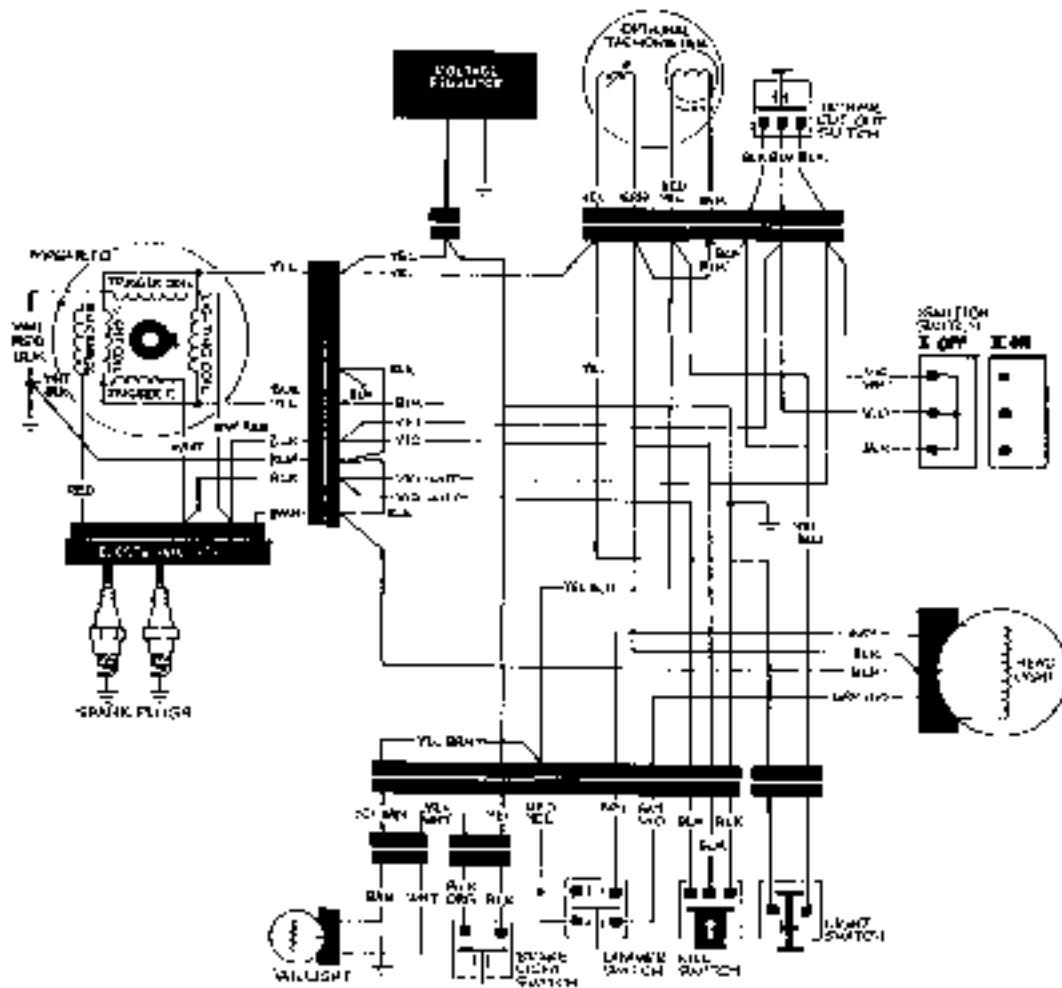

BLIZZARD 6500 (1976)

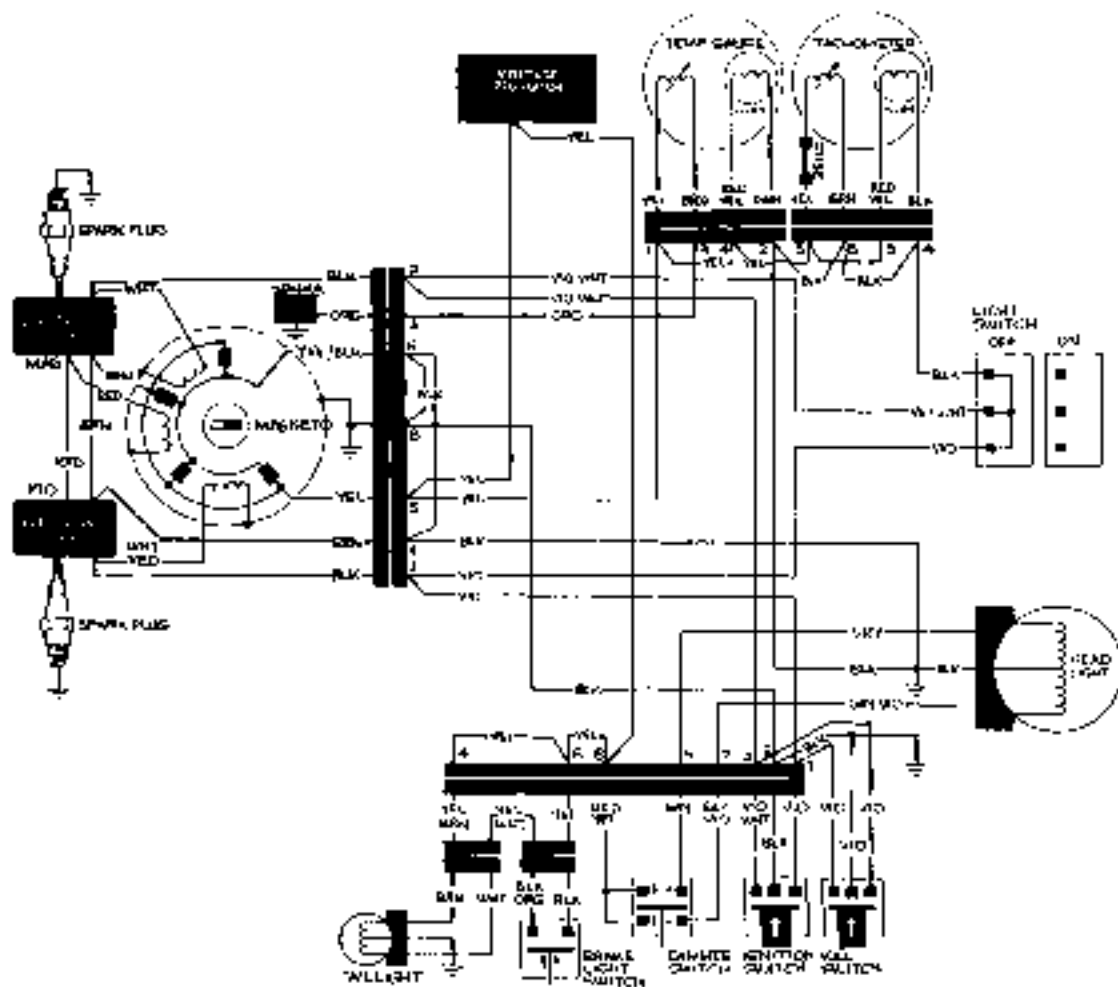

CITATION (1978-1979)

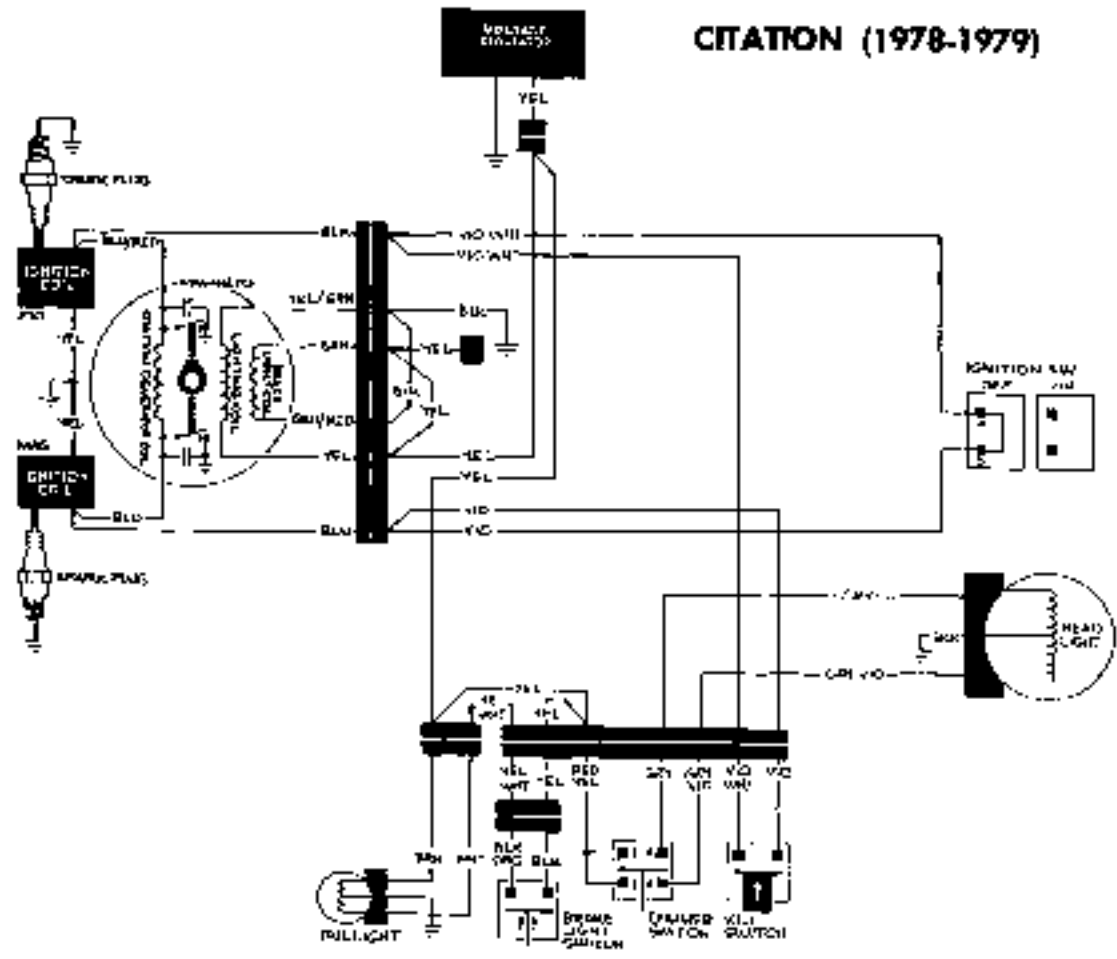

ELAN (1978-1979)

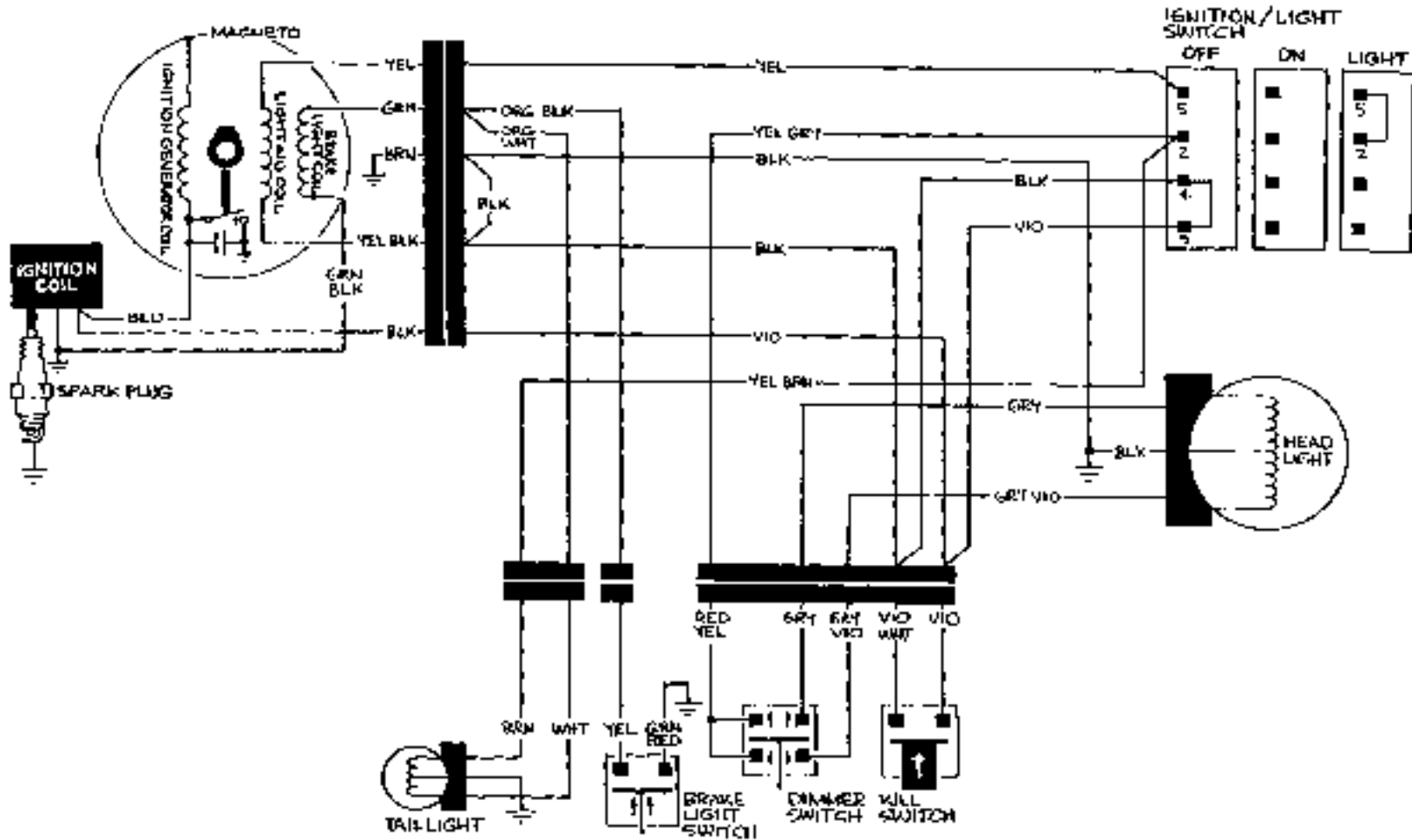

ELAN 250 DELUXE (1978-1979)

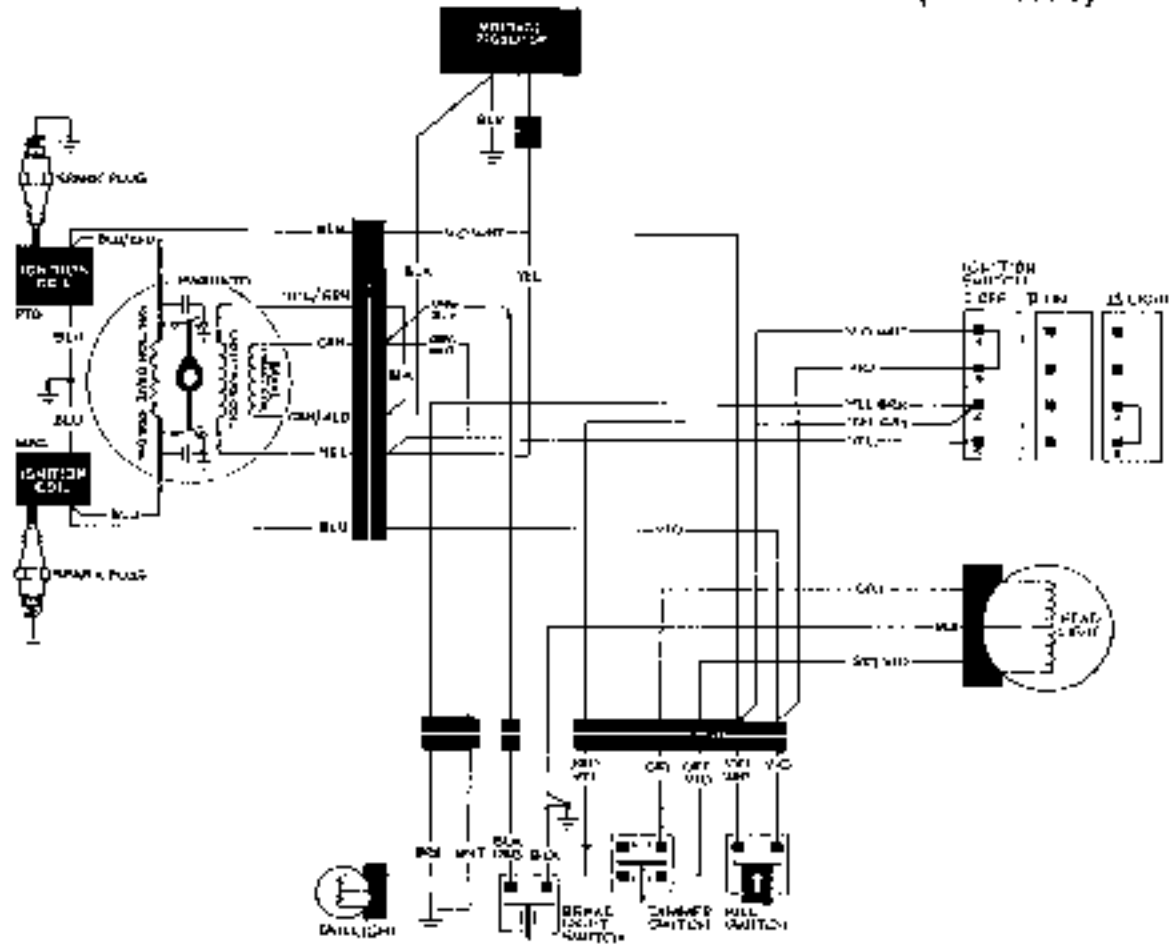

EVEREST 440E (1978-1979)

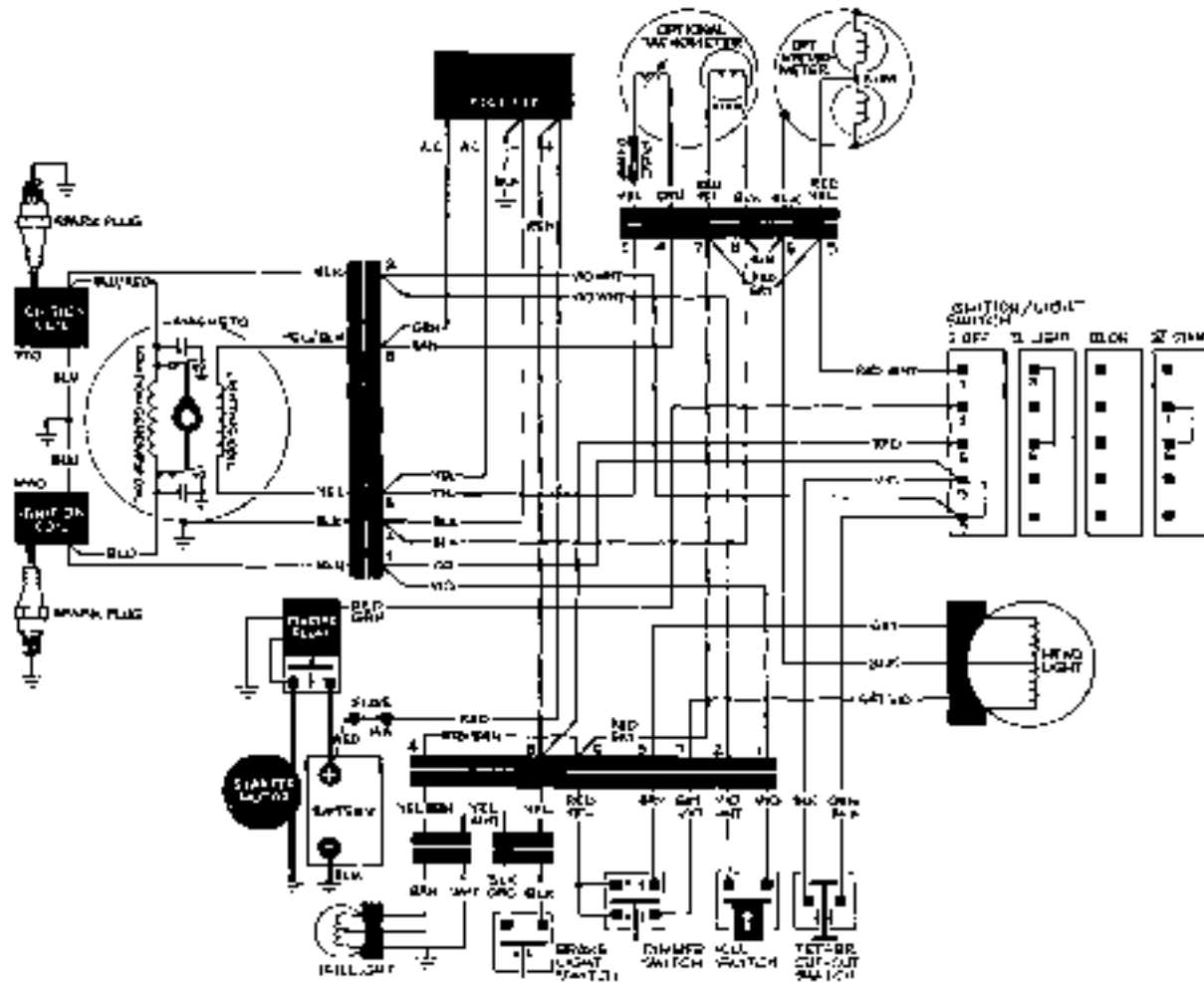

Copyright ©
1978 by
Everest
Motorcycle
Company

EVEREST 441LC (1978-1979)

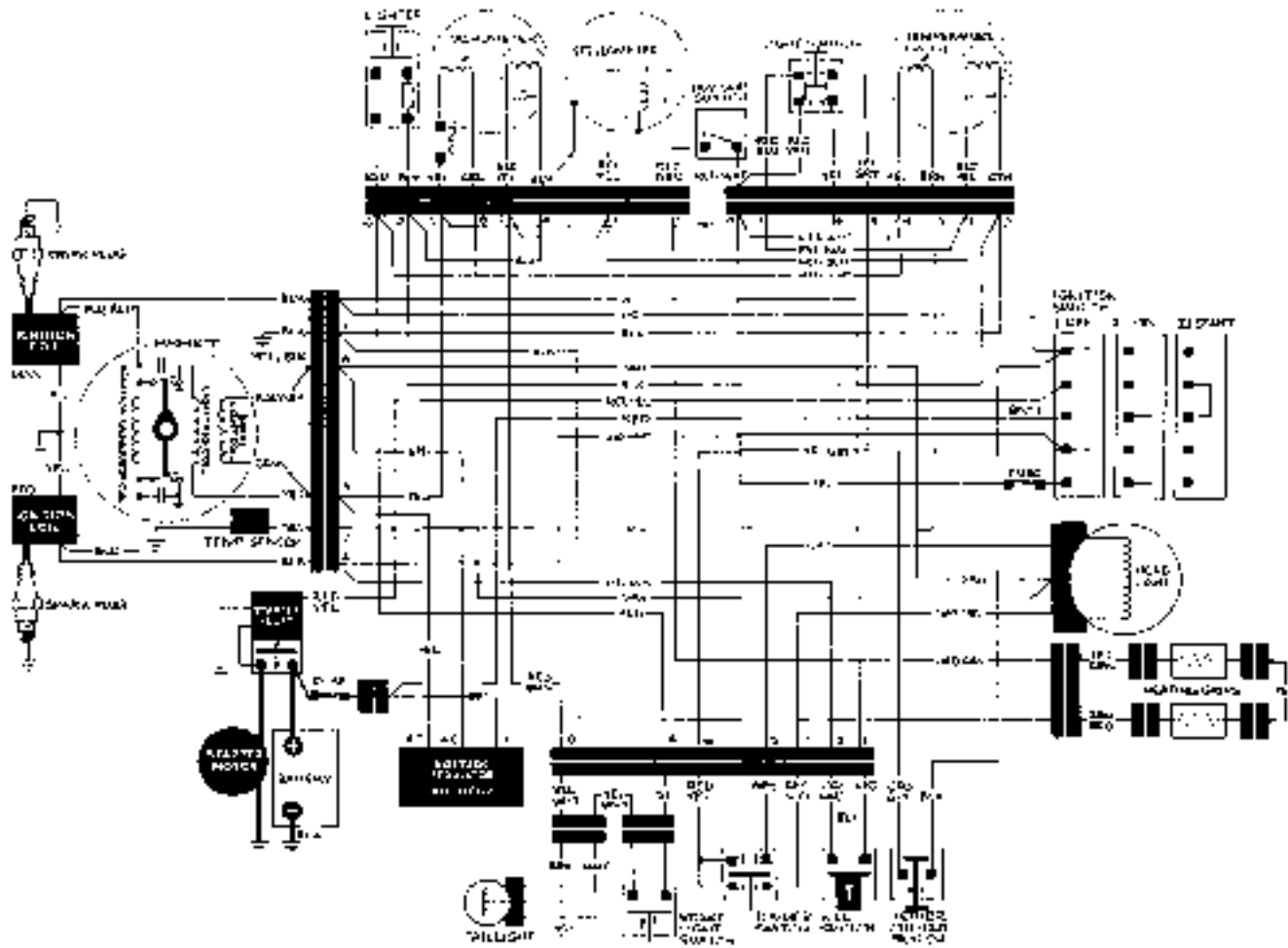

OLYMPIQUE 300-340 (1978-1979)

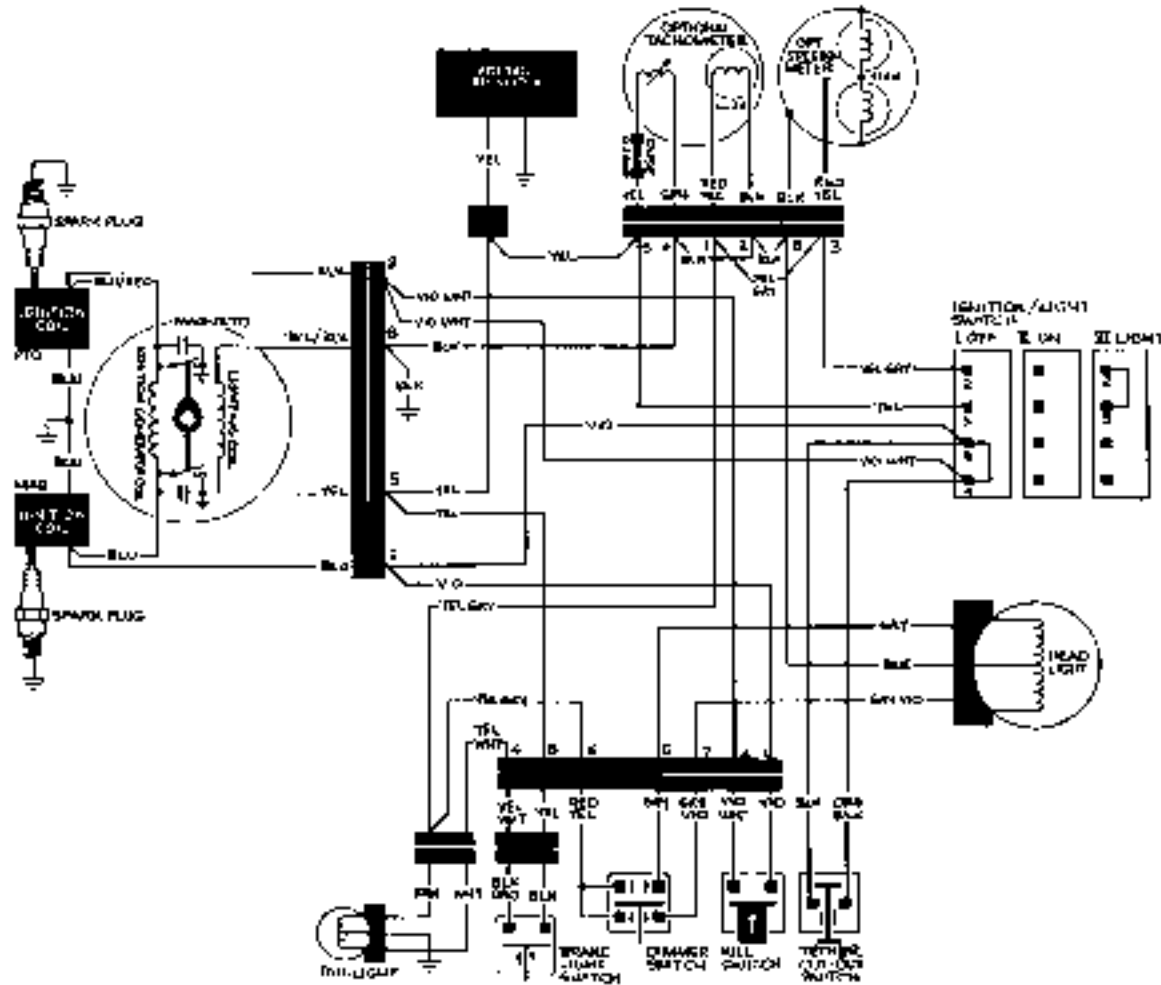

OLYMPIQUE 340E (1978-1979)

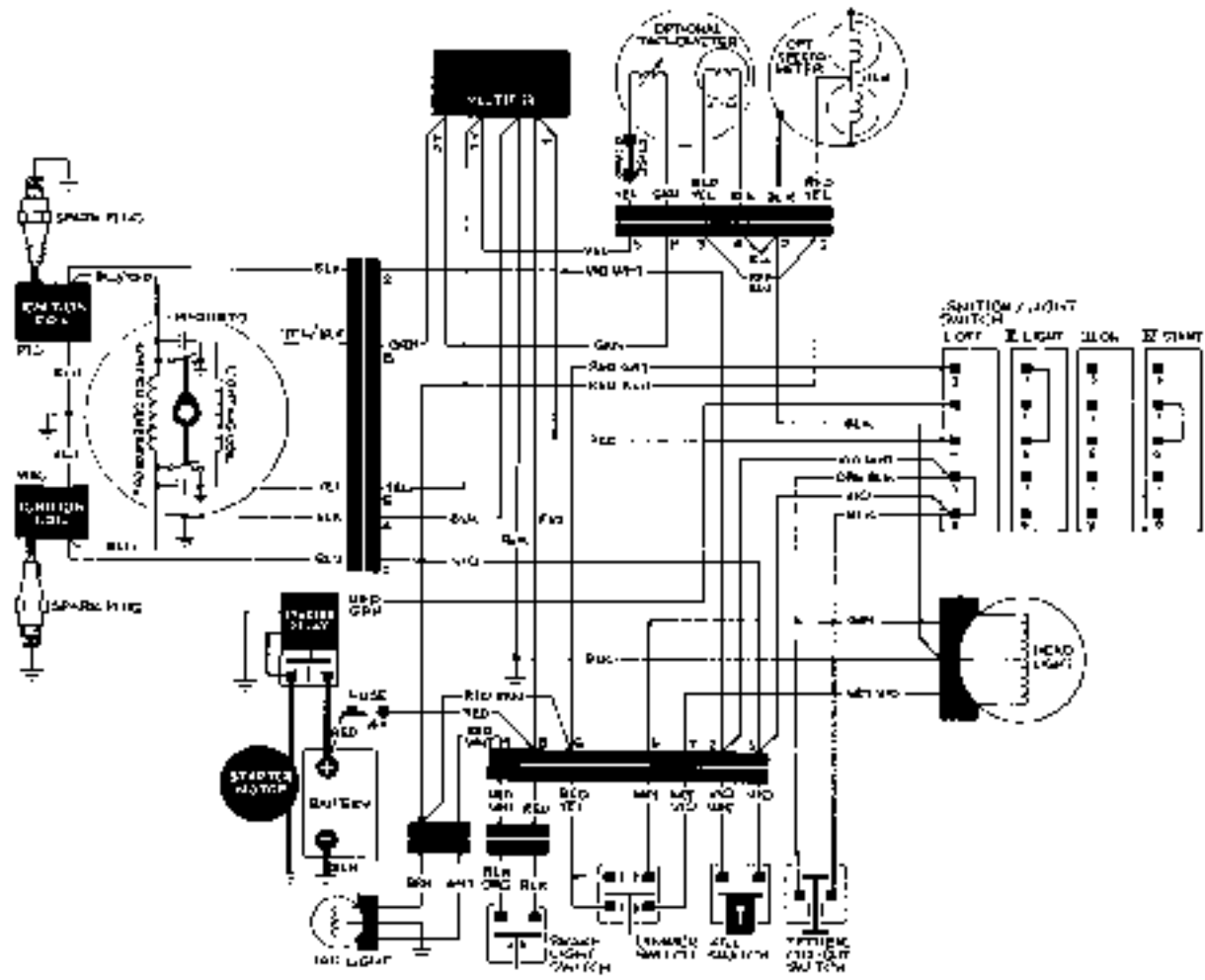

RV 340 (1978)

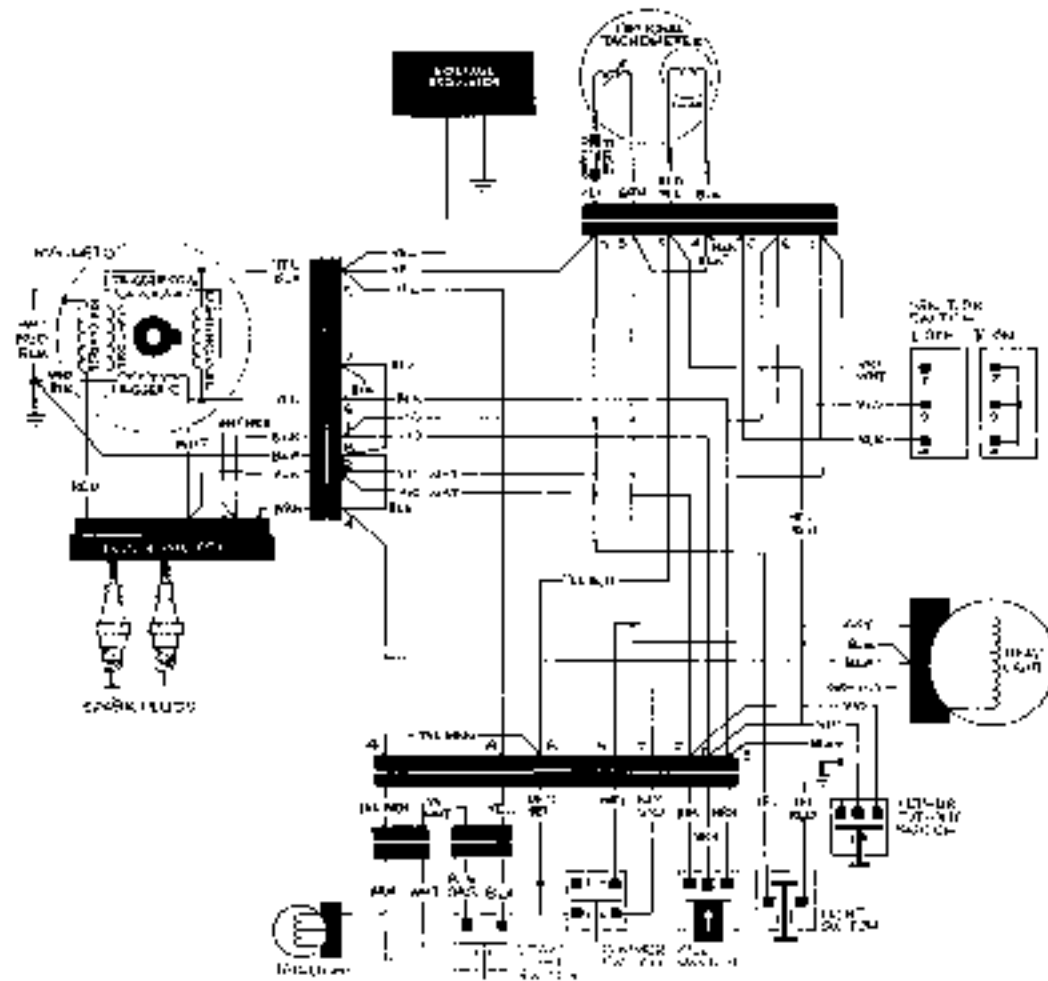

TNT F/A 340; TNT F/C 440 (1978)

EVEREST 340-440 (1978-1979)

