



em
electric motion



eTrek

Owner's manual



Summary

1. Manual introduction	5	3.7 Power supply	12
1.1 Important message from <i>Electric Motion</i>	5	3.8 Parts and consumables.....	12
1.2 About this manual	6	3.9 Operation under extreme conditions.....	12
2. Safety instructions	7	3.10 Reception of the motorcycle	12
2.1 Regulatory use	7	4. Vehicle identification	13
2.2 Operating information	7	4.1 Chassis number	13
2.3 Protective clothing	8	4.2 European certification label	13
2.4 Environment.....	8	4.3 Engine number (references).....	13
2.5 Location of important labels	9	4.4 Battery number (references).....	13
2.6 Fire hazard.....	9	4.5 Key number	14
2.7 Fall or accident	9	5. Overall view of the vehicle	14
3. Important observations and general information.....	10	5.1 Front view	14
3.1 Emission information	10	5.2 Rear view	15
3.2 Manufacturer's warranty and legal warranty	10	5.3 Right view	15
3.3 Vehicle range.....	10	5.4 Left view	16
3.4 Transport of the vehicle	11	6. Technical data	16
3.5 Spare parts and accessories	11	6.1 Engine.....	16
3.6 Lifetime optimization	11	6.2 Tires.....	16
		6.3 Fork	16

6.4 Shock absorber	16	9.1 Inspection before use	32
7. Controls and Components	17	9.2 Starting the motorcycle	32
7.1 Front/rear brake system and adjustment	17	9.3 Motor's behavior adjustment	33
7.2 Throttle grip	17	9.4 Braking	34
7.3 Lighting system.....	18	9.5 Stopping your motorcycle	35
7.4 Turn signals	19	9.6 Cleaning the motorcycle.....	35
7.5 Left-hand side handlebars switches	20	9.7 Motorcycle storage	36
7.6 Right-hand side handlebars switches	20	10. Setting the motorcycle controls	37
7.7 Driving Mode Selection Button	21	11. Front end maintenance	39
7.8 Side stand	21	11.1 Removing and installing the headlight	39
7.9 Locking and unlocking the steering lock.....	22	11.2 Bleeding air out of your forks	40
7.10 Dashboard overview	22	11.3 Cleaning the forks dust seals	40
7.11 Battery pack	23	11.4 Removing and installing the fork arms	41
7.12 Battery charger	25	11.5 Removing and installing the forks protections	44
8. Commissioning	26	11.6 Removing and installing the front fender.....	45
8.1 Preparation on receipt of the motorcycle in a shipping box .	26	11.7 Removing and installing the upper triple clamp.....	45
8.2 Instructions for initial commissioning	28	11.8 Steering Column Maintenance.....	47
8.3 Battery Charging Procedure	29	11.9 Removing and replacing the handlebars	48
9. Operating the motorcycle	32	12. Maintenance work on the central part	49

12.1 Raising the motorcycle on a stand	49	15.5 Checking spokes tension	76
12.2 Removing and installing the seat	49	16. Maintenance work on electrical components.....	77
12.3 Maintenance of the motorcycle frame	50	16.1 Removing and installing the battery pack	77
12.4 Removing and installing the motorcycle plastics	51	16.2 Replacing the front light bulb.....	82
13. Maintenance work on the rear of the bike	53	16.3 Replacing the tail light.....	84
13.1 Removing and installing the shock absorber.....	53	16.4 Replacing the front and rear turn signals.....	84
13.2 Swing Arm Maintenance	54	16.5 Replacing fuses.....	86
13.3 Removing and installing the rear fender assembly	54	16.6 Adjusting the speedometer.....	89
13.4 Transmission chain maintenance	56	17. Troubleshooting	90
14. Maintenance work on the brake system.....	60	17.1 Electric Motorcycle Precautions.....	90
14.1 Checking and replacing the brake discs.....	60	17.2 Caution regarding <i>Electric-motion</i> motorcycles	90
14.2 Checking and adjusting the brake fluid level.....	61	17.3 Fault diagnosis dashboard indicator.....	90
14.3 Checking and replacing brake pads.....	62	17.4 Tightening torque summary table.....	91
14.4 Adding brake fluid to the reservoirs.....	66	17.5 Maintenance schedule	92
15. Maintenance work on the wheels.....	68		
15.1 Removing and installing the front wheel	68		
15.2 Removing and installing the rear wheel.....	73		
15.3 Checking tire condition	75		
15.4 Checking tire air pressure.....	75		

1. Manual introduction

1.1 Important message from *Electric Motion*

Congratulation and thank you for purchasing *Electric Motion* ETrek electric motorcycle. We welcome you in our family devoted to electrons.

Electrical production on national grids becoming more and more clean and renewable, we are proud to provide you with an alternative to internal combustion engines and therefore allowing you to take part in solving the serious challenges we all face with air pollution and global warming.

The use of this electric motorcycle requires you to respect some recommendations and precautions in order to enjoy all the advantage that can offer this new clean alternative.

It is therefore imperative to read this manual which contains all the necessary information for preparing for the motorcycle first use, on how to operate it, on how to maintain the motorcycle and on what checks need to be carried. Furthermore, this manual contains all the information to prevent yourself and third parties from risks and accidents linked to the use of an electric motorcycle.

Because the *Electric Motion* team is continuously improving their products, it is possible that some information contained in this manual might change due to updates. If you have any doubt, do not

hesitate to check our website www.electric-motion.fr and download the latest version of the manual. Thus, no juridical claim can be carried out based on the information contained in this manual.

The content of this manual will allow you to maintain your bike in perfect working order in the most secure way possible.

1.2 About this manual

This manual only includes all the operating and maintenance information for the ETrek model of the *Electric Motion* brand. Under no circumstances should these instructions be used for the maintenance of other models of the brand.

Keep the user manual in an easily accessible location, so that it is close to hand when required.

The "right" and "left" designations refer respectively to the right or the left of the rider when he is in the driving position.

To illustrate all the maintenance operations, or to clearly designate elements of the motorcycle, pictures were used. Since *Electric Motion* is constantly improving their product, it is possible that certain parts of the motorcycle will change in geometry or in colors. However, this does not affect the operational processes explained in the manual.

The owner's manual is an important part of the vehicle. It must be transferred from owner to owner upon resale of the vehicle.



In this manual, the **CAUTION** designation will alert you to an object or situation that may cause injury to you or a third party or also damage your vehicle.

2. Safety instructions

2.1 Regulatory use

The *Electric Motion* ETrek has been designed and built to withstand mechanical stress resulting from road and off-road use.

The ETrek model has been assembled in order to be homologated and thus has all the equipment necessary to be ridden on roads opened to traffic. It is therefore forbidden to modify the accessories installed as standard on the motorcycle. *Electric Motion* can not be held liable for any modifications to the accessories installed on the motorcycle.



Use only *Electric Motion* parts. These parts have been tested and approved by *Electric Motion*. Under no circumstances should you try to replace the motorcycle components such as the battery pack or the engine with components of another brand, at the risk of causing irreversible damages to your vehicle.

Electric Motion does not assume any responsibility for the adaptation of unapproved parts.

2.2 Operating information

In order to guarantee a safe operation of the motorcycle, it is forbidden to carry out any modification on the vehicle.

For example, it is formally prohibited to use the vehicle if the vehicle, or one of its components, hasn't been properly maintained or if it is used outside the scope of the intended use. It is also forbidden to open the motor or the battery pack.



Any modification carried out on the vehicle by the customer does not render *Electric Motion* liable and voids any form of manufacturer's warranty.



Do not use the vehicle under the influence of alcohol, any medicine that could alter your capacity to drive or illegal drugs, or if you are not physically or mentally able to drive.



When using the vehicle, some components will start moving (chain, wheels) and will become dangerous for the user. It is important to take the right measures to avoid any unnecessary risks.

2.3 Protective clothing

To reduce the risks of potential injury while riding an ETrek motorcycle, on road or off road, it is necessary to be equipped with all compulsory protective clothing.

For any kind of trip and for any person that will ride the motorcycle, it is necessary to wear the correct protective clothing (helmet, boots, gloves, trousers and jacket equipped with protective means).



Failure to wear safety clothing or wearing damaged safety clothing is a serious safety hazard and can result in serious injury or death.

Like the driver, the passenger must also carry all the necessary protective clothing when riding the motorcycle behind the driver.



Only use protective clothing that is in perfect condition and complies with the legal requirements of the country of use.

2.4 Environment

In order to guarantee the durability of motorcycle driving, it is necessary to respect the rules of goodwill on the road with other users, motorized or not. Ensure that you remain within the legal framework of the use of a motorcycle. Be respectful to the environment and road users, and take into account the rights of other road users.

When the motorcycle parts are disposed of, be sure to comply with the recycling regulations of the country of use, in particular the battery pack.



Electrical components (motor, battery, etc.) and electrical appliances (battery charger) should not be treated as household waste and require strict recycling.

If you have any questions about the rules for recycling, contact *Electric Motion* Customer Service.

2.5 Location of important labels

Safety instructions are present in various places on the motorcycle. They allow the user to protect himself from certain risks associated with the maintenance of the motorcycle and to preserve the physical integrity of the motorcycle, its driver and its passenger.

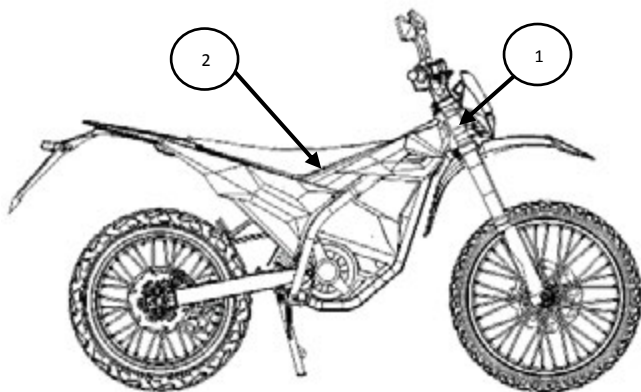

1	Manufacturer label
2	Warning label

 Never remove the warning labels. They allow the driver to avoid getting injured by exposing himself to a danger that can not be recognized without the presence of these stickers.

2.6 Fire hazard

As long as the battery pack remains in good working condition, there is no particular fire hazard on this vehicle. However, if the vehicle catches fire, it is necessary to inform the fire brigade that the fire originated from an electric vehicle with a lithium-polymer battery.

 When the battery pack is damaged, it may present a fire hazard. If the battery pack is damaged, contact *Electric Motion* customer service promptly.

2.7 Fall or accident

A fall or a road accident can damage the motorcycle significantly. After a fall or an accident, make a complete inspection of the vehicle to make sure that the users of the motorcycle do not expose themselves to any danger before riding again.

 A vehicle damaged for any reason may become a danger to users. In case of damage to the electrical components, please contact the *Electric Motion* customer service promptly.

3. Important observations and general information

3.1 Emission information

The development of the ETrek by *Electric Motion* has made it possible to obtain a zero emission motorcycle that does not emit any harmful particles for the environment. Therefore, it has no exhaust or evaporative emission.

This motorcycle does not use gasoline, engine oil or any other liquid fuel.

3.2 Manufacturer's warranty and legal warranty

All the work detailed in the maintenance guide must be carried out exclusively by a professional in order to retain the warranty right.

The warranty is cancelled in the event of damages resulting from manipulation or modification on the vehicle made by a person not certified by *Electric Motion*.

For additional information on the manufacturer's warranty and how to obtain it, contact *Electric Motion* customer service.

3.3 Vehicle range

The ETrek range is defined as the distance the vehicle travels on a single full charge of the battery.

It is then easy to understand that the range of the vehicle depends on how it is used. The more conservative you ride, the better range you can expect from your motorcycle.

There are many factors affecting the range, such as speed, acceleration, number of regenerative braking, weather conditions, tire pressure and payload.

For the first use of your ETrek, you are advised to remain cautious so you become fully aware of the range of your vehicle according to your driving style.

After you were able to make your own idea about the potential of the ETrek model, you can adapt your driving style to the range you would like to achieve.

 The range values in this manual are measured according to different standards, which may vary depending on the country of use.

In order to improve the range of your vehicle, all these characteristics must be taken into account:

Low range	Important range
Travelling at high speed	Low speed travel
Bad road condition	Good road condition
Important elevation	Low elevation
Aggressive driving	Smooth driving
Important payload	Low payload
Cold temperature	Hot temperature
Adverse weather conditions	Good weather conditions
Under inflated tires	Properly inflated tires
Poor general maintenance of the motorcycle	Good general maintenance of the motorcycle

3.4 Transport of the vehicle

The transport of the motorcycle can be carried out with the help of an approved trailer or a utility vehicle. It is important to ensure that the motorcycle is securely fastened before transporting it on the public road. The use of certified straps

to maintain the motorcycle is recommended to avoid any accidents related to the loss of the vehicle on public roads.

3.5 Spare parts and accessories

For safety reasons, we recommend that users of ETrek only use spare parts and accessories authorized and recommended by *Electric Motion* and have them fitted by a professional.

The company *Electric Motion* will decline any responsibility in case of equipment deterioration caused by products not approved by the brand.

For information on spare parts and their installation, contact the *Electric Motion* customer service or on our website www.electric-motion.fr.

3.6 Lifetime optimization

In order to optimize the life of the vehicle, it is important to perform the maintenance tasks listed in the user manual at the right mileage/time of use.

Maintaining maintenance intervals is important to keep a vehicle in good working condition and to avoid early wear.

What's more, incorrect adjustments of the chassis results in premature wear of the vehicle.

It is important to refer to the vehicle maintenance manual.

3.7 Power supply

The *Electric Motion* ETrek is powered by a lithium-polymer battery with a nominal voltage of 51.8V and a capacity of 52Ah. It is possible to remove and install the battery pack during certain maintenance operations. To carry out these operations, it is important to refer to the relevant chapter (↪ 16.1).

3.8 Parts and consumables

To maintain your vehicle, it is important to use parts and consumables (lubricants and maintenance products) in accordance with the specifications given in the user manual.

3.9 Operation under extreme conditions

The ETrek is not sensitive to water and rain. However, care must be taken to ensure that the water level on the road being ridden does not exceed the foot-rest height.



In the event the rider is stopped on a road with a high level of water, it is necessary to turn off the motorcycle to avoid a short circuit or a breakdown.

The ETrek can be used over a wide range of temperatures: -15°C to +55°C (5°F to 131°F).



The battery life of the Etrek model depends on the operating temperature:

Operating temperature (°C)	-15°C (5°F)	-10°C (14°F)	0°C (32°F)	25°C (77°F)	40°C (104°F)	55°C (131°F)
Decrease in battery range	-30%	-25%	-15%	-0%	-3%	-4%



Use of the vehicle in extreme conditions (sand, mud) leads to premature wear of the motorcycle's consumables (chain, brake pads, various bearings). It is then necessary to carry out the checks and the maintenance operations more often than prescribed in the manual of use.

3.10 Reception of the motorcycle

When receiving the ETrek model, it is necessary to perform some operations to make the motorcycle usable (assembly of parts protected during transport). Please refer to the corresponding chapter (↪ 8).

4. Vehicle identification

4.1 Chassis number

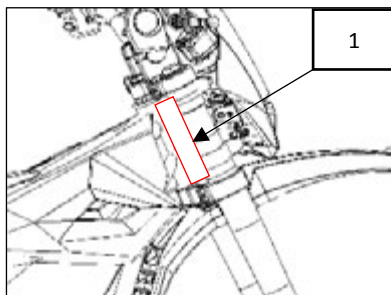

4.2 European certification label

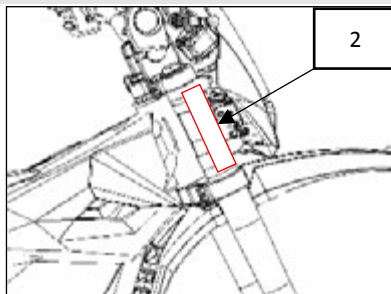

4.3 Engine number (references)

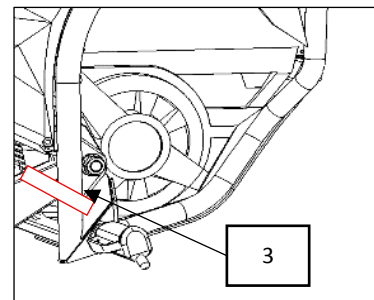

4.4 Battery number (references)

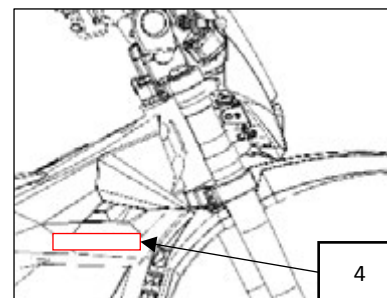

4.5 Key number

You have two keys associated with your motorcycle and only your own. An identification plate is attached to identify the key number that is linked to the motorcycle number. Please keep it in case of theft, loss or breakage in order to make a duplicate.

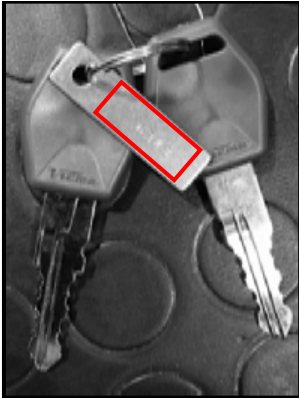

5. Overall view of the vehicle

5.1 Front view



5.2 Rear view



5.3 Right view



5.4 Left view



6. Technical data

6.1 Engine

Motor type	BLDC permanent magnet motor
Nominal power	6 kW
Peak power	11 kW
Maximal torque	27 N.m
Engine max speed	4500RPM
Cooling system	Air

6.2 Tires

Front tire	90-90 R21
Rear tire	110-80 R18

6.3 Fork

Fork Ø 33mm, Adjustable trigger and compression

6.4 Shock absorber

Damper R16V Adjustable preload

7. Controls and Components

7.1 Front/rear brake system and adjustment

The front brake lever is located on the handlebars right-hand side. A CBS-type system is used to distribute braking between the front and rear of the vehicle via the brake lever located on handlebars left-hand side.

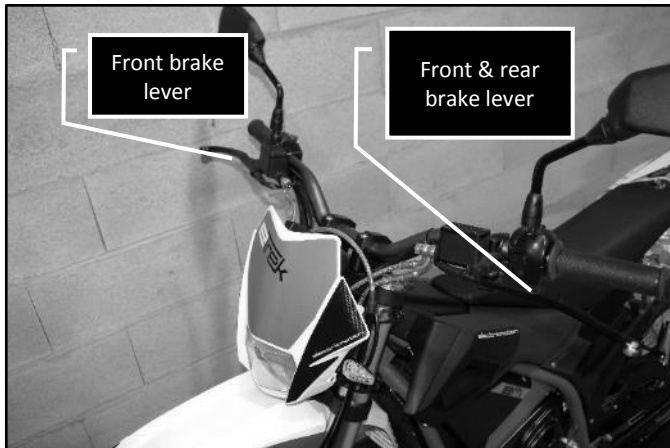



 The front brake lever acts only on the front brake. The rear brake lever acts on the rear brake AND the front brake. It is best to get use to this brake system at low-speed before riding normally.

 Before each use, check the condition of the brake system. A faulty brake system makes you vulnerable as well as the other road users.

7.2 Throttle grip

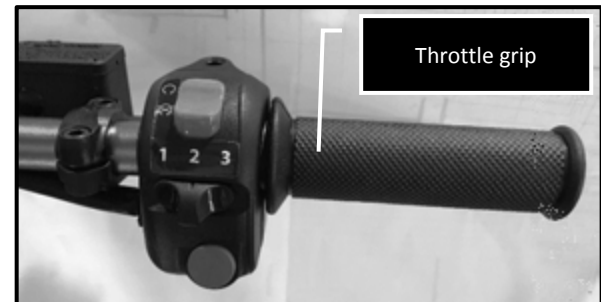
The throttle grip is located on the handlebars right-hand side.



 Before each use, check that the throttle grip rotates and returns correctly to prevent any accident.

7.3 Lighting system

The headlight is installed on the forks located on the vehicle front and the tail light is installed on the rear subframe of the vehicle.
Electric Motion advises to always have the lights turned on.

Headlight:



 The headlight can get hot when it is turned on.

Tail light:



 Make sure that the lighting system is always in working order. Riding without a lighting system does not allow other users to see you and does not allow you to see other users. It is mandatory to have a lighting system in good working order.

7.4 Turn signals

Front turn signals:

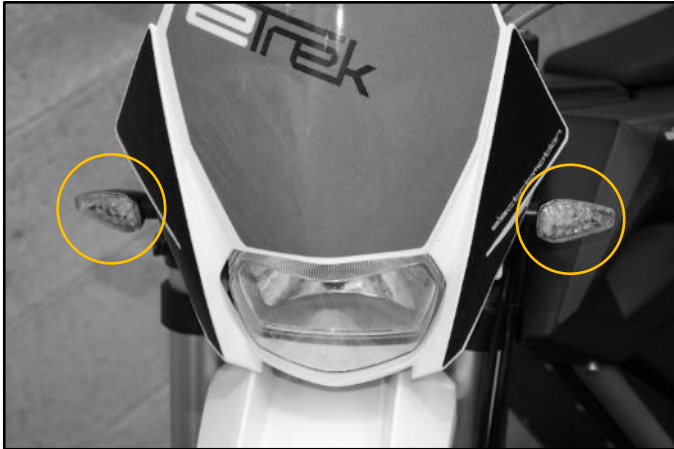

Rear turn signals:

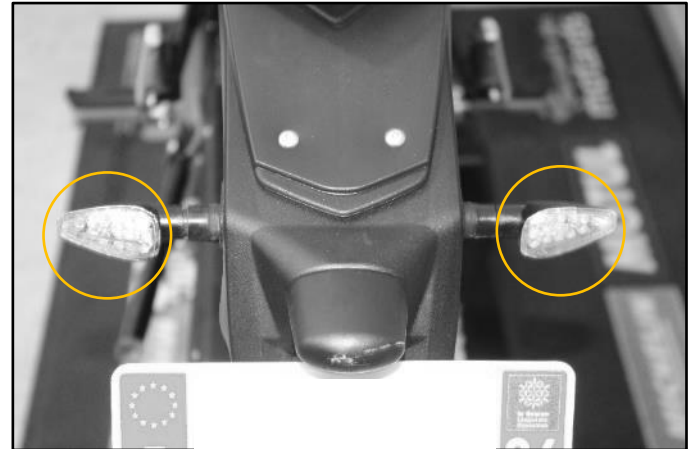

7.5 Left-hand side handlebars switches

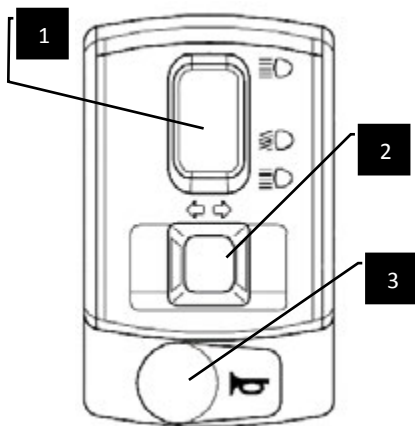

1	Headlight high / low beam switch
2	Turn signal switch
3	Horn button

7.6 Right-hand side handlebars switches

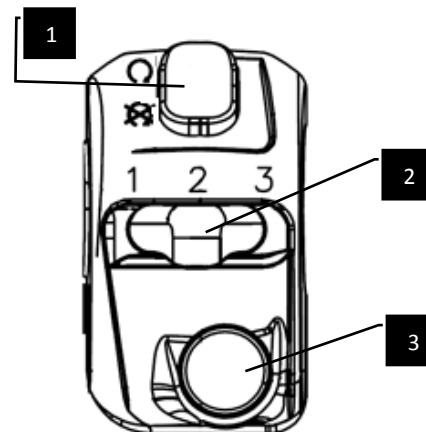

1	Emergency stop switch
2	Driving mode selection button
3	Regenerative braking button

7.7 Driving Mode Selection Button

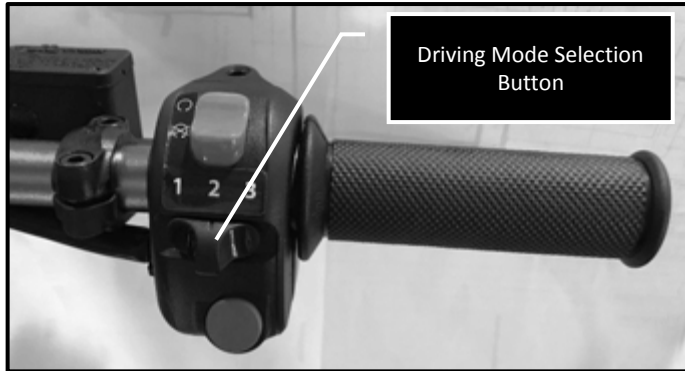

The driving mode selected by the user is displayed on the dashboard (👉 7.10).

7.8 Side stand

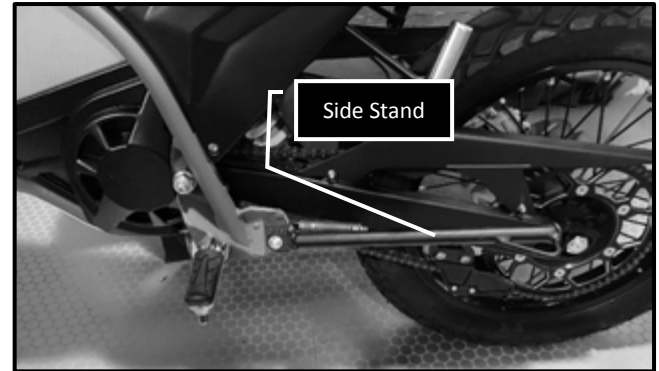

7.9 Locking and unlocking the steering lock



The steering lock can be locked when the handlebars are turned all the way to the left or to the right. Simply press the key and then turn the key as shown in the picture below to lock (counter-clockwise) and to unlock (clockwise).

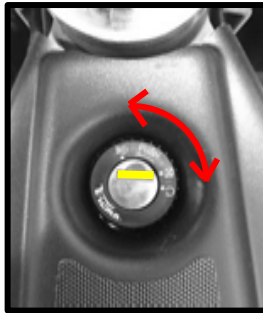

7.10 Dashboard overview

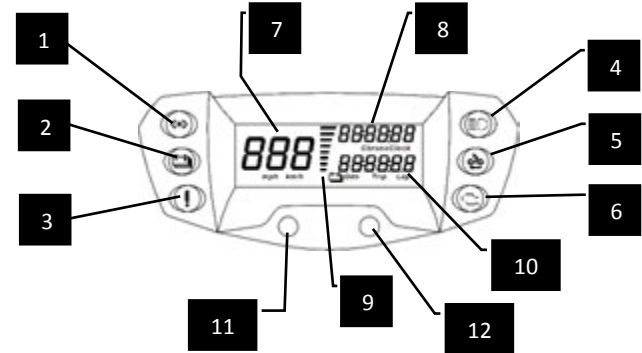

1	Right and left turn signals indicator
2	Low battery Indicator
3	High temperature indicator
4	Headlight high beam Indicator
5	"Ready to ride" Indicator
6	System warning indicator
7	Speedometer (km/h or mph)
8	Display of the driving mode selected
9	Battery charge indicator
10	Total motorcycle mileage or trip odometer
11	Select button
12	Adjust button

7.11 Battery pack

The battery of the ETrek is inside the battery pack. The casing of the battery pack makes it possible to protect all the cells composing the battery against the aggressions of the external environment. Up to a certain limit, the battery pack is protected against splashes of water, dust and other harmful elements for the battery (rain, driving in dry weather). However, the user must be careful not to use the ETrek motorcycle under extreme conditions, otherwise the vehicle may be damaged irreversibly (full immersion of the motorcycle).

The battery pack uses a set of lithium-polymer cells assembled in series. These elements have been tested to obtain the best performance while maintaining maximum reliability.

It is important to note that the maximum capacity of the battery will be obtained after **about 10 cycles of full charge / discharge of the vehicle.**



The battery pack is dimensioned to achieve the best possible reliability / performance ratio. It is possible, however, that certain maintenance operations will be carried during the lifetime of the vehicle.

All work on the electric components of the motorcycle, and especially on the battery pack, is accompanied with risks of causing electric arcs if precautions are not taken. Working on the electric components of the motorcycle requires special training, qualifications and tools.

Therefore, all work that is not explicitly described in this manual, and which concerns an electronic device, must be carried out only by an *Electric Motion* qualified electrician.

Do not open the motor or the vehicle battery pack. If there are any problems with these items, contact *Electric Motion* Customer Service.



When receiving the motorcycle, it is important to charge the battery pack according to the recommended battery charging procedure.



Be sure to turn off the motorcycle after each use or whenever the motorcycle is not used for a long period of time. Make sure that all the lights are turned off when the ignition key is switched off.

Battery management system (BMS)

The BMS (battery management system) is an internal component of the battery pack. It allows the management and the control of all the battery cells during charging and discharging of the vehicle.

The BMS therefore protects the battery with the help of an electric safety relay.

The main roles of the BMS are therefore:

- Prevent the charge of the battery when the outside temperature is below 10°C (50°F).
- Prevent the charge of the battery when the outside temperature is above 45°C (113°F).
- Prevent the discharge of the battery when the outside temperature is below -15°C (5°F).
- Prevent the discharge of the battery when the outside temperature is above 55°C (131°F).
- Allow a uniformly distributed charge of all cells in the battery pack.
- Optimize charging and discharging of the battery.



The BMS is a vital component of the motorcycle for its good working order. Do not try to modify it by any means.

Battery charge level

The battery pack is connected to the dashboard and therefore allows the display of the state of charge directly on the dashboard.

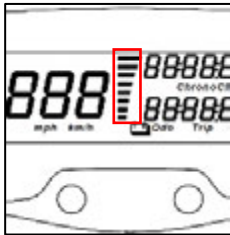

The battery charge indicator is composed of 8 bars indicating the range of the motorcycle.

As you approach the last bar, the low battery indicator LED lights up indicating that you reached a low battery charge level:

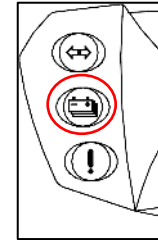

When this indicator light turns on, the battery is in low voltage, which means that the motorcycle can cut off in order to prevent any damages to the cells. **It is important to avoid excessive speeds and abrupt accelerations when the low battery indicator lights up and to reach a charging station as fast as possible.**





If you plan on using any highway and depending on the battery charge left and the distance left to travel, check first that there is a charging station on your way or that there is a highway exit so you don't get stranded.

7.12 Battery charger

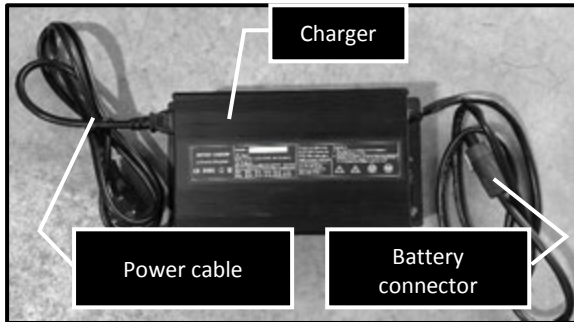
The ETrek model can be delivered with 3 different types of battery chargers with different charge speeds: a 10A charger, a 15A charger and a 25A charger.



 In a wet environment, there is a risk of creating electric arcs when charging the vehicle. The battery charger is not humidity-proof. It is important to use the battery charger in a dry environment and to ensure that no liquid are spilled on the charger.

 In case of incorrect handling of the battery charger, the safety of the user is not guaranteed.

 Use the battery charger only with an *Electric Motion* battery pack.
Use the battery charger only by connecting it to a safe electric socket in accordance with the regulations in force in the country of use. Do not use an adapter or extension cord other than the one already presents on the charger.

 Do not modify the battery components by any means. Check that the charger's power cable and battery cable are in good condition before each use.

8. Commissioning

8.1 Preparation on receipt of the motorcycle in a shipping box

On receipt of the vehicle, the handlebars are disassembled, the footpegs are folded and the brake system is attached to the transport plate.

It is therefore necessary to assemble all these components in order to use the motorcycle.

Assembling the handlebars upon receipt

The handlebars are supplied in the box accompanying the motorcycle and must be assembled in accordance with the following procedure:



Do not remove the plastic wedges on the brake levers before the assembly is completed.

- Remove the brake master cylinders from the transport plate / remove the transport plate from the bar mounts.

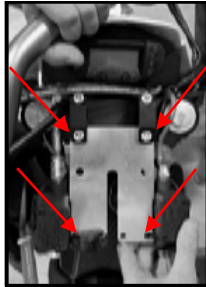

The brake master cylinders must be handled with care, do not turn them upside down so that no brake fluid is lost.

- Reassemble the handlebars as shown in the following picture with the 4 screws provided, tightening them at 20 Nm, take care to center the handlebars and screw the bar mounts evenly.

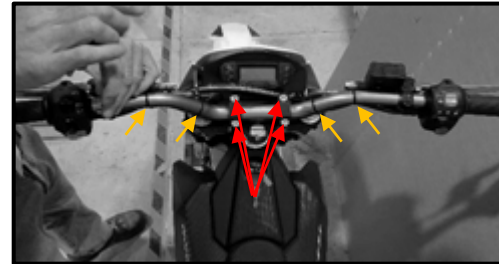

- The handlebars angle must be set in accordance with the user's preferences.
- Attach the wires on the handlebars as shown in the above picture with the cable ties provided.

Installation of the brake system upon receipt

The brake system is fixed on a transport plate to prevent damage during transport. Before using the vehicle, it is important to make sure that the brake system is correctly positioned. It must be assembled in accordance with the following procedure:

- Reassemble the master brake cylinders with the supplied screws, tightening with a torque of 10 Nm.



The brakes are mounted on a plate to prevent them from being tilted during transport. Tilting the master brake cylinder for a period of time may cause a decrease in braking.

Assembling the mirrors

- Mount the mirrors in the threaded holes located on the brakes master cylinders.



- Tighten the mirror using a 17-spanner and a 14-spanner after positioning the mirrors as desired.

8.2 Instructions for initial commissioning

Before using the motorcycle, the user must carefully read the entire user manual.

Because driving an electric motorcycle is a new driving experience, a period of adaptation is necessary to become familiar with the new sensations that it brings before being fully confident when traveling on roads open to others traffic users.

Before using the motorcycle on the road, ride it in a secure area to get acquainted with riding an electric motorcycle. Try all settings on the vehicle and get familiar with the results.

To maintain control of your vehicle, always hold the handlebars with both hands and keep your feet on the footpegs.



Do not use the vehicle if you are not in full possession of your means.

Adapt a cautious behavior for you and other road users.

Do not exceed the vehicle's permissible payload.

Do not leave your vehicle unattended (risk of theft).



An electric motorcycle makes no noise when it is turned on, do not let yourself be caught by surprise.



When the battery level is low, the motorcycle keeps working on an energy saving mode. The vehicle power is reduced but it is in no

way a breakdown. After charging the battery, full power will be available again.



When the battery has been over discharged, the motorcycle will not start charging straight away. It is necessary to wait until the vehicle automatically start charging again.

8.3 Battery Charging Procedure

The procedure for charging the vehicle being meticulous, it is important to be familiar with this procedure before the first charge of the battery.

The battery must be charged over a temperature range from 10°C to 40°C.



Due to the strong current involved, electrical arcs may occur when connecting the connector to the battery.

Use only the charger supplied with the motorcycle to charge the battery. This charger is designed to operate only with a lithium polymer battery.

Always place the charger on a flat, solid surface in a dry, ventilated area.

Never cover the charger while charging the battery, otherwise it may interfere with its ventilation and cause the charger to overheat.

Charging Procedure for 10A, 15A and 25A chargers

- Turn off the vehicle (👉 9.5).
- Remove the seat saddle from the vehicle (👉 12.2).
- Plug the battery charger into a power outlet.



- Only for the 10A and 25A chargers: Turn on the switch located on the back of the charger.
- Check that the charger LED lights are on and as shown on the picture:



- Connect the charger to the battery.

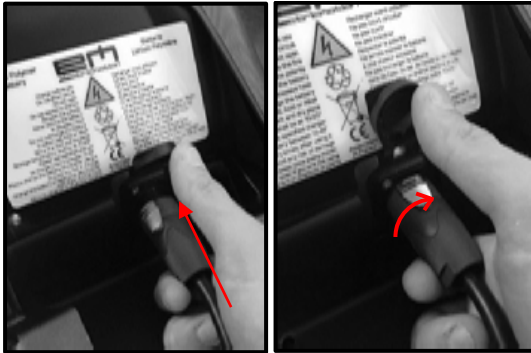

 When the connector is inserted in the battery, a “click” can be heard indicating that the battery has switched to a charging mode. The battery will then start charging automatically. When switching to charging mode, both charger’s LEDs will be red.



- When the charging process is finished, LED 2 then returns to green.



- Disconnect the charger from the battery pack.

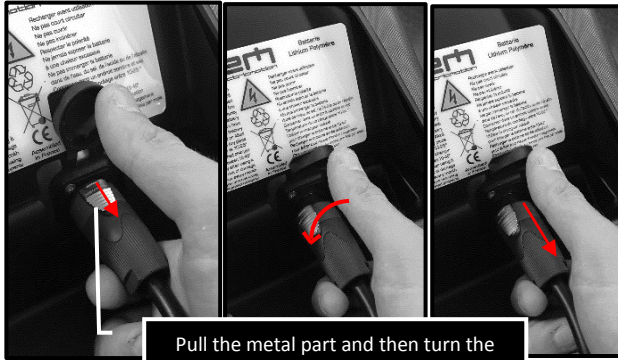



Pull the metal part and then turn the connector

- Only on the 10A and 25A chargers: Turn off the switch located on the back of the charger.
- Switch off the charger by disconnecting it from the power outlet.



Note: If there is a problem during charging, please repeat the charging process **from the beginning** in order to enable the battery to recharge again.

 When the motorcycle is charging, do not turn on the motorcycle using the ignition key, it would immediately stop the charging process.

 Regardless of the charger used, do not leave the battery charging for too long, otherwise damage may occur. If the battery has a failure, the charger's LED n°2 will not be red but green indicating that the battery is not charging. This may be due to a damaged battery. It is therefore essential to contact a professional certified by *Electric Motion*.

 Take care not to put any metal object in the under-seat storage, to avoid any short circuit with the charging connector.

 Take care not to put any objects fragile and sensitive to heat in the under-seat storage.

9. Operating the motorcycle

9.1 Inspection before use

It is important that the user of the ETrek motorcycle checks that the condition of the vehicle is intact and that it can be safely used before each journey.

In order to be used, the motorcycle must be in perfect technical condition.

The pre-ride inspection consists of:

- Check the state of charge of the battery.
- Check that all the screws and bolts are tight.
- Check for correct function of all the electrical equipment.
- Check that the brake system is in proper condition (brake fluid, brake pad wear and system operation).
- Check the condition and pressure of the tires.
- Check the condition of the final drive system (chain and sprocket, lubrication).
- Check for correct function of all the control devices.



If there are any abnormalities on the motorcycle during the pre-trip inspection, do not take any risk, contact *Electric Motion* customer service.

9.2 Starting the motorcycle

To start the motorcycle safely, follow these instructions:

- Fold / raise the kickstand.
- Turn the key switch to the ON position.

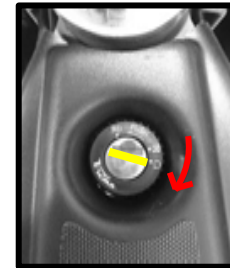

- The battery then turns on.
- Wait a few seconds for the motorcycle's initialization.
- Press the motor stop switch to the ON position.





- The power-on indicator is displayed, the motorcycle is ready to be used.



- Twist the throttle grip toward you (counter-clockwise) to increase the vehicle speed.
When the throttle is twisted away from you (clockwise), the speed decreases.

 The motorcycle should be at a complete stop before turning it on.

 When the bike is in working order, it does not make any noise!

 Under no circumstances should the kickstand be unfolded when the motorcycle is used.

9.3 Motor's behavior adjustment

The ETrek motorcycle has 3 driving maps. The driving maps are selectable via the right hand switchgear.

These maps affect the motor's behavior, it may therefore be more or less lively. The motorcycle range will vary between each map.

Mode 1 corresponds to city use, progressive acceleration and maximum speed of ~ 70km/h *(+/- 5km/h).

Mode 2 "Std" corresponds to normal use, under all conditions, maximum flat speed of ~ 85 km/h * (+/- 5 km/h).

Mode 3 "Sport" is to be used only for **short periods**, it allows the motor to deliver all its power. But **using it for too long can cause the motorcycle to overheat**, which will then automatically lower its power in order to regulate its temperature.

* Speed readings according to driving profile and typical user.

 Driving too fast or aggressive can cause overheating problems.

 Make sure you are aware of the motorcycle different behaviours when changing maps before using them in traffic/open roads. These changes in behaviour could surprise an uninformed driver.

9.4 Braking

The front brake lever, located on the right hand side of the handlebars, brakes only the front wheel. The rear brake lever on the left hand side of the handlebars allows the rear brake to be activated but it will also slightly activate the front brake. The distribution of the braking proportions is managed by the CBS system.

The brake levers control the brakes when the lever is squeezed. It is important to be fully aware of the motorcycle's braking capacities for safe driving on public roads.

To brake properly, under normal traffic conditions, first close the throttle. Then brake using simultaneously the front and rear brake levers for strong braking. For soft braking, only use the left lever (front and rear brakes).

For low-intensity braking, the use of the regenerative brake is recommended, which allows the battery to be recharged at the same time.



 When braking, the throttle grip must be in the closed position (acceleration stopped).

 Braking too strongly causes the wheels to lock and makes the motorcycle dangerously uncontrollable. It is necessary to adapt your braking to the situation and to the pavement condition.

 Check the condition of the brake system before each use. A wet or dirty brake system greatly reduces braking performance. Clean and degrease the system if grease or dirt is present.

If there is any doubt about the condition of the brake system, contact *Electric Motion* customer service.

9.5 Stopping your motorcycle

To turn off the vehicle, follow the procedure below:

- Press the motor stop switch to the OFF position.



- Turn the key switch to the OFF position.

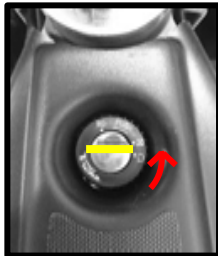

- Unfold the kickstand so it is down and lean the motorcycle on it. Make sure that the motorcycle is stable and on a hard and stable ground to avoid falling. Beware of where you park your motorcycle and if there is a slope or not, the motorcycle having no gear to stop it moving.

 Do not leave your motorcycle unattended after use.

After riding, some parts of the motorcycle may be hot, so be sure not to touch them before they are fully cooled to avoid any risk of burns.

9.6 Cleaning the motorcycle

The motorcycle must be cleaned with clear water. It is possible to use soap to clean it.

To clean your motorcycle it is necessary to:

- Wash the motorcycle without insisting on the components vulnerable to moisture (electrical components, external controls and external bearings).
- Rinse the motorcycle thoroughly with clean water.
- Dry the motorcycle, insisting on the electrical contacts.



Do not clean the handlebars directly with a high pressure washer.

9.7 Motorcycle storage

In case of long-term storage of the vehicle, it is important to apply additional measures.

It is necessary to:

- Clean the motorcycle correctly (👉 9.6).
- Raise the motorcycle using a bike stool or dirt bike lift stand (allowing the suspensions of the vehicle to be relieved) (👉 12.1).
- Park your vehicle in a dry place, where the temperature is between 10°C and 25°C, which is not subjected to excessive temperature variation and protected from UV radiation.
- Cover the motorcycle with a breathable cover.

When storing your motorcycle, it is important to follow a strict procedure to protect the battery during storage.

When storing the motorcycle for longer than one month

Store the battery with a charge level indicator as shown in the picture below.

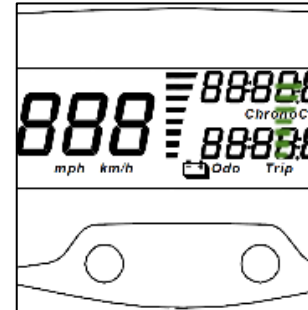

Place the battery pack in an environment not exposed to direct sunlight and at temperatures below 25 ° C. Recharge the battery every month if not in use.

Note: There is no special precaution to be taken to restart the motorcycle.



The battery charge level should be checked monthly, recharge the battery if necessary with the supplied charger.



If the motorcycle does not start after the storage period, do not attempt to recharge the battery and contact *Electric Motion* Customer Service immediately.

10. Setting the motorcycle controls

It is important to find your place on the motorcycle before starting to drive. Being at ease on your vehicle makes it possible to travel safely on public roads and to have a fluid riding style.

To adjust your ETrek motorcycle at your convenience, adjust the position of the motorcycle levers, mirrors and handlebar position according to the following procedures:

Levers position adjustments

The levers can be adjusted using a 5mm Allen key. Tightening torque of 8Nm.

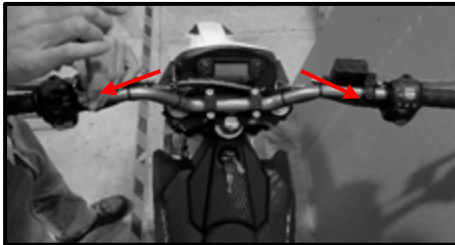

Please, frequently check that the master cylinders screws and bolts are tight.

Mirrors position adjustments

The mirrors can be adjusted using two spanners, one of 17mm and the other of 14mm. Untighten / tighten the mirrors with of the 17mm spanner while holding the 14mm spanner.





Handlebars position adjustments

The handlebars can be adjusted by untightening the 4 screws holding the handlebars on the bar mounts.

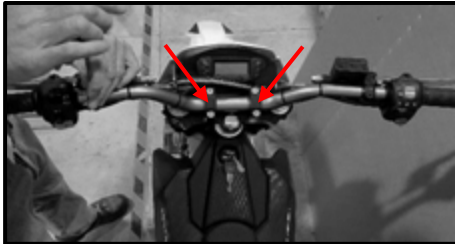
- Loosen the 4 screws with a 6mm Allen key.
- Adjust the handlebars to your preferences.
- Tighten the 4 screws evenly (tightening torque of 20Nm).



 Please, frequently check that the screws holding the handlebars on the bar mounts are tight.

 Please, make sure that the handlebars are centered on the bar mounts.

11. Front end maintenance

11.1 Removing and installing the headlight

Removing the headlight

- Stop the vehicle (🔧 9.5).
- Remove the headlight rubber brackets around the fork.

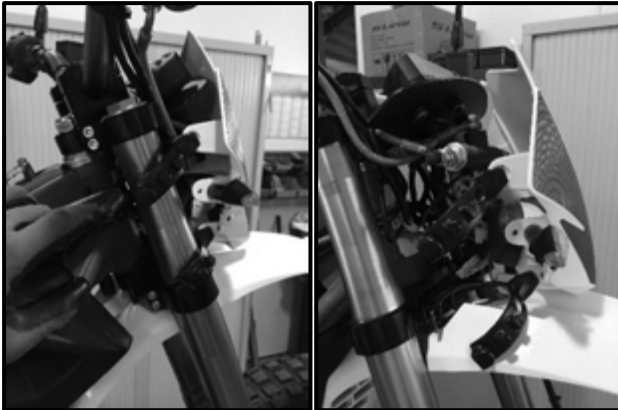

- Gently disconnect all electrical connectors. It is advised to label the connectors in order to know which connectors go together for reassembly. You can use electrical tape from different colors as shown in the picture below.



Installing the headlight

- Reconnect the electrical connectors together taking care not to damage them and checking their cleanliness.
- Position the headlight back in place by clamping the rubber brackets around the fork.

11.2 Bleeding air out of your forks

- Stop the vehicle (👉 9.5).
- Raise the motorcycle front wheel off the ground using a dirt bike lift stand (👉 12.1).
- Unscrew the fork's bleeder screw with a flat screwdriver.



- Wait a few seconds until all the air has escaped.
- Tighten the fork's bleeder screw.

11.3 Cleaning the forks dust seals

- Stop the vehicle (👉 9.5).
- Raise the motorcycle using a bike stool or a dirt bike lift stand (👉 12.1).
- Remove the forks guards (👉 11.5).
- Slide down the dust seals using a flathead screwdriver.

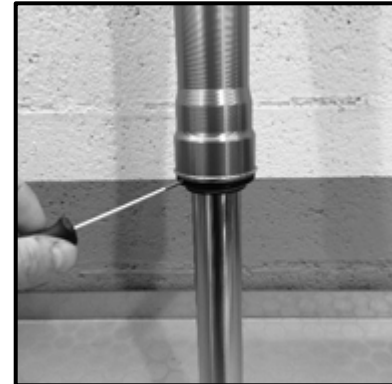

- Correctly clean the dust seals and their housing inside the forks.



- Lubricate the dust seals and their housing inside the forks. Remove any excessive lubricant.
- Slide the dust seals back to their original position and push them firmly in their housing using your fingers.



It is important to frequently clean the forks dust seals. They allow the forks seals to work in a clean environment. If a lot of dust or mud is allowed between the forks seals and the dust seals, the forks seals might deteriorate. In that case, fork oil might be allowed to pass through the forks seal, down the stanchion until it reaches the brake discs and calipers. It would then massively reduce the braking capacities of the motorcycle which in turn might cause an accident. It is then important to regularly check the condition of the fork spy seals and therefore the absence of oil on the fork arms.

11.4 Removing and installing the fork arms

Removing the fork arms

- Stop the vehicle (👉 9.5).
- Raise the motorcycle using a bike stool or dirt bike lift stand (👉 12.1).
- Remove the headlight (👉 11.1).
- Remove the front wheel (👉 15.1).
- Remove the forks guards (👉 11.5).
- Remove the front brake caliper / offset bracket assembly by removing the two bolts on the left fork leg with a 5mm Allen key.

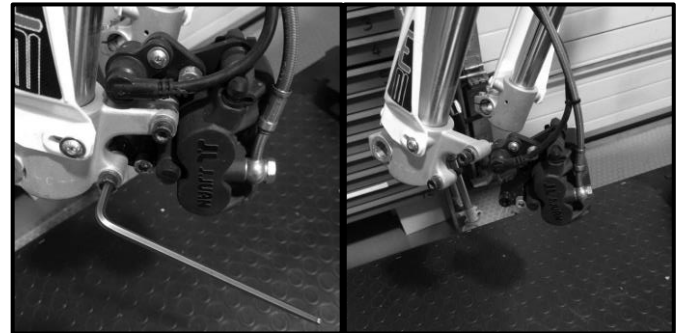

- Let the front brake caliper / offset bracket assembly hang down gently.
- Loosen the upper triple clamp bolts using a 5mm Allen key.



- Loosen the lower triple clamp bolts using a 5mm Allen key.



- Gently pull the fork legs down one by one to remove them.

Installing the forks arms

- Slide the fork legs, one by one, into the triple clamps.
- Align the top surface of the upper triple clamp with the fork leg upper surface.
- First tighten the upper and lower triple clamps bolts without applying too much torque.
- Then, using a torque wrench, tighten the upper and lower triple clamps bolts with a torque of 10 N.m.
- Install the brake caliper/bracket assembly on the left fork. Apply a thread-locking fluid for general purpose on the mounting bolts. Tighten them using a torque wrench with a torque of 11 N.m. and using a 5mm Allen key. Don't forget the washers when inserting the bolts (two washers for the upper bolt, one for the lower one).

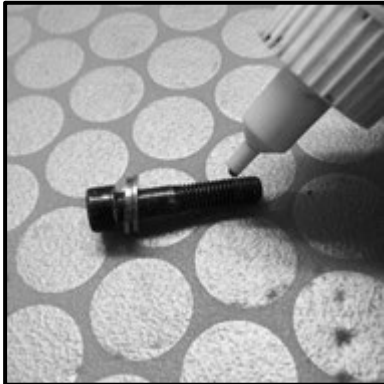

- Reassemble the forks guards (👉 11.5).
- Reassemble the front wheel (👉 15.1).
- Reassemble the headlight (👉 11.1).



Be sure to check that the front brake is working properly before riding again. It might be possible that the brake pads were spread apart to make the reassembling of the front wheel easier. The front brake lever then feels soft and it must be squeezed several times to push the brake pads against the disc. Normal front wheel braking will then be restored.

11.5 Removing and installing the forks protections

Removing the forks protection

- Stop the vehicle (👉 9.5).
- Raise the motorcycle using a bike stool or dirt bike lift stand (👉 12.1).
- Remove the brake hose bracket with an 8mm wrench.



- Remove the fork protection bolts with a 4mm Allen key (unlock the three bolts and then loosen them completely).



Installing the forks protection

Perform all removal actions in reverse order to install the forks protection.

11.6 Removing and installing the front fender

Removing the front fender

- Stop the vehicle (👉 9.5).
- Raise the motorcycle using a bike stool or dirt bike lift stand (👉 12.1).
- Remove the four bolts holding the fender with a 4mm Allen key.



- Remove the front fender.
- Check that the spacers remain in place.

Installing the front fender

Perform all removal actions in reverse order for reassembly.

11.7 Removing and installing the upper triple clamp

Removing the upper triple clamp

- Stop the vehicle (👉 9.5).
- Raise the motorcycle using a bike stool or dirt bike lift stand (👉 12.1).
- Remove the handlebars (👉 11.9).
- Remove the headlight (👉 11.1).
- Loosen the upper triple clamp bolts using a 5mm Allen key.

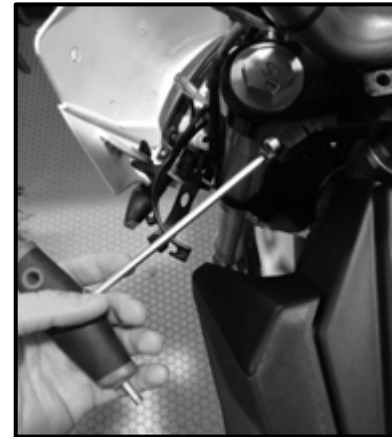

- Loosen and remove the nut holding the steering stem using a 30mm spanner.



- Remove the upper triple clamp by pulling it upwards.



Installing the upper triple clamp

- Install the upper triple clamp into the forks and steering stem.
- Lock the upper triple clamp by tightening the nut on the steering stem using a 30mm spanner and applying a torque of 20 N.m.
- Tighten the upper triple clamp bolts using a torque wrench with a torque of 10 N.m.
- Install the handlebars (👉 11.9).



11.8 Steering Column Maintenance

 It is important to regularly check the bearing operating clearance of the steering column. An improper operating clearance on the steering column results in unstable road behavior and may be very dangerous. It is therefore necessary to check this operating clearance regularly and the condition of the steering column bearing.

On the other hand, to increase the service life of the steering column bearing, it is recommended to carry out their complete cleaning and lubrication occasionally.

Note: When the motorcycle is used for a long period of time while the steering column bearing operating clearance is too large, the bearing and its housing may be damaged.

Checking the operating clearance of the steering head bearing

- Stop the vehicle ( 9.5).
- Raise the motorcycle using a bike stool or dirt bike lift stand so that the front wheel is off the ground ( 12.1).
- Place the handlebars in a straight position. While someone else sits on the bike and hold the handlebars, hold the bottom of the forks and move the fork arms forward and backward in the axis of the motorcycle. Ideally, you shouldn't feel any play coming from the stem bearings.

- If, when you move the handlebars from one side to another, you can feel some resistance, the steering stem bearings might be too tight.

 When there is a play or resistance in the steering stem bearing, adjust the bearing by tightening or untightening them on the steering stem. If, after adjusting the bearing tightness, the problem remains, replace your steering stem bearings.

Adjusting the steering stem bearings operating clearance

- If steering feels hard, slightly loosen the steering stem nut using a universal shock spring spanner.
- If you can feel some play in the bearings, retighten the steering stem nut using a universal shock spring spanner.



11.9 Removing and replacing the handlebars

Removing the handlebars

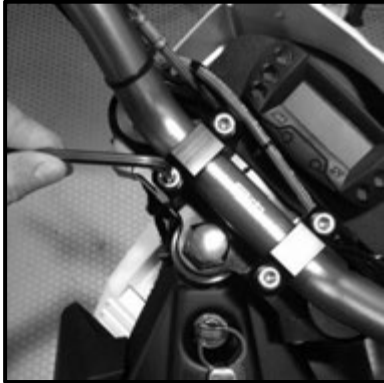

- Stop the vehicle (🔧 9.5).
- Raise the motorcycle using a bike stool or dirt bike lift stand (🔧 12.1).
- Remove the bar mounts screws holding the handlebars on the upper triple clamp using a 6mm Allen key.
- Remove the handlebars.

Installing the handlebars

- Place the handlebars in the lower part of the bar mounts.
- Place the upper part of the bar mounts on the handlebars.
- Install and tighten the bar mounts screws with a torque of 20 N.m using a 6mm Allen key.



Before riding the motorcycle again, make sure that you have correctly secured the handlebars in order to avoid any dangerous accident.

12. Maintenance work on the central part

12.1 Raising the motorcycle on a stand

- Stop the vehicle (👉 9.5).
- Raise the motorcycle using a bike stool or dirt bike lift stand by placing it under the skid plate.



Be sure to place the stand on a flat surface to prevent the motorcycle from falling.

Take care of your back when lifting the bike if you do not have an adjustable lift stand.

Make sure the motorcycle is stable on the stand before releasing it to prevent the vehicle from falling.

12.2 Removing and installing the seat

Removing the seat

- Stop the vehicle (👉 9.5).
- Insert the key in the seat lock and turn it clockwise.



- Extract the seat by, at the same time, raising it and pulling towards the rear of the motorcycle.



Installing the seat

- Place the seat back on the motorcycle, taking care to align the seat hooks with the frame and tank brackets. You should hear a “click” when the seat lock engages with its matching part on the motorcycle. The seat is then locked.

12.3 Maintenance of the motorcycle frame

- Stop the vehicle (👉 9.5).
- Raise the motorcycle using a bike stool or dirt bike lift stand (👉 12.1).
- Remove the motorcycle plastics (👉 12.4).
- Remove the battery pack (👉 16.1).
- Carefully inspect all visible parts of the frame for unusual wear or cracks.
- Install the battery pack (👉 16.1).
- Install the motorcycle plastics (👉 12.4).



In case of unusual mechanical use of the motorcycle (fall or collision), it is important to take care to inspect the frame as thoroughly as possible. In case any cracks or others unusual wear are detected do not take any risk by driving the motorcycle and contact Electric-Motion customer service promptly. Electric-motion disclaims all liability for any repairs done to the frame and therefore prohibits any repairs to the frame.

12.4 Removing and installing the motorcycle plastics

Removing the seat

- Stop the vehicle (👉 9.5).
- Raise the motorcycle using a bike stool or dirt bike lift stand (👉 12.1).
- Remove the headlight (👉 11.1).
- Remove the forks protections (👉 11.5).
- Remove the front fender (👉 11.6).
- Remove the seat (👉 12.2).
- Remove the front side panel with a 3mm Allen key by unscrewing the 3 screws holding it.

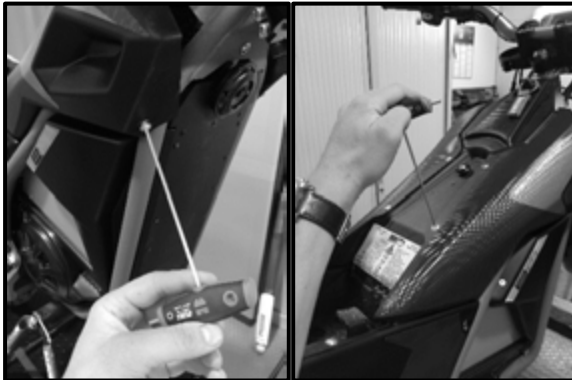

- Remove the rear side panel with a 3mm Allen key by unscrewing the 3 screws holding it.

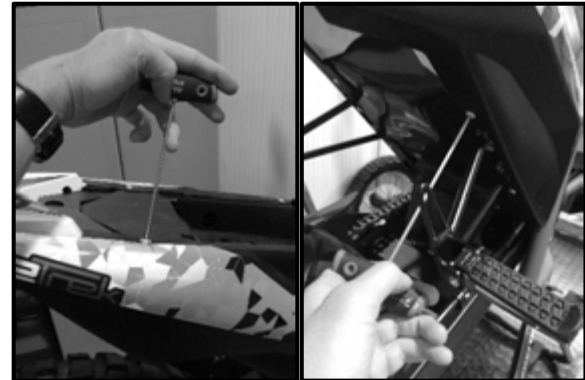

- Remove the rear fender (👉 13.3).

- Remove the screw holding the side plastic covering the battery pack (named Boomerang) with a 3mm Allen key.

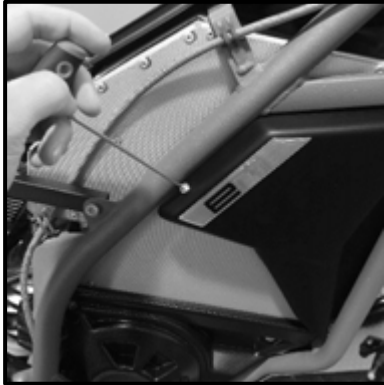

Installing the plastics

Perform all removal actions in reverse order to install the plastics.

13. Maintenance work on the rear of the bike

13.1 Removing and installing the shock absorber

Removing the shock absorber

- Stop the vehicle (🔧 9.5).
- Raise the motorcycle using a bike stool or dirt bike lift stand (🔧 12.1).
- Remove the rear side panel (🔧 12.4).
- Using a 17mm wrench, remove the shock absorber upper mounting bolt and nut.

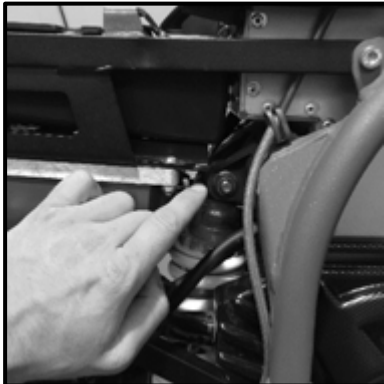

- Using a 17mm wrench, remove the shock absorber lower mounting bolt and nut.



- Gently remove the shock absorber from the frame and swinging arm.

Installing the shock absorber

Perform all removal actions in reverse order to install the shock absorber.



To prevent the bolts and nuts from getting loose, it is important to secure them by applying a thread-locking fluid for general purpose on the bolts thread.

13.2 Swing Arm Maintenance

- Stop the vehicle (👉 9.5).
- Raise the motorcycle using a bike stool or dirt bike lift stand (👉 12.1).
- Remove the rear wheel (👉 15.2).
- Carefully inspect all visible parts of the swing arm for unusual wear or cracks.



In case of unusual mechanical use of the motorcycle (fall or collision), it is important to take care to inspect the swing arm as thoroughly as possible. In case any cracks or others unusual wear are detected do not take any risk by driving the motorcycle and contact Electric-Motion customer service promptly.

Electric-motion disclaims all liability for any repairs done to the frame and therefore prohibits any repairs to the frame.

13.3 Removing and installing the rear fender assembly

Removing the rear fender, the tail light fender and the indicators/number plate fender

- Stop the vehicle (👉 9.5).
- Raise the motorcycle using a bike stool or dirt bike lift stand (👉 12.1).
- Using a 4mm Allen key, unscrew the 6 screws holding the rear mudguard assembly.





- Gently disconnect the rear light connector and cut the cable tie holding it to the subframe using a cutter.

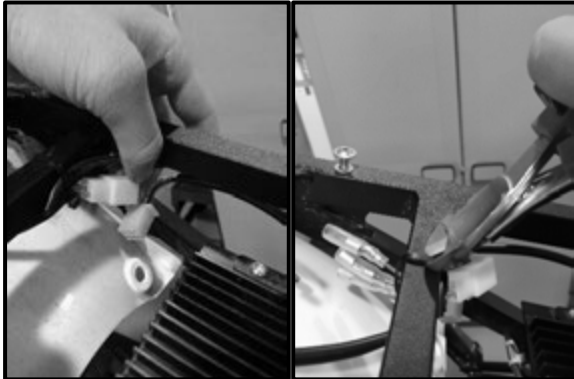

- Remove the rear fender assembly from the motorcycle by pulling it backwards.
- Separate the tail light fender from the rear fender using a Phillips type screwdriver.
- Separate the indicators and number plate fender from the tail light using an 8mm and a 7mm spanner and with a 3mm Allen key.



- Then disconnect the connectors for the rear lights assembly.



Installing the rear fender, the tail light fender and the indicators/number plate fender

Perform all removal actions in reverse to install the rear fender, the tail light fender and the indicator/number plate fender.

13.4 Transmission chain maintenance

Checking for chain dirt and cleaning it

- Stop the vehicle (👉 9.5).
- Raise the motorcycle using a bike stool or dirt bike lift stand (👉 12.1).
- Check the chain for coarse dirt accumulation. If the chain is dirty, clean it using a chain degreaser and a brush.
- Lubricate the chain with a chain lube spray.



Do not spray chain grease on the motorcycle tires or on the brake disc, otherwise the motorcycle's handling and braking performance will be severely reduced. When spraying grease on tires or brake discs, degrease immediately using a degreaser.

Checking the chain tension

- Stop the vehicle (👉 9.5).
- Raise the motorcycle using a bike stool or dirt bike lift stand (👉 12.1).
- Using a ruler, position yourself at the end of the chain slider underneath the swing arm, the distance between the swing arm and the chain must be ranging from 15mm to 50mm.

Lower limit = 15mm:



Upper limit = 50mm:

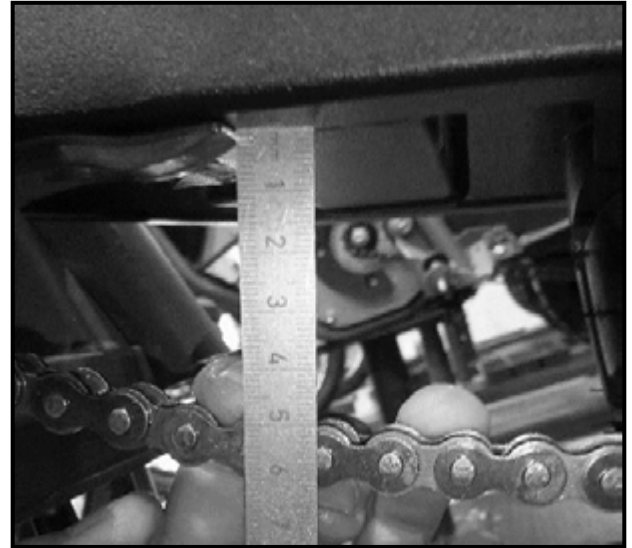

- If the chain tension is out of the specified range, you will need to adjust it.

Adjusting the chain tension

- Loosen the wheel axle nut using two 30mm spanners or two 30mm sockets with wrenches.
- On both sides of the swing arm, loosen the locknuts, then adjust the chain tension by screwing or unscrewing the adjusting bolts with a spanner of 10 (make sure that the chain adjusters on both sides are at the same position relative to the reference marks on the swing arm).

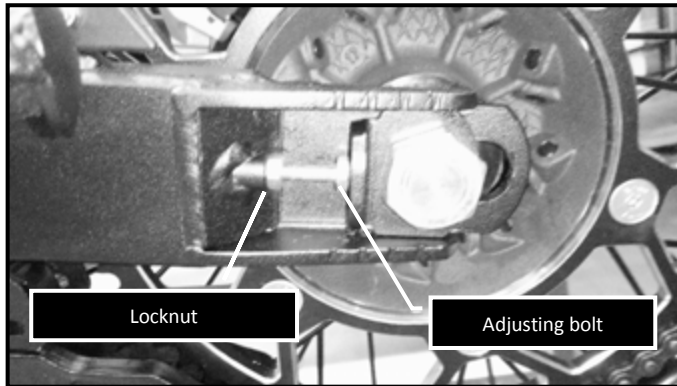

- Loosen the wheel axle nut using two 30mm spanners or two 30mm sockets with wrenches.



There are many risks associated with using a chain that is too tight or not tight enough. If the chain is too tight, in addition to being worn faster than normal, it will damage the front and rear sprockets. On the other hand, if the chain is not tight enough, it can jump off the front or rear sprockets and block the rear wheel or damage the motor. In any case, an incorrect chain tension is synonymous with danger.

Checking for sprocket tooth wear

Before each use of the Etrek, make sure that all the transmissions components are in good condition:

- Stop the vehicle (👉 9.5).
- Raise the motorcycle using a bike stool or dirt bike lift stand (👉 12.1).
- Check for any front and rear sprocket wear.

Example of sprocket tooth in good condition:



Example of sprocket tooth in bad condition (to be replaced):



Checking for chain wear

- Stop the vehicle (👉 9.5).
- Raise the motorcycle using a bike stool or dirt bike lift stand (👉 12.1).
- By grabbing the chain with 2 fingers at the rear sprocket, pull the chain backwards. If it is possible to see half a tooth or more, the chain must be replaced.

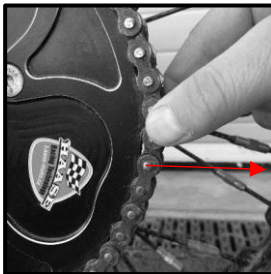

Checking for chain slider wear and its correct position

- Stop the vehicle (👉 9.5).
- Raise the motorcycle using a bike stool or dirt bike lift stand (👉 12.1).
- Inspect the condition of the chain slider and the tightening of the screws holding it.



The motor sprockets and chain must always be replaced at the same time.

Replacing the rear sprocket

- Stop the vehicle (👉 9.5).
- Raise the motorcycle using a bike stool or dirt bike lift stand (👉 12.1).
- Remove the rear wheel (👉 15.2).
- With a 5mm Allen key and a 13mm spanner, remove the sprocket bolts and nuts. Be sure to unlock all bolts before loosening them completely. Use the Allen key to prevent the bolts from rotating and the flat key to loosen the nuts and not the opposite, otherwise the bolts heads will be damaged.
- Proceed in the same way to install the rear sprocket, but first, add thread-locking fluid for general purpose on the bolts thread. Then gently start tightening all the nuts on the bolts before proceeding to tightening them with a torque of 20 N.m.

14. Maintenance work on the brake system

14.1 Checking and replacing the brake discs

Checking the condition of the brake discs

- Stop the vehicle (👉 9.5).
- Raise the motorcycle using a bike stool or dirt bike lift stand (👉 12.1).
- Check the thickness of the brake discs using a caliper. The minimum thickness measured all around the discs must be greater than the minimum acceptable thickness.



- Check the absence of rough patches or unusual wear (cracks) on the brake discs.
- Replace the brake discs if the minimum thickness is not respected or if there is an unusual wear on the discs.

Disc	Front	Rear
Minimum acceptable thickness	3,5mm	3mm



The brakes efficiency is reduced by worn brake discs. If you have any doubt contact Electric-motion customer service.

Replacing brake discs

- Stop the vehicle (👉 9.5).
- Raise the motorcycle using a bike stool or dirt bike lift stand (👉 12.1).
- To replace the front brake disc, remove the front wheel (👉 15.1).
- To replace the rear brake disc, remove the rear wheel (👉 15.2).
- Remove the screws holding the brake disc on the hub using a 4mm Allen key and remove the disc.
- Install the new brake disc, add thread-locking fluid for general purpose on the screws thread.

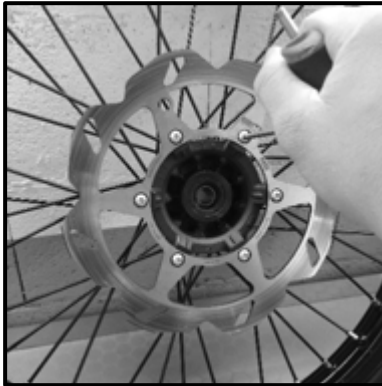

- Install the screws and tighten them with a torque of 12 N.m.

14.2 Checking and adjusting the brake fluid level

- Stop the vehicle (🔧 9.5).
- Raise the motorcycle using a bike stool or dirt bike lift stand (🔧 12.1).
- Make sure that both brake reservoirs on the handlebars are positioned horizontally.

- Check that the liquid level is well above the minimum level
 - o If this is not the case, top up the fluid level (🔧 14.4).
- Check that the brake fluid is not dirty. It should light colored.
 - o If this is not the case, proceed to have a mechanic, approved by *Electric Motion*, bleed the brake system.
- Check that the brake system is working properly before using the motorcycle.



If the brake fluid level drops below the specified marking, this is an indication that the brake system is leaking or that the brake pads are completely worn down. The brake system must then be inspected and repaired before the vehicle is used again.



Do not run with worn brake fluid. It significantly reduces the motorcycle's braking performance. Bleed the brake system if that is the case.



Use only DOT 4 brake fluid for the brake system. Do not try to use any other liquid. In case of doubt consult Electric-Motion customer service.

14.3 Checking and replacing brake pads

Checking the brake pads

- Stop the vehicle (👉 9.5).
- Raise the motorcycle using a bike stool or dirt bike lift stand (👉 12.1).
- Remove the brake pads (see instructions below).
- Check the thickness of the brake pads using a caliper. The minimum thickness measured must be greater than the minimum acceptable thickness.

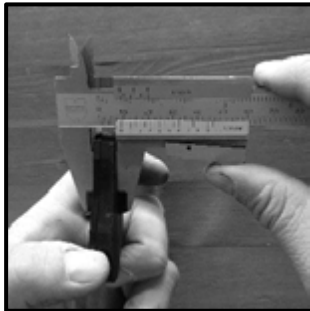

Brake pads	Front	Rear
Minimal distance	2mm	2mm

Removing front brake pads

- Stop the vehicle (👉 9.5).
- Raise the motorcycle using a bike stool or dirt bike lift stand (👉 12.1).
- Remove the front wheel (👉 15.1) if necessary to have more space to work.
- Using a slotted screwdriver, disassemble the 2 snap rings holding the pads pins.



- Remove the 2 pads pins using a small size Allen key.



- Remove the brake pads.

Installing front brake pads

Perform all removal actions in reverse order to install front brake pads.

Use pliers to install the snap rings holding the brake pads.



Removing rear brake pads

- Stop the vehicle (👉 9.5).
- Raise the motorcycle using a bike stool or dirt bike lift stand (👉 12.1).
- Remove the rear wheel (👉 15.2) if necessary to have more space to work.
- Using a 5mm Allen key, unscrew the pin holding the brake pads.

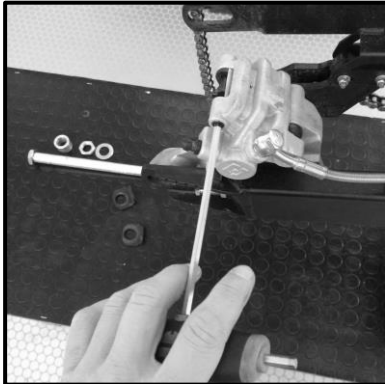

- Remove the brake pad pin.

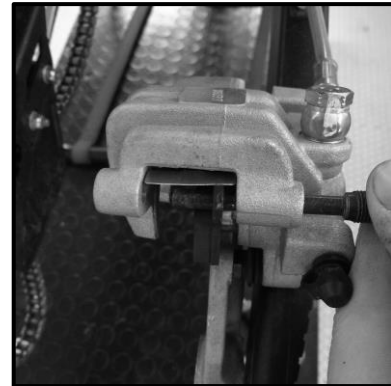

- Remove the brake pads by grabbing them from the side of the caliper facing the rear of the motorcycle.

Installing rear brake pads

Perform all removal actions in reverse order to install rear brake pads.

Make sure that the brake pads are inserted into the brake caliper notch as it can be seen in the picture below.

Tightening torque of the rear brake pad pin: 10 N.m.

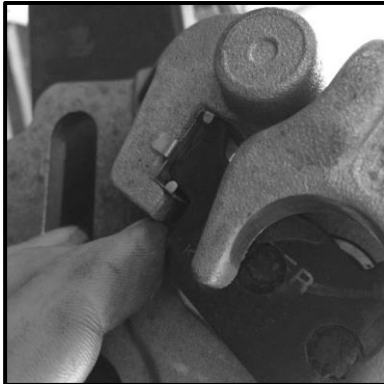

 Replacement of the brake pads must be carried out correctly, otherwise the motorcycle user will be endangered.
Be sure to protect yourself against brake fluids by wearing glasses and protective clothing.

14.4 Adding brake fluid to the reservoirs

- Stop the vehicle (🔗 9.5).
- Raise the motorcycle using a bike stool or dirt bike lift stand (🔗 12.1).
- Open the brake fluid reservoir lids on the right and left of the handlebars (brake fluid reservoir in a horizontal position).

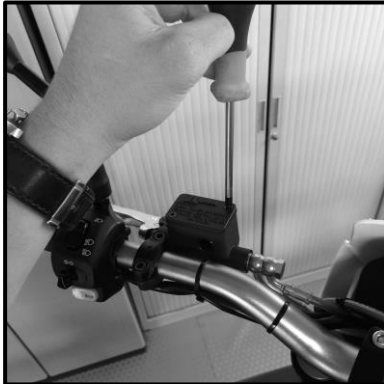

- Remove the reservoir diaphragms.



- Top-up the reservoirs with DOT 4 brake fluid so that the brake fluid level is at least above the “MIN” marking on the reservoirs.



- Install the reservoirs diaphragms and then the lids.
- Install the screws and tighten them.

- Check the brake liquid level (brake fluid reservoir in a horizontal position).



 Only use DOT 4 brake fluid. Any other fluid will cause severe damages to the brake system. In case of doubt consult Electric-Motion customer service.

 Be careful not to spray brake fluid on the discs, otherwise braking will be ineffective. If necessary degrease the disc using a degreaser.

15. Maintenance work on the wheels

15.1 Removing and installing the front wheel

- Stop the vehicle (🔧 9.5).
- Raise the motorcycle using a bike stool or dirt bike lift stand (🔧 12.1).

Removing the front wheel

- Loosen the wheel spindle nut a few turns using a spanner of 24.



- Loosen the secondary screws with a 5mm Allen key.



- Push the wheel spindle nut towards the wheel hub in order to push the wheel spindle out of the forks (if necessary use a rubber mallet).



- Hold the front wheel and remove the wheel spindle (use pliers if necessary).



- Remove the spindle nut.

- Remove the front wheel of the fork by moving it towards the front of the motorcycle.



 Do not operate the brake system levers when the wheel has been removed, otherwise the brake pads will be pushed by the caliper pistons. You won't have enough space between the pads to insert the disc when installing the wheel. If necessary, push the pads back with a flat screwdriver.

Installing the front wheel

- Check the condition of the front wheel spindle. If it is in poor condition (cracks), replace it immediately. If necessary, clean the wheel spindle with a wire brush.



- Clean and grease the front wheel spindle, the front wheel spacers and the seal rings.

- Position the front wheel and insert the wheel spindle through the forks. Do not forget to install the spacer between the hub and the fork on the disc side of the wheel.



- Add thread-locking fluid for general purpose on the spindle thread.

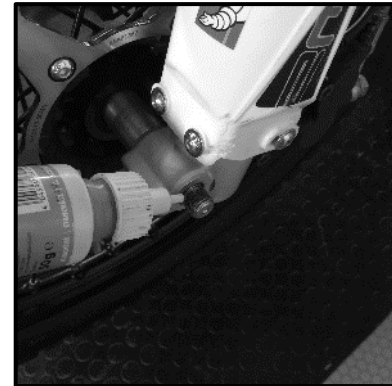

- Install the nut on the spindle and tighten it with a torque of 20 N.m using a socket of 24mm and a torque wrench.



- Tighten the secondary screws to a torque of 10 N.m using a 5mm Allen key.



- Squeeze the front brake lever several times so that the brake pads are pushed against the disc and that the wheel is centered.
- Remove the motorcycle from the bike stool or from the dirt bike lift stand.
- Operate the front brake and compress the fork several times in order to correctly position the fork.

 Before using the motorcycle, be sure to squeeze the front brake lever to position the brake pads against the disc and regain normal braking. Do not go back on the road with non-operational brakes.

15.2 Removing and installing the rear wheel

- Stop the vehicle (🔧 9.5).
- Raise the motorcycle using a bike stool or dirt bike lift stand (🔧 12.1).

Removing the rear wheel

- Loosen the spindle nut a few turns using a 30mm spanner.



- Push the wheel spindle nut towards the wheel hub in order to push the wheel spindle out of the swing arm (use a rubber mallet if necessary).



- Remove the spindle nut.
- Hold the rear wheel and remove the wheel spindle, use pliers if necessary.

- Push the rear wheel as far forward as possible to remove the chain from the rear sprocket.



- Remove the rear wheel from the swing arm.

 Do not operate the brake system levers when the wheel has been removed, otherwise the brake pads will be pushed by the caliper pistons. You won't have enough space between the pads to insert the disc when installing the wheel. If necessary, push the pads back with a flat screwdriver.

Installing the rear wheel

- Check the condition of the rear wheel spindle. If it is in poor condition (cracks), replace it immediately. If necessary, clean the wheel spindle with a wire brush.
- Clean and lubricate the rear wheel axle, spacers and the seal rings.
- Position the rear wheel so that you can install the chain on the rear sprocket.
- Insert the wheel spindle from the sprocket side of the motorcycle, don't forget to position the spacers between the wheel hub and the swing arm.
- Add thread-locking fluid for general purpose on the spindle thread.
- Install the nut on the spindle and tighten it with a torque of 60 N.m using a spanner of 30mm.
- Squeeze the rear brake lever several times so that the brake pads are pushed against the disc.

 Before using the motorcycle, be sure to squeeze the rear brake lever to position the brake pads against the disc and regain normal braking. Do not go back on the road with non-operational brakes.

15.3 Checking tire condition

- Stop the vehicle (🔧 9.5).
- Raise the motorcycle using a bike stool or dirt bike lift stand (🔧 12.1).
- Check that there is no sharp object stuck in the tire.
- Check that there is no bumps or bulges within the tire body.
- Check that the depth of the tire tread is not below the minimum permissible depth.

If one tire are found to have any of the above conditions, replace the tire before returning to the road.



Only use tires of good quality, recommended by Electric-motion. The type, condition and air pressure of the tires all have a major impact on the handling characteristics of the motorcycle.

On wet roads, it is dangerous to use worn tires.

The front and rear wheels should only be equipped with tires of the same profile.

Electric-motion recommends a change of tire every 5 years, regardless of their state of wear.

15.4 Checking tire air pressure

- Stop the vehicle (🔧 9.5).
- Raise the motorcycle using a bike stool or dirt bike lift stand (🔧 12.1).
- Remove the valve cap on the wheel.
- Check the air pressure when the tire is cold and in agreement with the pressure table below.

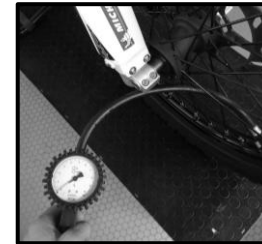

- Rectify the tire air pressure if necessary.
- Replace the valve cap.

	Front pressure	Rear pressure
Road use	2,0 Bars	2,0 Bars
Trail riding	1,5 Bars	1,5 Bars



Regularly check tire pressure. Driving over-inflated or under-inflated is dangerous and greatly increases the risk of loss of vehicle control.

15.5 Checking spokes tension

- Stop the vehicle (🔧 9.5).
- Raise the motorcycle using a bike stool or dirt bike lift stand (🔧 12.1).
- Check the tightening of each spoke on both wheels with the help of a torque wrench (tightening torque should be 5N.m).



In the presence of loose spokes, the behavior of the motorcycle is unstable. Regularly check the tension of the spokes. Do not overtight the spokes to avoid breaking them.

16. Maintenance work on electrical components

16.1 Removing and installing the battery pack

Removing the battery pack

- Stop the vehicle (🔧 9.5).
- Raise the motorcycle using a bike stool or dirt bike lift stand (🔧 12.1).
- Make sure that the ignition key is in the "OFF" position and remove the ignition key from the ignition lock.
- Remove the front wheel (🔧 15.1).
- Remove the rear side (🔧 12.4).

- Check with a voltmeter at the controller's battery terminals, the battery voltage is 0V (maximum voltage 58.8 V approximately).



- Unscrew the negative terminal (black color) from the battery connected to the controller with a 10 mm spanner.

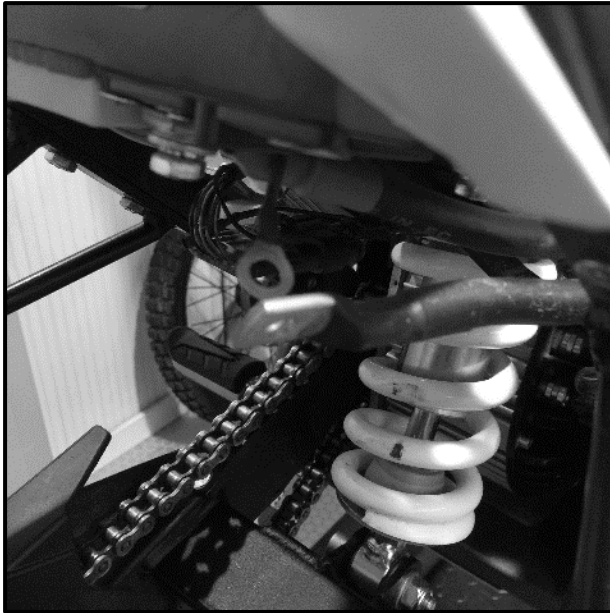

- Insulate the negative terminal at the end of the battery cables by wrapping it with insulating tape. It will avoid any risks of damaging the vehicle or getting hurt.



- Do the same with the positive terminal (red color).

- Remove the side plastic covering the battery pack (named Boomerang) (🔧 12.4).

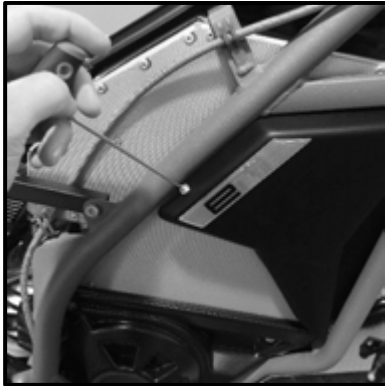

- Remove the right motor housing by removing the 2 screws using a 4mm Allen key.



- With a 10mm flat spanner, remove the lower screw holding the battery.



- Using a 4mm Allen key, remove the 2 screw holding the battery located at the front of the motorcycle.

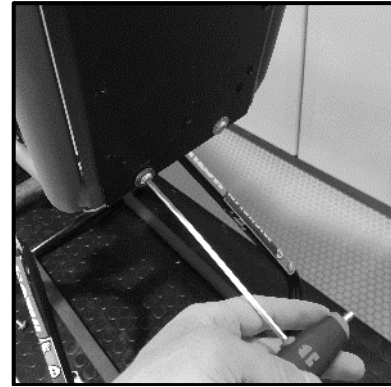

- Using a 3mm Allen key, remove the horn located under the lower triple clamp.

- Slightly slide the battery towards the forks to gain access to the connector connecting the battery to the motorcycle harness. Disconnect the harness plug from the battery.



- Then take out the battery by tilting it as it exits the frame.

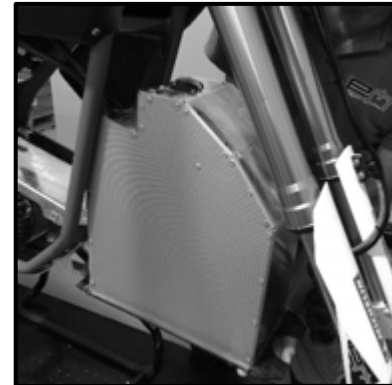
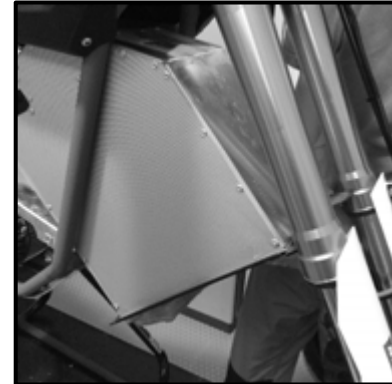

Installing the battery pack

Perform all removal actions in reverse order to install the battery pack.



It is important to connect the battery positive terminal before the negative terminal on the controller when reassembling the battery pack on the motorcycle.

Be careful to avoid any contact between the battery terminals themselves or between one terminal and one part of the motorcycle, otherwise the electrical components of the motorcycle will be irretrievably damaged.

16.2 Replacing the front light bulb

- Stop the vehicle (👉 9.5).
- Raise the motorcycle using a bike stool or dirt bike lift stand (👉 12.1).
- Remove the headlight (👉 11.1).
- Remove the rubber seal cap on the inside of the headlight.

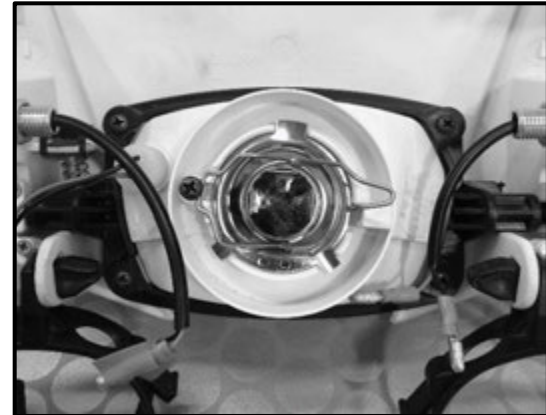

- Press and release the mounting spring that holds the bulb.



- Remove the bulb.



- Install a new bulb by proceeding in reverse order.

16.3 Replacing the tail light

- Stop the vehicle (👉 9.5).
- Raise the motorcycle using a bike stool or dirt bike lift stand (👉 12.1).
- Remove the tail light fender and the number plate/indicators fender (👉 13.3).
- Using an 8mm socket and a wrench remove the 2 nuts holding the tail light.
- Remove the tail light and install a new one by proceeding in reverse order.

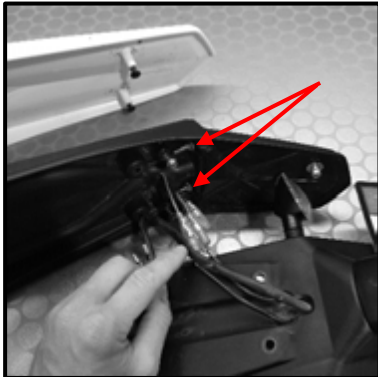

16.4 Replacing the front and rear turn signals

Replacing the front turn signals

- Stop the vehicle (👉 9.5).
- Raise the motorcycle using a bike stool or dirt bike lift stand (👉 12.1).
- Remove the headlight (👉 11.1).
- Remove the nuts holding the front turn signals using a 13mm spanner.
- Remove the front turn signals and install new ones by proceeding in reverse order.

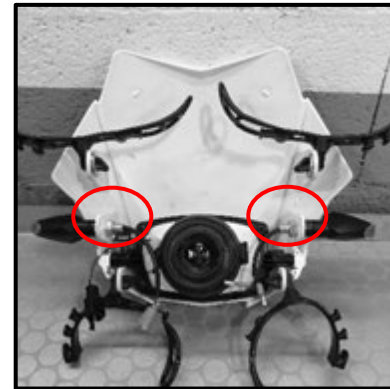

Replacing the rear turn signals

- Stop the vehicle (👉 9.5).
- Raise the motorcycle using a bike stool or dirt bike lift stand (👉 12.1).
- Remove the tail light fender and the number plate/indicators fender (👉 13.3).
- Disconnect the turn signals from the motorcycle harness.



- Remove the nuts holding the rear turn signals using a 13mm spanner.

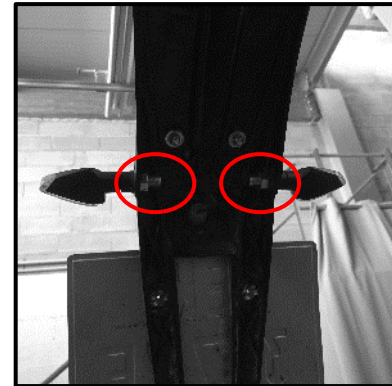

16.5 Replacing fuses

Replacing the converter fuses

- Stop the vehicle (🔧 9.5).
- Raise the motorcycle using a bike stool or dirt bike lift stand (🔧 12.1).
- Remove the rear fender assembly (🔧 13.3).
- Remove the rear side cover (motorcycle plastics) (🔧 12.4).
- After removing the rear fender, the shock absorber protection/guard plastic becomes accessible. Remove it to access the fuses.



1	Converter fuse	5A cartridge fuse
2	Harness fuse 10A	10A blade fuse

- Open the fuse holder and remove the fuse.

Harness fuse and its holder opened



Converter fuse and its holder opened



- Replace the fuse by a new one of equal current and voltage rating.
- Proceed to reassemble the motorcycle different components by proceeding in reverse.

Replacing the main fuse

- Stop the vehicle (👉 9.5).
- Raise the motorcycle using a bike stool or dirt bike lift stand (👉 12.1).
- Remove the rear fender assembly (👉 13.3).
- Remove the rear side cover (motorcycle plastics) (👉 12.4).
- After removing the rear fender, the shock absorber protection/guard plastic becomes accessible. Remove it to access the controller fuse.

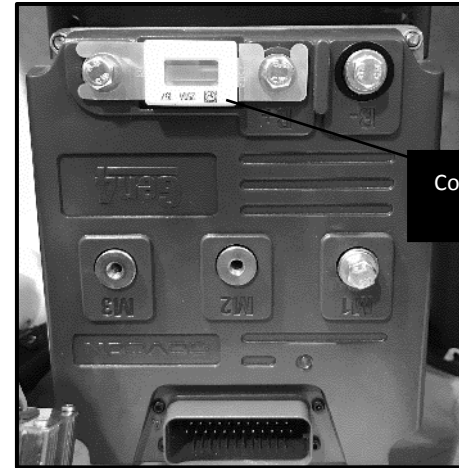

Controller fuse

- Untighten the two screws holding the fuse using a 10mm spanner until you can remove the fuse.
- Replace the fuse by a new one of equal current and voltage rating (250A, 48V fuse strip with housing).
- Proceed to reassemble the motorcycle different components by proceeding in reverse.

16.6 Adjusting the speedometer

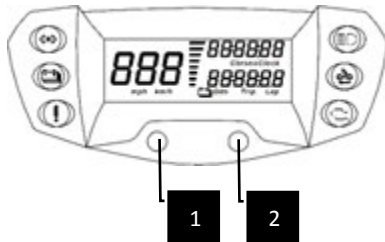

1	Display selection button
2	Counter Reset Button

Button 1 is used to select the speedometer display. Different choices are possible: ODO (total mileage since the first start of the motorcycle), TRIP 1 (mileage since the last reset of TRIP 1), TRIP 2 (mileage since the last reset of TRIP 2).

To reset each trip, display the trip and then hold button 2 until the trip is reset.

17. Troubleshooting

17.1 Electric Motorcycle Precautions

Electric motorcycles produced by *Electric-Motion* are equipped with electrical components that could present a risk of personal injuries if they are not handled properly. These personal injuries includes severe burns, electric shock or even fatal injuries.

It is imperative not to touch dangerous components to avoid accidents, so do not try to remove them, replace them or even repair them.

If the Etrek motorcycle is involved in an accident, be careful not to come into contact with any electrical component or any damaged cable.

For your safety, always follow the instructions on the labels attached to the vehicle components.

If a motorcycle fire occurs, extinguish visible flames with a Class D power-type fire extinguisher. Then, after the flames have been extinguish, douse the motorcycle with a water-based fire extinguisher.

As a general rule, do not take any risk when handling your motorcycle. Contact Electric-Motion customer service in case of problem.

17.2 Caution regarding *Electric-motion* motorcycles

Before delivery, all our motorcycles are thoroughly inspected. However, even after this inspection, there may be technical problems that may prevent the motorcycle from functioning properly. The information contained in the chapters dedicated to the motorcycle maintenance by its owner can make it possible to locate the origin of a breakdown and to correct it without the help of Electric-motion. However, if in doubt, do not risk damaging your vehicle and contact *Electric-motion* customer service.

17.3 Fault diagnosis dashboard indicator

If a fault has been detected by the motorcycle electronics, the lower right LED flashes on the dashboard. Depending on the number of flashes repeated during a flashing cycle, it is possible to determine the cause of the problem and to remedy it.

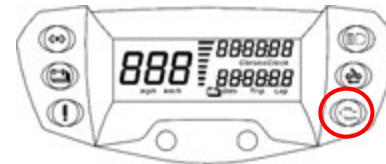

However, if there is any doubt about what to do in the event of a flashing signal, contact *Electric Motion* customer service.

Number of flashes	Message	Recommended actions
2	Emergency Stop Switch to "OFF"	Position Emergency Stop Switch to "ON".
5	Engine response fault	Have the motorcycle checked by an <i>Electric Motion</i> dealer.
6	Kickstand safety fault	Check that the kickstand is correctly folded.
7	Battery fault	Charge the battery.
8	Motor-battery temperature fault	Set the motorcycle in a good temperature environment.
10	Controller fault	Have the motorcycle checked by an <i>Electric Motion</i> dealer.
11	Encoder fault	Have the motorcycle checked by an <i>Electric Motion</i> dealer.
12	CAN language fault	Have the motorcycle checked by an <i>Electric Motion</i> dealer.
15	Vehicle maintenance required	Have the motorcycle checked by an <i>Electric Motion</i> dealer.

17.4 Tightening torque summary table

Item	Tightening torque (N.m)
Upper triple clamp screws	10
Lower triple clamp screws	10
Steering column stem nut	20
Front brake caliper / offset bracket screws	20
Front brake caliper offset bracket / fork	11
Rear sprocket bolts and nuts	20
Front brake disc screws	10
Rear brake disc screws	10
Front wheel spindle nut	20
Rear wheel axle nut	60
Front wheel spindle secondary screws	10
Master cylinder screws	10
Handlebars bar mounts screws	20
Brake pad pin for the rear brake caliper	10

17.5 Maintenance schedule

Maintenance to be carried out	Periodicity
Front and rear wheel control (tire condition and air pressure).	Before every ride.
Checking that all fasteners are properly tighten.	Every 1000 km (600 miles).
Checking brake condition (brake pads, discs, brake fluid level).	Before every ride.
Bleeding the brake fluid.	Every year.
Replacing the brake pads.	As soon as necessary.
Greasing the transmission chain.	Every 400 km (250 miles).
Checking the transmission chain tension.	Every 1000 km.
Checking the battery charge level and charging.	After every ride.